

Design and Simulation of a Novel Pneumotronic System Aimed to the Investigation of Vascular Phenomena Induced by Limb Compression

Original

Design and Simulation of a Novel Pneumotronic System Aimed to the Investigation of Vascular Phenomena Induced by Limb Compression / Ferraresi, C., De Benedictis, C., Maffiodo, D., Franco, W., Messere, A., Pertusio, R., Roatta, S.. - In: JOURNAL OF BIONIC ENGINEERING. - ISSN 1672-6529. - ELETTRONICO. - 16:3(2019), pp. 550-562.
[10.1007/s42235-019-0045-0]

Availability:

This version is available at: 11583/2735533 since: 2023-10-13T10:32:21Z

Publisher:

Springer

Published

DOI:10.1007/s42235-019-0045-0

Terms of use:

This article is made available under terms and conditions as specified in the corresponding bibliographic description in the repository

Publisher copyright

Springer postprint/Author's Accepted Manuscript

This version of the article has been accepted for publication, after peer review (when applicable) and is subject to Springer Nature's AM terms of use, but is not the Version of Record and does not reflect post-acceptance improvements, or any corrections. The Version of Record is available online at: <http://dx.doi.org/10.1007/s42235-019-0045-0>

(Article begins on next page)

Design and simulation of a novel pneumo-tronic system aimed to the investigation of vascular phenomena induced by limb compression

Carlo Ferraresi¹, Carlo De Benedictis^{1*}, Daniela Maffiodo¹, Walter Franco¹, Alessandro Messere², Raffaele Pertusio², Silvestro Roatta²

1. *Department of Mechanical and Aerospace Engineering, Politecnico di Torino, Italy*

2. *Department of Neuroscience, University of Torino, Italy*

Abstract

Intermittent Pneumatic Compression (IPC) devices can be used to analyze the mechanisms underlying several vascular phenomena, such as hyperaemia. Commercial devices have limited dynamics and do not allow the delivery of customizable compressive pressure patterns, making difficult the analysis of such phenomena, which may require the application of long stimulations with low amplitude as well as fast compressions with higher pressure level. To overcome these issues, a novel pneumo-tronic device aimed to the investigation of the physiological effects induced by limb compressions has been conceived and is presented in this work. The design requirements of the system, capable of delivering customizable compressive patterns in the range 0-200 mmHg, are outlined. The final prototype architecture is described, and a mathematical model of the entire system, also including the interaction between the device and the limb tissues, is proposed. The performance of the device has been evaluated in several conditions by means of simulations, whose results have been compared to the data collected from experimental trials in order to validate the model. The outcomes of both experimentation and simulation trials proved the effectiveness of the solution proposed. A possible employment of this device for the investigation of the rapid compression-induced hyperaemia is presented. Other potential applications concern the wide range of intermittent-pneumatic compression treatments.

Keywords: pneumo-tronic system, pneutronics, hyperaemia, limb compression, pneumatic system modeling, human-machine interaction

Copyright © 2018, Jilin University.

1 Introduction

Intermittent pneumatic compression (IPC) is a technique based on the application of mechanical stimulations exerted by one or more cuffs wrapped around a limb and has demonstrated its effectiveness

*Corresponding author:

Carlo De Benedictis

E-mail: carlo.debenedictis@polito.it

A preliminary version of the paper has been presented at MESROB2018 IFToMM International Workshop on New Trends in Medical and Service Robotics held in Casino, Italy, 4-6 July 2018

for several rehabilitative applications since the sixties, when a first significant commercial device based on real physiological evidence was released [1, 2]. The cases in which the use of IPC devices is prescribed can range from lymphoedema treatment [3] to management of venous leg ulcers (VLU) [4, 5], from deep vein thrombosis prevention [6] to sports recovery [7, 8].

While venous hydrodynamics during IPC treatment has been already investigated in the past [9], it is only in more recent times that the possible systemic effects of such system, e.g. on arterial blood pressure and cardiac output, were also considered [10]. In particular, these studies have turned to immobilized patients, who have no possibility of using the "muscle pump" mechanism in the lower limbs and in which diseases of the cardiovascular system often arise. In these cases, IPC devices can represent a good substitute for this natural mechanism, providing the required pump functionality necessary for the correct blood circulation.

In addition to the therapeutic implications, these systems can also provide a useful tool to improve the understanding of the physical phenomena underlying the multiple effects of this complex treatment. In fact, ten years ago, the study of Lurie et al. [11] highlighted the incomplete understanding of the phenomenon and proposed an attempt to investigate the changes in venous blood flow due to IPC devices with different characteristics, considering the deformation of limb tissues produced by this pressure. In recent years, several studies presented an active biomechanical device that imitates the muscular pump function on the veins of the lower limbs by exerting coordinated pressure stimulations starting from the foot along the leg [12, 13]. The effectiveness of such device in therapeutic treatments is reported in [14], where it is shown that the intermittent compression improves the diastolic function. In these works, it was necessary to understand the dynamic behavior of an IPC device in response to the control command, both in building a mathematical model and experimentally characterizing elements of the system and soft tissues involved. The mathematical model comprises the whole "human-machine system", describing both the IPC device itself and its interaction with the limb. The accuracy of the

model strongly depends on the parameters used to describe its components, but there is still a lack of knowledge of the parameters with which such therapy must be applied to effectively improve the functionality of the cardiocirculatory system. A method for the experimental characterization of the transversal muscular stiffness and the cuff wall stiffness is proposed in [15], and a reduced-order model-based study is presented in [16].

In recent years a renewed interest was addressed to the understanding of the physiological mechanisms behind the rapid hyperaemia that develops in response to a compressive stimulus and to the ensuing changes in tissue oxygenation [17-20], which can be considered as one of the mechanisms behind the rapid hyperaemia occurring during IPC treatments [10]. While it can be excluded that metabolic dilatory mechanisms may play a role in this response, given the very short duration of the ischemia produced by the compression, the implication of several other mechanisms has been hypothesized and is still discussed in the literature [21]. Among these are the myogenic response, producing a dilatation in response to a compression-induced reduction in vascular transmural pressure, the “muscle pump” which increases the perfusion pressure upon compression-induced emptying of venous compartments, the flow mediated-dilatation possibly resulting from endothelium released nitric oxide upon compression-induced increase in shear stress on the vessel wall and other mechano-dependent mechanisms [19, 21, 22]. In this respect a device capable of applying customizable compressive patterns to the limbs of the patients with high dynamics and accuracy could help in testing different hypotheses. For instance, the possibility to add pre- and post- compression levels to the pressure patterns could be used to modulate vascular filling and the vessel’s transmural pressure. Commercial IPC devices are not currently able to apply fully customizable compressive stimuli, and have limited dynamics, as they do not achieve a good compromise between accuracy in static conditions and fast dynamic response. A novel device should be able to define long-lasting stimulations at low pressure level, as well as fast compressive stimuli with high amplitude.

To overcome the limits of commercial devices, a novel pneumo-tronic device based on the application of defined pressure patterns to the limb of a subject with high dynamic performance, so as to allow the investigation of vascular phenomena with appropriate accuracy and precision, has been designed and is presented in this paper. A general description of the device architecture has been already presented in [23], in which the Authors focused on a clinical application concerning the study of vascular reactivity to an external compression exerted by a pressure-controlled pneumatic cuff. A preliminary characterization of the system has been presented in [24], considering only a limited working condition (step pressure reference signal, 50 mmHg of amplitude). In the present work, a more general approach to the modelling of the inflatable cuff is presented, and more emphasis is given to the discussion of the viscoelastic parameters included in the model.

Section 2 describes the methodology of the work, consisting in the outline of design features and dynamic requirements of the system, the architecture of the final prototype, and the analytical model of the system, including an accurate method for the identification of viscoelastic parameters. Simulations of the model, supported by comparison with outcomes of experimental trials, allowed the optimization and tuning of the model itself and the evaluation of the system behavior in different operating conditions. Section 3 reports the results of the simulations, as well as the outcomes of the first in-vivo trials performed with the system, focused on the investigation of the main factors in the compression-induced hyperaemia. The results of simulations and experimental tests are discussed in section 4.

2 Methods

2.1 Search of the most appropriate architecture of the pneumo-tronic system

The main feature of this device is the need to combine high accuracy and precision (≤ 10 mmHg) under static conditions in the field of physiological pressures, and high dynamic performance (response time ≤ 0.3 s).

The use of a pressure proportional valve with a range similar to the required physiological range would be recommended to minimize the static error, but this would necessarily mean a maximum flow rate insufficient to guarantee good dynamics of the device.

On the other hand, larger proportional pressure valves, which are therefore able to guarantee the required flow rate, do not have adequate accuracy and generally have a minimum regulated pressure value greater than a given threshold. For example, the pressure proportional valve SMC ITV1010 would provide the required flow rate (200 dm³/min ANR), but it has an inadequate adjustment range, being unable to regulate the pressure below 0.005 MPa (37.5 mmHg).

In order to find the optimal solution of the pneumatic circuit, three different configurations have been preliminary tested. A commercial cuff for blood pressure measurement (about 14.5 cm x 30.5 cm x 0.1 cm at rest, about 1 dm³ of volume when inflated) was selected and used for all of the preliminary trials, as well as for the final prototype. A pressure step (50 mmHg of amplitude, lasting 50 s) was considered as a reference input to evaluate the effectiveness of three different solutions for the pneumatic control circuit:

- two digital valves DV1 and DV2 (direct operated solenoid normally closed valves, two ports two positions 2/2 SMC VXE2330-02F-6D01) respectively connected to the inlet and outlet of the cuff;
- a compact pressure proportional valve PPV (SMC ITV0010-2S) connected to the cuff;
- the combination of the pressure proportional valve PPV and the two digital valves DV1 and DV2, the first one used to inflate and the second one to deflate the cuff.

The pressure proportional valve has a regulating range from 0.001 to 0.1 MPa (7.5-750 mmHg), good static characteristics (linearity $\leq 1\%$ full scale F.S.; hysteresis $\leq 0.5\%$ F.S; repeatability $\leq 0.5\%$ F.S), and proper dynamic characteristics (response time 0.1 s). Its maximum flow rate is 6 dm³/min (Standard Reference Atmosphere ANR). The cuff internal pressure control loop is performed by comparison of

the desired reference signal with the output of a pressure transducer PT (BP-1, WPI, Sarasota USA), sampled at 100 Hz by a data acquisition system (CED Micro 1041, Cambridge Electronic Design, UK) and logged to a personal computer. Figure 1 shows the results of the preliminary test: while the cuff pressure could not be kept at the required value using only the digital valves, the single PPV solution managed to reach and hold the desired value with sufficient accuracy, hence providing a slow transient response. As expected, the PPV, due to its compact size, is not suited to quickly inflate and deflate the cuff, mainly because of its limited flow rate. The third solution, based on the combination of digital valves and the pressure proportional valve, resulted to be the most efficient and feasible for the application, providing fast transients during charging and discharging of the cuff, nonetheless highlighting an accurate control of the required set pressure.

2.2 The final architecture of the device

The pneumatic circuit depicted in Fig. 2 has been designed, based on the commercial components used for the preliminary tests. The 2/2 digital solenoid valve DV1 is used to reduce the inflate response time of the device, supplied at 1.3 bar of relative pressure by means of a pressure regulator. A second 2/2 digital solenoid valve DV2 (identical to the first one) drives the discharging of the cuff, providing a significant enhancement of the flow rate with respect to the PPV only solution. While the digital valves operate only during the fast-transient phases (inflate-deflate), the compact pressure proportional valve PPV, designed to perform an accurate control at relatively low levels of pressure, is functioning during the entire active condition, consisting of the inflating of the cuff and the regulation of the internal pressure on constant levels, depending on the specific trial. The PPV is supplied at 1.8 bar and it is directly driven by the control system, which also manages the activation and switch-off of the digital solenoid valves. The same transducer PT and data acquisition system presented in the previous section were used in the final system architecture.

The control logic has been implemented as a routine for the Spike2 software, which is also used to provide an interface to the operator for the definition of the control parameters and to be employed as a signal viewer and analyzer. The control system provides the actual voltage command u_{PPV} (0-5 V) to the pressure proportional valve depending on the difference between the actual pressure value p_I measured by the transducer and the reference value p_{ref} . In this process, the pressure error signal is processed by means of a Proportional-Integral-Derivative logic, yielding to the calculation of the PPV voltage command. Meanwhile, the control system activates the DV1 during cuff inflation (command signal u_{DV1}), switching off the valve as soon as the desired pressure level is reached, and activates the DV2 when the cuff pressure is required to drop (command signal u_{DV2}). The duration of the inflating and deflating phases, as well as the amplitude of the reference signal, depends on the requirements of the clinical application and of the vascular phenomena to be investigated. A picture of the experimental system is presented in Fig. 3.

2.3 The analytical model of the pneumo-tronic system

The definition of an analytical model of the device provided an effective tool for further analyses of the system, e.g. to evaluate the performance of such architecture for different choices of the system components. The physical device mainly consists of the deformable cuff, which is wrapped around a subject's limb, and of the valves performing the control of the inner pressure.

The presence of air loss in the pneumatic circuit has not been included in the mathematical model, since it is not possible to identify its contribution accurately. Moreover, as stated in section 2.1, the use of the selected PPV allows the system to control the required pressure level with accuracy, therefore the insertion of moderate air losses in the model would only produce an increase in the activity of the proportional valve in terms of the amplitude and of the frequency of the command signal, which is not really one of the main focuses of this study. The default parameters of the system are collected in Table 1.

2.3.1 Model of the cuff

In first approximation, the cuff can be modeled as a chamber with variable volume, whose internal pressure p_I is directly measured by the transducer and fed back to the control system. As the variation of the inner pressure depends on the mechanical characteristic of the cuff combined with the viscoelastic behavior of the soft biological tissues, the following relation between the internal relative pressure p_I and the corresponding chamber volume V_I has been proposed:

$$p_I = k(V_I - V_{i1})^n + \beta \frac{dV_I}{dt} \quad (1)$$

In Eq. (1), the resultant relative pressure is given by the sum of an elastic polynomial term, depending on the parameters k , n (a stiffness coefficient and the degree of the polynomial function) and V_{i1} (the initial volume), and of a viscous term depending on the first derivative of the volume and proportional to the coefficient β .

Considering the first term, as a preliminary approach n could be set equal to 1, leading to a linear elastic relation between p and V : however, qualitative as well as quantitative experimental analyses highlight that such deformable cuff shows a more complex behavior during inflation, resulting in a very high compliance during the initial deformation whereas its stiffness raises significantly as the volume increases [15]. This kind of behavior seems to suggest considering a non-linear constitutive relation in order to describe the mechanical characteristic of the cuff. Soft tissues also share similar mechanical characteristics, as reported in the literature [25, 26]. Therefore, the overall mechanical characteristic of the system depends on the interaction between the cuff and the limb. In this framework, the proposed simplified model may provide accurate enough results only for configurations like the one presented in this work, as it is still very difficult and challenging to define a feasible and general model for such a complex system involving the interaction between a deformable cuff and the human body tissues. This behavior becomes even more evident for quick events as high amplitude stimulations (200 mmHg)

lasting few seconds, since the cuff suddenly changes its volume and the dynamics becomes more relevant. In these conditions the viscous term could also considerably affect the performance of both the real system and the model, requiring an appropriate tuning of the parameter β (viscous coefficient).

The k parameter has been identified considering the ratio between the maximum relative pressure and the corresponding cuff volume change, confirming the order of magnitude of the data already reported in the literature [15]. Most of the simulations performed with long lasting stimulations (over 20 seconds) have been conducted by choosing n equal to 1 because of the slow dynamics of the trial, whereas the effect of higher degree elastic polynomial laws has been studied in the case of quick stimulations. In order to evaluate this effect on the performance of the system, the system behavior has been simulated for different degrees n of the polynomial elastic term. Figure 4 shows the outcomes of the simulations and the comparison with experimental pressure signals measured during a stimulation lasting about 2 seconds with set level equal to 200 mmHg. This trial has been chosen so as to make clearer the effect of the different modeling of the human-machine interaction (in terms of mechanical behavior) on the overall performance of the system, since the dynamics becomes even more relevant than in the previous analyses. It is clear that the implementation of a non-linear characteristic provides a substantial improvement in matching between the model and the experimental data. Nevertheless, it should be necessary to evaluate the robustness of these results by further comparison with a wider set of data collected from the physical system. A potential generalization of such outcomes could be possible only by means of a focused and precise characterization of such human-machine interaction, even though this may be a very challenging process, as it is affected by the characteristics of the specific cuff used and of the limb tissues involved.

Due to its difficult experimental evaluation, β has been tuned through a parametric analysis that is by the comparison between the results of the model and the experimental data provided by the pressure transducer. The model has been run for different values of the viscous coefficient β , and the results are

reported in Fig. 5. The behavior of the model seems to be quite close to the experimental data for values of the viscous coefficient up to 0.7 MPa s/m^3 , whereas higher values lead to a significantly slower system. Of course, this kind of result cannot be assumed as general enough to be adopted for a wide set of applications due to the highly specific context in which it has been evaluated. However, this outcome proved to be accurate enough for the tuning of the model, resulting in a similar dynamic response of the system provided by simulations with respect to the pressure data measured by the transducer.

The mathematical model of the cuff includes the description of the mechanical characteristic, as conveyed by Eq. (1), as well as the relationship between the mass flow rate and the pressure inside the cuff, given by the continuity equation (Eq. (2)):

$$G_1 = \frac{V_{i1} + \frac{p_1}{k} - \frac{\beta}{k} \frac{dV_1}{dt}}{RT} \frac{dP_1}{dt} + \frac{P_1}{RT} \frac{dV_1}{dt} \quad (2)$$

where P_1 is the absolute internal pressure, G_1 is the mass flow rate of air, T is the internal temperature and R is the air constant. This model is very simple and could be used to evaluate the performance of the system in a first approximation. However, it is not capable to reproduce the non-uniform inflating/deflating of the cuff which is highlighted during experimentation, occurring progressively from the inlet towards the remaining part of the cuff.

For these reasons, a second model, based on a two-stage collapsible volume (Fig. 6), has then been considered. While the mechanical characteristic of each chamber has been still described by the model presented in Eq. (1), Eq. (2) has been modified in order to consider both stages, as presented in Eq. (3):

$$G_1 - G_2 = \frac{V_{i1} + \frac{p_1}{k} - \frac{\beta}{k} \frac{dV_1}{dt}}{RT} \frac{dP_1}{dt} + \frac{P_1}{RT} \frac{dV_1}{dt}, \quad G_2 = \frac{V_{i2} + \frac{p_2}{k} - \frac{\beta}{k} \frac{dV_2}{dt}}{RT} \frac{dP_2}{dt} + \frac{P_2}{RT} \frac{dV_2}{dt} \quad (3)$$

where the symbols have the same meaning as the one reported above, and the numbers 1 and 2 refer respectively to the first and second chamber. Since the PT is placed near the inlet of the cuff, p_1 is equal to the sampled pressure signal fed back to the control system (thus the dynamics of the sensor has been

neglected). Fixed the expected variation of the cuff volume and the initial total volume V_i , it is possible to reproduce different inflating and deflating conditions by changing the volume fraction (i.e. the percentages of each chamber volume with respect to the total cuff volume). A pneumatic resistance between the two volumes has been considered, resulting in the following relation between the absolute pressures P_1 and P_2 (Eq. (4)):

$$P_1 - P_2 = R_v G_2 \tag{4}$$

where R_v is the value of the pneumatic resistance. The role of this fictitious resistance is to modulate the flow rate towards the second chamber G_2 , resulting in an uneven inflation and deflation of the cuff. This parameter has been set by iterative tuning in order to find the appropriate fitting between the model and the experimental data. The final value, reported in Table 1, yields a peak value of the flow rate G_2 about 75% lower than G_1 .

2.3.2 Model of the digital solenoid valves

The digital valves have been modeled according to the ISO 6358 [27]. The mass air flow rate passing through the valve is calculated in sonic or subsonic condition depending on the ratio between the downstream and upstream pressures. The relations are presented in Eq. (5):

$$G = \rho_0 P_{us} C \text{ for } 0 < \frac{P_{ds}}{P_{us}} \leq b, \quad G = \rho_0 P_{us} C \sqrt{1 - \left(\frac{P_{ds} / P_{us} - b}{1 - b} \right)^2} \text{ for } b < \frac{P_{ds}}{P_{us}} \leq 1 \tag{5}$$

where P_{us} is the upstream absolute pressure, P_{ds} is the downstream absolute pressure and ρ_0 is the air density in normal conditions. The sonic conductance C and the critical ratio b have been deduced considering the data given by the manufacturer and are collected in Table 1. The dynamic relation between the command signals (u_{DV1} , u_{DV2}) and the variation of conductance for each valve has been modeled by means of a first order transfer function, whose time constant τ_v has been estimated from the manufacturer data. The upstream and downstream pressures have been defined separately for each valve: the DV1 has the upstream pressure set as the supply pressure (by default 1.3 bar) and the inner cuff pressure

p_l set as the downstream one; the DV2 has p_l set as the upstream pressure and the atmospheric pressure set as the downstream one. Considering the difference between the drops of pressure on the DV1 and the DV2 during a typical working condition, the air flow rate passing through the former valve can be estimated as significantly higher than the one passing through the latter, resulting in a deflating phase lasting longer than the inflating one. This feature has been confirmed by the outcomes of the model and of the analysis of the experimental prototype.

2.3.3 Model of the pressure proportional valve

According to the literature [28], the PPV can be modeled as a first order system (Fig. 7) in which the output flow rate G_{PPV} depends on the difference between the measured pressure p_l and the set pressure p_{PPV} generated by the control system, given the pressure reference signal p_{ref} . As depicted in Fig. 2, the flow rate G_l (positive when entering the cuff) is given by the algebraic sum of G_{PPV} , G_{DV1} and G_{DV2} . The sign of the last term, i.e. the flow rate passing through the DV2, is defined positive when the discharge from the cuff to the ambient occurs. The parameters K_p , K_{PPV} and τ_{PPV} , respectively the PT gain, the static gain and the time constant of the PPV, have been estimated from the data-sheets of the components. In particular, the valve static gain has been calculated from the mean slope of the trend lines given by linear regression of the experimental pressure vs flow rate curves provided by the manufacturer [28].

2.4 General pattern of the control law for model simulation

The analytical model has been implemented in MATLAB-Simulink® (R2018a). First, simulations compared with experimental tests have been carried out to validate the model, then further simulations have been performed in several conditions to evaluate the system performance. The general pattern of the control law adopted in the simulations is the following:

- Inflating phase: DV1 and PPV are switched on with a defined set value (e.g 50 mmHg, 200 mmHg);

- Set level control phase: DV1 is switched off as soon as the set values is reached, PPV is active for the entire duration of the stimulation (depending on the specific trial);
- Deflating phase: PPV is switched off, DV2 is switched on;
- Rest phase: all valves switched off.

In general, the pressure reference has been set at 50 mmHg, that is a typical stimulation amplitude, held at constant level for about 25 s. If not specified, each simulation has been performed selecting the default parameters reported in Table 1 and the double-stage cuff model, with a volume fraction (for each chamber) of 50 % and choosing a linear relationship between the cuff pressure and the volume variation in the elastic term of the cuff constitutive equation (Eq. (1) with $n = 1$).

3 Results of model simulation and first in-vivo experience

3.1 Comparison between the single- and double-stage cuff model

In this subsection the cuff pressure measured by the transducer is compared with the outcomes of the simulations in two different conditions, i.e. considering the cuff modeled as a single collapsible chamber or as a double-stage collapsible volume (two deformable chambers in series). Figure 8 shows the results of the analysis: the model response is close to the experimental data in both conditions, however a more accurate result is highlighted for the double-stage model.

3.2 Dynamic performance of the system for different set pressure levels and supply pressures

First of all, the performance of the system has been evaluated by simulations carried out with different amplitudes (50 to 200 mmHg) of the pressure reference signal. In each condition, the parameters of the step response have been calculated and normalized (the maximum values are collected in Table 2). Figure 9 shows the outcomes of these simulations.

In case that the dynamic response parameters would not fulfill the design requirements, it may be necessary to substitute a component (e.g. the DV1) or to reduce the length of the air flow paths (e.g. having the valves as close as possible to the cuff) or to increase the supply pressure of the valves. While

the variation of the PPV supply pressure did not provide any significant improvement in the dynamic response of the system, due to the low mass flow rate passing through the valve, the effect of different supply pressures of the DV1 has been investigated. The results, in terms of the normalized step response parameters, are represented in Fig. 10

3.3 Effect of different volume fractions in the double-stage collapsible model of the cuff

In this subsection the effect of different choices of the volume fractions (i.e. the percentages of each chamber volumes with respect to the total cuff volume) in the double-stage cuff model has been investigated. This could be relevant to analyze the performance of the system for different wrapping conditions of the cuff around the limb of a patient. Figure 11 shows the cuff pressure and volume signals for several volume fraction values.

3.4 Results of experimental analysis on healthy subjects

A first in-vivo analysis on healthy subjects has been carried out at the Integrative Physiology Lab, Dept. of Neuroscience, University of Torino, under the approval of the local Ethics Committee. Aiming at the investigation of the role of different factors in the development of post-compression hyperaemia, several patterns for compression of the lower limb were required:

- a) single compression at 10-50 mmHg lasting 50 s;
- b) a short compression at 200 mmHg, lasting 1 s;
- c) complex compression pattern consisting of a combination of the a) and b) patterns, i.e. with an initial long-lasting pre-compression at 20 mmHg, followed by a fast compression at 200 mmHg and then by a complete cuff deflation.

Different patterns are needed to investigate the contribution of diverse factors in the development of hyperaemia. The capability of the pneumo-tronic device to hold a constant value of cuff pressure during stationary periods and to track sudden changes of internal pressure from one state to another is very important since it would improve the repeatability of the stimulations, as well as their temporal local-

ization. The cuff was wrapped around the fully extended left leg of the subject, placed horizontally. During these compressions, the blood flow of the femoral artery (FBF) was measured by Doppler sonography (Mylab 25, ESAOTE). Figure 12 shows an example of the outcomes (cuff pressure and FBF) of a test performed with a complex pattern consisting of the series of a long-lasting pre-compression and a subsequent quick stimulation with peak level of 200 mmHg. This kind of pattern may be used to control the filling of blood vessels, of the venous compartment in particular, before the delivery of the high-magnitude compression. The bottom plot shows the pressure signal measured by the transducer and sampled at 100 Hz by the data acquisition system. The upper part shows the flow response registered in the femoral artery by the eco-Doppler probe, highlighting a significant increase of FBF occurring after the 200 mmHg impulse.

4 Discussion

The preliminary experimental trials of the pneumo-tronic device led to the selection of the most effective solution of the pneumatic circuit, i.e. the one with the pressure proportional valve PPV working in parallel with the two digital valves DV1 and DV2 (section 2.1). This solution proved to be the one with the most accurate control of the pressure reference signal, thus providing good dynamic behavior. Therefore, the performance of the system and of the model has been evaluated by several trials.

The analytical model described in section 2.3 has been evaluated by comparison with the experimental data collected in laboratory. First of all, the proposition of a double-stage model of the collapsible cuff volume has been evaluated, highlighting a better tracking of the behavior showed by the real system with respect to a single-stage model. The deflating phase emerging from the simulations appears to be slower than the one occurring in the real system, probably because of inaccuracies in the modelling of the cuff. The choice of a more refined relationship between the variation of the internal cuff pressure and the deformation of the cuff would probably provide a better result (as pointed out in

section 2.3.1). However, both the model and the real system highlight the ability of the pneumo-tronic system to keep a constant level of pressure inside the cuff. Of course, this outcome is far more relevant for the experimental system because of the presence of air losses which were not taken into account during the definition of the model.

Then, the ability of both the real system and the model to track the reference pressure signal has been evaluated for different pressure levels. In these conditions, the parameters of the dynamic response have been calculated (Table 2) and discussed. While the settling time (the time it takes for the difference between the system response and the steady-state response to fall below 2 % of the peak value) is not greatly influenced by the amplitude of the pressure reference since it mainly depends on the performance of the PPV, the other parameters seem to be far more conditioned by the set pressure required. The rise time, peak time and discharge time (calculated according to the ISO 12238) almost linearly increase due to the rise of the pressure reference. This result was predictable given the effect of the non-linearities included in the system. This phenomenon is critical especially during the inflating phase that depends substantially on the mass flow rate passing through the DV1. Nonetheless, the dynamic response parameters evaluated by simulations can still be considered as satisfactory for the application, since the vascular phenomena to be investigated have low dynamics and often require long lasting stimulations (over 20 s).

Then, the effect of a variation in the DV1 supply pressure on the dynamic behavior of the system has been evaluated, showing that the increase in the supply pressure reduces the rise time and peak time significantly, almost linearly between 1 and 3 bar. Beyond the latter, they settle at an almost constant level (about 40 % of the maximum for the rise time, about 50 % of the maximum for the peak time). The settling time is not very influenced by the increase of the level of supply pressure, whereas the overshoot (percentage overshoot relative to the steady-state response, normalized with respect to the maximum value calculated) shows a constant growth. To avoid undesired peak levels of cuff pressure, that may be

excessive for the patient as well as for the integrity of the cuff, it seems to be recommended to not exceed 3-4 bar of the DV1 supply pressure.

To consider different wrapping conditions of the cuff around the subject's limb, the behavior of the system for several volume fractions (in the double-stage model) has been analyzed. Although the behavior of the system for two limit conditions (when the volume of the first chamber reaches the 20% or 80% of the whole cuff volume) significantly differs from the one evidenced by experimental trials, the overall performance of the device seems to not critically deteriorate, as the system is still able to reach the desired set pressure level and to keep it for the required period of time. This outcome proved the overall robustness of the system with respect to changes in the nonuniform distribution of air in the cuff.

Finally, the system has been tested on a set of healthy subjects, so as to present a specific clinical application of such device. The performance of the system still needs to be assessed in different types of subjects and patients, including elderly people and obese patients, to address possible effects due to different mechanical characteristics of the tissues and different size of the limbs. However, the first clinical experimentation highlighted the ability of the system to apply complex and customizable compressive patterns (e.g. given by the composition of a pre-compression, a quick high-amplitude compression followed by a full discharge) to the limbs of the subjects with the required dynamic accuracy. This allows for precise temporal localization of the compressive stimulus and therefore the assessment of the vascular response latency is possible. Moreover, the device is able to hold a constant pressure for an indefinite time. This can be useful to investigate the effects of reducing vascular filling in venous compartments and of altering vascular transmural pressure levels on limb perfusion and on the hyperaemic response to compression. In addition to serving research purposes, such as the investigation of the physiological mechanisms underlying the compression-induced hyperaemia, this system may find application in the clinical setting, e.g., in refining/tailoring the compressive pattern of classical intermittent pneumatic compression treatments.

5 Conclusion

This paper presents a pneumo-tronic system aimed at deepening the knowledge about a physiological phenomenon, known as compression-induced hyperaemia, and defining the appropriate experimental protocols. From the design point of view, the required specifications, fast response time and high accuracy in the given range of pressure and flow rate are particularly difficult to obtain in a standard pneumatic system. For this reason, in the absence of a suitable commercial device, it was necessary to design a new device in which high-power digital valves are used in conjunction with small size high-accuracy pneumo-electronic components.

A mathematical model with lumped parameters has been realized with the aim of investigating the system's response to the variation of some parameters. Since the device works in contact with the human body, the mathematical model must be able to suitably describe human-machine interaction. By combining experimental characterization and numerical simulations, a tuning phase was then performed, both for the device and for the control logic parameters, in order to obtain a good compromise on system requirements.

The final pneumo-tronic device proves itself able to generate sharp pressure stimulations and to deliver customizable patterns of compressive stimuli to the limb of a subject or of a patient over a wide pressure range and with good dynamic performance. The device is currently being employed in an experimental series investigating the mechanisms that regulate compression-induced hyperaemia. Improved understanding of the underlying physiological mechanisms will help to optimize clinical protocols and treatments based on pneumatic limb compression.

References

- [1] Morris R J. Intermittent pneumatic compression – systems and applications. *Journal of Medical Engineering and Technology*, 2008, **32**, 179–188.
- [2] Partsch H. Intermittent pneumatic compression in immobile patients. *International Wound Journal*, 2008, **5**, 389–397.
- [3] Johansson K, Lie E, Ekdahl C, Lindfeldt J. A randomized study comparing manual lymph drainage with sequential pneumatic compression for treatment of postoperative arm lymphedema. *Lymphology*, 1998, **31**, 56–64.
- [4] Comerota A J. Intermittent pneumatic compression: physiologic and clinical basis to improve management of venous leg ulcers. *Journal of Vascular Surgery*, 2011, **53**, 1121–1129.
- [5] Nelson E A, Mani R, Thomas K, Vowden K. Intermittent pneumatic compression for treating venous leg ulcers. *Cochrane Database of Systematic Reviews*, 2011, **2**.
- [6] Flam E, Berry S, Coyle A, Dardik H, Raab L. Blood-flow augmentation of intermittent pneumatic compression systems used for the prevention of deep vein thrombosis prior to surgery. *The American Journal of Surgery*, 1996, **171**, 312–315.
- [7] Waller T, Caine M, Morris R. Intermittent pneumatic compression technology for sports recovery. *The Engineering of Sport*, 2006, **3**, 391–396.
- [8] Wiener A, Mizrahi J, Verbitsky. Enhancement of tibialis anterior recovery by intermittent sequential pneumatic compression of the legs. *Basic and Applied Myology*, 2001, **11**, 87–90.
- [9] Christen Y, Wutscher R, Weimer D, de Moerloose P, Kruithof E K, Bounameaux H. Effects of intermittent pneumatic compression on venous haemodynamics and fibrinolytic activity. *Blood Coagulation & Fibrinolysis*, 1997, **8**, 185–190.
- [10] Lurie F, Scott V, Yoon H C, Kistner R L. On the mechanism of action of pneumatic compression devices: combined magnetic resonance imaging and duplex ultrasound investigation. *Journal of Vascular Surgery*, 2008, **48**, 1000–1006.
- [11] Sheldon R D, Roseguini B T, Laughlin M H, Newcomer S C. New insights into the physiologic basis for intermittent pneumatic limb compression as a therapeutic strategy for peripheral artery disease. *Journal of Vascular Surgery*, 2013, **58**, 1688–1696.
- [12] Ferraresi C, Hajimirzaalian H, Maffiodo D. Identification of physical parameters in a robotized IPC device interacting with human. *Applied Mechanics and Materials*, 2014, **490-491**, 1729–1733.
- [13] Ferraresi C, Maffiodo D, Hajimirzaalian H. Simulation and control of a robotic device for cardio-circulatory rehabilitation. *Advances in Intelligent Systems and Computing*, 2016, **371**, 357–365.
- [14] Manuello Bertetto A, Meili S, Ferraresi C, Maffiodo D, Crisafulli A, Concu A. A mechatronic pneumatic device to improve diastolic function by intermittent action on lower limbs. *International Journal of Automation Technology*, 2017, **11**, 501–508.
- [15] Ferraresi C, Maffiodo D, Hajimirzaalian H. A model-based method for the design of intermittent pneumatic compression systems acting on humans. *Proceedings of the Institution of Mechanical Engineers, Part H: Journal of Engineering in Medicine*, 2014, **228**, 118–126.
- [16] Maffiodo D, De Nisco G, Gallo D, Audenino A, Morbiducci U, Ferraresi C. A reduced-order model-based study on the effect of intermittent pneumatic compression of limbs on the cardiovascular system. *Proceedings of the Institution of Mechanical Engineers, Part H: Journal of Engineering in Medicine*, 2016, **230**, 279–287.
- [17] Messere A, Ceravolo G, Franco W, Maffiodo D, Ferraresi C, Roatta S. Increased tissue oxygenation explains the attenuation of hyperemia upon repetitive pneumatic compression of the lower leg. *Journal of Applied Physiology*, 2017, **123**, 1451–1460.

- [18] Messere A, Turturici M, Millo G, Roatta S. Repetitive muscle compression reduces vascular mechano-sensitivity and the hyperemic response to muscle contraction. *Journal of Physiology and Pharmacology*, 2017, **68**, 427–437.
- [19] Jasperse J L, Shoemaker J K, Gray E J, Clifford P S. Positional differences in reactive hyperemia provide insight into initial phase of exercise hyperemia. *Journal of Applied Physiology*, 2015, **119**, 569–575.
- [20] Messere A, Tschakovsky M, Seddone S, Lulli G, Franco W, Maffiodo D, Ferraresi C, Roatta S. Hyper-oxygenation attenuates the rapid vasodilatory response to muscle contraction and compression. *Frontiers in Physiology*, 2018, **9**:1078.
- [21] Turturici M, Mohammed M, Roatta S. Evidence that the contraction-induced rapid hyperemia in rabbit masseter muscle is based on a mechanosensitive mechanism, not shared by cutaneous vascular beds. *Journal of Applied Physiology*, 2012, **113**, 524–531.
- [22] Turturici M, Roatta S. Inactivation of mechano-sensitive dilatation upon repetitive mechanical stimulation of the musculo-vascular network in the rabbit. *Journal of Physiology and Pharmacology*, 2013, **64**, 299–308.
- [23] Messere A, Pertusio R, Macrì C, Maffiodo D, Franco W, De Benedictis C, Ferraresi C, Roatta S. Delivery of customizable compressive patterns to human limbs to investigate vascular reactivity. *Biomedical Physics & Engineering Express*, 2018, **4**, 067003.
- [24] Ferraresi C, De Benedictis C, Maffiodo D, Franco W, Messere A, Pertusio R, Roatta S. A novel pneumatic device for the investigation of compression-induced physiological phenomena: Modeling and experimental testing. *Mechanisms and Machine Science*, 2019, **65**, 207–215.
- [25] Clemen C B, Benderoth G, Schmidt A, Hübner F, Vogl T J, Silber G. Human skeletal muscle behavior in vivo: Finite element implementation, experiment, and passive mechanical characterization. *Journal of the mechanical behavior of biomedical materials*, 2017, **65**, 679–687
- [26] Affagard J, Bensamoun S F, Feissel P. Development of an inverse approach for the characterization of in vivo mechanical properties of the lower limb muscles. ASME. *Journal of Biomechanical Engineering*, 2014, **136**, 111012-1–111012-8.
- [27] Ferraresi C. Modelling of pneumatic systems. *Fluid Apparecchiature Idrauliche & Pneumatiche*, 1993, **346**, 48–54.
- [28] Ferraresi C, Sorli M. Modelling and analysis of pressure control systems. *Fluid Apparecchiature Idrauliche & Pneumatiche*, 1994, **357**, 58–65.

Figures

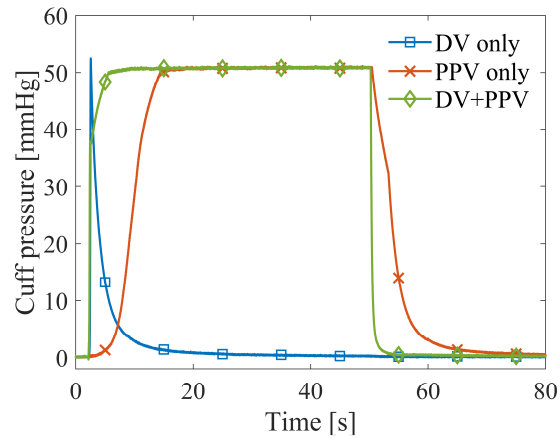

Fig. 1 Cuff pressure measured for three different solutions: two digital valves for inflating and deflating (DV only), a single pressure proportional valve (PPV only), the combination of a pressure proportional valve and the two digital valves (DV+PPV).

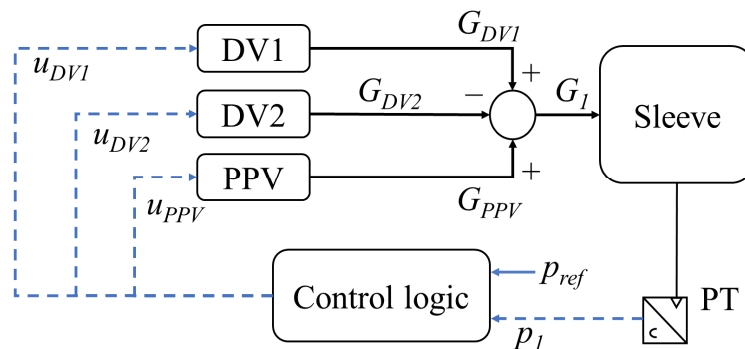

Fig. 2 Scheme of the pneumo-tronic system. DV1 and DV2 are two digital solenoid valves respectively used for cuff inflating and deflating, PPV is the pressure proportional valve, PT is the pressure transducer. The command signal and the output mass flow rate are reported for each valve.

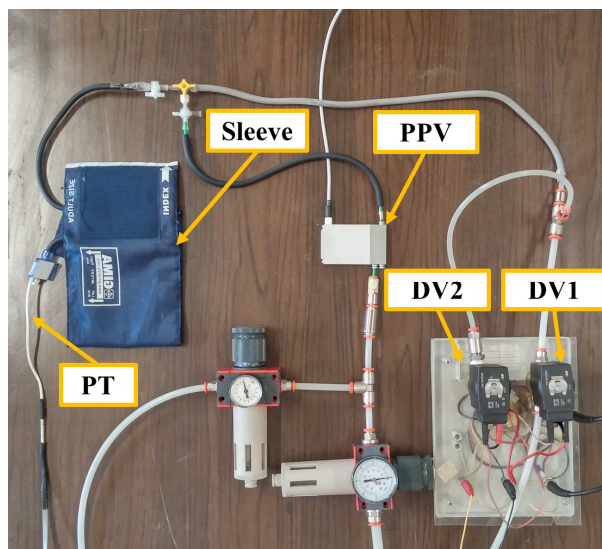

Fig. 3 Picture of the pneumo-tronic system. DV1 and DV2 are two digital solenoid valves respectively used for cuff inflating and deflating, PPV is the pressure proportional valve, PT is the pressure transducer.

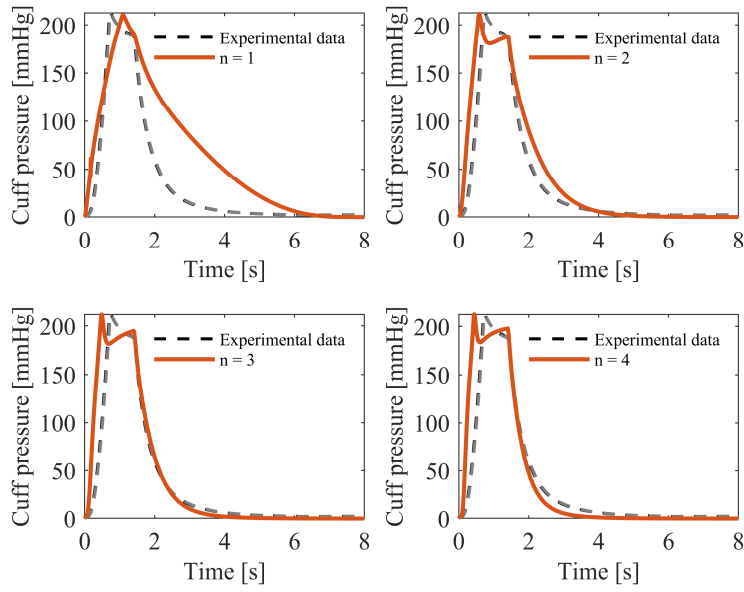

Fig. 4 Response of the real system and of the model for different choices of the elastic term degree n , 200 mmHg of reference pressure.

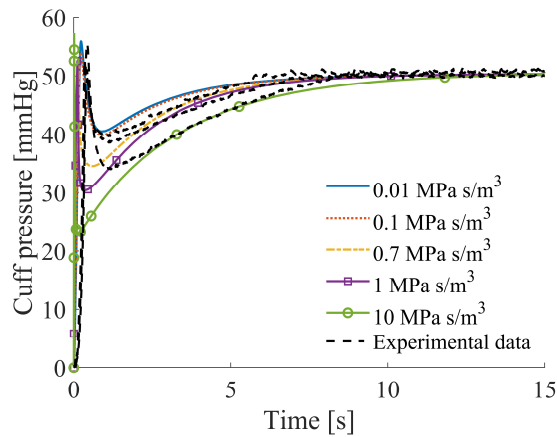

Fig. 5 Response of the real system and of the model for different choices of the viscous constant β , 50 mmHg of reference pressure.

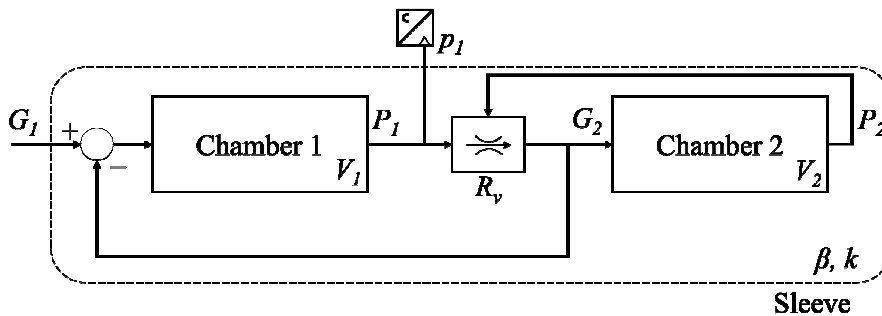

Fig. 6 Double-stage collapsible volume model of the cuff.

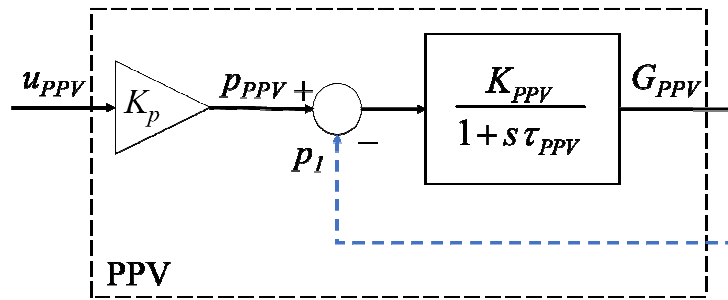

Fig. 7 Scheme of the pressure proportional valve (PPV) model.

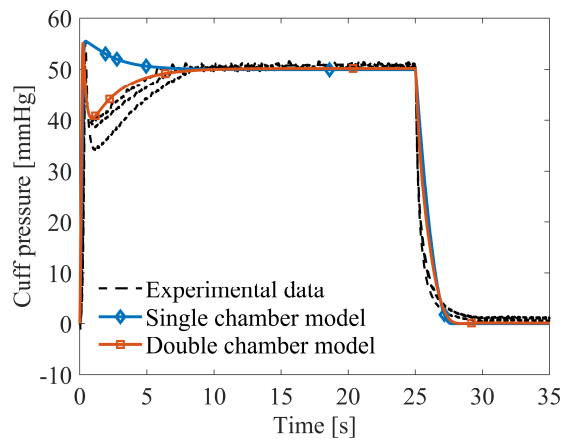

Fig. 8 Comparison between the single- and double-stage collapsible volume model of the cuff, 50 mmHg of reference pressure.

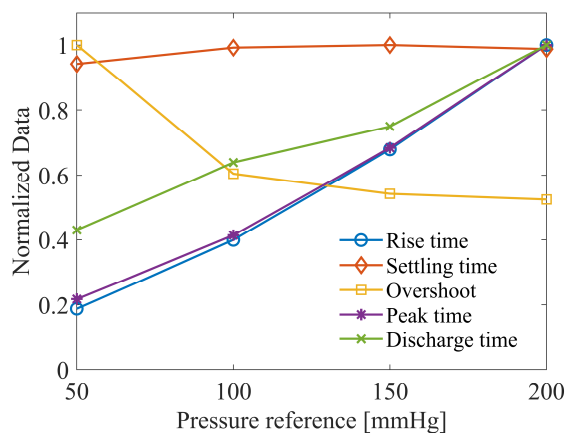

Fig. 9 Normalized step response parameters for several set pressures amplitudes (50-200 mmHg).

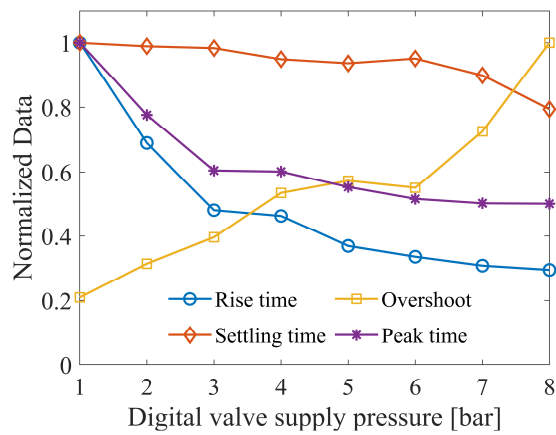

Fig. 10 Normalized step response parameters for several DV1 supply pressures, 50 mmHg of reference pressure.

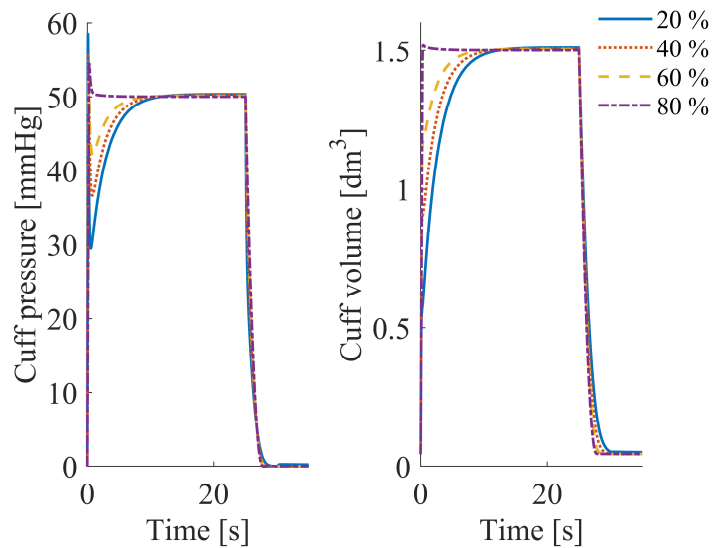

Fig. 11 Cuff pressure (left) and volume (right) for different volume fraction values (i.e. the ratio between the first chamber volume and the total cuff volume), 50 mmHg of reference pressure.

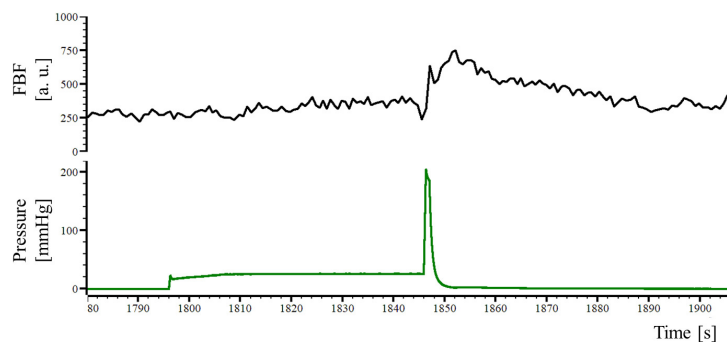

Fig. 12 Recordings of a post-compression hyperaemia from a representative subject: femoral artery blood flow (FBF) and cuff pressure.

Tables

Table 1 Default parameters of the system

Parameter	Value
V_i (cm ³)	44
β (kPa s/m ³)	10
k (MPa/m ³)	4.06
R_v (MPa s/kg)	3.5
C (Nm ³ /(Pa s))	$2.3 \cdot 10^{-8}$
b	0.46
τ_v (ms)	30
τ_{PPV} (ms)	25
K_p (kPa/V)	20
K_{PPV} (kg/(Pa s))	$9.22 \cdot 10^{-9}$
R (J/(kg K))	287.1
T (K)	293
ρ_0 (kg/m ³)	1.188

Table 2 Maximum values of the dynamic response parameters calculated for several set pressures

Parameter	Value
Rise time (s)	0.76
Settling time (s)	6.31
Overshoot (%)	9.97
Peak time (s)	1.09
Discharge time (s)	3.95

Figure captions

- Fig. 1** Cuff pressure measured for three different solutions: two digital valves for inflating and deflating (DV only), a single pressure proportional valve (PPV only), the combination of a pressure proportional valve and the two digital valves (DV+PPV).
- Fig. 2** Scheme of the pneumo-tronic system. DV1 and DV2 are two digital solenoid valves respectively used for cuff inflating and de-flating, PPV is the pressure proportional valve, PT is the pressure transducer. The command signal and the output mass flow rate are reported for each valve.
- Fig. 3** Scheme of the pneumo-tronic system. DV1 and DV2 are two digital solenoid valves respectively used for cuff inflating and de-flating, PPV is the pressure proportional valve, PT is the pressure transducer.
- Fig. 4** Response of the real system and of the model for different choices of the elastic term degree n , 200 mmHg of reference pressure.
- Fig. 5** Response of the real system and of the model for different choices of the viscous constant β , 50 mmHg of reference pressure.
- Fig. 6** Double-stage collapsible volume model of the cuff.
- Fig. 7** Scheme of the pressure proportional valve (PPV) model.
- Fig. 8** Comparison between the single- and double-stage collapsible volume model of the cuff, 50 mmHg of reference pressure.
- Fig. 9** Normalized step response parameters for several set pressures amplitudes (50-200 mmHg).
- Fig. 10** Normalized step response parameters for several DV1 supply pressures, 50 mmHg of reference pressure.
- Fig. 11** Cuff pressure (left) and volume (right) for different volume fraction values (i.e. the ratio between the first chamber volume and the total cuff volume), 50 mmHg of reference pressure.
- Fig. 12** Recordings of a post-compression hyperaemia from a representative subject: femoral artery blood flow (FBF) and cuff pressure.