

Metaheuristic Bio-Inspired Algorithms for Prognostics: Application to On-Board Electromechanical Actuators

*Original*

Metaheuristic Bio-Inspired Algorithms for Prognostics: Application to On-Board Electromechanical Actuators / Dalla Vedova, Matteo D. L.; Berri, PIER CARLO; Re, Stefano. - ELETTRONICO. - (2018). ( 3rd International Conference on System Reliability and Safety (ICSRS 2018) Barcellona (Spain) 24-26/11/2018).

*Availability:*

This version is available at: 11583/2729980 since: 2019-04-04T11:55:34Z

*Publisher:*

IEEE

*Published*

DOI:

*Terms of use:*

This article is made available under terms and conditions as specified in the corresponding bibliographic description in the repository

*Publisher copyright*

IEEE postprint/Author's Accepted Manuscript

©2018 IEEE. Personal use of this material is permitted. Permission from IEEE must be obtained for all other uses, in any current or future media, including reprinting/republishing this material for advertising or promotional purposes, creating new collecting works, for resale or lists, or reuse of any copyrighted component of this work in other works.

(Article begins on next page)

# Metaheuristic Bio-Inspired Algorithms for Prognostics: Application to On-Board Electromechanical Actuators

Matteo D. L. Dalla Vedova   Pier Carlo Berri   Stefano Re  
Department of Mechanical and Aerospace Engineering  
Politecnico di Torino  
Corso Duca degli Abruzzi 24, Italy  
matteo.dallavedova@polito.it

**Abstract**—Metaheuristic bio inspired algorithms are a wide class of optimization algorithms, which recently saw a significant growth due to its effectiveness for the solution of complex problems. In this preliminary work, we assess the performance of two of these algorithms - Genetic Algorithm (GA) and Particle Swarm Optimization (PSO) – for the prognostic analysis of an electro-mechanical flight control actuator, powered by a Brushless DC (BLDC) trapezoidal motor. We focus on the first step of the prognostic process, consisting in an early Fault Detection and Identification (FDI); our model-based strategy consists in using an optimization algorithm to approximate the output of the physical system with a computationally light Monitor Model.

**Keywords**-component; metaheuristic bio-inspired algorithms; PHM; model-based approach; BLDC motor; EMA; GA; PSO

## I. INTRODUCTION

In the last decades, several researches [1-3] showed the advantages introduced by the conversion of most aircraft secondary systems to electrical power; these benefits range from weight reduction to fuel savings and simpler maintenance. In this context, Electromechanical Actuators (EMAs) are progressively replacing the traditional hydraulic and pneumatic actuation systems for aerospace applications. However, EMAs are not ready for flight critical or mission critical functions such as primary flight controls, since important issues like poor heat dissipation, low reliability and susceptibility to EMI interferences (e.g. EMC and ESD issues) still need to be overcome. Hence Prognostics and Health Management (PHM) disciplines gain high relevance to enable the fulfillment of the more-electric and all-electric aircraft design paradigms [2, 3]. The PHM approach to a product life-cycle aims at continuously estimate the system Remaining Useful Life (RUL), i.e. to predict the moment when the object of the study will no more be able to operate within its stated specifications [4, 6]. The first necessary step for the RUL estimation of a system is a precise and early identification of the components health status; then, we focus on the FDI task using a model-based strategy, and testing the performance of different meta-heuristic optimization algorithms. This work constitutes a preliminary study to assess the applicability of our methodology.

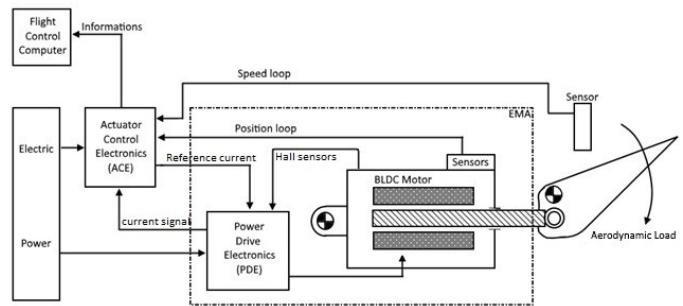

Figure 1. Schematic of the considered EMA.

Figure 1 shows the high-level architecture of the EMA studied in this work. The main subsystems of the actuator are briefly listed in the following paragraph:

- The *Actuator Control Electronics (ACE)* subsystem applies the control law intended to minimize the error between the actual and commanded positions.
- The *Power Drive Electronics (PDE)* subsystem consists in a three-phase bridge and the related commutation logic to control the power flow to the electric motor.
- The *BLDC Motor* converts electrical power into mechanical power. A mechanical transmission connects its output to the aircraft control surface;
- *LVDT and Hall Sensors* are used to measure the feedback signals needed by the ACE and PDE.

Our strategy for FDI consists in comparing the output signals of the actual system (here replaced by a high-fidelity reference model) and a computationally light monitor model, to identify a set of fault parameters which encode the EMA health status. The analyzed output signal is the envelope of the three phase currents, for its availability and sensitivity to faults. An optimization algorithm iteratively updates the fault parameters to minimize the error between the measured and reconstructed signals; once convergence is reached, if the error is small enough, we assume that the current fault parameters correspond to the faults of the actual system. The optimization is performed by two different metaheuristic algorithms: Genetic Algorithms (GA) [7] and Particle Swarm Optimization (PSO) [8].

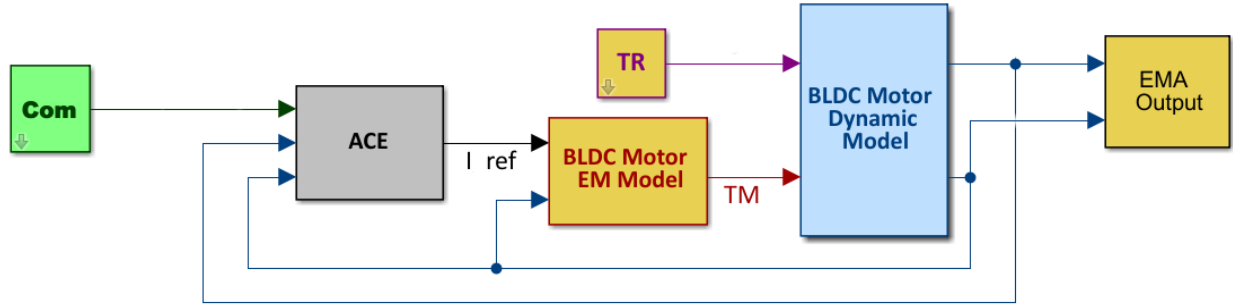

Figure 2. EMA reference model (RM) block diagram [13].

In the following paragraphs these two methods are discussed and compared in terms of precision, accuracy, computational costs (calculation burden and CPU time) and implementation complexity.

## II. EMA REFERENCE AND MONITORING MODELS

For this study, we employ two models of the considered system, characterized by different levels of accuracy and different computational costs: a high-fidelity (HF) Reference Model (RM) and a Low Fidelity (LF) Monitor Model (MM) [9-13]. The former is used as a simulated test-bench: the output of this model is taken as reference data replacing the acquisitions from physical sensors. The latter is computationally lighter, allowing for the iterative execution needed by the optimization algorithms.

Figure 2 shows a high-level block diagram of the Reference Model, containing four main functional subsystems:

- The *Com* block generates the position command given to the actuation system, expressed in radians;
- The *Actuator Control Electronics (ACE)* block implements the control law of the system, computing the reference current signal  $I_{ref}$ ;
- The *BLDC Motor EM Model* block implements the electromagnetic (EM) model on the BLDC motor simulating its dynamic behavior; in particular, it computes the driving torque as a function of the reference current and the back-EMF as a function of the motor speed.
- “*BLDC Motor Dynamic Model*” block converts the applied torque in the position of the end effector, returned to the ACE block to close the feedback loop.

This model, initially proposed by [12], is implemented in the Matlab-Simulink simulation environment and is capable of emulating the dynamic response of a typical on-board electromechanical actuation system powered by a three-phase BLDC trapezoidal motor. This model accounts for the effects of different progressive failure modes affecting the actuator. The faults can be injected in the model by modifying a set of simulation parameters: this way, it is possible to associate different combinations of faults to characteristic waveforms of the phase currents.

The monitor model (MM), shown in Figure 3 and widely described in [9], is a simplified representation of the real EMA system. The main difference with respect to the RM is the equivalent first order single-phase DC motor model to replace the detailed electromagnetic model of the BLDC motor. To this purpose, the authors introduced a shape function based model for the simulation of the electrical faults, which, although not strictly related to the physic governing laws of the system, allows emulating the RM behavior with acceptable accuracy [9, 10].

Hence, the MM is very effective to reduce significantly the computational effort while matching the motor current response of the low-fidelity model with that of the high-fidelity model.

## III. EMA FAULT MODES

Five different fault modes were considered for the study. Those were chosen among the most common for EMAs, as shown in [14-16]; moreover, they are usually characterized by a progressive growth, enabling an effective early prognostic detection. The considered faults are briefly listed below:

- Dry Friction Phenomena mainly descending from a progressive wear of bearings and mechanical transmission joints; typically they are complex to identify and modelling [17];
- Backlash affecting mechanical transmission, reducer gearboxes, hinges and/or rotary-to-linear conversion device (e.g. ballscrews); these types of failures are often due to progressive wear [18, 19];
- Progressive Short circuit (SC) faults affecting the stator coils of the three-phase BLDC motor [9];
- Rotor Static Eccentricity (RSE) fault, due to the degradation of its support bearings and calculated in terms of distance between the axis of symmetry of rotor and stator and the eccentricity phase (i.e. the orientation of the misalignment) [9];
- Control electronics fault resulting in the drift of the PID controller Proportional Gain [13].

The implementation of the first four faults in both the RM and MM is discussed in [13]. The last one is modeled by varying the proportional gain parameter in the controller subsystem of both models.

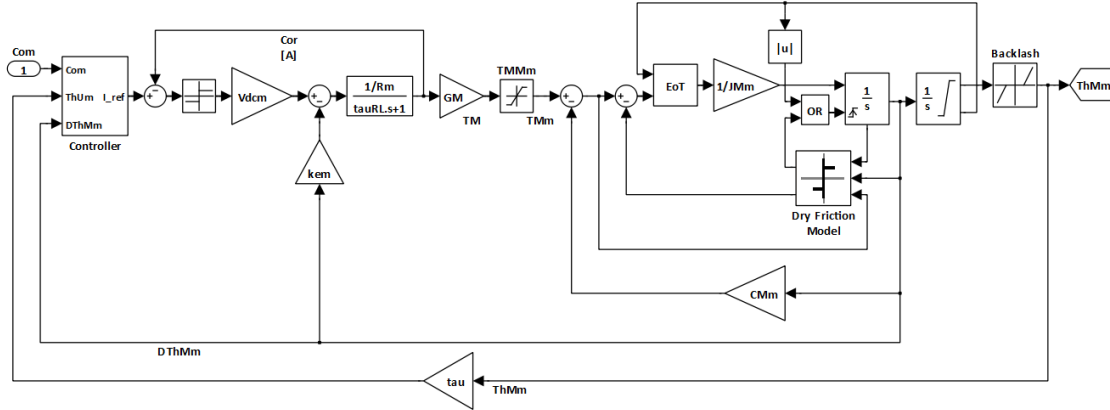

Figure 3. EMA monitoring model (MM) block diagram [3].

Despite the relatively simple implementation, the Fault Detection and Identification (FDI) of the proportional gain drift brings significant difficulties, mainly due to the position of the affected subsystem in the EMA feedback loop. In particular considering the interactions with other fault modes: in fact, its effects are hardly distinguishable from those of partial short circuit.

#### IV. FAULT DETECTION/IDENTIFICATION METHOD

In order to perform the FDI task, our proposed approach evaluates the waveform of the three phase currents comparing them with the equivalent response generated by the monitoring model. The choice of the current as monitored variable is justified by two reasons. First, the current signal has a high sensitivity to several different failure modes, both electrical and mechanical. Moreover, the phase currents are already measured for feedback purposes: then, they are available without installing additional sensors, which would increase costs and reduce overall reliability.

The FDI task is treated as an optimization problem, where the objective function is an error between reference and monitor current signals. Classical approaches to this class of problems can be sorted into deterministic and heuristics methods [20,21]. For our application, deterministic approaches are not adequate, since they usually feature a poor robustness when employed to the solution of complex and multi-modal problems. Heuristic and meta-heuristic algorithms are more robust, but particular attention shall be paid to the computational cost, since they tend to require a higher number of evaluations of the objective function. In this paper two heuristic methods are evaluated, inspired by the natural behavior of living beings. Two groups compose this family of bio-inspired optimization strategies: the Evolutionary Algorithms (EA) [20], based on the natural selection of species, and the Swarm Intelligence algorithms (SI) [22], inspired by the collective behavior of groups of animals. The authors compare an implementation of the Genetic Algorithms (GA) [7, 20, 23] among the EA and the Particle Swarm Optimization (PSO) [8] among the SI. Their performance for FDI applications are assessed in the following paragraphs.

#### V. OPTIMIZATION ALGORITHMS

Optimization means to identify the best acceptable solution for a given problem. Literature proposes several heuristic algorithms, either evolutionary or swarm-based.

Evolutionary algorithms [7, 20, 23] are the most common heuristic optimization methods. They emulate the natural evolution of the species on Earth to find a global minimum in a function. The iterative process used is composed by a series of sequential steps: growth, development, reproduction, selection and survival of the best individuals. At each iteration, the best solutions for the problem are selected. EA commonly used are genetic algorithms (GA), genetic programming (GP), differential evolution (DE), evolution strategies (ES) and the most recent paddy field algorithm. GA is a stochastic method proposed for the first time by Holland in 1975 [7]. It relies on the concept of natural selection introduced by Charles Darwin in his work "Origin of the species". The algorithm starts with the creation of a random population of solutions (called chromosomes), encoded in bit vectors. The fitting capability of each individual is evaluated with the fitness function (i.e. the objective function to be optimized). The best chromosomes are selected for crossover and mutation processes, to give birth to a new, better-fitted generation. This optimization is widely used when a deterministic approach is not available or when the domain knowledge is poor, i.e. when great robustness to multi-modal problems is required. The main disadvantages of this method are the high computational cost, usually unsuitable for online real-time applications, and the inherent non-deterministic behavior, which cannot guarantee convergence in the actual optimum solution. Swarm intelligence algorithms [8, 22] are based on the common behavior of a population, often represented by a group of animals. First theorists of these methodologies defined them: "Any attempt to design algorithms or distributed problem-solving devices inspired by the collective behavior of social insect colonies and other animal societies". These optimization strategies emulate the behavior of animals like ants, fireflies, frogs, bats, etc. when they are looking for their goal (i.e. usually food sources):

the nearer is the desired objective, the more insects you will find. They communicate each other in different ways, explore the entire domain and give feedback to other individuals. In this paper are reported the solution obtained with the particle swarm optimization (PSO), a stochastic, population-based technique, which it has been inspired by the behavior of a bird flock. It is widely used because of its simplicity, computational efficiency and easy implementation in a huge variety of engineering problems. In this algorithm, birds are assimilated as mass-and-volume-free particles, which move in the domain looking for the best food source. The objective function is computed for each particle, and the best value is stored. Then, the position of each particle within the design space is updated by taking into account the current velocity of the particle (effect of inertia), the memory of the best position found by the particle (effect of self-confidence) and the best position found by the swarm (effect of swarm confidence). The addition of a random disturbance improves the domain coverage and avoids the algorithm to get stuck in local minima.

## VI. PROPOSED FITNESS FUNCTION

The objective function to be optimized by the evolutionary algorithms is known as the fitness function. In the proposed FDI technique, it is computed as the cumulative error in terms of equivalent single-phase current between the MM and RM, as a function of the fault parameters. This results in an eight-variables scalar function, since two of the five considered fault modes have multiple degrees of freedom. Operatively speaking, the aim of the optimization is to find a suitable eight elements normalized vector  $\mathbf{k}$ , each factor encoding a fault parameter. Every element is normalized in the (0, 1) interval according to [13]:

$$\mathbf{k} = [k_1, k_2, k_3, k_4, k_5, k_6, k_7, k_8] \quad (1)$$

where:

- $k_1$  is the friction fault parameter, simulating a variation of the static and dynamic friction coefficients of the system [24] between one and three times the nominal condition;
- $k_2$  represents the backlash fault [24] and can vary from one to one hundred times the nominal value;
- $k_3, k_4$  and  $k_5$  are the short-circuit percentage for each phase of the BLDC motor: in fact, the partial short circuit can affect each of the three stator phases, which have to be treated separately in order to isolate this fault mode from the others [25] (e.g.  $k_3 = 0.8$  means that phase A is affected by a short-circuit condition involving 20% of its windings);
- $k_6$  and  $k_7$  are the fault parameters representing, respectively, the rotor static eccentricity in terms of magnitude  $\zeta$  and phase  $\phi$  (i.e. the angular position of the minimum air gap measured from the reference rotor angular position) [9, 10];
- $k_8$  is the proportional gain drift parameter, encoding a variation of the nominal gain between 50% and 150% of its nominal value.

The output of the fitness function is evaluated with a Total Least Squares Error [26]. This is preferred over a more classical Least Squares Error to avoid overestimating the objective function when the two EMA models gather a small phase lag in correspondence of abrupt changes of the current signals. The formulation of the error function between the reference envelope current  $I_{3equiv}$  and the monitor current  $I_m$  can be written as [10]:

$$err = \sum_i \frac{(I_{3equiv(i)} - I_{m(i)})^2}{\left(\frac{dI_{3equiv(i)}}{dt}\right)^2 + 1} \cdot C$$

where the time derivative of  $I_{3equiv}$  is normalized by its root mean squared value  $C$ .

## VII. RESULTS

To assess the performance of the two considered optimization algorithms in different conditions, each has been tested with a low-faults combination (defined as  $\hat{k}_i \leq 0.25$ ) and a high-faults combination ( $\hat{k}_i \geq 0.7$ ). In order to average out the stochastic behavior of the heuristic optimization algorithms, ten consecutive tests are executed for each test case. The settings of the optimization algorithms are calibrated to achieve a correct convergence on a benchmark problem, surrogate of the actual objective function, and they have been chosen after a long series of pre-tests. This benchmark problem shares the same characteristics of convexity, multi-modality, nonlinearity and constraints as the actual objective function, but requires a much lower computational time. This allows to quickly find a calibration of the optimization parameters which is expected to perform acceptably on the actual, computationally expensive problem. The aim is to compare the results obtained from different optimization algorithms, so some settings are chosen in common. For both GA and PSO, the authors employed a population / swarm size of 50 individuals, a maximum of 200 iterations and a function tolerance of  $10^{-9}$  as a stopping criterion. The reference current signals are generated by injecting a fault combination in the high fidelity model; then, the optimization algorithms use the monitor model to compute the objective function, attempting to match the reference current signal. As an example, Table I lists the optimal fault vectors obtained injecting a friction fault in the reference model and employing a GA optimization. The first row contains the actual fault parameters used to compute the reference signal with the high-fidelity model. The last column of Table I lists the relative errors for each attempt, defined as:

$$Err_{\%} = 100 \sqrt{\sum_{i=1}^6 (k_i - \hat{k}_i)^2 + \hat{k}_6 (k_7 - \hat{k}_7)^2 + (k_8 - \hat{k}_8)^2}$$

where  $\hat{\mathbf{k}} = [\hat{k}_1, \hat{k}_2, \hat{k}_3, \hat{k}_4, \hat{k}_5, \hat{k}_6, \hat{k}_7, \hat{k}_8]$  are the values of the reference vector.

TABLE I. RESULTS OF GA OPTIMIZATIONS IN PRESENCE OF A SMALL FRICTION FAULT

$\hat{k}$	0,25	0	0	0	0	0	0,5	0,5	Time (s)	Error (%)
# 1	0,2446	0,0009	0,0030	0,0023	0,0003	0,0015	0,7045	0,4851	2622	1,6358
# 2	0,2378	0,0033	0,0099	0,0059	0,0060	0,0095	0,3734	0,4685	2557	3,7595
# 3	0,2443	0,0032	0,0012	0,0010	0,0019	0,0058	0,8864	0,4818	2560	2,0511
# 4	0,2439	0,0004	0,0038	0,0025	0,0014	0,0015	0,6673	0,4838	2556	1,8038
# 5	0,2460	0,0005	0,0004	0,0009	0,0024	0,0019	0,3378	0,4861	2560	1,4846
# 6	0,2419	0,0043	0,0002	0,0048	0,0054	0,0007	0,5121	0,4830	2562	2,0585
# 7	0,2443	0,0024	0,0012	0,0003	0,0010	0,0075	0,9905	0,4829	2571	2,0068
# 8	0,2445	0,0001	0,0010	0,0100	0,0003	0,0135	0,6144	0,4889	2568	2,1000
# 9	0,2456	0,0038	0,0001	0,0024	0,0002	0,0053	0,0766	0,4838	2719	1,8319
# 10	0,2418	0,0014	0,0034	0,0081	0,0024	0,0064	0,5147	0,4829	3055	2,2004

TABLE II. MEAN ERROR AND AVERAGE TIME OF OPTIMIZATION ALGORITHMS

	Friction fault		Backlash		Short-circuit		Eccentricity		Gain		Total	
	Mean Error (%)	Time (s)	Mean Error (%)	Time (s)	Mean Error (%)	Time (s)	Mean Error (%)	Time (s)	Mean Error (%)	Time (s)	Mean Error (%)	Time (s)
GA low fault	2,093	2633	1,678	2336	5,042	1644	3,323	2502	1,928	2492	2,813	2.322
GA high fault	4,491	2501	2,247	2524	6,253	2559	1,778	2453	0,950	2527	3,144	2.513
PSO low fault	0,930	1662	0,294	1242	0,863	2152	1,013	2099	0,452	1395	0,711	1.710
PSO high fault	2,773	1875	1,629	1634	2,734	1474	1,465	1506	0,205	1078	1,761	1.513

This definition of  $Err\%$  is equivalent to a mean square error, where the contribution of the element  $k_7$  is weighted by the reference value of  $\hat{k}_6$ , since the progressive rotor static eccentricity fault is represented in polar coordinates with modulus  $\zeta = k_6$  and phase  $\phi = 2\pi k_7 - \pi$ .

Table II summarizes the performances of the GA and PSO optimizations in terms of average error and computational time. All calculations have been parallelized over the two processors of an Intel Core i5-6200U CPU (2.3GHz) running Windows 10 Pro and Matlab r2016a.

Figures 4 and 5 show, respectively, the average error and computational time, sorted by fault mode and optimization algorithm. The PSO algorithm appears to be superior to GA optimizations in both computational time and fault estimation error. In fact, PSO usually requires fewer evaluations of the objective function than GA for the same convergence rate; this result is consistent with [27].

For both algorithms, the average error for high-fault combinations is greater than for low combination fault. This behavior can likely be ascribed to the discrepancy between the reference and monitor model, which grows nonlinearly with the fault vector.

The CPU time required by the fault detection is not significantly dependent on the fault mode; however, a noticeably worse accuracy is obtained for short circuit faults, in particular with GA optimizations.

The cause can be found either in the significant difference in the algorithm exploited by the two models for the computation of these progressive faults or in the similarity between the effects of this fault and the proportional gain drift.

To ultimately discern the cause of this inconsistent behavior, a deeper statistical analysis is needed and will be performed in a future work.

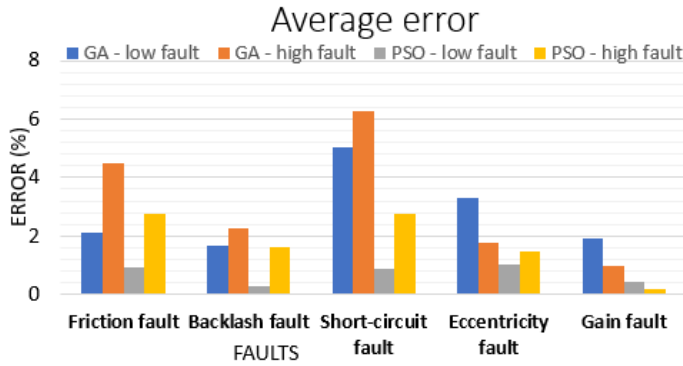

Figure 4. Average error of the two employed optimization algorithms.

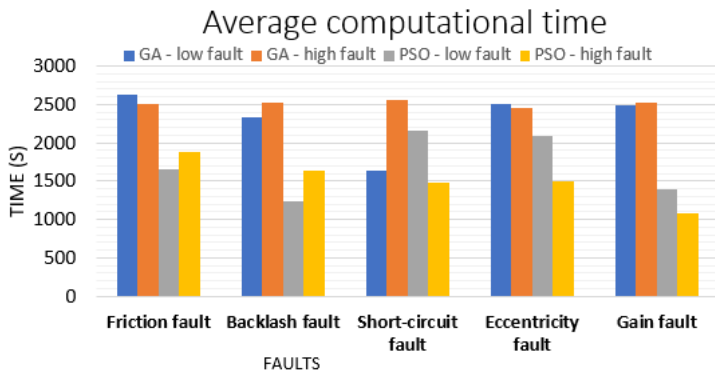

Figure 5. Average computational time of the two algorithms performed.

### VIII. CONCLUSIONS AND FUTURE PERSPECTIVES

An optimization problem and two different types of resolution algorithms have been discussed. Both algorithms are calibrated to perform at best for a given benchmark problem. The results show that the PSO algorithm outperforms GA in our application, both in terms of precision and computational time. As proven by Wolpert and Macready [28], an optimization algorithm that is suitable for one problem, can provide rough solutions for another. In particular, they state that if in a problem an algorithm works better than a random search, then on some class of problem it will perform worse than random search. It is part of the engineering task to find an optimization algorithm suitable and acceptably performing for a given problem. Future research on this topic will be focused on the implementation of other types of optimization algorithms, as differential evolution (DE) or alternative swarm intelligence [29]. In addition, a deeper statistical analysis is needed to verify the inconsistent behavior of the two algorithms with certain fault modes. The algorithms will be assessed for multiple faults, in order to test a wider applicability of these methods.

### ACKNOWLEDGMENT

The authors wish to thank Prof. Lorenzo Borello and Prof. Paolo Maggiore for their essential support in the conception and development of this research activity.

### REFERENCES

- [1] J. A. Rosero, J. A. Ortega, E. Aldabas and L. Romeral, "Moving Towards a More Electric Aircraft," *EEE Aerospace and Electronic Systems Magazine*, vol. 22, n. 3, pp. 3–9, April 2017.
- [2] M. Howse, "All-electric aircraft," *Power Engineer*, 4 35-37 (2003)
- [3] R.E.J. Quigley, "More Electric Aircraft," *Proc. Eighth Annual Applied Power Electronics Conference*, 906-911 (1993)
- [4] G. Vachtsevanos, F. Lewis, M. Roemer, A. Hess, and B. W, "Intelligent Fault Diagnosis and Prognosis for Engineering Systems", John Wiley & Sons, Inc., 2006.
- [5] Z. Williams, "Benefits of IVHM: an analytical approach," 2006 IEEE Aerospace Conference, 2006, pp. 9 pp.–.
- [6] Benedettini, O., Baines, T. S., Lightfoot, H.W., and Greenough, R. M., "State-of-the-art in integrated vehicle health management," *Proceedings of the Institution of Mechanical Engineers, Part G: Journal of Aerospace Engineering*, vol. 223, no. 2, 2009, pp.157–170.
- [7] J. H. Holland, "Genetic algorithms and the optimal allocation of trials," *SIAM Journal on Computing*, vol. 2, n. 2, pp. 88–105, 1973.
- [8] J. Kennedy and R. Eberhart, "Particle Swarm Optimization," *Proc. IEEE International Conf. on Neural Networks* (Perth, Australia), IEEE Service Centre, Piscataway, NJ, 1995.
- [9] P. C. Berri, M. D. L. Dalla Vedova and P. Maggiore, "A smart electromechanical actuator monitor for new model-based prognostic algorithms," *International Journal of Mechanics and Control*, vol. 17, n. 02, December 2016.
- [10] P. C. Berri, M. D. L. Dalla Vedova and P. Maggiore, "On-board electromechanical servomechanisms affected by progressive faults: proposal of a smart GA model-based prognostic approach," *Proc. ESREL 2017 - 27<sup>th</sup> European Safety and Reliability Conference*, Portoroz, Slovenia, pp. 839–845, June 2017.
- [11] M.D.L. Dalla Vedova, A. Germanà and P. Maggiore, "Proposal of a model-based fault identification genetic technique for more-electric aircraft flight control EM actuators," *Proc. of the Third European Conference of the Prognostics and Health Management Society 2016*, Bilbao, Spain, pp. 555-564, 5-8 July 2016.
- [12] M.D.L. Dalla Vedova, P. Maggiore, L. Pace and A. Desando, "Evaluation of the Correlation Coefficient as a Prognostic Indicator for Electromechanical Servomechanism Failures," *International Journal of Prognostics and Health Management*, vol. 6, n. 1, 2015. ISSN: 2153-2648.
- [13] M. D. L. Dalla Vedova, P. Maggiore, P. C. Berri, "Enhanced hybrid prognostic approach applied to aircraft on-board electromechanical actuators affected by progressive faults," *Proc. ESREL 2018 - 28<sup>th</sup> European Safety and Reliability Conference*, Trondheim, Norway, June 2018.
- [14] T. Kenjo and S. Nagamori, *Brushless Motors: Advanced Theory and Modern Applications*. Sogo Electronics Press, Tokyo, Japan, 3rd edition; 2003
- [15] J. C. Chesley. *Handbook of Reliability Prediction Procedures for Mechanical Equipment*. USA Navy, Naval Surface Warfare Center, NSWC Carderock Division, 2011
- [16] J. Weiss, "Control Actuation Reliability and Redundancy for Long Duration, Underwater Vehicle Missions with High Value Payloads," *Proc. 2014 Underwater Intervention Conference (UI 2014)*, New Orleans, Louisiana, USA. 2014.
- [17] L. Borello and M. D. L. Dalla Vedova, "A dry friction model and robust computational algorithm for reversible or irreversible motion transmission," *International Journal of Mechanics and Control*, vol. 13, n. 2, pp. 37–48, December 2012.
- [18] L. Borello, G. Villero and M. D. L. Dalla Vedova, "New asymmetry monitoring techniques: effects on attitude control," *Aerospace Science and Technology*, vol. 13, n. 8, pp. 475–487, 2009.
- [19] L. Borello and M. D. L. Dalla Vedova, "Flaps Failure and Aircraft Controllability: Developments in Asymmetry Monitoring Techniques," *Journal of Mechanical Science and Technology (JMST)*, vol. 28, n. 11, pp. 4593–4603, 2014.

- [20] S. Binitha and S. Siva Sathya, "A survey of Bio inspired Optimization Algorithms," *Int. Journal of Soft Computing and Engineering (IJSCE)*, vol. 2, n. 2, May 2012.
- [21] E. Bonabeau, M. Dorigo and G. Theraulaz, *Swarm Intelligence: From Natural to Artificial Systems*. Oxford University Press, p. 7, 1999.
- [22] M. Rigamonti et al., "Ensemble of optimized echo state networks for remaining useful life prediction," *Neurocomputing*, 2017.
- [23] M. A. Lones, "Metaheuristics in Nature-Inspired Algorithms," *Proc. Genetic and Evolutionary Computation Conference (GECCO'14)*, Vancouver, July 2014, doi: 10.1145/2598394.2609841.
- [24] F. Jian, J-C Marè and F. Yongling, "Modelling and simulation of flight control electromechanical actuators with special focus on model architecting, multidisciplinary effects and power flows," *Chinese Journal of Aeronautics (CJA)*, CSAA, November 2016.
- [25] Y. Padmaraja, "Brushless DC (BLDC) motor fundamentals," *Application Note AN885*, Microchip Technology Inc., 2003.
- [26] I. Markovsky, S. Van Huffel, "Overview of total least-squares methods" *J. of Signal Processing* 10 2283–2302 (2007)
- [27] R. Hassan, B. Cohanin, O. de Weck, and G. Venter, "A Comparison of Particle Swarm Optimization and the Genetic Algorithm," 46th AIAA/ASME/ASCE/AHS/ASC Structures, Structural Dynamics and Materials Conference, Apr. 2005.
- [28] D. H. Wolpert and W. G. Macready, "No Free Lunch Theorems for Optimization," *IEEE Transactions on Evolutionary Computation*, vol. 1, n. 1, pp. 67-82, April 1997.
- [29] A. El Hadi S., D. Zuomin and K. Meysam, "A comparative study on recently-introduced nature-based global optimization methods in complex mechanical system design," *MDPI Algorithms*, vol. 10, n. 4, art. 120, 2017, doi: 10.3390/a10040120.

#### AUTHORS' BACKGROUND

Your Name	Title*	Research Field	Personal website
Matteo Davide Lorenzo DALLA VEDOVA	Assistant professor	Aeronautical Systems Engineering, Design, Analysis and Numerical Simulation of On-Board Systems, Study of Secondary Flight Control Systems and Conception of Related Monitoring Strategies, Development of Prognostic Algorithms for Aerospace Servomechanism, Study of Innovative Primary Flight Control Architecture	<a href="http://www.dimeas.polito.it/en/personale/scheda/(nominativo)/matteo.dallavedova">http://www.dimeas.polito.it/en/personale/scheda/(nominativo)/matteo.dallavedova</a>
Pier Carlo BERRI	PhD Student	Development of Prognostic Algorithms for Aerospace Servomechanism	<a href="http://www.dimeas.polito.it/en/personale/scheda/(nominativo)/pier.berri">http://www.dimeas.polito.it/en/personale/scheda/(nominativo)/pier.berri</a>
Stefano RE	Master student	Development of Prognostic Algorithms for Aerospace Servomechanism	

\*This form helps us to understand your paper better, the form itself will not be published.

\*Title can be chosen from: master student, PhD candidate, assistant professor, lecturer, senior lecturer, associate professor, full professor