

Model-Based Prognostic Methods Applied to Physical Dynamic Systems

Original

Model-Based Prognostic Methods Applied to Physical Dynamic Systems / Dalla Vedova, Matteo D. L.. - In: INTERNATIONAL JOURNAL OF MATHEMATICAL AND COMPUTATIONAL METHODS. - ISSN 2367-895X. - ELETTRONICO. - 3:(2018), pp. 28-36.

Availability:

This version is available at: 11583/2729974 since: 2019-04-04T11:12:45Z

Publisher:

IARAS

Published

DOI:

Terms of use:

This article is made available under terms and conditions as specified in the corresponding bibliographic description in the repository

Publisher copyright

(Article begins on next page)

Model-Based Prognostic Methods Applied to Physical Dynamic Systems

MATTEO D. L. DALLA VEDOVA

Department of Mechanical and Aerospace Engineering (DIMEAS)

Politecnico di Torino

Corso Duca degli Abruzzi, 24 - 10129 – Torino

ITALY

matteo.dallavedova@polito.it

Abstract: - In several engineering fields, especially in the recent years, the development of adequate diagnostic/prognostic methodologies able to provide a timely and reliable evaluation of the health status of a given system has become a strategic task in order to guarantee suitable levels of reliability, robustness and logistic availability. In particular, at this moment are in the spotlight some prognostic approaches that, on the basis of some representative parameters (measured directly or indirectly), are able to evaluate the health status of a physical system with a suitable (and quantifiable) level of accuracy and robustness; it must be noted that, especially in recent years, these methods are increasingly meeting interest and application in many technical fields and, nowadays, they represent an important task in various scientific disciplines. If considered failures are characterized to progressive evolutions, the health status of a given dynamic system (e.g. environmental, mechatronic, structural, etc.) and the related failure modes can be identified and quantified by means of different approaches widely described in the literature. In the last ten years more and more researchers studied and proposed new strategies aimed to design prognostic algorithms able to identify precursors of the progressive failures affecting a system: in fact, when a degradation pattern is correctly identified, it is possible to trigger an early warning and, if necessary, activate corrective actions (i.e. proper remedial or maintenance tasks, replacement of the damaged components, etc.). Typically these methods are strictly technology-oriented: they can result extremely effective for some specific applications whereas may fail for other purposes and technologies; therefore, it is necessary to "design" and calibrate the prognostic algorithm as a function of the considered problem, taking into account several parameters such as the given (dynamic) system, the available sensors (physical or virtual), the considered progressive failures and the related boundary conditions. This work proposes an overview of the most common model-based diagnostic/prognostic strategies (derived from aerospace systems field), putting in evidence their applicability, strengths and eventual shortcomings.

Key-Words: - Model-Based Approach, PHM, Prognostics/Diagnostic Algorithms, Physical Dynamic Systems

1 Introduction

The study of complex physical dynamic systems (e.g. environmental, thermochemical, mechanical, electronic, mechatronic) disposes nowadays of several tools able to recognize their peculiarities, identify their characteristic parameters, study their evolution and highlight, in a timely manner, abnormal or undesired conditions. In particular, combining together numerical modeling and simulation techniques with methods of signal analysis and evaluation of the characteristic parameters, it is possible to develop new analysis and monitoring tools, based on the comparison between the real (physical) system and the corresponding numerical model (e.g. a numerical algorithm, representing a simplified description of the real phenomena, that is assumed as the reference of the real one and operating as a monitor).

This approach, commonly defined as "model-based", is widely used in engineering disciplines, but can also find effective applications in many other technical-scientific fields. Indeed, especially in the recent years, the development of adequate diagnostic/prognostic (D/P) methodologies able to provide a timely and reliable evaluation of the system health status has become a strategic task to guarantee suitable levels of reliability, robustness and logistic availability. In general, the main goal of diagnostics is the identification of nature and causes of a certain (undesired) phenomenon affecting the monitored system. Diagnostics is applied in many different disciplines with variations in the use of logic, analytics, and experience to determine "cause and effect"; in systems engineering and computer science, it is typically used to determine the causes of symptoms, generate mitigation actions, and provide active solutions [1].

The prognostics approach has been originally developed in engineering fields: in these contexts, its main purpose of this discipline, formally named Prognostics and Health Management (PHM) [2], is to provide real-time data of the current status of the system and to calculate the Remaining Useful Life (RUL) [3] before a fault occurs with the consequence that a component becomes unable to perform its functionalities at the desired level. For instance, referring to aeronautical onboard application field, the advantage of implementing PHM clearly emerges from the comparison with classical monitoring and maintenance concepts, based on overhaul or life-limited parts (e.g. primary flight controls are a critical part of the aircraft system and are therefore designed with a conservative safe-life approach, which imposes to replace the related components after having endured a fixed amount of flight hours or operating cycles; as reported in [4], by applying PHM strategies failures could be managed in a more effective way, reducing risks and criticalities and gathering several benefits in terms of costs, effectiveness and efficiency). It must be noticed that the said diagnostic and prognostic concepts, because of the variety of applications and the huge impact that they generate, have aroused great interest in the scientific and technological world and, especially in recent years, have been the subject of extensive development and dissemination in the scientific literature. Very often these contributions, despite being extremely innovative and significant, result too theoretical or specific and tend to overlook a more comprehensive approach (system engineering vision), dwelling on well-defined and circumscribed aspects of the considered problem [4].

The benefits deriving from the application of the prognostics to the system engineering (applied to industrial, mechanical or aerospace fields) could have a positive impact on many other technological domains, producing beneficial effects on safety and maintenance issues (e.g. reducing risks of unexpected system conditions, maintenance costs and inspection time). Then, wanting to extend these concepts from aeronautical system engineering to different technical disciplines, in a more general sense the main purpose of the prognostic is to predict when a particular system/component degrades, losing some of its functionality (e.g. being unable to meet the desired performances). It is fundamentally based on the comprehension and analysis of given set of possible failure modes and on the capability of individuating the related initial symptoms of aging or wear.

Once properly gathered and organized, these databases can be effectively used as an input of a proper failure propagation model. In particular, at this moment are in the spotlight D/P approaches that, based on given representative parameters (measured directly or indirectly), are able to evaluate the health status of a physical system with a suitable (and quantifiable) level of accuracy and robustness; it must be noted that, especially in recent years, these methods are increasingly meeting interest and application in many technical fields and nowadays is an important task in various scientific disciplines. In accordance with the aforesaid considerations, this work proposes a critical comparison between several diagnostic/prognostic model-based strategies (derived from onboard system field), putting in evidence their applicability, strengths and eventual shortcomings. In order to compare the different approaches, highlighting the main criticalities and evaluating their performance, author will refer to a test case derived from aeronautical systems that, although relating to a very specific application, allows evaluating the different methods in a clearer and a more applicative way.

2 D/P Model-Based Methods

The health status of a given dynamic system (e.g. environmental, mechatronic, structural, etc.) and the eventual incipient failures that concern it, especially if related to progressive evolutions, can be identified and quantified by means of different approaches. It must be noted that, particularly in last decade, there has been a strong impulse in the development of strategies aimed to design prognostic algorithms able to identify precursors of the progressive damages/faults affecting a system: indeed, if it is correctly identified the degradation pattern, it is possible to perform a Fault Detection and Identification (FDI) [5], i.e. identify the unexpected/undesired effects and quantify their magnitudes, and an early warning can be triggered, leading to proper corrective actions (i.e. proper remedial or maintenance tasks, corrective actions to reduce the harmful effects of certain events, phenomena or activities, replacement of the damaged components, etc.). In literature, many different FDI methods have been investigated: model-based techniques based on the direct comparison between the output of real and monitoring system [2, 6-8], on the spectral analysis of well-defined system behaviors performed by Fast Fourier Transform (FFT) [9-10], on combinations of these methods [11] or on Artificial Neural Networks (ANN) [12-15].

Since these algorithms are strictly technology-oriented, they can show great effectiveness for some specific applications, while they may fail for other applications and technologies: therefore, it is necessary to properly conceive the specific D/P method as a function of several parameters such as the given (dynamic) system, the available sensors (physical or virtual), the considered progressive failures and the related boundary conditions.

Then it is necessary to carefully analyze the considered system in order to identify the fundamental relationships that characterize its dynamics and, therefore, to formulate a numerical model capable of simulating its dynamic behavior. This model can be implemented in different ways, e.g. mathematical model obtained from its physical relationships, simplified best-fitting models, cause-effect relationships, identification methods, sets of experimental data or empirical relations, approaches hybrids obtained by combining the previous ones. In this phase, it is necessary to evaluate the effects due to the considered faults/anomalous conditions on the system response, in order to identify the eventual precursors of failures [5] and to define proper test cases suitable to perform the FDI analysis [8, 10].

It should be noted that this model must be appropriately tested and validated in order to verify its fidelity and robustness and, especially if designed for monitoring or FDI activities, it is necessary to verify its ability to accurately simulate the behavior of the system in the presence of the aforementioned failure modes. The so obtained monitoring model (MM), sensitive to the considered failures and to any significant boundary conditions [16], can be used to estimate the health status of the system on the base of different approaches that will be briefly described in the following.

3 Fault Maps Method

A first method for estimating the health status of a system, particularly effective when the faults considered are few and they are relatively independent of each other, is that based on the so-called "fault maps" (FMs) [8, 10]. A FM constitutes the graphical representation of how a system-representative parameter varies as a function of different types of faults. In other words, if the measurement of the real system parameter is available, this instrument allows supposing which extent a certain couple of faults has on the actuator. More exactly, a fault map displays the first fault G_1 on x-axis and the representative parameter P_1 (i.e. a systems characteristic assumed as failure precursor) on y-axis. Each map represents a set of curves $P_1 = f(G_1)$ that is parameterized with the second fault G_2 . A proper choice of P_1 is crucial in order to obtain a useful fault map. In the first place, this parameter should be a function of both G_1 and G_2 and be highly sensitive to changes in fault levels. In particular, its dependence from the two kinds of fault should be monotonic, i.e. the curves plotted on the maps should not intersect. The last feature is the most important, since it allows detecting a specific area on the map containing all the possible fault levels. However, the proposed method, in order to identify the system conditions with high enough accuracy, requires more than one of these maps for a specific couple of faults. It must be noted that, when several maps are employed, they have to be independent from each other: in this way, the parameter represented on each map is a magnitude that is not related to the others. By using three independent maps, i.e. representing three different parameters P_1, P_2 and P_3 , an accurate area containing the possible faults is identified (Fig. 1).

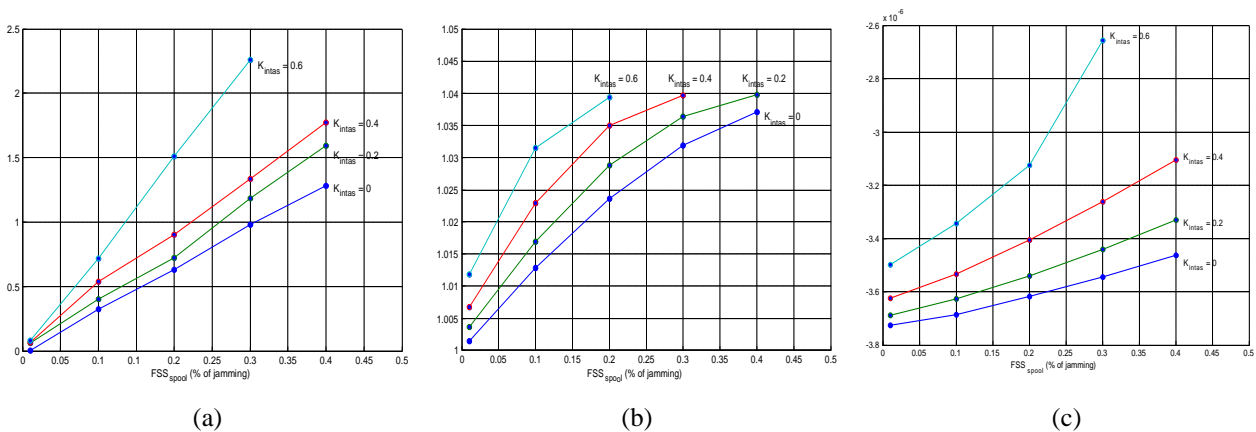

Fig. 1: Example of FMs referring to the example shown in [10]: these maps report the evolution of the three failure precursors P1, P2 and P3, calculated, respectively, for different values of the progressive faults (FSS_{spool} and K_{intas}).

This FDI method is relatively simple, relatively inexpensive for the processor and fast enough (because, typically, requests reduced CPU time), but needs a rather complex and time-consuming preparation phase in which it is necessary to define the FMs by comparing, for various combinations of faults, the responses of the real system with those of the corresponding MM. In fact, in order to calculate the above FMs, it is necessary to acquire the responses of the physical system for different combinations of faults and then, comparing them with the corresponding response of the MM, in order to calculate the relative fault precursors.

It is clear that this “experimental-like” data acquisition can be rather expensive, both in economic and in chronological terms; furthermore, compared to other methods, this approach does not allow for a very detailed FDI but rather a relatively coarse classification of faults.

4 Evolutionary Algorithms

Several optimization techniques are commonly used also for model parameter estimation tasks, which can be classified into two main categories: deterministic (direct or indirect) and probabilistic (stochastic, as the Monte Carlo method, simulated annealing and genetic algorithms). As reported in [10], a large part of these methods are local minima search algorithms and often do not find the global solution (i.e. they are highly dependent on a good initial setting). Local-minima approaches would not be robust and may provide a false indication of parameter changes in an on-line system (i.e. a wrong selection of starting settings could determinate problems of convergence or global minima). Otherwise, global search methods, such as genetic algorithms (GA) and simulated annealing (SA), provide more promising options for on-line model identification [6-7]. Starting from these, it is possible to develop model-based (M-B) FDI methods, able to identify fault levels of a given system, analyzing its dynamic response and comparing it, through a process of optimization, with the response generated from a corresponding numerical model. Then, the proposed approach to detect these faults is based on the comparison of two signals provided respectively from the reference system (RS) and the monitor (MM). It should be noted that the latter is a simplified model (consistent with the detailed one) with the requirement to be simple and suitably fast (both in terms of implementation and computational time), since these methods needs several iterations, making the heavily detailed model inappropriate to the purpose.

The comparison between the reference system (RS) and the monitoring model (MM) is performed by an optimization algorithms that aim to minimize proper fitness functions [17], e.g. a quadratic error function, by changing iteratively one or more parameters (defined as representative of the examined faults) of the monitor model until the output signal best overlaps with the reference system response. If these parameters, calculated by the optimization algorithm, match with the real ones, the method has worked properly; if the monitor model is accurate enough, the optimization algorithm gives a good detection of the system health. Operationally speaking, the parameters so obtained (relative to the MM) can then be correlated to the corresponding progressive failure (affecting the RS) in order to perform the aforementioned FDI. The optimization process is usually governed by means of Genetic Algorithms (e.g. see [17]) or other evolutionary systems such as Simulated Annealing [18-21], MS-ABC [22], Cuckoo Search [23], Firefly Algorithm [24], etc. In this paragraph, to clarify the different methods, the author will now refer to GA [25] and SA [26].

4.1 Simulated Annealing

The SA method originates, as the name suggests, from the study of thermal properties of solids. Indeed, this procedure [18-19], was then an exact copy of the physical process which could be used to simulate a collection of atoms in thermodynamic equilibrium at a given temperature. As reported in the literature [20-21], there is a significant correlation between the terminology of the thermodynamic annealing process (the behavior of systems with many degrees of freedom in thermal equilibrium at a finite temperature value) and combinatorial optimization finding the global minimum of a given function based on many parameters. As reported in [27], the aforesaid association between the thermodynamic simulation and the combinatorial optimization reported in Table 1 can be more clearly explained by noting that the cost of a solution represents the corresponding objective function value (i.e. the function that the aforesaid optimization algorithm attempts to minimize in order to identify the optimal solution), the neighbor solution is a new system solution calculated by the optimization algorithm and evaluate, with respect to the previous one, using the said cost functions, and the control parameter is the system parameter iteratively modified by the optimization process so as to minimize its objective function, as shown in literature by [28-29].

Table 1. Association between thermodynamic simulation and SA combinatorial optimization.

Thermodynamic Annealing	Combinatorial Optimization
System State	Feasible Solutions
Energy of a State	Cost of Solution
Change of state	Neighbor solution
Temperature	Control parameter
Minimum Energy	Minimum Cost

Figure 2 shows the operating logic scheme of the Simulated Annealing optimization method.

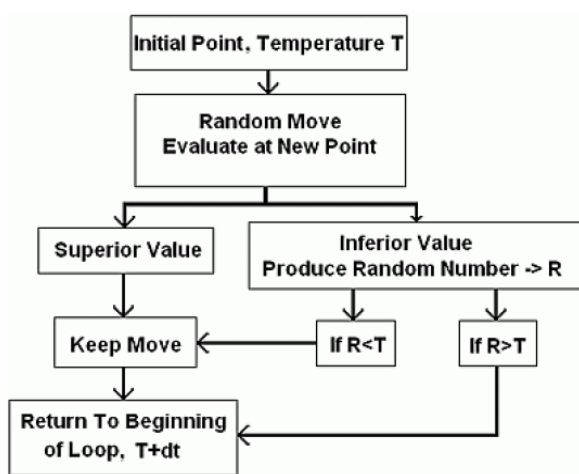

Fig. 2: Operating Logic of SA Method [30-31].

Operatively speaking the SA optimization method operates as follows: at a given temperature and energy (i.e. the cost of the solution), a new nearby solution $i+1$ is generated (at each iteration) as a random displacement from the current solution i ; the energy of the resulting new solution is then computed and the energetic difference ΔE is determined with respect to preceding energy as:

$$\Delta E = E_{i+1} - E_i \tag{1}$$

The acceptance probability of the new solution is:

$$P(\Delta E) = \begin{cases} e^{-\Delta E/(k_b T)} & \text{if } \Delta E > 0 \\ 1 & \text{if } \Delta E < 0 \end{cases} \tag{2}$$

This means that, if the new nearby solution has a lower energy level (successful iteration), the transition is accepted. Otherwise (unsuccessful iteration), a uniformly distributed random number r more or equal than 0 and less than 1 is drawn and the step will only be accepted in the simulation if it is less or equal the Boltzmann probability factor, i.e. $r \leq P(\Delta E)$.

After a certain number of steps at the same temperature T , the latter is decreased following the specified cooling schedule scheme. It is worth noticing that the temperature does not take part directly to the optimization itself, but it acts merely as an exploration parameter. As at high temperatures T the factor $P(\Delta E)$ is very close to 1, most likely many up-hill steps are accepted, even if they are unsuccessful. In this way, a wide exploration of the search space can be performed (this is the main feature of this algorithm). Subsequently, as the temperature falls off, the search is confined in a more limited space since Boltzmann factor $P(\Delta E)$ collapses to very low values, thus decreasing the acceptance probability in case of $\Delta E > 0$ (the algorithm becomes more selective). Finally, the global optimum should be found as soon as the temperature reaches its minimum value but, in practice, reannealing is performed, raising the temperature after a certain number of new points have been accepted so that the search starts again at the higher temperature. Basically, it avoids being caught in local minima. It must be noted that, with respect to Genetic Algorithms, Simulated Annealing methods are more effective at finding the global minima, but at the cost of a larger amount of iterations [2, 26].

4.2 Genetic Algorithms

As previously mentioned, the optimization process used to achieve the said FDI could be performed by means of a GA approach. It must be noted that GAs are a class of evolutionary algorithms that take inspiration to the natural selection process. GAs have been used in science and engineering as adaptive algorithms for solving practical problems and as computational models of natural evolutionary systems [32]. About that, it must also be noted that, especially in order to implement a model-based FDI algorithm able to perform the health diagnosis of a real EMA evaluating several variables (typically five or more), the method based upon GAs are usually more effective and reliable with respect to other approaches (e.g. deterministic methods). In recent years the applications of genetic algorithms in the development of diagnostic systems based on numerical models have found wide interest in the scientific world and have led to several technical applications. For example, in the fields of mechatronics and electromechanical systems, much research has been published on new diagnostic and prognostic algorithms integrating GA optimization and M-B approach [7].

Optimization starts with a population of points (called chromosomes) which together represent the human genome. Each chromosome is a potential solution of the problem, the so called fitness function (i.e. the error function), calculated for each of them. According to the obtained value, a rank is assigned to them: since it is a minimization, chromosomes who give lower fitness values have a better rank and are selected to be the parents of a new population of points (the following generation) created by means of different operators called crossover (a combination of parents), migration and mutation. This process, widely described in [17], is repeated iteratively until the last child of the last generation fulfills a stopping criterion, that can be a tolerance on the fitness function, a limit on the stall generations, a maximum number of generations, etc. By tuning these settings, the method can be more or less fast or may or not converge to a final solution.

It is important to consider that there is a strong dependence on the particular problem taken into account. GAs are generally suitable for parameters estimation since both single and multiple faults give accurate results for different levels of damage; furthermore, they are able to manage several parameters and, by making use of appropriate numerical devices (e.g. by parallelizing the calculation on different processors, adoption of appropriately simplified numerical models, implementation of the whole algorithm on low-level codes), it is possible to considerably reduce the calculation times making them compatible with the common maintenance procedures. However, since GAs can suffer from local minimum problems (i.e. they are not always able to identify the corresponding global minima), it is necessary to properly design and calibrate the algorithm [25].

5 Test Case

In order to compare the different M-B FDI approaches, it is considered a test case derived from aeronautical systems; in fact, even if related to a very specific application, this example can be useful to evaluate the different methods in a clearer and more applicative way. For this reason, the author evaluated the effectiveness of the aforementioned prognostic method on an electromechanical actuator (EMA) typically employed in modern aircraft flight control systems, according to “More Electric Aircraft” paradigm [34] and “All Electric Aircraft” paradigm [35]. As shown in Fig. 3, a typical EMA for flight controls can be schematically divided into the following main subsystems:

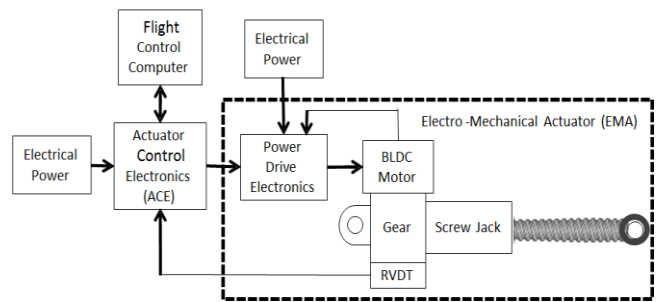

Fig. 3: Electromechanical Actuator Scheme [33].

1. an actuator control electronics (ACE) that closes the feedback loop, by comparing the commanded position (FBW) with the actual one, elaborates the corrective actions and generates the reference current (I_{ref});
2. a Power Drive Electronics (PDE) that regulates the three-phase electrical power;
3. an electrical motor, often BLDC (BrushLess Direct Current) type;
4. a gear reducer having the function to decrease the motor angular speed (RPM) and increase its torque to desired values;
5. a system that transforms rotary motion into linear motion: ball or roller screws are usually preferred to acme screws because, having a higher efficiency, they can perform the conversion with lower friction;
6. a network of sensors used to close the feedback loops (current, angular speed and position) that control the whole actuation system.

As previously said, for this study two numerical models of the EMA were developed: they have been implemented in MATLAB/Simulink® environment.

A very detailed reference model (representing the RS) is used as a virtual test rig for the FDI algorithm, simulating the behavior of the faulty physical system. Given that the computing time required by this model, however, is not compatible with the use in the FDI algorithm itself, a simplified monitor model (i.e. the MM) was built to achieve a light computing cost and, at the same time, a high accuracy in reproducing the early effects of different incipient fault modes. The reference model (RS), widely described in [33], contains a detailed simulation of the physical phenomena acting in the EMA, in particular regarding the EM stator-rotor coupling [36-39], end-of-travels, compliance and backlashes acting on the mechanical transmission [40-41], dry friction acting on bearings, gears, hinges and screw actuators [42] and a precise model of the behavior of the power electronics, including the solid-state inverter and the PWM control of the three electrical phases.

The monitor model (MM) is a simplified representation of the system using, for example, an equivalent single-phase DC motor with a single feedback loop instead of the more complex electromagnetic (EM) model of the BLDC. This requires the introduction of a shape function based model for the simulation of the electrical fault, which is not strictly related to the physics of the system, but allows reproducing the effects of faults with good accuracy [16]. The above models have been used to evaluate the performances of the different FDI methods in the case of combined progressive failures: results for the three methods considered in the present work (FMs, SA and GAs) are respectively reported in [8], [33] and [17].

6 Conclusion

In this work the author considered three Model-Based (M-B) Fault Detection/Identification (FDI) methods applied to physical dynamic systems, introducing briefly their main characteristics, strengths, shortcomings and providing some bibliographic reference useful to understand these approaches or evaluate their performances. As previously reported, the Failure Maps (FMs) method is relatively simple, not expensive for the processor and fast enough (reduced CPU time), but requires a rather complex and expensive preparation phase for identifying the aforesaid maps; however, being based on a deterministic type algorithm, this method is exempt from the criticalities typical of heuristic methods. Operatively speaking, it must be noted that the so obtained FDI results typically rather coarse (as a consequence of the discretization introduced parametrizing the FMs curves), are able to handle only a few parameters (generally no more than two or three progressive failures) and their performances are markedly dependent on the uncertainties and errors that characterize the mapping process. Vice versa, the Simulated Annealing (SA) results trustworthy also for combined failures and it is possible to assess its validity even on other possible different conditions (i.e. different combinations of progressive faults and boundary conditions). With respect to other optimization algorithms that are highly dependent on good initial settings, SA-based algorithms are usually able to perform the optimization process reaching the corresponding global minimum independently by the starting settings. However, especially when it is necessary to manage an optimization process on many parameters, the SA shows its limits with respect to genetic algorithms, resulting less fast and effective.

As regards genetic algorithms, they are usually effective and reliable in the FDI of failures precursors; in particular, GAs are particularly suitable for parameters estimation since both single and multiple faults give accurate results for different levels of damage. Compared to FMs and SA methods, the GA approach is certainly more performing and promising for FDI applications but, as already explained in the previous paragraph, it is necessary to appropriately design the algorithm to avoid (or, at least, appropriately limit) the risk of false positive and incorrect/omitted identifications. In conclusion, it should be noted that, although referred to an onboard application, the author already tested the three methods (FM, GA and SA) by means of a numerical test-bench simulating a typical electromechanical actuator for primary flight controls; several progressive failures have been evaluated and, as reported in [8, 11, 16, 33], the three FDI prognostic methods (albeit with different performances, calculation times and levels of accuracy) provided encouraging results.

Acknowledgment

In conclusion, the author would like to sincerely thank Prof. Lorenzo Borello, Prof. Paolo Maggiore, Dr. Alfio Germanà and Dr. Pier Carlo Berri for their support for the development of this work.

References:

- [1] W. R. Simpson and J. W. Sheppard, *System Test and Diagnosis*, Kluwer Academic Publishers, Boston, 1994.
- [2] C. S. Byington, W. Watson, D. Edwards and P. Stoelting, A Model-Based Approach to Prognostics and Health Management for Flight Control Actuators, *IEEE Aerospace Conference Proceedings*, USA, 2004.
- [3] G. Vachtsevanos, F. Lewis, M. Roemer, A. Hess and B. Wu, *Intelligent Fault Diagnosis and Prognosis for Engineering Systems*, Wiley, 2006.
- [4] M. Battipede, M. D. L. Dalla Vedova, P. Maggiore and S. Romeo, Model based analysis of precursors of electromechanical servomechanisms failures using an artificial neural network, *AIAA Modeling and Simulation Technologies Conference*, Kissimmee, 2015.
- [5] L. Borello, M. D. L. Dalla Vedova, G. Jacazio and M. Sorli, A Prognostic Model for Electrohydraulic Servovalves, *Annual Conference of the Prognostics and Health Management Society PHM 2009*, San Diego, CA, 2009.

- [6] A. Raie and V. Rashtchi, Using a genetic algorithm for detection and magnitude determination of turn faults in an induction motor, *Electrical Engineering*, Vol.84, 2002.
- [7] M. Alamyal, S. M. Gadoue and B. Zahawi, Detection of induction machine winding faults using genetic algorithm. Diagnostics for Electric Machines, *Power Electronics and Drives 9th IEEE Int.Symposium*, Valencia (Spain), 2013, pp. 157-161.
- [8] M. D. L. Dalla Vedova, P. Maggiore, L. Pace and A. Desando, Evaluation of the correlation coefficient as a prognostic indicator for electromechanical servomechanism failures, *International Journal of Prognostics and Health Management*, Vol.6, 2015.
- [9] M. S. Mamis, M. Arkan and C. Keles, Transmission lines fault location using transient signal spectrum, *International Journal of Electrical Power & Energy Systems*, Vol.53, 2013, pp. 714-718.
- [10] M. D. L. Dalla Vedova, P. Maggiore and L. Pace, Proposal of prognostic parametric method applied to an electrohydraulic servomechanism affected by multiple failures, *WSEAS Transactions on Environment and Development*, Vol.10, 2014, pp. 478-490.
- [11] M. D. L. Dalla Vedova, G. Jacazio, P. Maggiore, M. Sorli, Identification of precursors of servovalves failures for implementation of an effective prognostics, *Int. Conference of Recent Advances in Aerospace Actuation Systems and Components*, 2010, pp. 116-126.
- [12] S. S. Refaat, H. Abu-Rub, M. S. Saad, E. M. Aboul-Zahab and A. Iqbal, ANN-based for detection, diagnosis the bearing fault for three phase induction motors using current signal, *IEEE International Conference on Industrial Technology (ICIT)*, 2013, pp. 253-258.
- [13] H. Su and K. T. Chong, Induction machine condition monitoring using neural network modelling, *IEEE Transactions on Industrial Electronics*, Vol.54, No.1, 2007, pp. 241-249.
- [14] S. Hamdani, O. Touhami, R. Ibtouen and M. Fadel, Neural network technique for induction motor rotor faults classification-dynamic eccentricity and broken bar faults, *IEEE International Symposium on Diagnostics for Electric Machines, Power Electronics & Drives*, 2011, pp. 626-631.
- [15] M. D. L. Dalla Vedova, D. De Fano and P. Maggiore, Neural network design for incipient failure detection on aircraft EM actuator, *International Journal of Mechanics and Control*, Vol.17, No.1, 2016, pp. 77-83.
- [16] P. C. Berri, M. D. L. Dalla Vedova, P. Maggiore, A smart electromechanical actuator monitor for new model-based prognostic algorithms, *International Journal of Mechanics and Control*, Vol.17, No.2, 2016, pp. 19-25.
- [17] P. C. Berri, M. D. L. Dalla Vedova and P. Maggiore, On-board electromechanical servomechanisms affected by progressive faults: proposal of a smart GA model-based prognostic approach, *27th European Safety and Reliability Conference*, 2017, pp. 839-845.
- [18] N. Metropolis, A. N. Rosenbluth, M. N. Rosenbluth, A. H. Teller and E. Teller, Equations of State Calculations by Fast Computing Machines, *Journal of Chemical Physics*, Vol.21, No.6, 1953, pp. 1087-1092.
- [19] V. Miranda, D. Srinivasan and L. Proenca, Evolutionary computation in powersystems, *Int. Journal of Electr. Power Energy Syst.*, Vol.20, No.2, 1998, pp. 89-98.
- [20] S. Kirkpatrick, C. D. Gelatt and M. P. Vecchi, Optimization by Simulated Annealing, *Science*, Vol.220, 1983, pp. 671-680.
- [21] R. H. J. M. Otten and L. P. P. P. Van Ginneken, *The Annealing Algorithm*, Kluwer Academic Publishers, Boston, 1989.
- [22] M. Subotic and M. Tuba, Parallelized Multiple Swarm Artificial Bee Colony Algorithm (MS-ABC) for Global Optimization, *Studies in Informatics and Control*, Vol.23, No.1, 2014.
- [23] M. Tuba, M. Subotic and N. Stanarevic, Modified cuckoo search algorithm for unconstrained optimization problems, *ECC'11 Proc. of the 5th European Conference on European Computing Conference*, Paris, France, 2011, pp. 263-268.
- [24] M. Subotic, M. Tuba and N. Stanarevic, Parallelization of the firefly algorithm for unconstrained optimization problems, *Latest Advances in Information Science and Applications*, Vol.22, No.3, 2012, pp. 264-269.
- [25] M. Pirlot, General Local Search Methods, *European Journal of Operational Research*, Vol.92, 1996, pp. 493-511.
- [26] T. Jing, C. Morillo and M. G. Pecht, Rolling element bearing fault diagnosis using simulated annealing optimized spectral kurtosis, *IEEE Conference on Prognostics and Health Management (PHM)*, 2013.
- [27] K. K. Vishwakarma, H. M. Dubey, M. Pandit and B. K. Panigrahi, Simulated annealing approach for solving economic load dispatch problems with valve point loading effects, *International Journal of Engineering, Science and Technology*, Vol.4, No.4, 2012, pp. 60-72.

- [28] A. Sadegheih, Evolutionary Algorithms and Simulated Annealing in the Topological Configuration of the Spanning Tree, *WSEAS Transactions on Systems*, Vol.7, No.2, 2008.
- [29] C. R. Yu and Y. Luo, An Improved Nested Partitions Algorithm Based on Simulated Annealing in Complex Decision Problem Optimization, *WSEAS Transactions on Computers*, Vol.7, No.3, 2008, pp. 75-82.
- [30] M. D. L. Dalla Vedova, P. Maggiore and L. Pace, A New Prognostic Method Based on Simulated Annealing Algorithm to Deal with the Effects of Dry Friction on Electro mechanical Actuators, *International Journal of Mechanics*, Vol.9, 2015, pp. 236-245.
- [31] M. D. L. Dalla Vedova, D. Lauria, P. Maggiore and L. Pace, Electromechanical actuators affected by multiple failures: A simulated-annealing-based fault identification algorithm, *International Journal of Mechanics*, Vol.10, 2016, pp. 219-226.
- [32] M. Mitchell, *An introduction to genetic algorithms*, MIT Press, Cambridge, 1996.
- [33] M. D. L. Dalla Vedova, A. Germanà and P. Maggiore, Proposal of a new simulated annealing model-based fault identification technique applied to flight control EM actuators, *Risk, Reliability and Safety: Innovating Theory and Practice: Proceedings of ESREL 2016*, Glasgow, 2016, pp. 313-321.
- [34] R. E. J. Quigley, More electric aircraft, *Proc. of the Eighth Annual IEEE Applied Power Electronics Conference - APEC '93*, San Diego, CA, 1993, pp. 906-911.
- [35] M. Howse, All-electric aircraft, *Power Engineer*, Vol.17, No.4, 2003.
- [36] T.A. Haskew, D.E. Schinstock and E. Waldrep, Two-Phase On' Drive Operation in a Permanent Magnet Synchronous Machine Electromechanical Actuator, *IEEE Transactions on Energy Conversion*, Vol.14, 1999.
- [37] B. K. Lee and M. Ehsani, Advanced Simulation Model for Brushless DC Motor Drives, *Electric Power Components and Systems*, Vol.31, No.9, 2003, pp. 841-868.
- [38] A. HalvaeiNiasar, H. Moghbelli and A. Vahedi, Modelling, Simulation and Implementation of Four-Switch Brushless DC Motor Drive Based On Switching Functions, *IEEE EUROCON 2009*, 18-23 May, St. Petersburg, Russia, 2009.
- [39] M. Çunkas and O. Aydoğdu, Realization of Fuzzy Logic Controlled Brushless DC Motor Drives using Matlab/Simulink, *Mathematical and Computational Applications*, Vol.15, No.02, 2010, pp. 218-229.
- [40] L. Borello, G. Villero and M. D. L. Dalla Vedova, New asymmetry monitoring techniques: effects on attitude control, *Aerospace Science and Technology*, Vol.13, No.8, 2009, pp. 475-487.
- [41] L. Borello and M. D. L. Dalla Vedova, Flaps Failure and Aircraft Controllability: Developments in Asymmetry Monitoring Techniques, *Journal of Mechanical Science and Technology (JMST)*, Vol.28, No.11, 2014, pp. 4593-4603.
- [42] L. Borello and M. D. L. Dalla Vedova, A dry friction model and robust computational algorithm for reversible or irreversible motion transmission, *International Journal of Mechanics and Control*, Vol.13, No.2, 2012, pp. 37-48.