



POLITECNICO DI TORINO
Repository ISTITUZIONALE

Dispositivo tastatore, marker per dispositivo tastatore e sistema di misura per effettuare misure fotogrammetriche di oggetti di grandi dimensioni (Feeler device, marker for a feeler)

Original

Dispositivo tastatore, marker per dispositivo tastatore e sistema di misura per effettuare misure fotogrammetriche di oggetti di grandi dimensioni (Feeler device, marker for a feeler device and system for taking photogrammetric measurements of objects) / Franceschini, Fiorenzo; Galetto, Maurizio; Maisano, DOMENICO AUGUSTO FRANCESCO; Mastrogiacomo, Luca; Bai, Ou. - (2016).

Availability:

This version is available at: 11583/2729213 since: 2019-03-22T12:55:08Z

Publisher:

Published

DOI:

Terms of use:

openAccess

This article is made available under terms and conditions as specified in the corresponding bibliographic description in the repository

Publisher copyright

(Article begins on next page)



Ministero dello Sviluppo Economico

Direzione generale per la lotta alla contraffazione

Ufficio Italiano Brevetti e Marchi

ATTESTATO DI BREVETTO PER INVENZIONE INDUSTRIALE

Il presente brevetto viene concesso per l'invenzione oggetto della domanda:

N. 102016000001556

TITOLARE/I: • POLITECNICO DI TORINO

Fassio Valeria

DOMICILIO: Metroconsult S.r.l.
via Sestriere 100
10060 None

INVENTORE/I: • FRANCESCHINI Fiorenzo
• GALETTO Maurizio
• MAISANO Domenico Augusto
• MASTROGIACOMO Luca
• BAI Ou

TITOLO: Dispositivo tastatore, marker per dispositivo tastatore e sistema di misura per effettuare misure fotogrammetriche di oggetti di grandi dimensioni

CLASSIFICA: G01C

DATA DEPOSITO: 11/01/2016

Roma, 27/06/2018

Il Dirigente della Divisione
Loredana Guglielmetti



Ministero dello Sviluppo Economico

Ricevuta di presentazione

per

Brevetto per invenzione industriale



Domanda numero: 102016000001556

Data di presentazione: 11/01/2016

DATI IDENTIFICATIVI DEL DEPOSITO

Ruolo	Mandatario
Data di compilazione	11/01/2016
Titolo	Dispositivo tastatore, marker per dispositivo tastatore e sistema di misura per effettuare misure fotogrammetriche di oggetti di grandi dimensioni
Carattere domanda	Ordinaria
Esenzione	NO
Accessibilità al pubblico	NO
Numero rivendicazioni	8
Autorità depositaria	

RICHIEDENTE/I

Natura giuridica	Persona giuridica
Denominazione	POLITECNICO DI TORINO
Partita IVA	00518460019
Nazione sede legale	Italia
Tipo Società	le universita'
Quota percentuale	100.0%

DOMICILIO ELETTIVO

Cognome/R.sociale	Metroconsult S.r.l.
Indirizzo	via Sestriere 100
CAP	10060
Comune	None

Telefono	011 - 9904174
Fax	011 - 9904182
Indirizzo Email	metroc@xero.it
Riferimento depositante	PLT026

MANDATARI/RAPPRESENTANTI

Cognome	Nome
Baroni	Matteo
Borsano	Corrado
Camolese	Marco
Ferroni	Filippo
Reposio	Giancarlo
Zelioli	Giovanni
Fassio	Valeria

INVENTORI

Cognome	Nome	Nazione residenza
FRANCESCHINI	Fiorenzo	Italia
GALETTO	Maurizio	Italia
MAISANO	Domenico Augusto	Italia
MASTROGIACOMO	Luca	Italia
BAI	Ou	Italia

CLASSIFICAZIONI

Sezione	Classe	Sottoclasse	Gruppo	Sottogruppo
---------	--------	-------------	--------	-------------

NUMERO DOMANDE COLLEGATE

DOCUMENTAZIONE ALLEGATA

Tipo documento	Riserva	Documento
Rivendicazioni	NO	PLT026 testo rivendicazioni.pdf.p7m hash: 01e359f143cf7d5da6871ebabf5bb5b5
Descrizione in italiano*	NO	PLT026 testo descrizione.pdf.p7m hash: 1a7b758ccd49bf5d77bad4b23c1ac938
Disegni provvisori	NO	Disegni provvisori.pdf.p7m hash: a52e044a9198a3dc3ff30c8fe3567975
Riassunto	NO	PLT026 testo riassunto.pdf.p7m hash: 5b148b9645cf56cfc3b7c288398c4a17
Rivendicazioni in inglese	SI	hash:
Disegni	SI	hash:
Lettera di Incarico	SI	hash:
Disegni	SI	hash:

PAGAMENTI

Tipo	Identificativo	Data
Bollo	01130514860321	21/02/2015

ESENZIONI INDICATE

Esenzione su diritti e tasse	DM 02/04/2007 - art. 2: esonero dal pagamento dei diritti di deposito e di trascrizione relativamente ai brevetti per invenzioni industriali, e modelli di utilita' a vantaggio di: Universita'; Amministrazioni Pubbliche aventi fra i loro scopi istituzionali finalita' di ricerca; Amministrazioni della Difesa; Amministrazioni delle Politiche Agricole, alimentari e forestali.
------------------------------	--



- (51) International Patent Classification:
G01C 11/02 (2006.01) G01B 5/012 (2006.01)
G01C 11/08 (2006.01) G01B 11/00 (2006.01)
- (21) International Application Number: PCT/IB2017/050089
- (22) International Filing Date: 9 January 2017 (09.01.2017)
- (25) Filing Language: Italian
- (26) Publication Language: English
- (30) Priority Data:
102016000001556 11 January 2016 (11.01.2016) IT
- (71) Applicant: **POLITECNICO DI TORINO** [IT/IT]; Corso Duca Degli Abruzzi 24, 10129 Torino (to) (IT).
- (72) Inventors: **FRANCESCHINI, Fiorenzo**; Via Moncalvo, 27, 10023 Chieri (to) (IT). **GALETTO, Maurizio**; Via Torino, 16, 10040 La Cassa (TO) (IT). **MAISANO, Domenico Augusto**; Corso Einaudi, 55, 10129 Torino (to) (IT). **MASTROGIACOMO, Luca**; Via Thaon di Revel, 11, 10090 San Raffaele Cimena (TO) (IT). **BAL, Ou**; Via Francesco Morosini, 8, 10128 Torino (to) (IT).

- (74) Agents: **CAMOLESE, Marco** et al.; c/o METROCONSULT SRL, VIA SESTRIERE 100, 10060 None (to) (IT).
- (81) Designated States (unless otherwise indicated, for every kind of national protection available): AE, AG, AL, AM, AO, AT, AU, AZ, BA, BB, BG, BH, BN, BR, BW, BY, BZ, CA, CH, CL, CN, CO, CR, CU, CZ, DE, DJ, DK, DM, DO, DZ, EC, EE, EG, ES, FI, GB, GD, GE, GH, GM, GT, HN, HR, HU, ID, IL, IN, IR, IS, JP, KE, KG, KH, KN, KP, KR, KW, KZ, LA, LC, LK, LR, LS, LU, LY, MA, MD, ME, MG, MK, MN, MW, MX, MY, MZ, NA, NG, NI, NO, NZ, OM, PA, PE, PG, PH, PL, PT, QA, RO, RS, RU, RW, SA, SC, SD, SE, SG, SK, SL, SM, ST, SV, SY, TH, TJ, TM, TN, TR, TT, TZ, UA, UG, US, UZ, VC, VN, ZA, ZM, ZW.
- (84) Designated States (unless otherwise indicated, for every kind of regional protection available): ARIPO (BW, GH, GM, KE, LR, LS, MW, MZ, NA, RW, SD, SL, ST, SZ, TZ, UG, ZM, ZW), Eurasian (AM, AZ, BY, KG, KZ, RU, TJ, TM), European (AL, AT, BE, BG, CH, CY, CZ, DE, DK, EE, ES, FI, FR, GB, GR, HR, HU, IE, IS, IT, LT, LU, LV, MC, MK, MT, NL, NO, PL, PT, RO, RS, SE, SI, SK, SM, TR), OAPI (BF, BJ, CF, CG, CI, CM, GA, GN, GQ, GW, KM, ML, MR, NE, SN, TD, TG).

[Continued on next page]

(54) Title: FEELER DEVICE, MARKER FOR A FEELER DEVICE AND SYSTEM FOR TAKING PHOTOGRAMMETRIC MEASUREMENTS OF OBJECTS

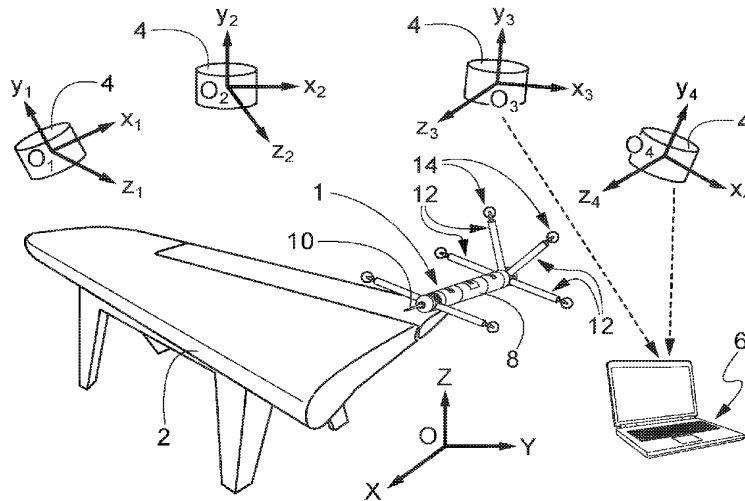

Fig. 1

(57) Abstract: Feeler device for photogrammetric measurements, comprising a main body for holding it; a tip connected to the main body and adapted to come in contact with the external surface of an object to be measured; a plurality of spokes adapted to support respective spherical markers internally lit by respective light sources.



Published:

— with international search report (Art. 21(3))

— before the expiration of the time limit for amending the claims and to be republished in the event of receipt of amendments (Rule 48.2(h))

FEELER DEVICE, MARKER FOR A FEELER DEVICE AND SYSTEM FOR TAKING PHOTOGRAMMETRIC MEASUREMENTS OF OBJECTS**DESCRIPTION**

The present invention relates to the field of coordinate measurements in the three-dimensional (3D) space to be taken on large objects (ranging from one meter to a few tens of meters in size) by using photogrammetric techniques.

In particular, the invention relates to a feeler device for photogrammetric measurements, which can provide, with a high degree of accuracy, the three-dimensional coordinates of points touched by the feeler on the surface of an object being measured, by using as a reference a photogrammetric system consisting of high-resolution digital cameras with high depth of field. The invention further concerns a marker for such a feeler device and a measurement system for taking photogrammetric measurements, which allows obtaining accurate measurements on the object to be analyzed.

Optical measurement systems for quality dimensional checks in industrial environments are becoming increasingly widespread for in-line verifications of the dimensions and tolerances of mass-produced items and for occasional or periodic inspections and tests on finished products.

In recent years, digital photogrammetry has played a predominant role amongst the most common technologies for measuring large objects (such as, for example, aircraft fuselages and wings, ship hulls, bodies of railway and road vehicles, large tanks or industrial structures, aerospace modules, etc.).

The physical principles on which this technology is based make use of the triangulation concept, according to which by framing a point in the three-dimensional space through at least two video cameras, the position coordinates thereof can be obtained from the acquired images. This operation, which has been known since the beginning of the last century, has now become much easier and faster because of the appearance of digital video cameras and supercomputers.

In the metrologic field, the systems that were first used for taking precision measurements on large objects employed markers that were integral with the object to be measured, particularly flat markers (stickers applied to the object) or spherical markers fixed to the object. In both cases, these were passive markers that needed to be illuminated by an external

light source to become visible to the video cameras.

The video cameras acquired images of the object and of the markers positioned thereon, and the position of such markers was reconstructed by using triangulation techniques.

5 It was thus possible to compute the dimensions and geometry of the object being measured starting from the positions of the various markers.

The main drawbacks of such systems were related to the difficulty in handling and properly positioning the markers on the object, in addition to the fact that they always required an external light source.

Systems have recently been introduced which consist of:

- 10 - a “constellation” of high-resolution video cameras positioned in the measurement space around the object to be measured;
- a feeler, with a set of markers positioned thereon: by applying photogrammetric principles to the acquired images, and knowing the intrinsic geometry of the feeler itself, it is possible to determine the spatial coordinates of the feeler tip as it moves on the surface of the object
- 15 being measured, thereby allowing the computation of the overall dimensions of the object;
- a processing unit, to which the data of the images acquired by the various video cameras are sent, for synchronizing the system and processing the data.

A fundamental element of this type of system is the feeler.

Feelers of two types are currently available:

- 20 - the first type comprises feelers equipped with passive markers, i.e. flat optical references (generally consisting of target-shaped stickers or reflective balls), which, in order to be detected by the video cameras, need to be illuminated by suitable lights integral with the system of video cameras;
- the second type includes feelers equipped with flat active feelers, which do not require
- 25 external illumination because they are *per se* luminous.

The most important problems suffered by the feelers currently available are related to the fact that passive markers always require the use of an external illumination system, whereas in the case of active markers the object to be measured cannot be framed in full round by the video cameras because such markers are flat.

30 This makes it difficult to measure objects that, because of their shape, cannot be easily illuminated or viewed thoroughly.

In addition, the solutions currently available do not allow for measurement corrections or

refinements taking into account kinematic variations or environmental condition changes occurring during the measurement.

It is therefore one object of the present invention to provide a feeler device for photogrammetric measurements which allows taking effective measurements on objects of any shape, which is independent of external light sources, and which allows taking accurate
5 measurements even when kinematic variations or environmental changes occur during the measurement.

It is a further object of the present invention to provide a marker for a feeler device and a measurement system for taking photogrammetric measurements on large objects.

10 Some embodiments of the present invention relate to a feeler device that overcomes the drawbacks of the prior art.

In one embodiment of the invention, the feeler device for photogrammetric measurements comprises a main body for holding it, a tip connected to the main body and adapted to come in contact with the external surface of an object to be measured, and a plurality of spokes
15 adapted to support respective spherical markers internally lit by respective light sources.

In another embodiment of the invention, the main body houses a plurality of kinematic and environmental sensors.

In another embodiment of the invention, the main body houses an antenna for wireless communication with a remote processing unit.

20 In another embodiment of the invention, the spherical markers are made from translucent polymeric material for omnidirectional diffusion of the light generated by the light sources.

In another embodiment of the invention, the tip is made from ultra-rigid stainless steel, with the terminal part consisting of synthetic ruby.

In another embodiment of the invention, the marker for a feeler device for taking
25 photogrammetric measurements comprises a sphere of translucent polymeric material for omnidirectional diffusion of the light generated by a light source contained therein.

In another embodiment of the invention, the system for taking photogrammetric measurements on a large object comprises a feeler device having a main body for holding it, a tip connected to the main body and adapted to come in contact with the external surface of
30 an object to be measured, and a plurality of spokes adapted to support respective spherical markers internally lit by respective light sources. The system further comprises a plurality of video cameras adapted to acquire images of the feeler device and a remote processing unit

adapted to receive the images from the video cameras and to process them in order to determine the position of the tip as it moves on the external surface of the object to be measured, so as to compute the overall dimensions of the object.

In another embodiment of the invention, the video cameras are oriented in respective Cartesian systems (x_n, y_n, z_n) relative to a general reference system (X, Y, Z) .

Further features and advantages of the invention will become apparent in the light of the following detailed description, provided by way of non-limiting example with reference to the annexed drawings, wherein:

- Figure 1 is a perspective view of a feeler device according to the present invention and an associated object to be measured;

- Figure 2 is a perspective view of the feeler device of Fig. 1.

In brief, the feeler device according to the present invention is equipped with specific three-dimensional “active” markers having a spherical shape, which do not need any specific external light sources and which can be framed by the video cameras of the measurement system from every angle.

The feeler device is also equipped with a set of kinematic and/or environmental sensors (e.g. accelerometers, temperature sensors, brightness sensors, etc.) which allow improving, enriching and/or refining the obtained measurements by correcting and compensating the measurement results according to external influential parameters.

Figure 1 shows a perspective view of a measurement system for taking photogrammetric measurements according to the present invention.

The measurement system comprises a feeler device 1, an associated object 2 to be measured, a plurality of video cameras 4, and a remote processing unit 6, e.g. a laptop computer.

The video cameras 4 are oriented in respective Cartesian systems x_n, y_n, z_n relative to a general reference system X, Y, Z . The video cameras 4 are adapted to acquire images of the feeler device 1.

The processing unit 6 is adapted to receive the acquired images from the video cameras 4 and to process them in order to determine the position of the feeler device 1 relative to the object 2.

The feeler device 1 comprises a main body 8 for holding it, a tip 10 connected to the main body 8 and adapted to come in contact with the external surface of the object 2 to be measured, a plurality of spokes 12 adapted to support respective spherical markers 14

internally lit by light sources, preferably infrared (or visible-spectrum) LEDs.

Advantageously, the main body 8 is adapted to accommodate batteries for supplying power to the spherical active markers 14.

In a preferred variant of the invention, the main body 8 houses a plurality of kinematic and
5 environmental sensors (e.g. accelerometer, temperature sensor, humidity sensor, etc.), an antenna for wireless communication with the processing unit 6, and a button for measurement acquisition. All these devices are powered by batteries housed in the main body 8.

Through the antenna, the feeler device 1 communicates to the processing unit 6 operation
10 data that will allow the processing unit 6 to diagnose possible faults in the feeler device 1.

On the basis of the images coming from the video cameras 4, the processing unit 6 is also adapted to determine, by using triangulation techniques known to those skilled in the art, the position of the tip 10 as it moves along the external surface of the object 2 to be measured, and then to compute, by using *per se* known techniques, the overall dimensions of the object
15 2.

Every component of the feeler 1 is provided with internal wires with quick-coupling connectors at their ends for the power connection. Such connectors (designated as 50 in Figure 2) will allow the components to be easily interchanged for the purpose of customizing the configuration of the feeler 1 in order to adapt it to specific measurement requirements.

20 The markers 14 are made from translucent polymeric material for omnidirectional diffusion of the light generated by the internal LEDs.

The tip 10 is made from ultra-rigid stainless steel, with the terminal part consisting of synthetic ruby.

The main body 8, the spokes 12 and the connectors 50 are made from composite material,
25 preferably carbon fiber or the like.

The feeler device 1 of the present invention overcomes the problems highlighted in the analysis of the prior art, thus speeding up and improving the effectiveness of the entire measurement system.

The feeler device 1 is “modular” because its physical structure can be changed by adding or
30 removing elements (markers, sensors, contact tip, etc.) as necessary in accordance with the purposes of the measurement. The modularity of the feeler proposed herein allows structuring the most appropriate geometry depending on the characteristics of the object 2

that needs to be measured, so that even deep undercuts can be reached or shadow areas can be avoided where the video cameras 4 would otherwise not be able to frame the feeler 1.

The feeler 1 is “self-powered” by a suitable set of batteries, and is connected in wireless mode to the measurement system (video cameras 4 and control unit 6 for data processing).

5 The spherical markers 14 are self-lit by the LEDs included therein, which allow full round diffusion of the light due to the material they are made of and to the specific finishing thereof (glazing). Moreover, the spherical markers 14 are visible in full round to the different video cameras 4 of the system because of their three-dimensionality, which considerably reduces the complexity of use of the feeler 1, since it does not need to take a specific orientation
10 towards the video cameras 4 during the measurement operations. In addition, the shadow areas where the feeler 1 is not visible to the video cameras are significantly reduced.

The measurement system is modular because it is made up of a number of components that can be assembled in different configurations according to the measurement needs (number of video cameras 4, coverage of the measurement space, shape of the object to be measured,
15 presence of undercuts, etc.).

The feeler device 1 is equipped with kinematic, orientation and environmental sensors for correcting the measurement values according to the measurement conditions, leading to higher quality of the readings obtained; furthermore, it is constantly in communication, via the wireless connection, with the processing unit 6, which can diagnose in real time its
20 operating condition and efficiency.

The most important advantages of the device of the present invention are the following:

- due to full round visibility of the markers 14, the markers 14 can be seen by the video cameras 4 from all angles;
- due to the modularity and full round visibility of the markers 14, the feeler 1 can be adapted
25 to different geometries of the measurement space, of the object 2 to be measured, and of the layout of the video cameras 4;
- the presence of additional sensors allows constant monitoring of the operating condition and effectiveness/efficacy of the unit. It also allows correcting the measurement results according to the environmental and operating conditions in which the measurement is being
30 carried out;
- the wireless connection to the central processing unit 6 allows continuous exchange of information between the two elements for the purpose of optimizing the measurement;

- no external lighting system is required, thus considerably reducing the overall dimensions and complexity (also as concerns the power supply) of the whole system, as well as the costs thereof;

5 - since no external illumination is required (which, for energetic reasons, would necessarily require a fixed wiring), it is possible to use independent video cameras 4 with wireless power supply and wireless connection to the central processing unit 6 for data exchange and synchronization;

- the modularity and the wireless connection of the feeler 1 and video cameras 4 ensure better flexibility of use of the measurement system as a whole.

10 Given its specific metrologic and operational characteristics, the feeler 1 proposed herein is particularly suited to all those contexts in which dimension and tolerance verifications have to be carried out on large objects.

The main fields of application are:

- Aircraft industry (measurements on fuselages, wing sections or surfaces, etc.);

15 - Aerospace industry (geometric characterization of aerospace modules);

- Shipbuilding industry (measurement on ship hulls);

- Railway industry (measurements on bodies of means of rail transport);

- Automotive and road transport industry (body dimension check);

20 - Construction of large technological structures (turbines, wind turbines, tanks, telescope reflectors, etc.).

Of course, without prejudice to the principle of the invention, the forms of embodiment and the implementation details may be extensively varied from those described and illustrated herein by way of non-limiting example, without however departing from the protection scope of the present invention as set out in the appended claims.

25

CLAIMS

1. Feeler device (1) for photogrammetric measurements, comprising:
- a main body (8) for holding it;
 - a tip (10) connected to the main body (8) and adapted to come in contact with the external surface of an object to be measured (2);
- 5 - a plurality of spokes (12) adapted to support respective spherical markers (14) internally lit by respective light sources.
2. Device according to claim 1, wherein the main body (8) houses a plurality of kinematic and environmental sensors.
3. Device according to claim 1 or 2, wherein the main body (8) houses an antenna for
- 10 wireless communication with a remote processing unit (6).
4. Device according to any one of the preceding claims, wherein the spherical markers (14) are made from translucent polymeric material for omnidirectional diffusion of the light generated by the light sources.
5. Device according to any one of the preceding claims, wherein the tip (10) is made from
- 15 ultra-rigid stainless steel, with the terminal part consisting of synthetic ruby.
6. Marker (14) for a feeler device for photogrammetric measurements, comprising a sphere of translucent polymeric material for omnidirectional diffusion of the light generated by a light source contained therein.
7. System for taking photogrammetric measurements on a large object (2), comprising:
- 20 - a feeler device (1) according to any one of claims 1 to 5;
- a plurality of video cameras (4) adapted to acquire images of the feeler device (1);
 - a remote processing unit (6) adapted to receive the images from the video cameras (4) and to process them for the purpose of determining the position of the tip (10) as the latter moves on the external surface of the object to be measured (2), so as to compute the overall
- 25 dimensions of the object (2).
8. System according to claim 7, wherein the video cameras (4) are oriented in respective Cartesian systems (x_n, y_n, z_n) relative to a general reference system (X, Y, Z) .

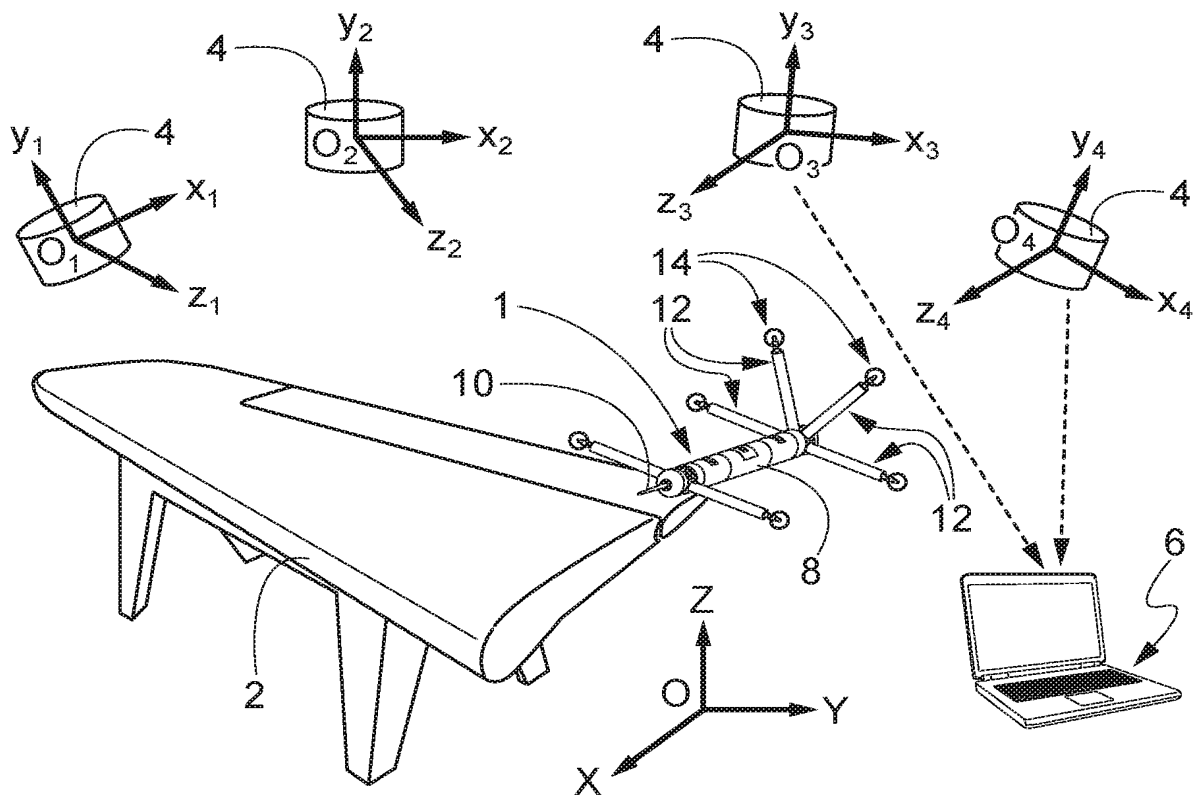

Fig. 1

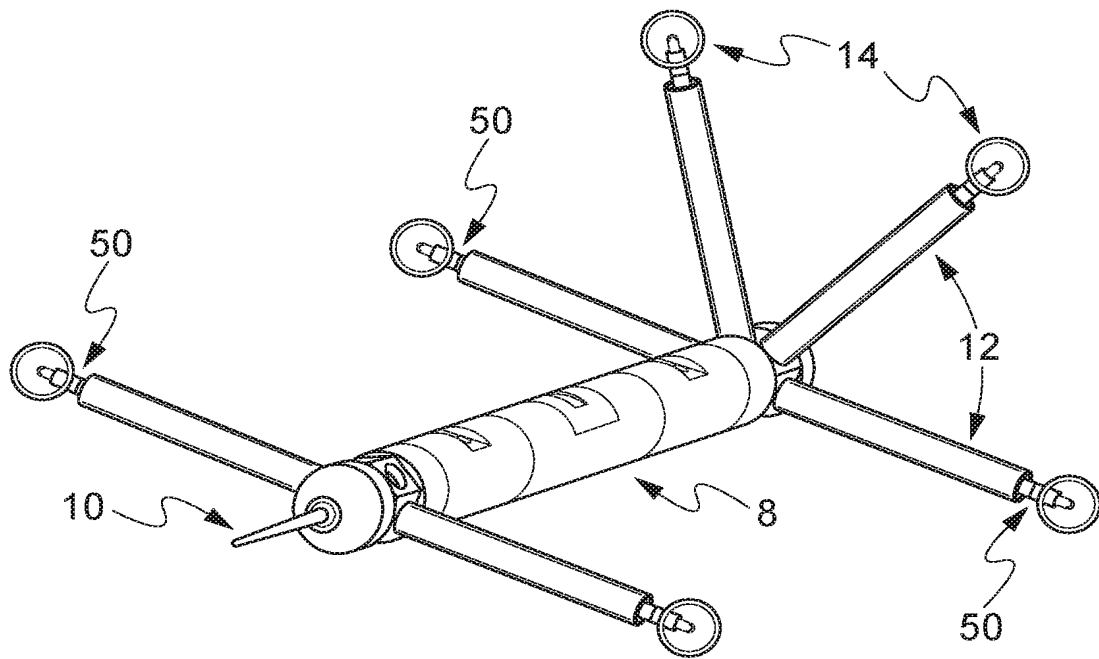

Fig. 2

INTERNATIONAL SEARCH REPORT

International application No PCT/IB2017/050089

A. CLASSIFICATION OF SUBJECT MATTER
 INV. G01C11/02 G01C11/08 G01B5/012 G01B11/00
 ADD.

According to International Patent Classification (IPC) or to both national classification and IPC

B. FIELDS SEARCHED

Minimum documentation searched (classification system followed by classification symbols)
 G01C G01B

Documentation searched other than minimum documentation to the extent that such documents are included in the fields searched

Electronic data base consulted during the international search (name of data base and, where practicable, search terms used)

EPO-Internal, WPI Data

C. DOCUMENTS CONSIDERED TO BE RELEVANT

Category*	Citation of document, with indication, where appropriate, of the relevant passages	Relevant to claim No.
X	US 2005/000102 A1 (CHRISTOPH RALF [DE] ET AL) 6 January 2005 (2005-01-06) paragraphs [0012], [0013], [0017] - [0020], [0027], [0028], [0031], [0087], [0098], [0104] - [0107]; figure 11 ----- -/--	1-5,7,8



Further documents are listed in the continuation of Box C.



See patent family annex.

* Special categories of cited documents :

"A" document defining the general state of the art which is not considered to be of particular relevance

"E" earlier application or patent but published on or after the international filing date

"L" document which may throw doubts on priority claim(s) or which is cited to establish the publication date of another citation or other special reason (as specified)

"O" document referring to an oral disclosure, use, exhibition or other means

"P" document published prior to the international filing date but later than the priority date claimed

"T" later document published after the international filing date or priority date and not in conflict with the application but cited to understand the principle or theory underlying the invention

"X" document of particular relevance; the claimed invention cannot be considered novel or cannot be considered to involve an inventive step when the document is taken alone

"Y" document of particular relevance; the claimed invention cannot be considered to involve an inventive step when the document is combined with one or more other such documents, such combination being obvious to a person skilled in the art

"&" document member of the same patent family

Date of the actual completion of the international search

6 June 2017

Date of mailing of the international search report

13/06/2017

Name and mailing address of the ISA/

European Patent Office, P.B. 5818 Patentlaan 2
 NL - 2280 HV Rijswijk
 Tel. (+31-70) 340-2040,
 Fax: (+31-70) 340-3016

Authorized officer

Rocca, Simone

INTERNATIONAL SEARCH REPORT

International application No

PCT/IB2017/050089

C(Continuation). DOCUMENTS CONSIDERED TO BE RELEVANT

Category*	Citation of document, with indication, where appropriate, of the relevant passages	Relevant to claim No.
X	<p>Smarter Home Life: "Review: Cree 4Flow 60 Watt Equivalent Soft White LED Light Bulb",</p> <p>23 November 2014 (2014-11-23), page 1, XP054976764, Retrieved from the Internet: URL:https://www.youtube.com/watch?v=ic47BLkfJYU [retrieved on 2016-09-05] the whole document from min. 2:25 to 2:50</p> <p style="text-align: center;">-----</p>	6
A	<p>US 6 611 141 B1 (SCHULZ WALDEAN A [US] ET AL) 26 August 2003 (2003-08-26) column 2, line 64 - column 3, line 19; figure 1</p> <p style="text-align: center;">-----</p>	1-8
A	<p>US 5 440 392 A (PETTERSEN ALF [NO] ET AL) 8 August 1995 (1995-08-08) the whole document</p> <p style="text-align: center;">-----</p>	1-8
A	<p>WO 2008/113147 A2 (EMBRAER AERONAUTICA SA [BR]; MADUREIRA ANDERSON LUIZ [BR]) 25 September 2008 (2008-09-25) the whole document</p> <p style="text-align: center;">-----</p>	1-8

INTERNATIONAL SEARCH REPORT

Information on patent family members

International application No

PCT/IB2017/050089

Patent document cited in search report	Publication date	Publication date	Patent family member(s)	Publication date
US 2005000102	A1	06-01-2005	AT 211815 T	15-01-2002
			AU 8336698 A	30-12-1998
			DE 19880875 D2	13-07-2000
			DE 29823884 U1	24-02-2000
			EP 0988505 A1	29-03-2000
			JP 4122069 B2	23-07-2008
			JP 2002503339 A	29-01-2002
			US 6651351 B1	25-11-2003
			US 2005000102 A1	06-01-2005
			WO 9857121 A1	17-12-1998

US 6611141	B1	26-08-2003	AU 2204200 A	31-07-2000
			CA 2356271 A1	06-07-2000
			EP 1153292 A1	14-11-2001
			JP 4612194 B2	12-01-2011
			JP 2002533721 A	08-10-2002
			US 6611141 B1	26-08-2003
			WO 0039576 A1	06-07-2000

US 5440392	A	08-08-1995	AU 664393 B2	16-11-1995
			CA 2119769 A1	15-04-1993
			DE 69213749 D1	17-10-1996
			DE 69213749 T2	06-03-1997
			EP 0607303 A1	27-07-1994
			JP 3070953 B2	31-07-2000
			JP H06511555 A	22-12-1994
			NO 913994 A	13-04-1993
			US 5440392 A	08-08-1995
			WO 9307443 A1	15-04-1993

WO 2008113147	A2	25-09-2008	BR PI0700926 A	02-01-2008
			WO 2008113147 A2	25-09-2008
