

Remotized Control of Power Electronic Devices Exploiting a Plastic Optical Fiber Photonic Bus

*Original*

Remotized Control of Power Electronic Devices Exploiting a Plastic Optical Fiber Photonic Bus / Varatharajan, Anantaram; Savio, Paolo; Vizzaccaro, Erasmo; Abrate, Silvio; Pellegrino, Gianmario; Curri, Vittorio. - ELETTRONICO. - 2018-(2018), pp. 1-4. ( 20th International Conference on Transparent Optical Networks, ICTON 2018 Bucharest (RO) 2018) [10.1109/ICTON.2018.8473992].

*Availability:*

This version is available at: 11583/2727308 since: 2019-03-07T09:04:54Z

*Publisher:*

IEEE Computer Society

*Published*

DOI:10.1109/ICTON.2018.8473992

*Terms of use:*

This article is made available under terms and conditions as specified in the corresponding bibliographic description in the repository

*Publisher copyright*

(Article begins on next page)

# Remotized Control of Power Electronic Devices Exploiting a Plastic Optical Fiber Photonic Bus

Anantaram Varatharajan<sup>(1)</sup>, Paolo Savio<sup>(2)</sup>, Erasmo Vizzaccaro<sup>(3)</sup>,  
Silvio Abrate<sup>(2)</sup>, Gianmario Pellegrino<sup>(1)</sup>, Vittorio Curri<sup>(3)</sup>

<sup>(1)</sup>DENERG, Politecnico di Torino, Torino, Italy, [gianmario.pellegrino@polito.it](mailto:gianmario.pellegrino@polito.it)

<sup>(2)</sup>Istituto Superiore Mario Boella, Torino, Italy, [savio@ismb.it](mailto:savio@ismb.it)

<sup>(3)</sup>DET, Politecnico di Torino, Torino, Italy, [www.optcom.polito.it](http://www.optcom.polito.it), [curri@polito.it](mailto:curri@polito.it)

## ABSTRACT

The Internet of Things paradigm and the ubiquitous diffusion of Power Electronic Converters in many fields of application are suggesting the possibility of new ICT services associated to advanced power conversion. This work investigates the feasibility of shared centralized control and communications units able to control and synchronize different power converters, enabling real-time control and telemetry with a cloud approach on the Internet. Our research is focused on defining a proper communication bus making communications between devices and their remote control and telemetry possible in such a challenging environment.

**Keywords:** Plastic optical fiber, power electronics, remote control

## 1. INTRODUCTION

Power electronic converters (PECs) are assuming a fundamental role in the modern society, in rapid growth thanks to vehicles electrification and power generation from renewable sources, and the related conversion and energy storage. Traditionally, each PEC has a dedicated embedded controller on board. In this work, we propose an original solution for remotizing the control of PECs using a bus made of standard pairs of A4a.2 Poly Methyl MethAcrylate (PMMA) Step Index plastic optical fiber (POF). Optical fibers offer immunity towards electromagnetic interference coming from PECs, and a high data transfer rate and low latency for the purposes of PEC tele-controlling, diagnostics and data collection from the field. POFs enable also high mechanic and chemical resilience.

In the literature, very few examples of application of optical fibers to PECs are reported: to command the gate drivers of PECs [1], or to supply the gate drivers through power over wire in PECs for high voltage applications [2], or to sense the temperature of the power devices [3-4]. In all the reported cases, the optical link was used in “one signal per fiber” manner, no attempt is reported to establishing a link for real-time high data transfer rate between PECs and the control unit (CU).

This work proposes an original protocol capable to manage more than 10 devices in real-time by relying on time-division multiplexing, with a maximum distance between PECs and of PECs from the CU of 40m. The choice for plastic fibers as transmission media is driven by their low cost, ruggedness and ease of deployment, as they can be simply cut using a pair of scissors and inserted in optolock transceivers without any specific precautions nor special tools. We also depict future evolutions towards the integration of remotized control with local area networks (LAN) by exploiting the Ethernet protocol, so enabling telemetry and remote management of PECs on the Internet with a cloud approach: The Internet of Power paradigm.

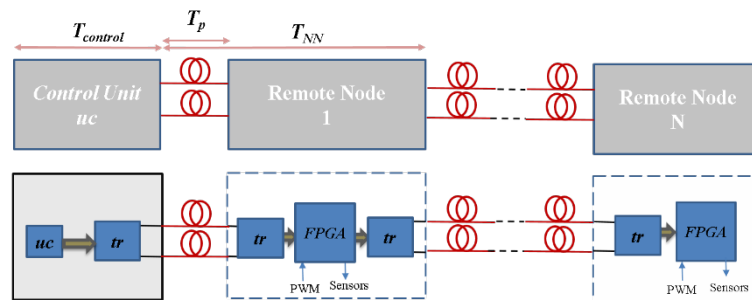

Figure 1. Scheme for the proposed TDM control setup based on a daisy-chain connected by POF links.

## 2. PHOTONIC BUS: IMPLEMENTATION AND PROTOCOL

POFs have been recently used for data transmission on short distances and relatively low data rates in scenarios where other technologies such as UTP cables, Wi-Fi and Powerline cannot be effectively deployed because of coexistence with power cables generating unbearable electromagnetic interferences. In [7], we implemented an Ethernet to POF media converter with 425m reach and then updated the setup to support Gigabit Ethernet [5, 6, 8]; the proposed work is an extension of these results by adapting the optical protocol to industrial controls. The chosen transmission medium made of standard pairs of PMMA Step Index POF has a refractive index  $n = 1.4$ , this

implies that the propagation velocity in the fiber determining delays is  $v = c/n = 2.14 \cdot 10^8$  m/s, where  $c$  is the vacuum light velocity.

In Fig. 1, we present the scheme for the remote controlling and related time-division multiplexing (TDM) protocol that we propose. The CU is connected to the remote nodes by a POF-based daisy-chain of remote nodes. The remote PECs have an on-board Field Programmable Gate Arrays (FPGAs) to transmit the data (upstream) from sensors measurements and to implement the received Pulse Width Modulation (PWM) signals from the CU. To handle the real time communication between PECs and the CU, the transmission time must be sufficiently low to meet the PWM update rate, therefore, the scheme of Fig. 2 is considered.

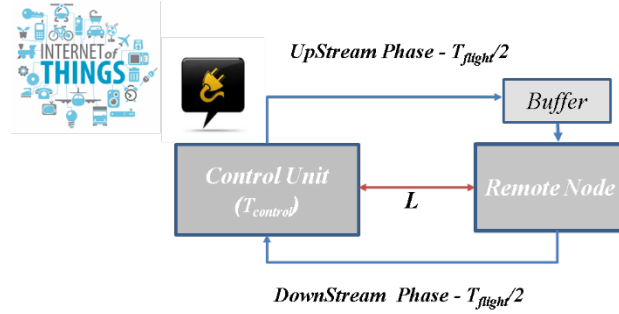

Figure. 2. Data transmission scheme

In Fig.2.,  $T_{flight}$  represents the maximum allowed roundtrip transmission time, given by the difference between the maximum latency  $T_{max}$  and the processing time of the control unit ( $T_{control}$ ). In the figure,  $L$  is the distance of transmission. The maximum distance that can be reached with this kind of scheme is  $L_{max} = \frac{T_{flight}}{2} v$ . A buffer is introduced to explicitly model the time needed to elaborate the packets that arrive to the control unit. The relationship between the buffer and the propagation time  $T_p$ .

$$T_p < \frac{T_{flight}}{2} \Rightarrow T_{buffer} = T_{flight} - 2 T_p \quad (1)$$

Fig.3 displays the transfer of a packet from the remote node to the control unit (CU) and its response.

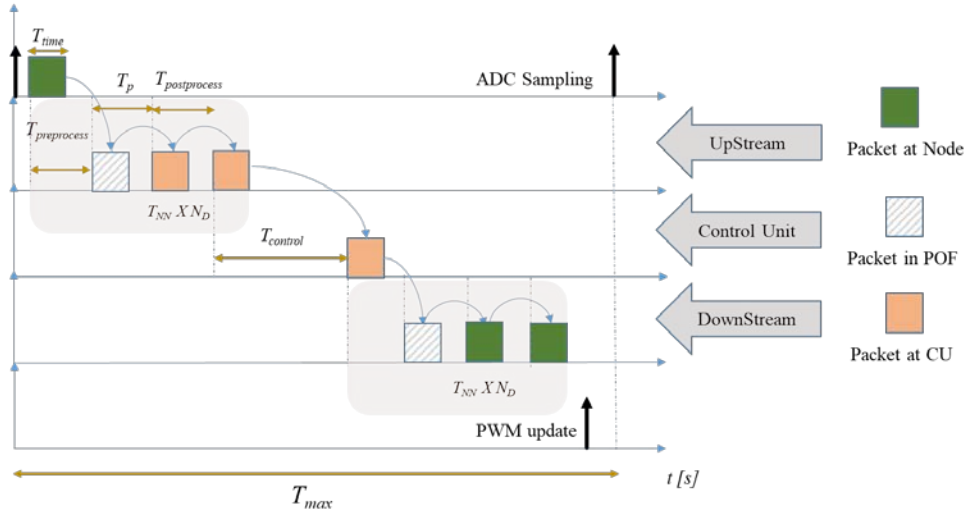

Figure.3. Timing diagram of the proposed scheme

It can be observed that during the upstream phase, at the trigger, a packet of length  $T_{time}$  is constructed after a small time lapse due to ADC sampling and is pre-processed for parallel-to-serial conversion at the remote node prior to the transmission within  $T_{preprocess}$ . The packet flows through the intermediate node in the daisy-chain structure before reaching the CU. At each node, the packet is processed to check for the target identifier. Assuming the nodes are equidistant,  $T_p$  denotes the propagation delay between the two nodes. The received packet at the CU is postprocessed for serial to parallel conversion within  $T_{postprocess}$ ; the time  $T_{control}$  denotes the computation time of CU to process the measured data and to determine the future states of the inverter. This information is transmitted back downstream in similar fashion and the PWM registers are updated.

In Fig.3, the length of the packet is calculated as  $T_{time} = \frac{N_{bit}}{R_b}$ ; the internodal propagation time in POF between the two nodes  $T_p$  is related to the fiber length  $L$  by  $T_p = \frac{L}{v}$ ; the single trip internodal transmission time  $T_{NV}$  is

given by  $T_{NN} = 2T_{time} + T_p$ , where for simplicity,  $T_{preprocess} = T_{postprocess} = T_{time}$ ;  $N_D$  is the number of nodes. For the transmission over the fiber, the maximum latency  $T_{max} = 100 \mu\text{s}$  was considered as 10 kHz is standard PWM switching frequency; the packet length of 128 bits was considered also accounting for overhead. The roundtrip time ( $R_{TT}$ ) in a single node system is given by  $link_{RTT} = 2T_{NN} + T_{control}$ .

Fig.4 shows the sensitivity of the roundtrip time for a single node system against the variation of 3 parameters namely: Length of the fiber ( $L$ ); Bit rate ( $R_b$ ); Computational Time ( $T_{control}$ ). The Guard time between two packet ( $T_{guard}$ ) is taken into account only for a TDM scheme and not for a one node scheme. For each parameter variation, the other specifications are maintained at their optimal value:  $L = 40 \text{ m}$ ,  $R_b = 250 \text{ Mbit/s}$ ,  $T_{control} = 30 \mu\text{s}$ ,  $T_{max} = 100 \mu\text{s}$  and  $T_{guard} = 2 \mu\text{s}$ .

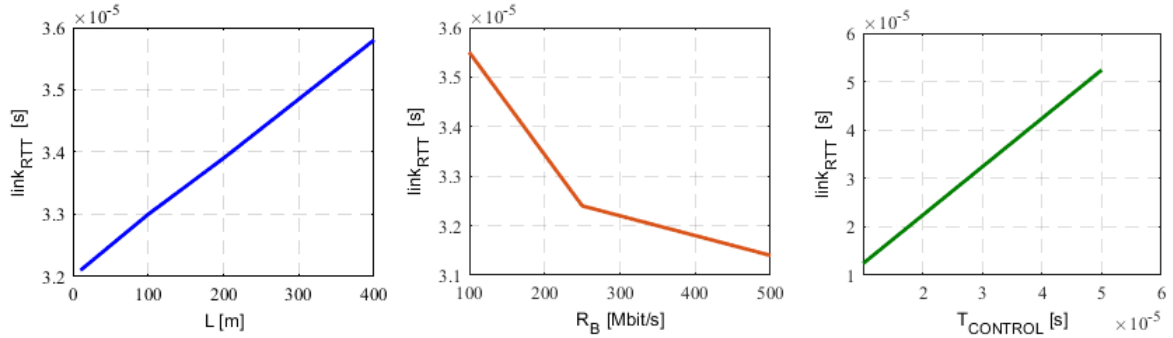

Figure 4. Roundtrip in single node system

**i) L variation:** system parameters are computed for different values of  $L$ . Increasing the length of the fiber, the time for the roundtrip also increases. It must be pointed out that the additional time arises from the increase in the propagation time  $T_p$  within the POF. Given the optimal conditions, for  $L = 40 \text{ m}$ , the upper limit of number of remote nodes  $N_{D-max} = 15$  and increasing the distance  $L$  to 400 m decreases the  $N_{D-max}$  to 8.

**ii) R<sub>b</sub> variation:** the bitrate determines  $T_{time}$  for a given length of the packet (128 bits). An inverse relation is observed with the roundtrip trip. At 250 Mbit/s,  $N_{D-max}$  is 15 and increases to 20 at 500 Mbit/s.

**iii) T<sub>control</sub> variation:** the control computation time depends on the complexity of the motor control algorithm. From the above figures, it is clear that this parameter has the greatest influence on the available roundtrip time. The maximum number of nodes  $N_{D-max}$  varies from 20 at 10  $\mu\text{s}$  to 11 at 50  $\mu\text{s}$ .

**iv) T<sub>guard</sub> variation:** The guard time  $T_{guard}$  represents the minimum time window between the two consecutive packets transmitted by the CU. This does not influence the roundtrip time but is related to the number of devices by:

$$N_{D-max} = \frac{T_{MAX} - T_{control}}{2T_{NN} + T_{guard}} \quad (2)$$

which is equal to 20 for  $T_{guard} = 1 \mu\text{s}$  and to 15 for  $T_{guard} = 2 \mu\text{s}$

In general, we propose a protocol capable to manage up to more than 10 devices in real-time by relying on time-division multiplexing (TDM), with a maximum distance of between adjacent nodes of 40 meters. In particular, with this protocol we are able to manage up to 15 devices, in optimal conditions.

In our implementation, the system transmits and receives two packet types:

- IDLE packets (field type 0x1E), which fill up the channel most of the time
- A couple of data packets, the first marked as START, the second marked as STOP, with 96 bits of useful data, both upstream and downstream.

**Downstream data** - Source node identifier, 3-phase PWM signal and (optional) initialization command/telemetry.

**Upstream data** - Source node identifier, 3-phase current feedback, quadrature encoder for mechanical rotor position and (optional) initialization command/telemetry.

### 3. PROOF-OF-CONCEPT DEMONSTRATOR

When building the proof of concept, in addition to the timing requirements explained in the previous section, we considered also the total cost and the relatively short fiber distances needed. The system cost and ease of use constraints drove us to choosing an integrated, tool-less transceiver solution commercially available: the optolock design allows for establishing a connection by just cutting the fiber ribbon with a pair of scissors and locking it into the correct position. As we are targeting short distances, POF optical bandwidth does not deteriorate received data, so we do not need to reconstruct the transmitted waveform using A/D conversion and filtering implemented in Digital Signal Processing, as we did in our previous work [5].

The strict real-time requirements impeded to relying on a Forward Error Correction code as the Reed Solomon 237,255 used in [5], limiting the link length to the 40m at 250Mb/s declared by the transceiver manufacturer. In

order to successfully operate the optical channel, both DC balancing and an adequate data transition density are needed: these requirements are fulfilled by adopting a line code such as the 64/66b. This line coding is widely adopted – e.g., in 10G Ethernet – because it requires a 2 bit overhead over 64 bit words with a limited 3% overhead, and enables a more efficient data transmission. Moreover, the transition density and the DC balancing are randomized by scrambling the data and control words with a known polynomial before optical transmission.

On the power unit – the remote node –, a Finite State Machine takes care of handling PWM update and ADC sampling. On the CU, as soon as a packet is received, an interrupt is raised and the microcontroller core can access those values on five registers, memory mapped on a known location. Once the algorithm computation is completed, the updated PWM duty cycle values are written on the registers of the transmit section and the downstream packet is ready to be sent to the target node.

The first trials have been performed sharing a single clock all over the network to synchronize transmitters and receivers. As a further development step, a clock and data recovery section has been added to each of the nodes to take care of the small frequency differences among nominally equal clock sources. Among all the possible clock and data recovery approaches, we have selected a fully digital solution able to recover all the incoming bits. Incoming asynchronous data stream is oversampled at 4X its nominal rate and the recovered bits are inserted in a FIFO, deep enough to account for small clock variations and jitter. As it is typical for this solution, the receiver FIFO that moves data from the asynchronous clock domain to the internal system clock can encounter an underflow (the clock on the receiver is slightly faster than the transmitter) or an overflow condition. The control logic solves this situation by adding/removing an IDLE word after the descrambling section of the 64/66b decoder.

The remote node was built around a commercial mini-module with a Xilinx Artix FPGA, an integrated optical transceiver and two 2.54mm spaced expansion slots; and the two units are connected by a 40m POF pair and successfully managed to control a three-phase voltage source inverter, used for vector control of a brushless servomotor. The servomotor is rated 100 W, 6000 rpm, and the PEC is a X-Nucleo-IHM08M1, a 60 V dc input, 15 A ac output expansion board for STM32 Nucleo boards by ST-microelectronics. The PEC and servomotor are purposely off-the-shelf equipment and of small size, as the emphasis here is on demonstrating the real-time control capability via POF. A custom adapter board has been developed to connect the FPGA module to a ST expansion board and to a second optical transceiver to daisy-chain more units. For the control unit, a commercial board with a Xilinx Zynq FPGA is chosen; such a component is suitable to our prototyping purposes, having on board both FPGA and ARM micro-controller capabilities; the optical transceiver has been added on one expansion connector.

#### 4. CONCLUSIONS

A proof-of-concept demonstrator was designed to validate the POF-based PEC control concept in hardware and it is presented here for the first time. We successfully defined an optical fiber bus architecture capable of connecting and controlling a chain of power electronic nodes. Limiting factors to the computation time that the control unit can dedicate to the nodes, to the refresh frequency of the PECs and to the available bandwidth of the fiber were discussed. Next steps of this activity within the power electronic innovation center (PEIC) of Politecnico di Torino will see the experimental validation of the proposed idea, and the extension to controlling a higher number of PECs and to more challenging power electronic devices.

#### ACKNOWLEDGEMENTS

This work was performed within the Power Electronic Innovation Center (PEIC) of Politecnico di Torino

#### REFERENCES

- [1] S. Brehaut and F. Costa, "Gate driving of high power IGBT by wireless transmission," in *2006 CES/IEEE 5th International Power Electronics and Motion Control Conference*, 2006, vol. 1, pp. 1–5.
- [2] X. Zhang *et al.*, "A 15 kV SiC MOSFET gate drive with power over fiber based isolated power supply and comprehensive protection functions," *APEC* 2016, pp. 1967–1973.
- [3] J. P. Bazzo *et al.*, "Thermal characteristics analysis of an IGBT using a fiber Bragg grating," *Opt. Lasers Eng.*, vol. 50, no. 2, pp. 99–103, 2012.
- [4] K. M. Sousa *et al.*, "Optical fiber Bragg grating sensors applied on energy conversion systems," in *2013 SBMO/IEEE MTT-S International Microwave & Optoelectronics Conference (IMOC)*, 2013, pp. 1–5.
- [5] Nespola, A., S. Straullu, P. Savio, S. Abrate, D. Cardenas, J. C. Ramirez Molina, N. Campione, R. Gaudino, and D. Zeolla, "First demonstration of real-time LED-based Gigabit Ethernet transmission on 50m of A4a.2 SI-POF with significant system margin", *ECOC 2010*, Torino, Italy
- [6] P. Savio *et al.*, "A Physical Coding Sublayer for Gigabit Ethernet over POF", *19th International Conference on Plastic Optical Fibers*, Yokohama, Japan, 10/2010.
- [7] D. Cárdenas *et al.*, "A media converter prototype for 10-Mb/s ethernet transmission over 425 m of large-core step-index polymer optical fiber. *Journal of Lightwave Technology*, 2006. 24(12): p. 4946.
- [8] ETSI recommendation "Plastic Optical Fibre System Specifications for 100 Mbit/s and 1 Gbit/s" (TS 105 175-1).
- [9] O. Ziemann *et al.*, "POF handbook: optical short range transmission systems", 2nd ed., Springer-Verlag GmbH, 2008