

Development of a pressure-based technique to control IMEP and MFB50 in a 3.0L diesel engine

Original

Development of a pressure-based technique to control IMEP and MFB50 in a 3.0L diesel engine / Finesso, Roberto; Marelo, Omar; Spessa, Ezio. - In: ENERGY PROCEDIA. - ISSN 1876-6102. - STAMPA. - 148:(2018), pp. 424-430. (73° CONGRESSO NAZIONALE ATI Pisa 12-14 September, 2018) [10.1016/j.egypro.2018.08.105].

Availability:

This version is available at: 11583/2720239 since: 2018-12-11T13:29:17Z

Publisher:

Elsevier

Published

DOI:10.1016/j.egypro.2018.08.105

Terms of use:

This article is made available under terms and conditions as specified in the corresponding bibliographic description in the repository

Publisher copyright

(Article begins on next page)



73rd Conference of the Italian Thermal Machines Engineering Association (ATI 2018),
12–14 September 2018, Pisa, Italy

Development of a pressure-based technique to control IMEP and MFB50 in a 3.0L diesel engine

Roberto Finesso, Omar Marello*, Ezio Spessa

*IC Engines Advanced Laboratory, Dipartimento Energia, Politecnico di Torino
c.so Duca degli Abruzzi 24, 10129 - Torino, Italy*

Abstract

A pressure-based technique for the control of IMEP (Indicated Mean Effective Pressure) and MFB50 (crank angle at which 50% of fuel mass fraction has burned) has been developed, assessed and tested by means of MiL (Model-in-the-Loop) on a 4 cylinder 3.0L Euro VI diesel engine.

The activity was carried out in the frame of a research project in collaboration with FPT Industrial.

The developed controller is of the closed-loop type. It receives, as input, the desired targets of IMEP and MFB50 for each cycle and cylinder and performs a cycle-by-cycle and cylinder-to-cylinder correction of the injected fuel quantity of the main pulse (q_{main}) and of the start of injection of the main pulse (SOI_{main}), in order to reduce the deviation between the actual and target values of IMEP and MFB50, respectively. The method is referred to as “pressure-based” since it requires the measurement of the in-cylinder pressure trace for each cylinder in order to extract the actual values of IMEP and MFB50. In fact, the actual IMEP value can be estimated by integrating the pressure signal with respect to the in-cylinder volume. At the same time, the actual MFB50 value can be extracted from the heat release curve, which is obtained from the in-cylinder pressure trace by using a single-zone heat release model. The proposed control technique has been developed in Simulink environment, and has been assessed and tested on an engine emulator which is constituted by a GT-power model of the 3.0L diesel engine. The controller has been tested in transient operation over a load ramp profile at different engine speeds and over a WHTC interval, and demonstrated to have a good potential for IMEP and MFB50 control, since it is characterized by a fast response and a limited overshoot behavior.

© 2018 The Authors. Published by Elsevier Ltd.

This is an open access article under the CC BY-NC-ND license (<https://creativecommons.org/licenses/by-nc-nd/4.0/>)

Selection and peer-review under responsibility of the scientific committee of the 73rd Conference of the Italian Thermal Machines Engineering Association (ATI 2018).

Keywords: diesel; control; IMEP; MFB50

1. Introduction

Interest in the development of combustion control algorithms for internal combustion engines is growing among car manufacturers, due to the increasing computational performance of ECUs (Engine Control Units) [1-2]. This is especially true for

* Corresponding author. Tel.: +39-011-090-4493; fax: +39-011-090-4599.

E-mail address: omar.marello@polito.it

diesel engines, which are characterized by a high degree of complexity and by large number of control variables and calibration parameters. Although diesel engines have become quite unpopular in the last few years, especially for passenger-car applications, it is generally agreed they will remain the main propulsion system for light-duty and heavy-duty commercial vehicles at least for the next 20-30 years. Therefore, an important research effort is still oriented to the development of solutions to further reduce pollutant emissions and fuel consumption from diesel combustion. The development of combustion control algorithms can lead to a significant contribution to this aim.

Different types of combustion control algorithms have been developed in the literature, such as model-based algorithms, sensor-based algorithms of a combination of them [1]. Model-based combustion control algorithms are typically based on the use of a low-throughput combustion models (see, for example, [3-7]), which are typically used to extract the main combustion, performance and emission metrics of the engine in real time. Some examples of these metrics are MFB50 (crank angle at which MFB50 is burnt), PFP (Peak Firing Pressure), IMEP/BMEP (Indicated/Brake Mean Effective Pressure), NO_x and soot emissions. The model-based approach is typically of the open-loop type, since it is not based on the use of feedback sensors. This is a positive aspect in terms of costs. However, model-based combustion controllers are typically not able to provide a cylinder-to-cylinder combustion control and their accuracy depends on the model predictive capability. Sensor-based combustion control algorithms are instead based on the use of sensors installed on the engine, and are typically of the closed-loop type [1, 8]. They offer a higher accuracy compared to model-based algorithms and the capability of achieving a cylinder-to-cylinder combustion control [1]. However, they require the installation of physical sensors on the engine with the related costs.

Given the previous background, a closed-loop pressure-based controller of IMEP (Indicated Mean Effective Pressure) and MFB50 (crank angle at which 50% of fuel mass fraction has burned) has been developed, assessed and tested by means of MiL (Model-in-the-Loop) on a four cylinder 3.0L Euro VI diesel engine for light-duty applications.

The method is referred to as “pressure-based” since it requires the measurement of the in-cylinder pressure trace for each cylinder in order to extract the actual values of IMEP and MFB50.

The activity was carried out in the frame of a research project in collaboration with FPT Industrial.

The controller has been developed in Simulink environment, and has been assessed and tested through Model-in-the-Loop (MiL) on an engine emulator which is constituted by a GT-power model of the 3.0L diesel engine.

The experimental tests for the model calibration were performed on a highly dynamic test bench at the Politecnico di Torino.

Nomenclature

BMEP	Brake Mean Effective Pressure
IMEP	Indicated Mean Effective Pressure
K	model parameter related to combustion rate
MFB	burned fuel mass fraction metric
MiL	Model-in-the-Loop
N	Engine speed
PFP	Peak Firing Pressure
q _{main}	total injected fuel volume of the main pulse
SOI _{main}	Start of Injection of the main pulse
WHTC	World Harmonized Transient Cycle

2. Engine specifications and experimental setup

The main engine technical specifications are summarized in Tab. 1.

Table 1. Main engine specifications.

Engine type	FPT F1C Euro VI diesel engine
Displacement	2998 cm ³
Bore x stroke	95.8 mm x 104 mm
Rod length	104 mm
Compression ratio	17.5
Valves per cylinder	4
Turbocharger	VGT type
Fuel injection system	High pressure Common Rail

The engine is equipped with a short-route cooled EGR system, in which the EGR valve is located upstream from the cooler. A flap is installed in the exhaust pipe downstream the turbine, to control the temperature of the exhaust gas flowing to the aftertreatment system and to allow high EGR rates to be obtained when the pressure drop between the exhaust and intake manifolds is not sufficiently high. The test engine was instrumented with piezoresistive pressure transducers and thermocouples

to measure the pressure and temperature at different locations, such as upstream and downstream from the compressor, from the turbine and intercooler, in the intake manifold and in the EGR circuit. Thermocouples were also used to measure the temperatures in each intake and exhaust runners. KISTLER 6058A high-frequency piezoelectric transducers were fitted to the glow-plug seat to measure the in-cylinder pressure time-histories, which can be used for the developed pressure-based controller of IMEP and MFB50. The in-cylinder pressure traces were corrected on the basis of the intake pressure that was measured by means of high-frequency KISTLER 4007C piezoresistive transducers, which were located at the inlet runners of the cylinders.

All the experimental tests were carried out on the highly dynamic test bed at ICEAL at the Politecnico di Torino. A detailed description of the test bench can be found in [1].

3. Developed controller

The developed pressure-based controller of MFB50 and IMEP exploits the measurement of the in-cylinder pressure in the combustion chamber of each cylinder. In short, MFB50 and IMEP targets (i.e., $MFB50_{tgt}$, $IMEP_{tgt}$) are identified at a given time instant. The actual MFB50 and IMEP values are extracted from the measured in-cylinder pressure of each cylinder at each cycle, and the start of injection of the main pulse (i.e., SOI_{main}) and the total injected fuel quantity of the main pulse (q_{main}) are then adjusted in the subsequent cycle in order to achieve the desired MFB50 and IMEP targets, respectively, according to a closed-loop approach.

The actual MFB50 value is derived from the net energy release Q_{net} , which in turn is estimated from the measured in-cylinder pressure on the basis of a single-zone approach [9], as follows

$$dQ_{net} = \frac{\gamma}{\gamma-1} p dV + \frac{1}{\gamma-1} V dp \quad (1)$$

where $\gamma=1.37$, p is the measured in-cylinder pressure and V is the in-cylinder volume. It should be noted that, in general, γ depends on the composition of the burned gas (see [7]). However, for this application the value of γ was set constant and equal to 1.37 has been set in order to be coherent with the outcomes of the acquisition software installed at the test bench, which implements the abovementioned value of γ .

The net energy release curve is then normalized to its maximum value in order to estimate the burned mass fraction curve, and MFB50 is obtained as the crank angle at which the normalized heat release curve is equal to 0.5.

The actual IMEP value is instead evaluated as follows:

$$IMEP = \frac{\int_0^{720} p dV}{V_{cyl}} \quad (2)$$

where V_{cyl} is the displacement of the cylinder.

The MFB50 and IMEP correction algorithms are described hereafter.

The actual MFB50 value for the generic cylinder ‘j’ and cycle ‘i’, i.e., $MFB50_i^j$, is compared with the target value, i.e., $MFB50_{tgt,i}^j$. The error between the target and the actual values of MFB50 is then estimated as follows:

$$MEFB50_{err,i}^j = MFB50_{tgt,i}^j - MFB50_i^j \quad (3)$$

The start of injection of the main pulse in the subsequent cycle, ‘i+1’, is corrected according to the following equation:

$$SOI_{main,i+1}^j = SOI_{main,i}^j + K_{SOI,i}^j \cdot MFB50_{err,i}^j + K_{d,SOI} \left(MFB50_{err,i}^j - MFB50_{err,i-1}^j \right) \quad (4)$$

where $K_{SOI,i}^j$ is a modulation factor that was introduced in order to optimize the response of the controller and to guarantee stable operations, and $K_{d,SOI}$ was set equal to 0.0167.

With reference to the correction scheme of Eq. (4), it was verified that the behavior of the control can be unstable if the value of the modulation factor of the MFB50 error is not properly adjusted cycle-by-cycle. An optimal strategy for the definition of this parameter was thus identified in order to guarantee a fast response of the controller and to avoid the occurrence of instability. In particular, the value of the modulation factor was varied, cycle-by-cycle, as a function of the sign of the MFB50 error between two consecutive cycles, according to the following method:

$$\begin{aligned}
K_{SOI,i}^j &\in [0.03, 0.5] \\
\text{if } \text{sign}(MFB50_{err,i}^j) &= \text{sign}(MFB50_{err,i-1}^j): K_{SOI,i}^j = K_{SOI,i-1}^j \cdot 2 \\
\text{if } \text{sign}(MFB50_{err,i}^j) &\neq \text{sign}(MFB50_{err,i-1}^j): K_{SOI,i}^j = \frac{K_{SOI,i-1}^j}{2} \\
\text{if } MFB50_{err,i}^j &\geq 3 \text{ deg } K_{SOI,i}^j = 0.5
\end{aligned} \tag{5}$$

With reference to IMEP, the actual IMEP value for the generic cylinder ‘j’ and cycle ‘i’, i.e., $IMEP_i^j$, is compared with the target value, i.e., $IMEP_{tgt,i}^j$. The error between the target and the actual values of IMEP is then estimated as follows:

$$IMEP_{err,i}^j = IMEP_{tgt,i}^j - IMEP_i^j \tag{6}$$

The injected fuel quantity of the main pulse in the subsequent cycle, ‘i+1’, is corrected according to the following equation:

$$q_{main,i+1}^j = q_{main,i}^j + K_{q,i}^j \cdot IMEP_{err,i}^j + K_{d,q} \left(IMEP_{err,i}^j - IMEP_{err,i-1}^j \right) \tag{7}$$

where $K_{q,i}^j$ is a modulation factor that was introduced (similarly to $K_{SOI,i}^j$) in order to optimize the response of the controller and to guarantee stable operations. The coefficient of the derivative part of the controller was also tuned to optimize the controller response, and the optimal value that was identified is equal to 1.46.

Similarly to $K_{SOI,i}^j$, also the value of $K_{q,i}^j$ was varied, cycle-by-cycle, as a function of the sign of the IMEP error between two consecutive cycles, according to the following method:

$$\begin{aligned}
K_{q,i}^j &\in [0.8, 2.8] \\
\text{if } \text{sign}(IMEP_{err,i}^j) &= \text{sign}(IMEP_{err,i-1}^j): K_{q,i}^j = K_{q,i-1}^j \cdot 2 \\
\text{if } \text{sign}(IMEP_{err,i}^j) &\neq \text{sign}(IMEP_{err,i-1}^j): K_{q,i}^j = \frac{K_{q,i-1}^j}{2} \\
\text{if } IMEP_{err,i}^j &\geq 1.5 \text{ bar } : K_{q,i}^j = 2.8
\end{aligned} \tag{8}$$

Fig. 1 shows a scheme of the developed controller.

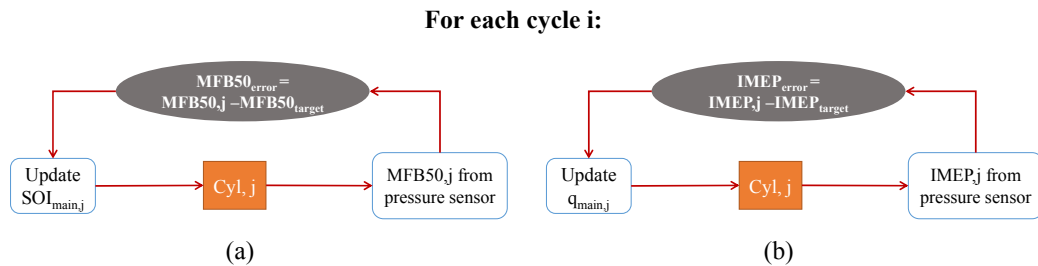

Fig. 1. Scheme of the developed pressure-based controller of MFB50 and IMEP.

4. Model-in-the-loop (MiL)

The proposed controller was developed in Matlab Simulink environment and tested through Model-in-the-Loop (MiL) methodology, by coupling the Simulink tool to an engine emulator that was constituted by a fast-running engine model developed in GT-power.

The tests were performed on a 2.8GHz i7 PC. The fast-running GT-power model scheme is represented in Fig.2.

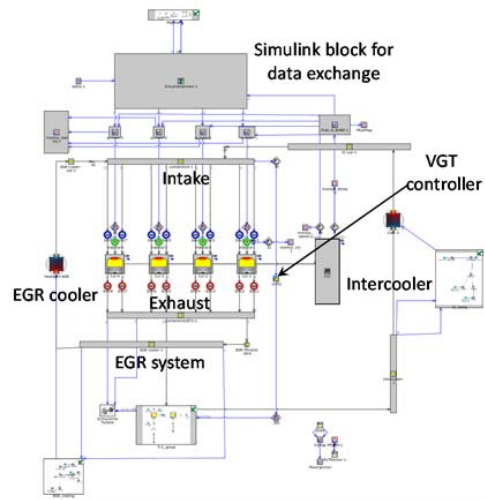

Fig. 2. Scheme of the fast-running GT-power model used for MiL applications.

The fast-running model was developed by simplifying a detailed GT-power engine model (see [1]). The simplification consisted in reducing the number of pipes, in increasing the discretization length and in simplifying the EGR cooler and intercooler systems, while maintaining the same detailed simulation as the in-cylinder combustion process (the DIPulse V73 embedded submodel was used). It can be seen in the figure that a block was included in order to exchange data with the Simulink software during the MiL simulations. The Simulink tool receives the actual MFB50 and IMEP values of each cylinder from GT-power, performs the SOI_{main} and q_{main} corrections according to Eqs. (3-8), and sends the updated values of SOI_{main} and q_{main} back to GT-power for each injector. Details on the accuracy of the fast-running GT-power model can be found in [1].

5. Results and discussion

The developed controller has been assessed through the MiL methodology over a load ramp profile at 2000 rpm, 2750 rpm and 3500 rpm and over the WHTC, which is characterized by a duration of 1800s. With reference to the latter, a specific time interval (which is characterized by a highly transient profile of speed and BMEP) has been selected for the result analysis. Figure 3 shows the load ramp profile as a function of time (a) and the selected WHTC interval.

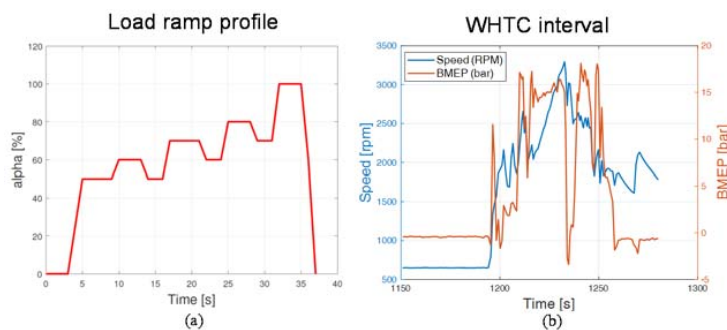

Fig. 3. Load ramp profile (a) and WHTC interval (b) as a function of time ('alpha' indicates the accelerator pedal position).

The results are reported in Figs.4-5. In particular, Fig. 4 reports the target and actual values of IMEP (Figs. 4a, 4b, 4c) and MFB50 (Figs. 4d, 4e, 4f) for the load ramp profile at 2000 rpm (Figs. 4a, 4d), 2750 rpm (Figs. 4b, 4f) and 3500 rpm (Figs. 4c, 4f), while Fig. 5 reports the results for the WHTC interval.

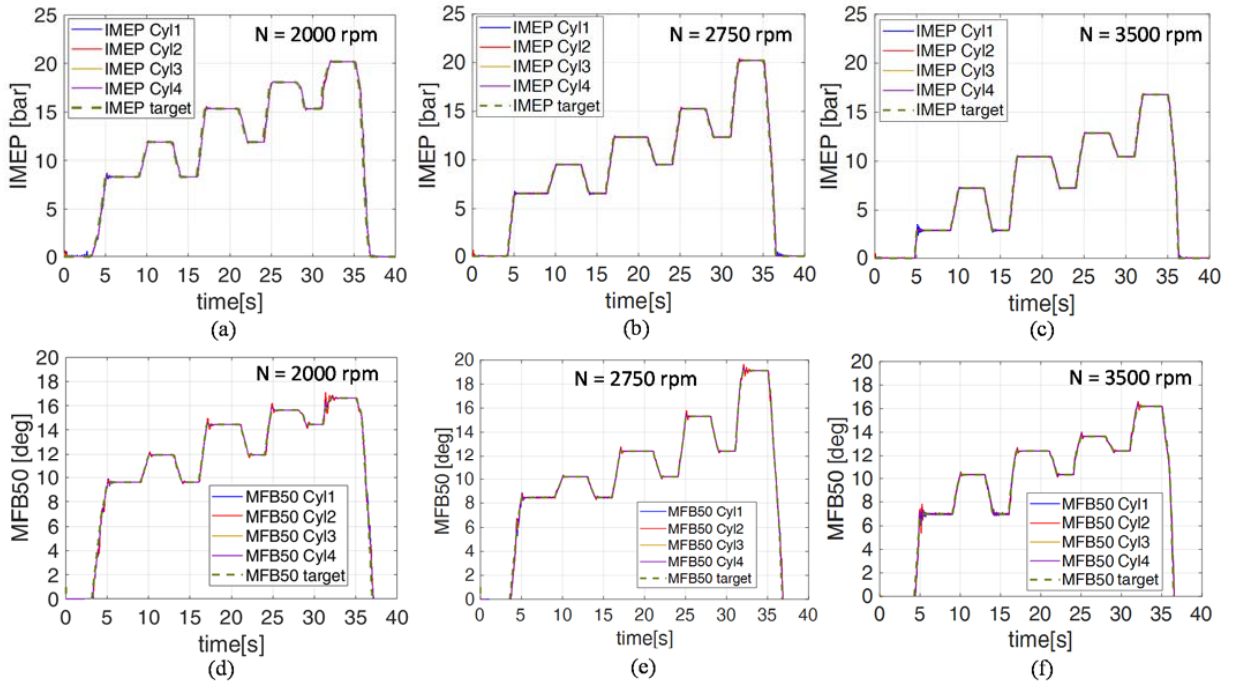

Fig. 4. Target vs. actual IMEP (a, b, c) and MFB50 (d, e, f) values over the simulated ramp profiles at 2000 rpm (a, d), 2750 rpm (b, e) and 3500 rpm (c, f).

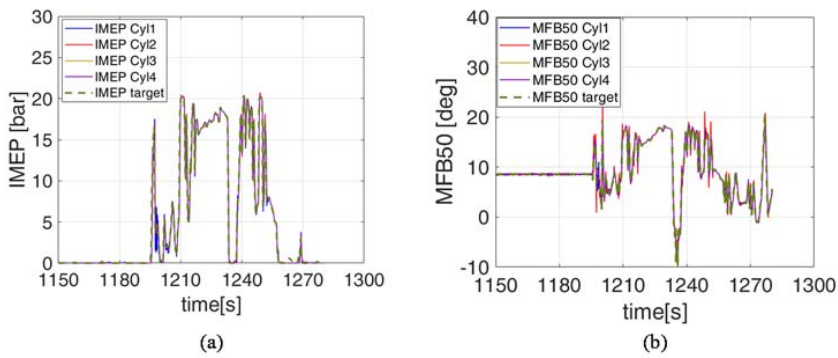

Fig. 5. Target vs. actual IMEP (a) and MFB50 (b) values over the selected WHTC interval.

It can be seen in the figures that the controller is capable of achieving the desired targets of IMEP and MFB50 with a fast response and limited overshoot/undershoot behavior in all the conditions for all the cylinders.

Some oscillations of MFB50 can be observed in limited regions of the load ramps (Figs. 4d-f), especially after the transition from a lower load to a higher load condition, and over the WHTC interval. These oscillations may be further reduced by introducing a modulation of the $K_{d,SOI}$ and $K_{d,q}$ factors in Eq (4) and Eq. (7), respectively, as a function of the error difference between two consecutive cycles. This refinement will be investigated in the near future.

Table 2 reports a summary of the RMSE (Root Mean Square Error) of IMEP and MFB50 for the analyzed tests.

Table 2. RMSE of IMEP and MFB50 for the load ramp profiles at 2000 rpm, 2750 and 3500 rpm

Test type	RMSE of IMEP (cyl 1/2/3/4)	RMSE of MFB50 (cyl 1/2/3/4)
Ramp at N= 2000 rpm	0.43/0.42/0.40/0.40 bar	0.27/0.30/0.24/0.24 deg
Ramp at N= 2750 rpm	0.33/0.32/0.31/0.31 bar	0.26/0.29/0.25/0.25 deg
Ramp at N= 3500 rpm	0.25/0.24/0.24/0.23 bar	0.69/0.69/0.66/0.68 deg
WHTC interval	0.85/0.79/0.71/0.70 bar	0.73/0.95/0.64/0.64 deg

Finally, some considerations should be done concerning the implementation of the developed controller on a commercial engine. The controller is of the closed-loop type, therefore it requires the measurement of the in-cylinder pressure, which can be carried out by means of pressure sensors embedded in the glow-plugs (e.g., see [10]). These sensors may be subject to a measurement drift over time, due to carbon deposits which may be formed on the sensor during the engine operation. Therefore, suitable compensation strategies (e.g., based on the check of the maximum in-cylinder pressure during cut-off conditions) should be developed and implemented in order to reduce this drift and guarantee the controller accuracy over time.

6. Conclusion

A pressure-based technique for the control of IMEP (Indicated Mean Effective Pressure) and MFB50 (crank angle at which 50% of fuel mass fraction has burned) has been developed, assessed and tested by means of MiL (Model-in-the-Loop) on a 4 cylinder 3.0L Euro VI diesel engine.

The activity was carried out in the frame of a research project in collaboration with FPT Industrial.

The developed controller is of the “pressure-based” closed-loop type. It receives, as input, the desired targets of IMEP and MFB50 for each cycle and cylinder and performs a cycle-by-cycle and cylinder-to-cylinder correction of the total injected fuel quantity (q_{main}) and of the start of injection of the main pulse (SOI_{main}), in order to reduce the deviation between the target and actual values of IMEP and MFB50, respectively. The latter are extracted from the in-cylinder pressure traces of each cylinder.

The proposed control technique has been developed in Simulink environment, and has been assessed and tested through MiL on an engine emulator which is constituted by a GT-power model of the 3.0L diesel engine.

The controller has been tested in transient operation over a load ramp profile at different speeds and a WHTC interval, and demonstrated to have a good potential for IMEP and MFB50 control, since it is characterized by a fast response and a limited overshoot behavior. The average values of the RMSE (Root Mean Square Error) of IMEP range from 0.3 to 0.8 bar, while the average values of the RMSE of MFB50 range from 0.2 to 0.9 deg.

Future activities will include the testing of the developed controller through Hardware-in-the-Loop (HiL) and Rapid Prototyping on the real engine.

Acknowledgements

FPT Industrial is kindly acknowledged for the technical support in the activities.

References

- [1] Finesso, R., Marelo, O., Spessa, E., Yang, Y. et al., "Model-Based Control of BMEP and NO_x Emissions in a Euro VI 3.0L Diesel Engine," SAE Int. J. Engines 10(5) (2017):2288-2304, doi:10.4271/2017-24-0057.
- [2] Finesso, R., Marelo, O., Misul, D., Spessa, E. et al., "Development and Assessment of Pressure-Based and Model-Based Techniques for the MFB50 Control of a Euro VI 3.0L Diesel Engine," SAE Int. J. Engines 10(4) (2017):1538-1555, doi:10.4271/2017-01-0794.
- [3] Finesso, R., Spessa, E., and Yang, Y., "Development and Validation of a Real-Time Model for the Simulation of the Heat Release Rate, In-Cylinder Pressure and Pollutant Emissions in Diesel Engines," SAE Int. J. Engines 9(1):322-341, 2016, doi:10.4271/2015-01-90449.
- [4] Finesso, R., Spessa, E., Yang, Y., Alfieri, V. et al., "HRR and MFB50 Estimation in a Euro 6 Diesel Engine by Means of Control-Oriented Predictive Models," SAE Int. J. Engines 8(3):1055-1068, 2015, doi:10.4271/2015-01-0879.
- [5] Chmela, F.G., and Orthaber, G.C., "Rate of Heat Release Prediction for Direct Injection Diesel Engines Based on Purely Mixing Controlled Combustion", SAE Technical Paper 1999-01-0186, 1999, doi:10.4271/1999-01-0186
- [6] Egnell, R., "A Simple Approach to Studying the Relation between Fuel Rate, Heat Release Rate and NO Formation in Diesel Engines", SAE Technical Paper 1999-01-3548, 1999, doi:10.4271/1999-01-3548
- [7] Catania, A.E., Finesso, R., Spessa, E., "Predictive Zero-Dimensional Combustion Model for DI Diesel Engine Feed-Forward Control", Energy Conversion and Management. 52(10):3159-3175, 2011, doi:10.1016/j.enconman.2011.05.003.
- [8] Olsson, J., Tunestål, P., and Johansson, B., "Closed-Loop Control of an HCCI Engine," SAE Technical Paper 2001-01-1031, 2001, doi: 10.4271/2001-01-1031.
- [9] Heywood, J.B., "Internal Combustion Engine Fundamentals", McGraw-Hill Intern. Editions, 1988.
- [10] Guido, C., Beatrice, C., Di Iorio, S., Napolitano, P., et al., "Assessment of closed-loop combustion control capability for biodiesel blending detection and combustion impact mitigation for an Euro5 automotive diesel engine". SAE technical paper 2011-01-1193; 2011. doi:10.4271/2011-01-1193.