

PERFORMANCE STUDY AND MATHEMATICAL MODEL OF AEROSPACE GEARED ROTARY ACTUATORS

*Original*

PERFORMANCE STUDY AND MATHEMATICAL MODEL OF AEROSPACE GEARED ROTARY ACTUATORS / Bertucci, Alessandro; Jacazio, Giovanni; Sorli, Massimo. - In: INTERNATIONAL JOURNAL OF APPLIED ENGINEERING RESEARCH. - ISSN 0973-4562. - Volume 13:Number 1(2018), pp. 167-174.

*Availability:*

This version is available at: 11583/2715522 since: 2018-10-22T19:47:49Z

*Publisher:*

Research India Publications

*Published*

DOI:

*Terms of use:*

This article is made available under terms and conditions as specified in the corresponding bibliographic description in the repository

*Publisher copyright*

(Article begins on next page)

# Performance Study and Mathematical Model of Aerospace Geared Rotary Actuators

Alessandro Bertucci<sup>1</sup>, Giovanni Jacazio<sup>2</sup> and Massimo Sorli<sup>3</sup>

<sup>1,2,3</sup> Department of Mechanical and Aerospace Engineering, Politecnico di Torino, 10129 Torino – Italy.

<sup>1</sup>Orcid: 0000-0001-6751-3247

## Abstract

Geared Rotary Actuators are mechanical devices widely used in the aerospace field to provide controlled motion to secondary flight control surfaces. Their use ranges from their application as powered hinges, when directly supporting the aerodynamic load forces in addition to the surface hinge moment, to actuators in linked mechanism where they provide the actuation torque and the aerodynamic load reaction is delegated to other load bearing equipment. In almost all cases, the GRAs are organized along the leading or trailing edge and are connected to each other via shafts and joints transferring the Power Drive Unit torque to the GRAs.

From a mechanical stand point, the GRAs can be classified as epicyclic gear reducer and their internal mechanical arrangement can be widely varied however the current industry state of the art focuses on two types.

This paper will describe their configuration, the governing equations, and the mathematical model that can be used to characterize the GRAs. The focus will be on the speed ratio calculation, the efficiency of the unit as function of the single geared meshing efficiency, the sources of drag and the torque output capability.

## Type 1 GRA Configuration

Type 1 geared rotary actuators (GRA T1) are mechanical assemblies performing speed reduction and torque amplification from the input shaft to the actuator output and providing reaction to the control surface loads. With reference to Figure 1, the actuator accepts input rotation and torque from the driveline at its input shaft (I). Speed reduction is obtained by means of a compound carrierless planetary gearset.

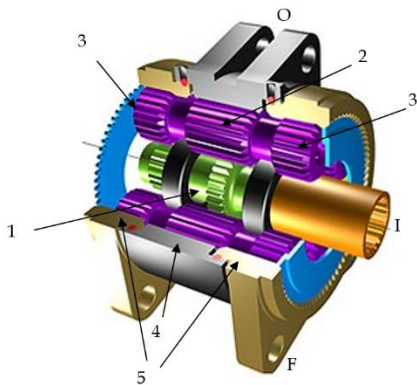

Figure 1: 3D section of a Type 1 geared rotary actuator

The compound planetary gear arrangement differs from a conventional epicyclic gear reducer by eliminating the carrier assembly for planetary gears. This is made possible by balancing the tangential teeth forces on the planetary pinions at the ring gear meshes. The compound planetary gearset contains a sun gear (1) receiving the input torque from the input shaft (I), a ring gear (4) providing the output torque to the driven element (O), two stationary ring gears (5) symmetrically placed at the two sides of the output ring gear (4). The power flow from the input to the output sun gears takes place through multiple planet gears meshing with the sun gears. Each planet gear consists of three pinions: the outer end pinion gears (3) are identical, as are the two fixed outer ring gears (5). For each planet gear the tooth load at the center mesh is reacted by the two identical forces at the fixed meshes. A full complement of planetary gears is used to distribute the load over a large number of gear teeth which, in addition to minimizing the teeth stresses, ensures more even load distribution and increases the actuator stiffness.

The output element of the rotary actuator is radially supported by the fixed housing (F); the radial support occurs along two parallel circular surfaces, symmetrically located at the two sides of the actuator output. Such circular support provides the necessary radial reaction force to balance the force acting on the actuator output, while the moment of the external force about the actuator axis is balanced by the torque provided by the actuator output gear. As a result, the actuator behaves as a powered hinge.

The design of the rotary actuator is such that it can react all torque and shear loads transmitted through the actual hinge created by the actuator. The hinge (shear) reaction force is isolated from the actuator gear teeth by spigotting the fixed ring gears into plain, or roller, bearing recesses in the moveable output ring gears. Because the fixed ring gears are earthed (supported by the structure) all shear loads on the output are transmitted, via the bearings and the fixed rings, to the aircraft structure.

## TYPE 2 GRA CONFIGURATION

Type 2 geared rotary actuators (GRA T2) differ from GRA T1 by the fact that their output is not a ring gear but the shaft (O) of Figure 2 and often the output shaft is hollowed allowing the input shaft (I) to pass through the entire reducer. With reference to Figure 2 the actuator accepts input rotation and torque from the driveline at its input shaft (I). Speed reduction is obtained by means of two integrated epicyclic reducers in series.

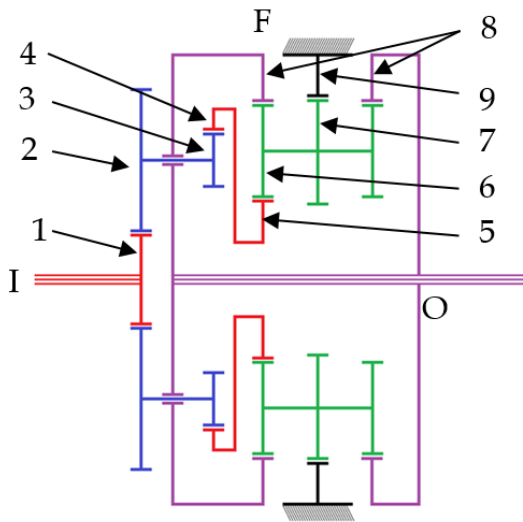

**Figure 2:** Section of a Type 2 geared rotary actuator

The first epicyclic stage, composed by the gears from (1) to (3) and as a planet carrier the internal gear (8), performs the first speed reduction of the component. This stage gear's configuration is similar to the member's arrangement viewed in the standard epicyclics reducers type I and II. As in the more common reducers, the presence of multiple planets allows for a load distribution between the gears permitting greater power transfer in the same form factor when compared with an ordinary gear set. Because the planets are supported by the gear (8) misalignment during operation and manufacturing tolerances require a small downgrade of the maximum load bearable by the gears.

The compound carrierless second stage is composed by the internal to external gear (4) and (5), serving as the input member to the planet assembly constituted by the gears (6) and (7), the supporting gear (9) and the double output gears (8). The compound planetary gear arrangement differs from a conventional epicyclic gear reducer by eliminating the carrier assembly for planetary gears. This is made possible by balancing the tangential teeth forces on the planetary pinions at the ring gear meshes. The compound planetary gearset contains a sun gear (5) receiving the input torque from the internal gear (4), the two ring gears (8) providing the output torque to the driven element (O) and one stationary ring gear (9) placed at the centre of the planets. The power flow from the input to the output sun gears takes place through multiple planet gears meshing with the sun gears. Each planet gear consists of three pinions: the outer end pinion gears (6) are identical, as are the two outer ring gears (8). For each planet the load acting on the two outer gears is reacted by the fixed gear (9)

A full complement of planetary gears is used to distribute the load over a large number of gear teeth which, in addition to minimizing the teeth stresses, ensures more even load distribution and increases the actuator stiffness.

## GENERAL PROPERTIES

As for epicyclic gear reducers, gears rotating about a fixed axis when observed from a static observer are called sun gears, while gears whose axis is not stationary are defined planets underlining their revolving motion around the sun gears. The gears making up the rotary actuators are spur gears which are sized according to the module and the number of teeth. An important feature of the teeth commonly used in the GRA planets is the rounded axial profile. This non-standard geometry accommodates the planets deformation due to the bending moment, thereby ensuring a more uniform load distribution along the teeth length that contributes to reduce localized stress. It is also important to underline that most often the gears of a GRA are cut with a large correction increasing the root thickness permitting higher load transfer in gears with a limited number of teeth.

The speed ratio between output and input of a GRA can be calculated by applying repeatedly the well known Willis equation used for ordinary epicyclic gear reducers

$$r_o = \frac{\omega_n - \omega_p}{\omega_1 - \omega_p} \quad 1$$

To calculate the speed ratio of the GRA T1 two equivalent epicyclic reducers can be identified within a GRA. The first equivalent epicyclic reducer is comprised of gears 1, 2, 4 of **Figure 1**; the second one is comprised of gears 1, 2, 3, 5 of **Figure 1**. These two equivalent epicyclic reducers have their planets carried by the same virtual carrier. When equation 1 and reduction techniques at [1] and [2] are applied to the two equivalent epicyclic reducers, the speed ratio  $r$  for the GRA is eventually obtained:

$$r = \frac{z_2 z_5 / z_3 z_4 - 1}{z_2 z_5 / z_1 z_3 + 1} \quad 2$$

For GRA T2 the application of the Willis equation leads to the total speed ratio given by:

$$r = \frac{1}{1 - \frac{z_2 z_4}{z_1 z_3} \frac{1 + \frac{z_6 z_9}{z_5 z_7}}{1 - \frac{z_6 z_9}{z_7 z_8}} + \frac{z_2 z_4}{z_1 z_3}} \quad 3$$

## GRA inertia

The rotational inertia of the GRA T1 can be computed from the different contributions of all its rotating components. The masses and moments of inertia of the individual components can be computed from the CAD design of the actuator. However, as a first approximation, the inertia of each component can be estimated considering it as a cylinder with diameter equal to the pitch diameter and an uniformly distributed mass. This leads to a slightly overestimated value of the inertia because it does not consider the design features typically introduced to reduce the component mass. With this assumption, the inertia properties of input pinion gear are defined by the following equations:

$$m_{s1} = \frac{\rho \pi}{4} b_1 d_1^2 \quad 4$$

$$I_{si} = \frac{1}{8} m_{s1} d_1^2 \quad 5$$

$$m_{s2} = \frac{\rho\pi}{4} b_2 d_2^2 \quad 6$$

$$m_{s3} = \frac{\rho\pi}{2} b_3 d_3^2 \quad 7$$

$$I_{sp} = \frac{n_s}{8} \left( \frac{z_1 z_3}{z_2 z_5} \right)^2 (m_{sl} d_3^2 + m_{sc} d_2^2) \quad 8$$

Because the motion of the planets is a composition of a rotation about their own axis and a rotation about the axis of the input sun gear, the inertia of the masses of the planets revolving about the GRA fixed axis must be duly taken into account. The inertia of the planets carried in their motion by a virtual carrier is:

$$I_{sc} = \left( \frac{\frac{z_1 z_3}{z_2 z_5}}{1 + \frac{z_1 z_3}{z_2 z_5}} \right)^2 n_s (m_{s2} + m_{s2}) \left( \frac{d_1 + d_2}{2} \right)^2 \quad 9$$

The last contribution to the global inertia of the GRA is given by the output element. This part of the GRA can actually have different shape and mass, depending on its mechanical interface with the driven element. The following equations will thus provide an estimate of the moment of inertia of the output ring gear alone, without considering its flanges or other features that provide the interconnection with the driven element. The error introduced by this approximation is, however, very limited because the inertia of the output element is anyhow very little when reflected to the GRA input shaft because of the very high speed reduction ratio.

$$m_{s4} = \frac{\rho\pi}{4} b_2 ((d_4 + 10m_1)^2 - d_4^2) \quad 10$$

$$I_{so} = \frac{1}{8} r^2 m_{s4} ((d_4 + 10m_1)^2 + d_4^2) \quad 11$$

To moment of inertia of the entire GRA is then obtained by summing all the previously computed contributions of the different parts of the actuator:

$$I = I_{si} + I_{sp} + I_{sc} + I_{so} \quad 12$$

A similar procedure can be applied to calculate the inertia of the GRA T2.

$$m_{g1} = \frac{\rho\pi}{4} b_1 d_1^2 \quad 13$$

$$I_{g1} = \frac{1}{8} m_{g1} d_1^2 \quad 14$$

$$m_{g2} = \frac{\rho\pi}{4} b_2 d_2^2 \quad 15$$

$$I_{g2} = \frac{1}{8} n_{ep} \left( \frac{z_1}{z_2} \right)^2 m_{g2} d_2^2 \quad 16$$

$$m_{g3} = \frac{\rho\pi}{4} b_3 d_3^2 \quad 17$$

$$I_{g3} = \frac{1}{8} n_{ep} \left( \frac{z_1}{z_2} \right)^2 m_{g3} d_3^2 \quad 18$$

Because the planets are carried in their epicyclic motion by the gear (8) the additional rotational inertia is determined via the following equation:

$$I_p = n_{ep} r^2 (m_{g2} + m_{g3}) \left( \frac{d_1 + d_2}{2} \right)^2 \quad 19$$

The inertia of the epicyclic stage is thereby given by:

$$I_{ep} = I_{g1} + I_{g2} + I_{g3} + I_{ep} \quad 20$$

As for the gears (4) and (5) assumption must be made regarding the geometry of the component. Following the guide lines described in the reference document a) the external diameter of the ring gear (4) is assumed equal to the pitch diameter increased by ten times the normal modulus of the gear. Regarding the internal diameter of the hollowed gear (5), this parameter is assumed equal to the pitch diameter decreased by ten times the normal modulus of the gear. The hollow disk connecting the gears (4) and (5) has the inner and outer diameter already defined and we assume its thickness equal to five times the mean of the moduli of the gears (4) and (5).

In order to determine the equivalent inertia at the input axis of the reducer it's necessary to calculate the transmission ratio from the gear (1) to (4). Because of the epicyclic nature of the reducer the angular speed of the planet carrier (8) should be considered, but because the impact on the inertia is small, the transmission ratio is calculated as an ordinary gear train.

By this assumptions the mass and inertia of the gears (4) and (5) plus the connecting disk is:

$$m_{g4} = \frac{\rho\pi}{4} b_4 ((d_4 + 10m_2)^2 - d_4^2) \quad 21$$

$$m_{g5} = \frac{\rho\pi}{4} b_5 (d_5^2 - (d_5 - 10m_3)^2) \quad 22$$

$$m_{d45} = \frac{5}{8} \rho\pi (m_2 + m_2) ((d_4 + 10m_2)^2 - (d_5 - 10m_3)^2) \quad 23$$

$$I_{g4} = \frac{1}{8} m_{g4} ((d_4 + 10m_2)^2 + d_4^2) \quad 24$$

$$I_{g5} = \frac{1}{8} m_{g5} (d_5^2 + (d_5 - 10m_3)^2) \quad 25$$

$$I_{d45} = \frac{1}{8} m_{d45} ((d_4 + 10m_2)^2 + (d_5 - 10m_3)^2) \quad 26$$

$$I_{45} = \left( \frac{z_1 z_3}{z_2 z_4} \right)^2 (I_{g4} + I_{g5} + I_{d45}) \quad 27$$

The planets are composed of two identical lateral gears (6) and a central wheel (7), their contribution to the global actuator inertia is calculated via the following equations:

$$m_{g6} = \frac{\rho\pi}{4} b_6 d_6^2 \quad 28$$

$$m_{g7} = \frac{\rho\pi}{4} b_7 d_7^2 \quad 29$$

$$I_{g6} = \frac{1}{8} m_{g6} d_6^2 \quad 30$$

$$I_{g7} = \frac{1}{8} m_{g7} d_7^2 \quad 31$$

$$I_{cp} = n_{cp} \left( \frac{z_1 z_3 z_5}{2 z_2 z_4 z_6} \right)^2 \left( (2I_{g6} + I_{g7}) + \right. \quad 32$$

$$\left. \frac{1}{(1 + \frac{z_5}{z_6})^2} (2m_{g6} + m_{g7}) \left( \frac{d_8 - d_7}{2} \right)^2 \right)$$

The output gear assembly, composed by the double gear (8) has the following inertia properties:

$$m_{g8} = \frac{\rho\pi}{4} b_8 ((d_8 + 10m_3)^2 - d_8^2) \quad 33$$

$$m_{d8} = \frac{5\rho\pi}{4} m_3 (d_8 + 10m_3)^2 \quad 34$$

$$I_{g8} = \frac{1}{8} r^2 (m_{g8} ((d_8 + 10m_3)^2 + d_8^2) + m_{d8} (d_8 + 10m_3)^2) \quad 35$$

### Stiffness and backlash

For both configuration, when the input shaft of a GRA is held fixed and a load torque is applied at the GRA output in both directions, the angular rotation of the output versus the applied load torque normally has the shape shown in **Figure 3**. The stiffness is defined by the slope of the curve when the load torque is above a low threshold, typically 5% of the rated load. The backlash is defined by the length of the segment on the x-axis determined by the intersections of the straight lines tangent to the curve for loads above threshold with the x-axis.

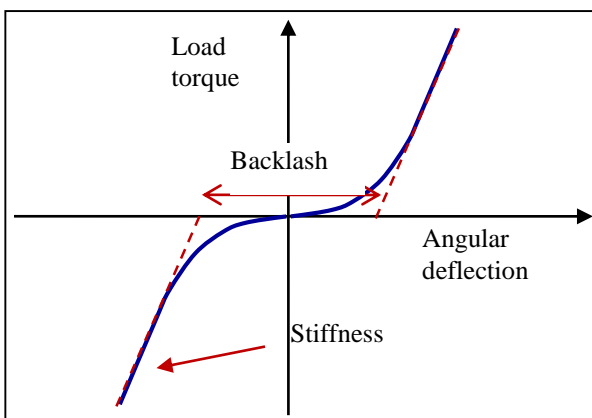

**Figure 3:** Typical curve of angular deflection versus load torque for a geared rotary actuator

Stiffness and backlash of a GRA depend on its specific design characteristics and can be determined once the detailed design of the actuator is finalised. However, the following values for backlash and stiffness referred to the GRA output can be used as a reference as long as the actual values are not known:

$$\text{Angular backlash } \theta_b = 0.08 - 0.15^\circ$$

$$\text{Torsional stiffness: } k_t = (150 - 250) T_{nom} \text{ [Nm/rad]}$$

where  $T_{nom}$  is the rated output torque for the GRA, in Nm, and  $k_t$  the torsional stiffness in Nm/rad referred to the GRA output.

### Power transmission

The mechanical power is ideally transmitted by the component gears from input to output without any internal loss. For this ideal condition, the ratio between output and input torques is inversely proportional to the speed ratio  $r$  defined by equations 2 and 3.

$$\frac{T_4}{T_1} = -\frac{\omega_1}{\omega_4} = -\frac{1}{r} = -\frac{z_2 z_5 / z_3 z_4 - 1}{z_2 z_5 / z_1 z_3 + 1} \quad 36$$

$$\frac{T_8}{T_1} = -\frac{\omega_1}{\omega_8} = -\frac{1}{r} = -\left( 1 - \frac{z_2 z_4}{z_1 z_3} \frac{1 + \frac{z_6 z_9}{z_5 z_7}}{1 - \frac{z_6 z_9}{z_7 z_8}} + \frac{z_2 z_4}{z_1 z_3} \right) \quad 37$$

The geared rotary actuators are mainly designed to provide a large speed reduction ratio with a compact assembly having a large torque-to-weight ratio. This characteristics, however, is obtained at the expense of a reduction of the actuator efficiency; the mechanical power losses must hence be taken into account for a fairly accurate model of this component.

### Power losses

When mechanical power is transmitted through the gears, some mechanical power is lost and converted into heat. Three types of mechanical power losses can be identified:

- Mechanical power losses proportional to the output torque
- Mechanical power losses originated by the gears rotation, that are a function of the gears angular speed
- Parasitic power losses that are not dependent on load or speed, but are generated by a constant drag torque which is anyhow needed to cause a slow speed rotation of the gears in a no-load condition. These are normally referred to as tare losses.

The above mentioned power losses are addressed in the following paragraphs.

### Load dependent mechanical losses

Load dependent mechanical losses are calculated for each gear meshing as in [3], [4] and [5]. The mechanical efficiency of a gear mashing between two spur gears can be calculated

applying equation 38. Where the plus sign must be used if the gears are both external and the minus shall be used if the j-th gear is internal.

$$\eta_{i,j} = \left( 1 - k_f \left( \frac{1}{z_i} \pm \frac{1}{z_j} \right) \right) \quad 38$$

By imposing the torque and power balance for the GRA T1 it is possible to obtain the equations defining the direct ( $\eta_{1,4}$ ) and reverse ( $\eta_{4,1}$ ) efficiencies of the geared rotary actuator:

$$\eta_{1,4} = \frac{\eta_{1,2}\eta_{3,5} \left( 1 - \frac{1}{1 + \frac{z_2 z_5}{z_1 z_3}} \right) + \frac{1}{1 + \frac{z_2 z_5}{z_1 z_3}}}{\eta_{2,4}\eta_{3,5} \left( 1 - \frac{1}{\frac{z_2 z_5}{z_3 z_4} - 1} \right) + \frac{1}{\frac{z_2 z_5}{z_3 z_4} - 1}} \quad 39$$

$$\eta_{4,1} = \frac{\left( 1 - \frac{1}{\frac{z_2 z_5}{z_3 z_4} - 1} \right) \eta_{2,1} + \frac{1}{\frac{z_2 z_5}{z_3 z_4} - 1} \eta_{2,1} \eta_{4,2} \eta_{5,3}}{\left( 1 - \frac{1}{z_1 z_3 + 1} \right) \eta_{4,2} + \frac{1}{z_1 z_3 + 1} \eta_{2,1} \eta_{4,2} \eta_{5,3}} \quad 40$$

Similarly for GRA T2

$$\eta_{1,4} = \left( 1 - k_f \left( \frac{1}{z_1} + \frac{1}{z_2} \right) \right) \left( 1 - k_f \left( \frac{1}{z_3} - \frac{1}{z_4} \right) \right) \quad 41$$

$$\eta_{4,1} = 0.995 \eta_{1,4} \quad 42$$

$$\eta_{6,8} = \frac{\eta_{5,6}\eta_{6,8} \left( 1 - \frac{1}{1 + \frac{z_7 z_8}{z_5 z_6}} \right) + \frac{1}{1 + \frac{z_7 z_8}{z_5 z_6}}}{\eta_{7,9}\eta_{6,8} \left( 1 - \frac{1}{\frac{z_7 z_8}{z_6 z_9} - 1} \right) + \frac{1}{\frac{z_7 z_8}{z_6 z_9} - 1}} \quad 43$$

$$\eta_{8,6} = 0.995 \eta_{6,8} \quad 44$$

$$\eta_d = \eta_{1,4} \eta_{6,8} \quad 45$$

$$\eta_r = \eta_{4,1} \eta_{8,6} \quad 46$$

The use of the reducing coefficient 0.995 is a standard practice to simplify the reverse efficiency calculation and to account for the lower reverse efficiency..

### Speed dependent mechanical losses

Speed dependent mechanical losses are generated by two factors: windage losses developed by the viscosity of fluid entrained by the rotating gears, and micro-impacts occurring at the initial contact of the meshing teeth as the gears rotate. These losses are a non-linear function of the gears angular speed; however, when the actuator runs at the rated speed, the losses are about proportional to the square of the speed and their end effect is to create an opposing torque TS reflected to the pinion axis equal to:

$$T_s = c_s \omega_1^2 \quad 47$$

The coefficient  $c_s$  in the equation above takes into account windage and impact losses and is a function of several factors: gears size, lubricant type, gears profiles quality, temperature.

The speed losses are firstly determined for each rotating gear and then the global speed loss coefficient of the reducer is calculated as function of the speed ratios between gears. For the GRA T1 the sun gears 1 and 4 the speed loss coefficient is calculated as follows:

$$c_{s_i} = k_s d_i^2 \quad 48$$

For the planets, the speed loss coefficient is calculated from the following equation:

$$c_{s_s} = k_s n_s (d_2^2 + 2d_3^2) \quad 49$$

In order to correlate the speed loss coefficient of each gear to the speed of the input shaft, the relevant speed ratios must be utilized. The following expression calculates the global speed loss coefficient of the reducer:

$$c_s = c_{s1} + r^3 c_{s4} + \left( \frac{2z_1}{z_2 + z_3} \right)^3 c_{s_s} \quad 50$$

where  $c_s$  is the speed loss coefficient for complete reducer.

For the GRA T2

$$c_{s_{g1}} = k_s d_1^2 \quad 51$$

For the gear (2) and (3):

$$c_{s_{g2}} = \left( \frac{z_1}{z_2} \right)^3 k_s n_{ep} d_2^2 \quad 52$$

$$c_{s_{g3}} = \left( \frac{z_1}{z_2} \right)^3 k_s n_{ep} d_3^2 \quad 53$$

For the gear (4) and (5):

$$c_{s_{g4}} = \left( \frac{z_1 z_3}{z_2 z_4} \right)^3 k_s d_4^2 \quad 54$$

$$c_{s_{g5}} = \left( \frac{z_1 z_3}{z_2 z_4} \right)^3 k_s d_5^2 \quad 55$$

For the planets composed by the gear (6) and (7):

$$c_{s_{g67}} = \left( \frac{2z_3}{z_6 + z_7} \right)^3 k_s n_c (2d_6^2 + d_7^2) \quad 56$$

And for the gear (8):

$$c_{s_{g8}} = 2|r|^3 k_s d_8^2 \quad 57$$

The global speed loss coefficient of the reducer is:

$$c_s = c_{s_{g1}} + c_{s_{g2}} + c_{s_{g3}} + c_{s_{g4}} + c_{s_{g5}} + c_{s_{g67}} + c_{s_{g8}} \quad 58$$

### Constant mechanical losses

The constant mechanical losses for the GRA that do not depend on either load or speed (tare losses) are originated from several sources. A specific contribution is given by the seals used to contain the lubricant inside the actuator. The tare loss created by the seals in the GRA T1 can be estimated

from the following equation:

$$T_{seal} = K_{s1} d_m d^{2.25} / 1000 \quad 59$$

where,  $K_{s1}$ , is a seal drag coefficient that is normally in the range from 0.015 to 0.020.

The tare loss of the  $i^{th}$  gear can be estimated from the equation 60:

$$T_{TL\ i} = k_{TL} d_i \quad 60$$

Then, the global tare loss reflected to the actuator input shaft is obtained from the following equation:

$$T_{TL} = T_{TL\ si} + \frac{2z_1}{z_2 + z_3} T_{TL\ s} + r(T_{TL\ so} + T_{seal}) \quad 61$$

And for the GRA T2, the tare loss torque of the input pinion is:

$$T_{TL\ g1} = k_{TL} d_1 \quad 62$$

For the gear (2) and (3):

$$T_{TL\ g2} = \frac{z_1}{z_2} n_{ep} k_{TL} d_2 \quad 63$$

$$T_{TL\ g3} = \frac{z_1}{z_2} n_{ep} k_{TL} d_3 \quad 64$$

For the gear (4) and (5):

$$T_{TL\ g4} = \frac{z_1 z_3}{z_2 z_4} k_{TL} d_4 \quad 65$$

$$T_{TL\ g5} = \frac{z_1 z_3}{z_2 z_4} k_{TL} d_5 \quad 66$$

For the planets composed by the gear (6) and (7):

$$T_{TL\ g67} = \frac{2z_3}{z_6 + z_7} k_s n_c (2d_6 + d_7) \quad 67$$

And for the gear (8):

$$T_{TL\ g8} = 2|r|k_s d_8 \quad 68$$

The tare loss torque of the GRA T2 is:

$$T_{TL} = T_{TL\ g1} + T_{TL\ g2} + T_{TL\ g3} + T_{TL\ g4} + T_{TL\ g5} + T_{TL\ g67} + T_{TL\ g8} \quad 69$$

### Torque ratio

The ratio between output and input torques for the ideal case of no mechanical losses, and hence of efficiency equal to 1, is given by equations 36 and 37. When all power losses occurring in a gear drive are taken into account, the relationship between the torques at input and output shafts and the relevant overall efficiencies of the geared rotary actuators

is given in the following paragraphs. The equation are valid for both GRAs architectures.

### Direct power flow

For the prevailing condition of power flow from input to output sun gears, the driving torque  $T_{in}$  necessary at the input shaft to balance a load torque  $T_{out}$  applied to the output element under steady state (constant speed) condition, is:

$$T_{in} = \frac{rT_{out}}{\eta_d} + c_s \omega_1^2 + T_{TL} \quad 70$$

The overall direct efficiency of the reducer is therefore:

$$\eta_{d-GRA} = \frac{rT_{out}}{\frac{rT_{out}}{\eta_d} + c_s \omega_1^2 + T_{TL}} \quad 71$$

### Reverse power flow

When an aiding load condition occurs in the geared rotary actuator and power flows backward from the output to the input, the torque  $T_{in}$  at the input shaft necessary to balance a driving torque  $T_{out}$  applied to the output element under steady state (constant speed) condition, is:

$$T_{in} = rT_{out}\eta_r - c_s \omega_1^2 - T_{TL} \quad 72$$

The resulting overall reverse efficiency of the gear drive is therefore:

$$\eta_{r-GRA} = \frac{rT_{out}\eta_r - c_s \omega_1^2 - T_{TL}}{rT_{out}} \quad 73$$

### Dynamic model

The following paragraphs describe the governing equations of a geared rotary actuator for running and breakout conditions.

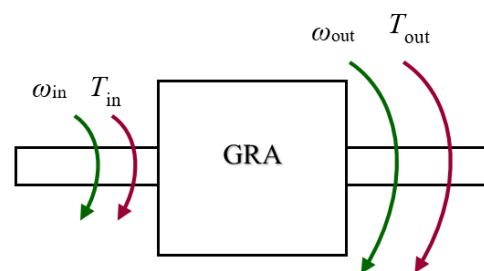

**Figure 4** shows the definition of the positive directions for torque and speed of the GRA input and output gears.

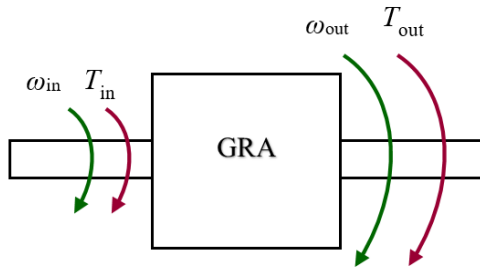

**Figure 4:** Dynamic model of a GRA

The equations representative of GRA dynamics are written reflected to the axis of the input shaft (pinion sun gear). The basic equation defining the gear stage dynamics is then:

$$I \frac{d\omega_{in}}{dt} = T_{in} + rT_{out} - T_{FR} - T_{TL} - T_S \quad 74$$

where  $I$  is the moment of inertia of the GRA reflected to the input shaft.

The torques of the right hand side of 74 include the input and output torques  $T_{in}$  and  $T_{out}$ , the torques function of the load  $T_{FR}$ , the tare losses  $T_{TL}$  and the speed losses  $T_S$ . A proper attention must be given to the load dependent power losses whose contribution was defined in paragraph 3.2.1 as a reduction of the efficiency for the power transmission. The above torque balance equation 74 requires that load dependent power losses be introduced as a torque dissipating mechanical power, as for the speed dependent and tare losses. An equivalent friction torque  $T_{FR}$  reflected to the input axis is therefore defined with the following logic:

If  $T_{out}\omega_{out} < 0$  (hence, the load torque is opposing the motion):

$$T_{FR} = r \left[ T_{out} \left( \frac{1}{\eta_d} - 1 \right) + T_b \right] \text{sign}(\omega_{out}) \quad 75$$

where  $\eta_d$  is the direct efficiency of the GRA and  $T_b$  is the portion of bearing drag torque. Therefore, for this condition if the speed sign is positive, the load torque is negative and the equivalent friction torque is also negative, thereby creating dissipation of mechanical energy.

If  $T_{out}\omega_{out} > 0$  (hence, the load torque is aiding the motion):

$$T_{FR} = -r [T_{out}(1 - \eta_r) + T_b] \text{sign}(\omega_{out}) \quad 76$$

where  $\eta_r$  is the reverse efficiency. Therefore, for this condition if the speed sign is positive, the load torque is also positive but the equivalent friction torque is negative, thereby creating dissipation of mechanical energy.

After defining the equivalent friction torque taking into account the load dependent losses, the governing dynamic equation is:

For the running condition:

$$T_{in} + rT_{out} - T_{FR} - c_s \omega_{in} |\omega_{in}| - T_{TL} \text{sign}(\omega_{in}) = I \frac{d\omega_{in}}{dt} \quad 77$$

When the GRA is initially at rest, the condition necessary to break away and start moving is that the absolute value of the

algebraic sum of external torques  $T_{in}$  and  $rT_{out}$  is greater than the sum of the frictional and drag torques. The following logic equations define the condition necessary for the GRA to start moving

For the breakout condition:

- If  $T_{in} + rT_{out} > 0$  (hence, the sum of the external torques acts in the direction of generating a motion in the positive direction and a positive sign is then assigned to  $\omega_{in}$  and  $\omega_{out}$ ; the frictional torque  $T_{FR}$  is then computed with the applicable of 75 or 76)
- If  $T_{in} + rT_{out} < 0$  (hence, the sum of the external torques acts in the direction of generating a motion in the negative direction and a negative sign is then assigned to  $\omega_{in}$  and  $\omega_{out}$ ; the frictional torque  $T_{FR}$  is then computed with the applicable of 75 or 76)

After having set the sign for  $\omega_{in}$  and  $\omega_{out}$  the condition for the GRA to start moving is given by:

$$|T_{in} + rT_{out} - T_{FR} - c_s \omega_{in} |\omega_{in}| - T_{TL} \text{sign}(\omega_{in})| > 0 \quad 78$$

The remaining case to be addressed is to establish when a condition is reached for the running gears to stop. The numerical integration of the differential equation 74 could in fact lead to a continuous small fluctuation of the GRA angular position around a mean value while the speed fluctuates from positive to negative, without this being an actual behaviour, but simply the result of the numerical solution of the differential equation. An effective way to overcome this potential problem is to apply the reset speed integrator technique when the absolute value of the difference between the active torques and the static passive actions is less than the tare loss torque of the reducer. This technique avoids the continuous fluctuation of the speed value even if the acceleration value is different from zero.

### Design criteria - Minimum teeth number

The number of teeth of a gear cannot go below a minimum value to ensure that the points of contact on the two mating teeth lie on the involute profiles and that no interference occurs. The minimum number of teeth necessary to avoid work interference depends on several geometrical parameters of the gears but can generally be avoided utilizing corrected gears with teeth number greater than 11.

### Design criteria - Maximum number of planets

The multiple planets of a geared rotary actuator allow a sharing of the transmitted torque among the planets, thereby allowing to reach a minimum size of the GRA. Contrary to a conventional epicyclic gear reducer, the carrierless configuration of the GRA allows an almost equal sharing of the transmitted torque among the planets. In general, a non-uniform distribution factor equal to 1.1 is considered in the sizing of the GRA gears.

It is impossible to fit an indiscriminate amount of planets in

the GRA, the number being limited by the space available in the circumferential area separating input and output sun gears. In order to calculate the maximum number of planets, the angle corresponding to 1 revolution must be divided by the angle occupied by the outside circle of a planet. As a result, the maximum number  $n_{s,max}$  of planets is:

$$n_{s,max} = \left\lfloor \frac{\pi}{\text{atan}\left(\frac{z_3+2}{z_3+z_1}\right)} \right\rfloor \quad 79$$

### Design criteria - Load carrying capability

The determination of the load carrying capability of the GRA is a procedure based on the calculation of the maximum torque bearable by the output wheel. This value is then used as output torque to the reducer, having defined its value is now possible to determine the torque acting on each member of the geartrain.

The ability of the geared rotary actuator components to withstand the static and fatigue loads must be computed by a detailed FEM stress analysis, which takes in due account the actual geometry of the gears. Standard gear sizing equation can be used however, since the gears have large corrections and are rounded to account for their deformation, the result can only be approximate.

### CONCLUSIONS

The theoretical framework for the analysis of state-of-the-art geared rotary actuator has been presented along with the equation structure to implement a dynamic simulation of the equipment. This research allowed to develop robust sizing procedure for the GRAs focussed on the system engineering needs rather than a more detailed oriented mechanical design. As such it's main use is for preliminary sizing of rotary actuators.

### NOMENCLATURE

- $r_o$  is the speed ratio of the equivalent ordinary speed reducer
- $r$  is the speed ratio of the reducer
- $\omega_i$  is the angular speed of the i-th gear
- $\omega_p$  is the angular speed of the planet carrier
- $m_{si}$  is the mass of the i-th sun gear
- $\rho$  is density of the material
- $b_i$  is the face width of the i-th gear
- $d_i$  is the pitch diameter of the i-th gear
- $I_{si}$  in the rotational inertia of the i-th sun gear
- $m_{pi}$  is the mass of the i-th planet gear
- $n_s$  is the number of planet

- $I_{sp}$  in the moment of inertia of the planets reflected to the input pinion
- $m_1$  is the modulus of the wheel's teeth
- $\eta_{i,j}$  is the direct efficiency of the gear meshing between the i-th gear and the j-th gear
- $c_{si}$  are the speed loss coefficients for sun gears and planets
- $k_s$  is the speed loss parameter
- $T_{TL}$  is the global tare loss of the reducer
- $T_{TL i}$  is the tare loss of the i-th gear

### REFERENCES

- [1] J. H. Glover Efficiency and speed ratio formulas for planetary gear systems, Product Engineering 27 (1965) pp. 72-79.
- [2] H.W. Muller Epicyclic drive trains: analysis, synthesis and applications, Wayne State University press, 1982.
- [3] G. M. Maitra Handbook of gear design second edition, pp 2.145-2.147.
- [4] R. H. Macmillan Power flow and loss in differential mechanisms Journal of Mechanical Engineering Science, vol. 3, n.1, pp. 37-41.
- [5] G. G. Lucas Expressions governing the power flow through differential mechanisms having imperfect efficiencies, Proc. Institution of Mechanical Engineers, C12/84 Driveline 84 1984.