

Array Elements for LEO SatCom Payloads

Original

Array Elements for LEO SatCom Payloads / Montoya-Roca, Roger; Vazquez-Sogorb, Carlos; Virone, Giuseppe; Addamo, Giuseppe. - ELETTRONICO. - (2023), pp. 453-456. (IEEE Conference on Antenna Measurements and Applications (CAMA) Genoa, Italy 15-17 November 2023) [10.1109/CAMA57522.2023.10352795].

Availability:

This version is available at: 11583/2984906 since: 2024-01-22T08:33:03Z

Publisher:

IEEE

Published

DOI:10.1109/CAMA57522.2023.10352795

Terms of use:

This article is made available under terms and conditions as specified in the corresponding bibliographic description in the repository

Publisher copyright

IEEE postprint/Author's Accepted Manuscript

©2023 IEEE. Personal use of this material is permitted. Permission from IEEE must be obtained for all other uses, in any current or future media, including reprinting/republishing this material for advertising or promotional purposes, creating new collecting works, for resale or lists, or reuse of any copyrighted component of this work in other works.

(Article begins on next page)

Review on HVDC cable terminations

ISSN 2397-7264

Received on 22nd September 2017

Revised 12th March 2018

Accepted on 21st March 2018

E-First on 24th April 2018

doi: 10.1049/hve.2017.0144

www.ietdl.org

Hanyu Ye¹ ✉, Tobias Fechner¹, Xianzhang Lei¹, Yi Luo¹, Mingyu Zhou¹, Zhengyi Han¹, Haitian Wang¹, Qikai Zhuang¹, Ruoyu Xu¹, Duo Li¹

¹Global Energy Interconnection Research Institute Europe GmbH, Markgrafenstr. 34, Berlin, Germany

✉ E-mail: yehanyu.geiri@gmail.com

Abstract: With modern power utilities going green by utilising renewable energy technologies and the development of the smart power grid, high-voltage direct current (HVDC) technologies become more and more important in the energy transmission. In particular, HVDC cable systems play a prominent role in undersea power transmission and offshore renewable energy integration. As an essential part of a complete HVDC cable system, the cable termination is one of the most critical components. The mathematical and physical background of HVDC cable systems is discussed and the development of various types of HVDC cable terminations is reviewed. Regarding the non-uniform field distribution, the influence of temperature on the non-linear conductivity is briefly discussed. Furthermore, faults of terminations caused by inappropriate installation and testing of cable systems are discussed.

1 Introduction

In recent years, the dramatic increasing power demand worldwide and the long-term energy transition towards a reduction of carbon lead to an increasing requirement for long-distance power transmission, interconnection of asynchronous AC grids and integration of renewable energy in the main power networks [1–3]. In this context, high-voltage direct current (HVDC) power transmission becomes more and more competitive compared to high-voltage alternative current (HVAC) power transmission. This is due to several technical and commercial advantages of both HVDC transmission systems using traditional current source converters (CSCs) and HVDC transmission systems using more recently developed voltage source converters (VSCs) [4, 5].

Long-distance power transmission (above 70 km) across the sea and/or offshore wind farms often utilises submarine cables [6]. Overhead lines are cheaper, but underground cable systems are attractive for crossing wide metropolitan areas. Furthermore, underground cable systems also contribute to the general public's aesthetic sensibilities and living environment when compared to overhead lines [7]. For these reasons, HVDC cable systems have become more and more important nowadays.

Unlike HVAC cable systems, the electric field distribution in operation depends not only on the electric field and temperature-dependent electrical conductivity but also on the space charge accumulation in the insulation materials [8]. For this reason, the following aspects should be considered for the development process of HVDC cable systems:

- electrical conductivity which is dependent on temperature and electric field,
- space charge behaviour in insulation materials and at interfaces,
- DC and impulse breakdown strength of cable and accessories,
- Influence of harmonic voltages coming from HVDC converter on PD activity and the lifetime of the cable and accessories [9].

Cable terminations and joints are the least reliable components of a cable system due to the complexity of their electrical, thermal and mechanical design. Furthermore, they consist of many subcomponents assembled in the field, thereby giving rise to the risk of contamination due to pollutants from the environment. Moreover, the reliability of accessories is severely affected by the ability of the installer due to human error [4]. In this paper, the

important background for the development of HVDC cable systems under different conditions is discussed. A brief overview of the design of cable terminations, field grading techniques, designs aspects of stress cones and faults caused by the inappropriate installation is given.

2 Physical background

The electric field distribution in cables and accessories under HVDC can be described by the following equations:

$$\mathbf{E} = -\nabla\varphi \quad (1)$$

$$\mathbf{J} = \kappa\mathbf{E} \quad (2)$$

$$\rho_e = \nabla \cdot (\epsilon_0\epsilon_r\mathbf{E}) \quad (3)$$

$$\nabla \cdot \mathbf{J} = -\frac{\partial\rho_e}{\partial t}, \quad (4)$$

where \mathbf{E} is the electric field, φ is the scalar potential, \mathbf{J} is the current density, κ is the electrical conductivity, ρ_e is the space charge, ϵ_0 is the vacuum permittivity and ϵ_r is the relative permittivity. By a combination of the above equations the following equation can be derived:

$$\rho_e = -\frac{\epsilon_0\epsilon_r}{\kappa}\frac{\partial\rho_e}{\partial t} + \mathbf{J} \cdot \nabla\left(\frac{\epsilon_0\epsilon_r}{\kappa}\right) \quad (5)$$

The electrical conductivity κ of the insulation materials for HVDC cable systems tends to be highly dependent on temperature and to a less extend on electrical field [4]. This dependence is often expressed using the following mathematical formulation [10]:

$$\kappa(T, E) = \kappa_0 \cdot e^{(\alpha(T-T_0) + \beta(E-E_0))}, \quad (6)$$

where κ_0 is the electrical conductivity at the reference stress E_0 and the reference temperature T_0 , α and β are the temperature and electric field coefficients, respectively.

Alternatively, the electrical conductivity can analytically be described by the following equation [11]:

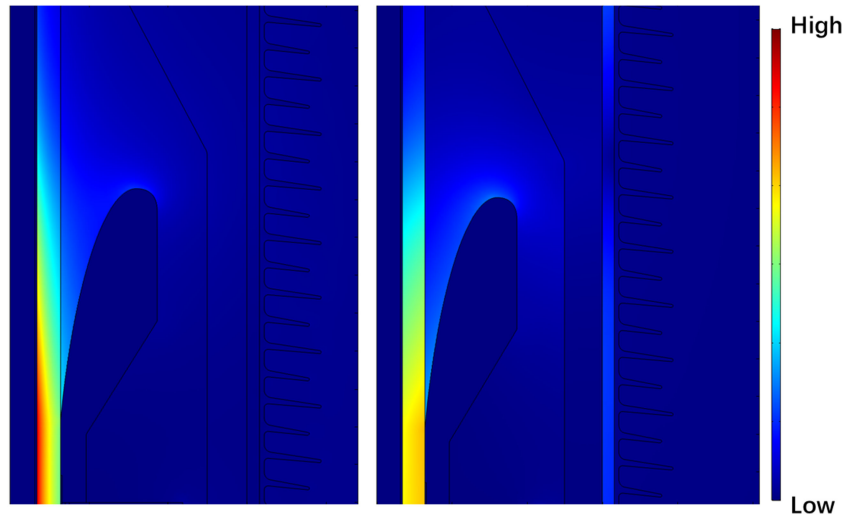

Fig. 1 Electric field distributions in a cable termination. Left: capacitive field distribution; right: resistive field distribution

$$\kappa(T, E) = A \cdot e^{(-\phi - q/k_B \cdot T)} \cdot \frac{\sinh(B \cdot E)}{E}, \quad (7)$$

where A and B are the material constants, ϕ is the thermal activation energy in eV, q is elementary charge, T is temperature in Kelvins and k_B is the Boltzmann constant.

To obtain the electric field distribution in the cable systems, the temperature distribution should be known. This can be done by solving the following heat conduction equation:

$$\rho_m \cdot C_p \frac{\partial T}{\partial t} = \nabla \cdot (\lambda \cdot \nabla T) + S_{\text{heat}}, \quad (8)$$

where ρ_m is the mass density, C_p is the specific heat capacity and λ is the thermal conductivity. The source term S_{heat} represents the resistive losses in the conductor and in the insulation materials. The losses in the insulation and in the conductor are given by the following equations:

$$S_{\text{heat, insulation}} = \kappa \cdot E^2 \quad (9)$$

$$S_{\text{heat, conductor}} = I^2 \cdot R, \quad (10)$$

in which I is the current flowing through the conductor and R is the resistance of the conductor.

During operation, HVDC cable systems will undergo several different operational stages which, due to the complex nature of dielectrics, will result in varying field stress. Shortly after increasing the voltage, the distribution of the electric field is capacitive graded and mainly determined by the permittivity of the insulation materials:

$$\nabla \cdot (\epsilon_0 \epsilon_r \mathbf{E}) = 0 \quad (11)$$

Thereafter, the transition from capacitive to resistive field takes place. In this stage, the electric field distribution is time dependent, which is governed in (1)–(4). After a sufficient amount of time equal to 10τ [4] has passed, the field reaches the steady-resistive state and becomes time invariant. At this stage, the following equations can be used for the calculation:

$$\nabla \cdot (\kappa(T, E) \cdot \mathbf{E}) = 0 \quad (12)$$

$$\nabla \cdot (\lambda \cdot \nabla T) + S_{\text{heat}} = 0. \quad (13)$$

In Fig. 1, the capacitive field and resistive field distributions in a cable termination are illustrated, showing a completely different field stress in the cable insulation, as well as slight changes in the regions under the deflector, at the tip of the deflector and at the housing.

For CSC systems, a reversal of the power flow direction is accomplished by inverting the voltage polarity. Immediately after the polarity reversal, the electric field can be calculated as follows:

$$E(t = 0^+) = E(t = 0^-) - 2E_{\text{capacitive}}, \quad (14)$$

where $E(t = 0^+)$ is the electric field just after the polarity reversal and $E(t = 0^-)$ is the electric field just prior to it. $E_{\text{capacitive}}$ is the capacitive electric field given by the following equation:

$$\nabla \cdot (\epsilon \cdot \mathbf{E}) = 0, \quad (15)$$

where ϵ is the permittivity of insulation material.

In VSC systems, a voltage polarity reversal is not required, because the power flow direction is inverted by reversal of the current flow direction.

In addition, HVDC cable systems in operation will experience stress by switching overvoltage and, in case of DC links with overhead line sections, lightning overvoltage. In this case, the impulses are superimposed onto the DC operating voltage. Suppose the peak value of the superimposed voltage is U_P and the DC operating voltage is U_{DC} , then the superimposed electric field $E_{\text{superimpose}}$ can be divided into two parts as follows:

$$E_{\text{superimpose}} = E_{DC} + E_{\text{impulse}}, \quad (16)$$

where E_{DC} is the steady resistive DC field at operating voltage U_{DC} and E_{impulse} is the capacitive field of the applied impulse voltage $U_P - U_{DC}$. These two parts can be determined separately. More information about how to numerically calculate the electric field distribution at various stages can be found in [12].

3 Operational stages of HVDC cable termination

To design a reliable HVDC cable termination, the electric field and temperature distribution should be estimated and optimised under all operating conditions. These include the following sections.

3.1 DC operation

The electric field distribution under the DC operation is determined by the conductivities of the insulation materials, which are strongly affected by the temperature. Special attention should be paid to the tangential electric field along the interface between the cable insulation material and the stress cone. In case of varying load current, the temperature distribution will change and hence the conductivity will change depending on the location. Since the insulation materials of the cable and of the stress cone often have different temperature dependencies, a varying load current may lead to a shift of the location with maximum field strength. Fig. 2

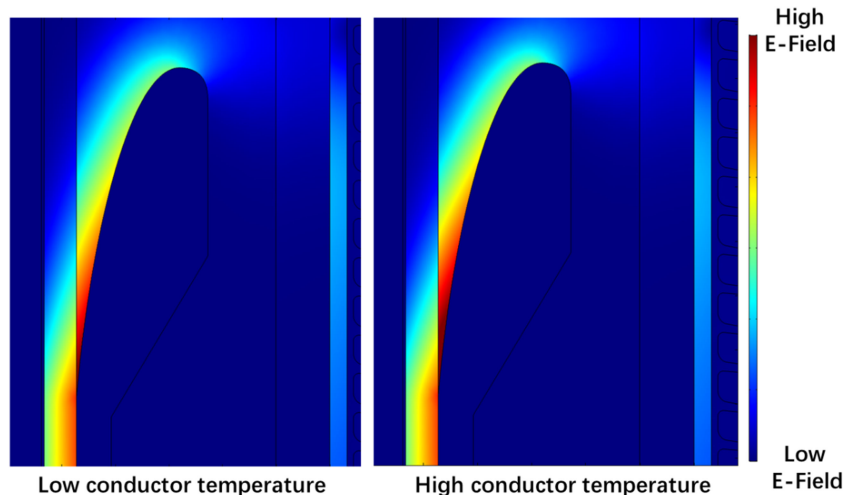

Fig. 2 Electric field distributions in a cable termination. Left: with low conductor temperature; right: with high conductor temperature

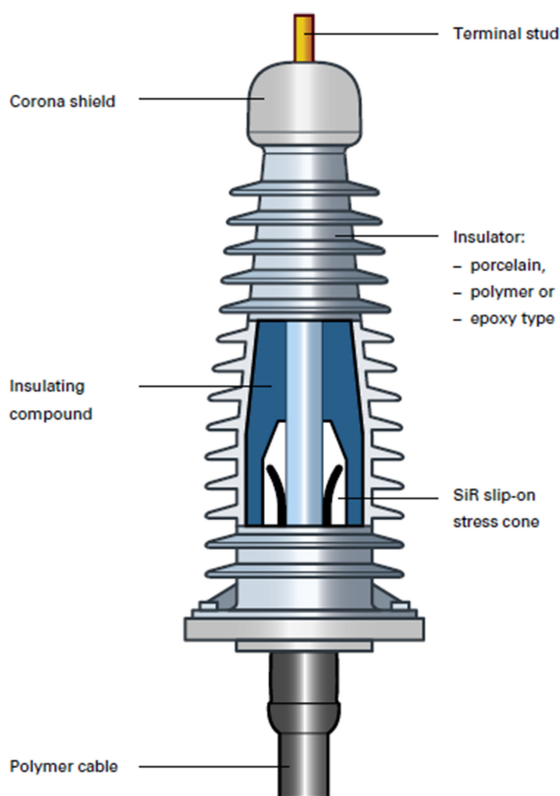

Fig. 3 Typical design of an outdoor termination for polymeric cable [13]

shows the difference of electric field distributions in an HVDC cable termination under different conductor temperatures. In this case, the region of critical field stress under the deflector expands at higher temperature.

3.2 Polarity reversal

For CSC systems with thyristor valves, the direct current is always flowing in the same direction. A reversal of the power flow direction can only be achieved by the reversal of the voltage polarity. As in the case for cables, for the termination a voltage polarity reversal leads to a significant increase of the electric field close to the inner conductor, especially if the cable is operated at high temperature. For VSC systems, this effect is not considered since the voltage polarity is not reversed.

3.3 Transient conditions

Under transient conditions, i.e. impulse or switching voltages, the capacitive electric field can only be graded by capacitive grading

methods or by non-linear field grading materials. Using the latter one, HVDC cable terminations can be designed more compact.

4 HVDC cable termination design

Cable terminations are devices which connect the cable to an external device, such as transmission lines (outdoor termination) and gas insulated switchgears (gas insulated switchgear (GIS) termination). In this section, the basic design of several types of terminations is introduced.

4.1 Outdoor termination

The basic design of an outdoor cable termination is given in Fig. 3. It consists of the following components:

- A hollow insulator: this can be made of porcelain or elastomeric materials such as silicone rubber or ethylene propylene rubber. For the elastomeric housing, a load-bearing insulating tube made of resin-impregnated fibres and metal fixing devices at the ends of the insulating tube are required
- A stress cone with deflector which ensures the geometric-capacitive field control between the outer semiconducting layer and the insulation
- An insulating compound to further degrade the electric field strength. Silicone oil and SF₆ gas are the most used compounds, particularly silicone oil, which is by far the more popular one.
- A corona shield, to prevent corona discharges in air at the top edge of the bushing
- A terminal stud, for connecting the cable to an external device

In addition to the issue of voltage level, conductor cross-section and the choice between porcelain and composite insulator, the creepage distance is also one of the most relevant parameters for an outdoor termination [14]. To determine the appropriate creepage distance for a termination, the pollution severity at the installation site of the termination must be known. Then the reference unified specific creepage distance (RUSCD) can be determined. The standard IEC 60815-1 [15] defines five different pollution classes under AC according to their degree of severity and the corresponding minimal required RUSCD. The standard IEC 60815-4 [16] gives the first approach for the determination of the required DC-RUSCD for insulators with respect to pollution.

4.2 GIS terminations

Terminations for HVDC extruded cables can also be designed to connect to a GIS. The typical design for a GIS termination is shown in Fig. 4. The outer insulator is made of epoxy resin. The space between the cable with its stress cone and epoxy resin insulator is filled with some dielectric fluid or gas such as oil of and SF₆. The connection from the GIS to the termination under AC

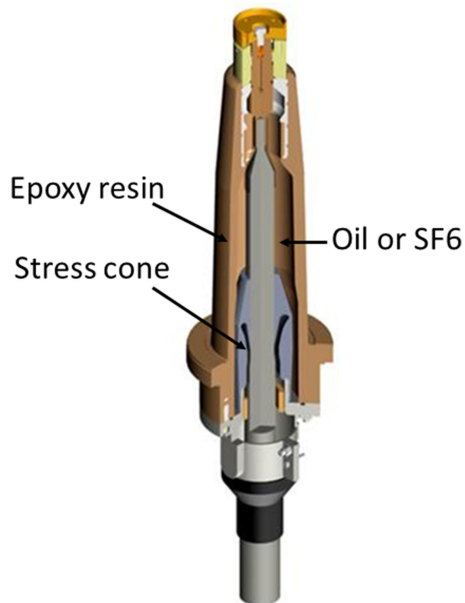

Fig. 4 Cross-section of a GIS termination (source: G&W Electric)

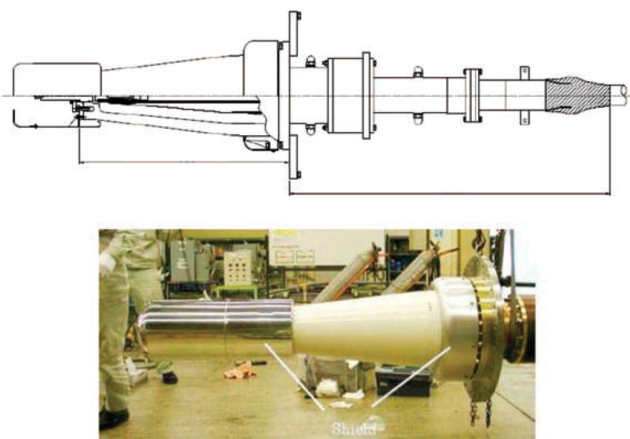

Fig. 5 GIS termination of the condenser cone type for ± 320 kV, 500 mm^2 HVDC extruded cable, intended for use in both land and undersea cables [4]

is standardised in the IEC 62271-209 [17] and EN 50299 [18]. The main advantage of this termination is that it can be easily adapted to various cable constructions and dimensions without problems. This is, because the space between the cable and epoxy insulator is filled with fluid. Hence, this kind of design is particularly suitable for applications on site where the actual dimension of the cables can significantly differ from the design specification [13]. One disadvantage of this design is the use of the fluid insulation median, requiring a very careful sealing of the termination to avoid any leakage that could lead to an electrical breakdown [19]. The most critical position is the interface between the cable and the termination base plate. At this position, the sealing should be accomplished perfectly to avoid fluid leaks. Hence, for extra high-voltage terminations, a monitoring system is required to detect leakage.

A GIS termination of the condenser cone type for ± 320 kV HVDC extruded cable, developed by VISCAS, is shown in Fig. 5. For this design, the main insulation consists of the condenser type insulation made of layers of paper impregnated with silicone oil, an epoxy bushing and SF₆ gas immersed in the GIS case [4].

4.3 Dry type plug-in termination

The design of dry type plug-in terminations connected to SF₆ filled GIS and transformers is very similar (see Fig. 6). Just like the classic terminations, the difference is that the transformer

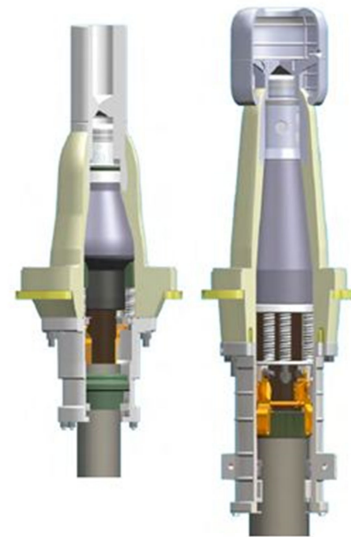

Fig. 6 Dry type plug-in cable termination for GIS (left) and transformer (right) (Source: NKT)

terminations are usually configured with a corona shield. This plug-in system consists of two parts: (i) a socket made of epoxy resin (often called ‘female part’). This part can be directly delivered to the GIS manufacture and can be connected to the GIS in the factory or on site; (ii) the plug, which is also called ‘male part’, which consists of the pre-moulded silicone stress cone for the electric field control, the connection bolt, the cable gland and the spring system.

The interface between the epoxy resin and the silicone stress cone is usually the weak point of this design. To ensure sufficient dielectric strength at the interface, a certain contact pressure at this interface must be guaranteed. This can be realised by a spring system.

4.4 Termination featuring non-linear field-grading material

To homogenise the tangential electric field along the interface between the cable and the stress cone of the termination, ABB proposed to use a continuous layer of the non-linear field grading materials, which connects the live electrode to the ground. For this design, the non-linear resistive field grading method is adopted, which will be introduced in Section 5. Fig. 7 shows an illustration of a ± 320 kV extruded cable termination featuring the field grading materials. ABB also applied this non-linear field-grading material in HVDC cable terminations and joints for higher voltage levels.

5 Field grading methods

The essential component of a cable termination is the stress cone. It plays a key role in grading the electric field along the interface between the cable insulation and the stress cone. In this section, various field grading methods are listed and discussed.

To connect a cable to a termination the outer semiconducting layer of the cable must be removed. Without any field grading technique, a very high electric field occurs at the edge of the semiconducting layer, as shown in Fig. 8, leading to partial discharges and finally to a breakdown.

To maintain an acceptable distribution of the electric field under all operating conditions, especially along the interfaces between different components of the termination, field grading techniques should be adopted. These can be divided into two main classes:

- Capacitive field grading, which includes geometrical electrode grading, permittivity grading and condenser grading.
- Resistive field grading, which includes resistive grading and non-linear field grading.

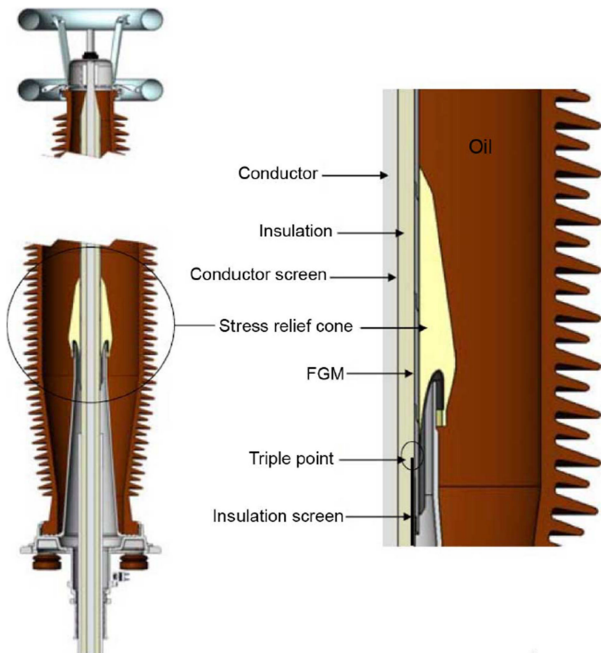

Fig. 7 Schematic view of the extruded HVDC cable termination with field grading materials [20]

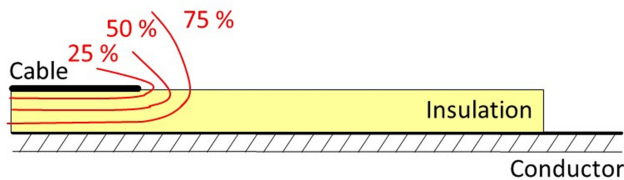

Fig. 8 Schematic view of equipotential lines of the cable end without any field grading method

For HVDC cable terminations, the electric field is resistively graded under steady-state operation when different dielectrics are involved. For transient conditions, i.e. under impulse or switching voltage, the electric field can be either capacitively graded or graded by non-linear field grading materials. A brief overview about the field grading techniques for cable terminations is given in the following section.

5.1 Geometrical electrode grading

This type of field grading is the most frequently used field control method for polymer cable accessories and the most important to grade the electric field in case of transient. This method is based on the geometrical shaping of the electrodes, in case of cable accessories, so-called deflectors made of semiconducting materials (Fig. 9). The ground potential of the cable shield is guided outwards by the contour of the deflector. The electric field strength can be decreased significantly along the contour from the cable surface outwards when the curvature of the deflector is sufficient large. This principle is similar to a Rogowski profile [21]. The geometrical field grading can be applied to all kinds of the voltages. However, this method requires huge volumes, therefore leading to designs with large dimensions and diameters. Hence, some manufacturers search for alternative methods, such as non-linear resistive field grading [22, 23].

5.2 Condenser field grading

This method is also called capacitive field grading. A condenser field grading can be achieved by using conductive grading layers between ground and high-voltage potential, see Fig. 9. These conductive grading layers act as electrodes and can be seen to have floating potential, similar to capacitive voltage dividers, leading to a uniform distribution of the voltages in the axial direction. This method is mainly used for accessories of oil-filled cables or high-

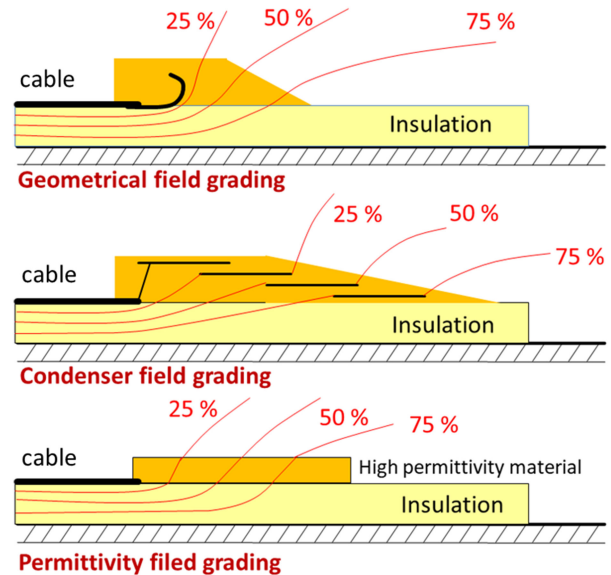

Fig. 9 Schematic view of equipotential lines of the cable end with different capacitive field grading methods [21]

voltage bushings up to the highest voltages [24]. Basically, this field grading method can be applied not only to AC and surge voltage but also to DC voltage. However, for DC voltage, the voltages between the conductive grading layers are determined by the resistance between them.

5.3 Permittivity grading

Permittivity field grading, also called refractive field grading, is a method using high permittivity materials, see Fig. 9. By means of field refraction and field displacement, the equipotential lines are displaced away from the edge of the semiconducting layer of the cable. In this case, the maximum electric field can be reduced. By using this field grading method, the product can be compactly designed and does not cause additional ohmic losses. However, permittivity grading can only be used for time-varying voltages (AC or impulse) and it is not effective for DC voltage.

5.4 Resistive grading

For the resistive field grading, a semi-conductive material is applied to the surface of the cable insulation material, as shown in Fig. 10. In case of AC voltage and impulse voltages, the axial resistances and the radial capacitances relative to the inner conductor form an RC lattice network. In case of DC voltage, the radial capacitance does not play a role for the field grading. The electric field can be controlled just by the resistance of the semi-conductive material on the surface. A major advantage of the resistive field grading is that only a very thin layer of a semi-conductive material is required. As a result, the volume required for this type of field grading is extremely low. Disadvantages are the frequency dependence of this method, the temperature-dependence of the conductivity and the difficulty of setting defined conductivities. Besides, great care should be taken to avoid local overheating due to too high conductivity.

5.5 Non-linear grading

A non-linear field grading is achieved by using non-linear field functionally grading materials (FGM), which can be considered as variable resistors, see Fig. 11. These materials usually have low conductivity at low electric fields and become significantly conductive if the electric field exceeds the certain value, which is also called the switching point. Thereby, the locally enhanced electric field can be reduced. For these materials, fillers such as silicon carbide (SiC), doped ZnO particles (so-called microvaristor) and iron oxide (FeO) are embedded in a polymeric matrix material such as polyethylene, epoxy resin or silicone rubber, in which the percolation threshold must be exceeded to

allow continuous conductive paths. The classical applications of non-linear field grading materials are cable accessories for medium voltage [25, 26], stator winding insulation in generators and in big motors [27] as well as 550 kV compact GIS bushings [28].

The conductivities of a non-linear resistive field grading material should be tuned according to regions that are determined by the electric design field, required for the expected electric field strength in high-voltage devices, e.g. nominal field strength, surge, pulse conditions, leakage current as well as heating conditions, see Fig. 12 [29]. Fig. 13 shows the dependence of electric field

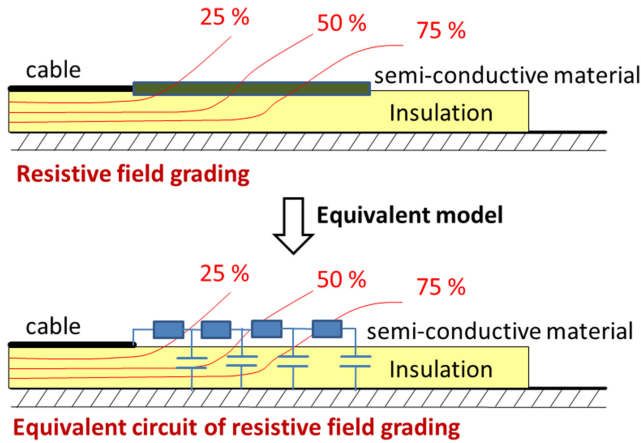

Fig. 10 Schematic view of equipotential lines of the cable end with resistive field grading methods

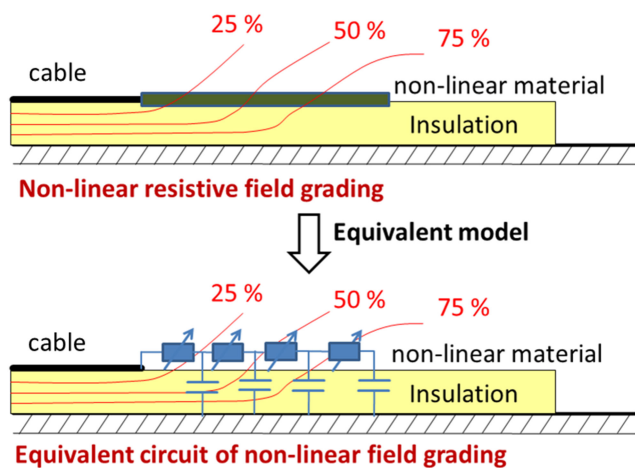

Fig. 11 Schematic view of equipotential lines of the cable end with non-linear resistive field grading methods

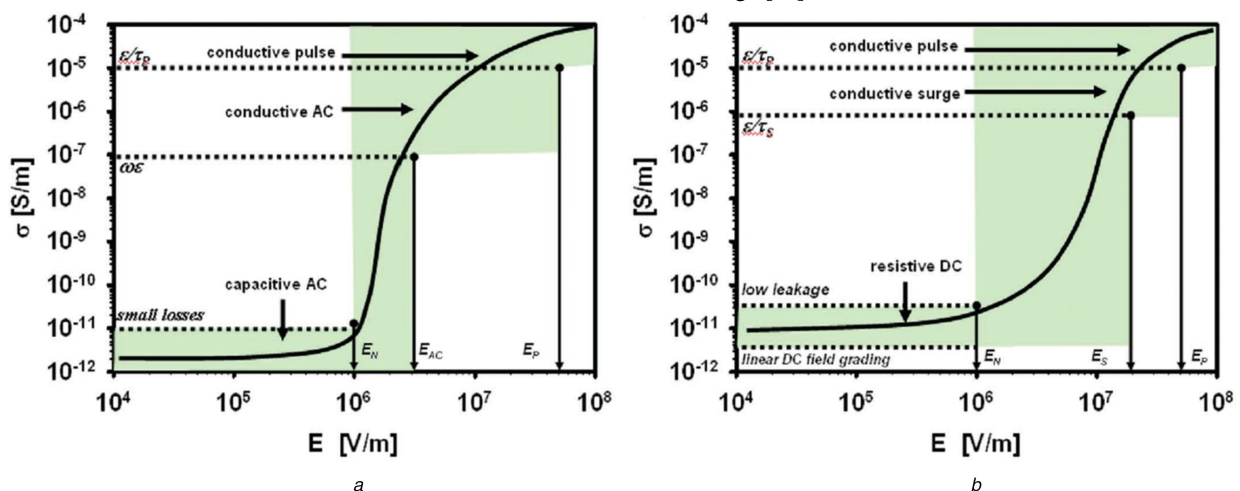

Fig. 12 Qualitative illustration sketch of how regions are determined in the $E - \sigma$ plane for the $\sigma(E)$ of an ideal non-linear resistive field grading material (a) AC applications, (b) DC applications [23]

distributions of the cable end on the temperature. The electric field distributions along the interface of a geometric graded cable end change dramatically under different current-load cases. Consequently, a product using geometric field grading method should be designed for the worst case of all possible operational stages. In contrast, the electric field distributions can be well homogenised via non-linear FGM and are much more robust under different temperatures. Therefore, using non-linear FGM makes it possible to design products more compact than products using geometrical field grading method [20, 29]. However, know-how in the area of non-linear FGM is a prerequisite for the proper design and application of FGM to HVDC products, which still represents a big challenge in itself [29]. More information about the non-linear FGM can be found in [23, 30].

6 Aspects of stress cone design

The most important part of an HVDC cable termination is the stress cone. The stress cone consists of a semi-conductive deflector and an insulation body made of elastomers, such as silicone rubber (SiR) or ethylene propylene diene monomer (EPDM). In this section, the structural design of the deflector and the selection of insulation materials regarding the interfacial behaviours are discussed.

6.1 Structural design

Deflectors have a dominant impact for field grading under transient conditions. The deflector is made of semi-conductive material and its contour serves to homogenise the electric field distribution. Finite-element-method (FEM) simulations are a useful tool to

optimise the contour of the deflector at a low cost. For this optimisation of the geometrical parameters, as shown in Fig. 14, the electric field inside the insulation body and along the interface between the cable insulation and the stress cone insulation should be under a threshold value, which is proven to be reliable based on long-term experience [31].

A stress cone is installed on a cable with an expansion to generate a sufficient surface contact pressure. In this case, the stress cone loses its original shape while being expanded. Consequently, the wall thickness of the stress cone reduced, and the deformation changes the contour of the deflector surface, as demonstrated in Fig. 15. This means that the installed stress cone may perform worse than predicted by the simulation. To avoid this problem, the stress cone should be designed considering effects related to deformation. One approach is to design the contour of the deflector under the expanded condition to get the optimal electric field distribution. Then using the mechanical FEM-simulation to calculate the original shape of the stress cone and the deflector before the expansion, whose dimensions are used for the mode design [33].

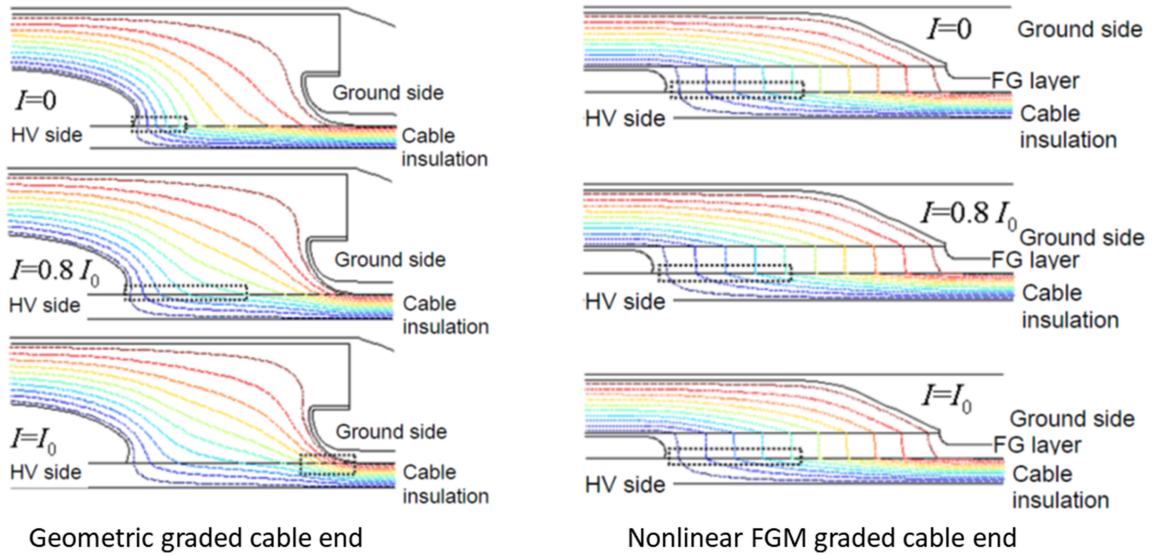

Fig. 13 DC equipotential lines of the cable end for three different current-load cases. The dashed box shows the region for 50% voltage drop along the interface [29]

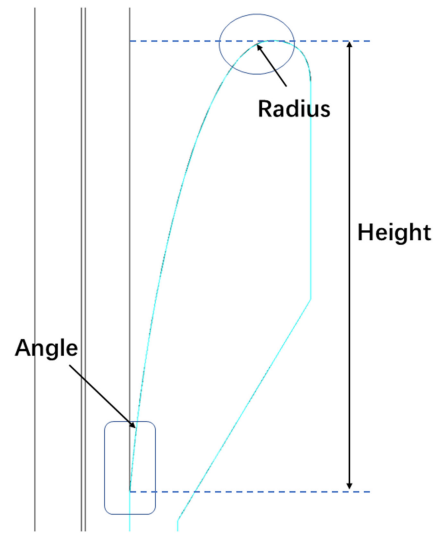

Fig. 14 Some essential geometrical parameters for the optimisation of the deflector

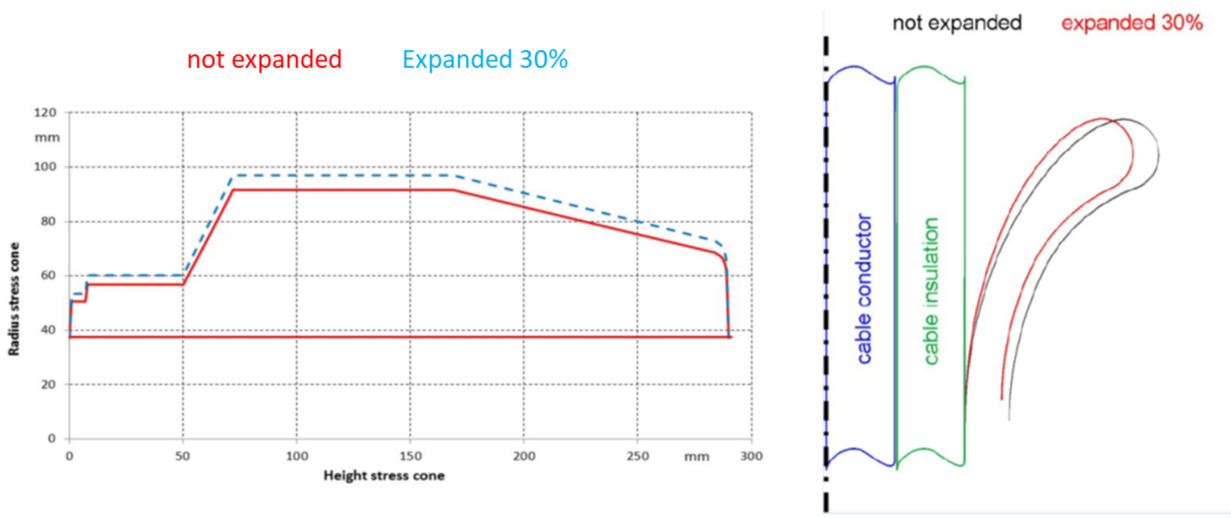

Fig. 15 Illustration of the deformation of a stress cone and a deflector with and without expansion [32]

6.2 Selection of insulation material

Another major issue in the design of a stress cone is the selection of insulation material. One of the most important points is related to charge dynamics at the interface between the cable insulation

and the stress cone materials. Assuming that no charge injection occurs, the surface charge $\rho(t)$ at the interface can be modelled using the Maxwell–Wagner–Sillars (MWS) expression [34, 35]:

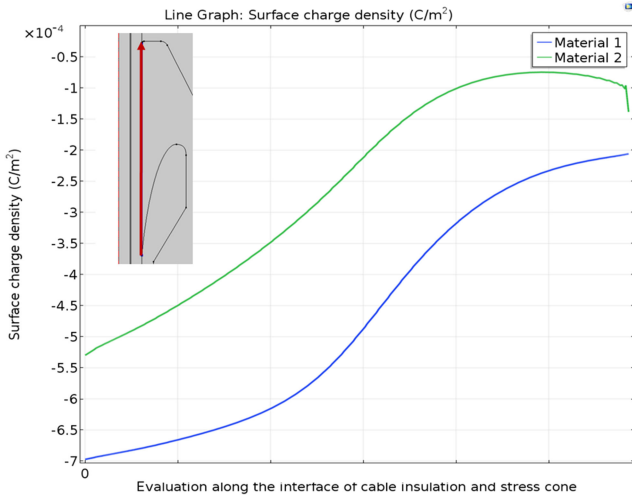

Fig. 16 Surface charge distributions along the interface of cable insulation and stress cone in an HVDC termination with two different materials for the stress cone. The evaluation was carried out from the root of deflector to the top of stress cone

$$\rho(t) = \frac{\varepsilon_A \kappa_B - \varepsilon_B \kappa_A}{\kappa_A d_B + \kappa_B d_A} U_0 \left(1 - \exp\left(-\frac{t}{\tau_{MWS}}\right) \right), \quad (17)$$

where ε_A and ε_B are the permittivities of the dielectrics A and B ; κ_A and κ_B are the respective conductivities; d_A and d_B are the thickness; U_0 is the applied voltage across the dielectrics, and the polarisation time constant is given as

$$\tau_{MWS} = \frac{d_A \varepsilon_B + d_B \varepsilon_A}{d_A \kappa_B + d_B \kappa_A}. \quad (18)$$

This indicates that the amount of the accumulated charge at the interface is proportional to the change of the permittivity/conductivity ratios in two dielectrics. Obviously, this ratio is strongly dependent on temperature due to the dependence of conductivity on temperature. To optimise the tangential electric field along the interface between the cable insulation and the stress cone, the insulation material for the stress cone should be carefully selected and tuned. From (17), it can be concluded that the higher the difference in terms of conductivity and permittivity for the two dielectrics is, the larger the amount of the surface charge along the interface will be. For this reason, the cable insulation material and the insulation material for the stress cone should have, as much as possible, similar conductivity values [36]. In Fig. 16, surface charge distributions along the interface of cable insulation and stress cone in an HVDC cable termination are shown. For this simulation, the same permittivity was assigned to materials 1 and 2, but the conductivity of material 2 was chosen more similar to cross-linked polyethylene (XLPE) than that of material 1. As can be seen in Fig. 16, this results in less surface charges along the interface. However, it is very difficult to accomplish similar conductivity values in the whole operating temperature range, since the cable insulation material (usually XLPE) has a stronger temperature dependence than the insulation material of the stress cone, i.e. SiR or EPDM.

Another point is that a careful matching of insulation materials of cable and stress cone and a reduction of the temperature dependence of the conductivity of cable insulation will lead to a better design. This effect is demonstrated in Fig. 17 for two different cable insulation materials. XLPE 1 has a lower temperature dependence of conductivity than XLPE 2, leading to a better electric field distribution in the stress cone. Furthermore, the design will benefit significantly from an increase in the thermal conductivity of the insulation materials. This is because, on the one hand, it will lead to a reduction of the temperature gradient in the insulation material, resulting in a more uniform electric field distribution. On the other hand, it will reduce the probability of thermal instability.

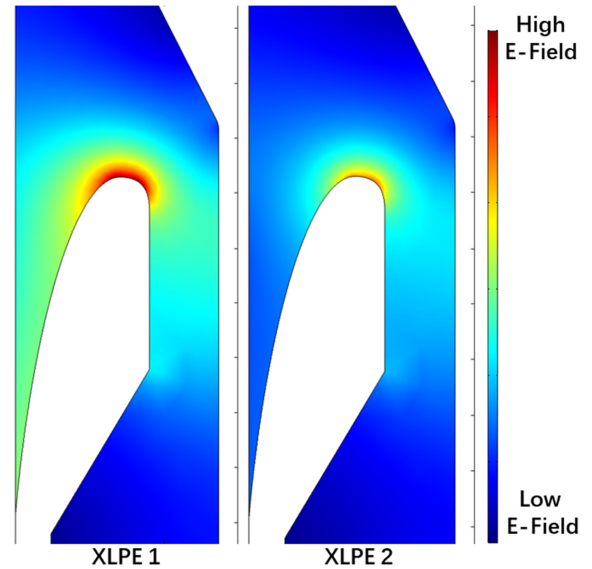

Fig. 17 Electric field distributions in the stress cone of an HVDC termination for different cable insulation materials (XLPE1 and XLPE2)

7 Installation of cable terminations

Beside the careful design of cable terminations, the high-quality installation process is also an essential part for the reliable operation of a cable termination. Failures during the installation, even tiny inclusions of dust or dirt or small cable bending, can distort the electric field, leading to dielectric breakdown at the weak points [37]. According to the data collected by China Southern Power Grid, 85.5% failures are caused by cable accessories, as shown in Fig. 18. A total of 49.33% of these failures were caused by inappropriate installation. The main problems occurring during the installation are summarised as follows [38, 39]:

- incorrect installation location,
- improper cable preparation, such as rough surface and uncleanliness on the surface,
- carbon-black left on the interface while moving the stress cone,
- insufficient straightening of the cables,
- excessive pre-expansion leading to the damage of stress cone.

Since cable system failure is often caused by improper installation, great attention must be given to the installation process. To ensure reliability of cable systems it is essential the following points are addressed [40]:

- qualified and well-trained installer,
- clear, accurate and well-defined installation instructions,
- cleanliness on site,
- terminations should be designed to allow for mechanical loads.

Although there are several types of terminations, the general steps for the installation are similar for each type. The main steps can be summarised as shown in Fig. 19.

8 Testing of HVDC cable termination

Cable terminations are usually tested together with cable and joints as a system. For the test of HVDC cable systems up to ± 320 kV, the IEC standard 62895 [41] is applied. Up to 500 kV, the testing can be done according to the recommendations in the Cigré Technical Brochure (TB) 496 [42] issued in 2012, which replaces the TB 219 [43].

8.1 Tests according to Cigré TB 496

For the testing of high-voltage DC extruded cable systems, Cigré proposes the following types of tests in the TB496:

- development tests (tests made by the manufacturer during the development, regarding material properties and behaviour, field distribution for operational conditions, ageing and long-term stability, influence of production variations on field distribution);
- prequalification test (test for demonstration of long-term performance);

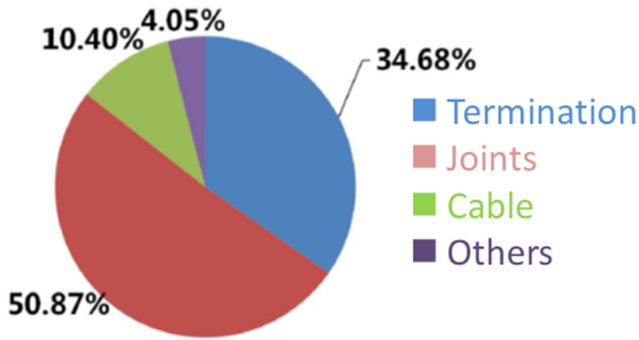

Fig. 18 Statistical distributions of failures caused by different components of 110–220 kV cable systems. (Damages caused by the external force have not been considered here.) [38]

- type test (test for demonstration of satisfactory performance of a specific design);
- routine tests (tests on manufactured cable system components to check if specified requirements are met);
- sample tests (tests made on samples from cable system components or components of cable or accessories to check if specified requirements are met at a certain frequency);
- after-installation tests (tests to verify the integrity of installed cable system).

Terminations have to be tested as components of a full cable system, consisting of a cable and all types of accessories like shown in Fig. 20. As can be seen, 0.5 m of cable is defined to be part of an accessory under test. As type tests and prequalification tests are necessary in terms of supplying terminations as part of a cable system on a commercial basis, only these tests are introduced in more detail.

For a prequalification test at least 100 m of cable and all accessories have to be used in a test loop that is assembled and installed under normal field conditions using the manufactures instructions. The test loop has to undergo a long-duration voltage test for a minimum of 360 days, as well as a superimposed impulse voltage test followed by an examination. Depending on the application of the system, sequences for line-commutated-

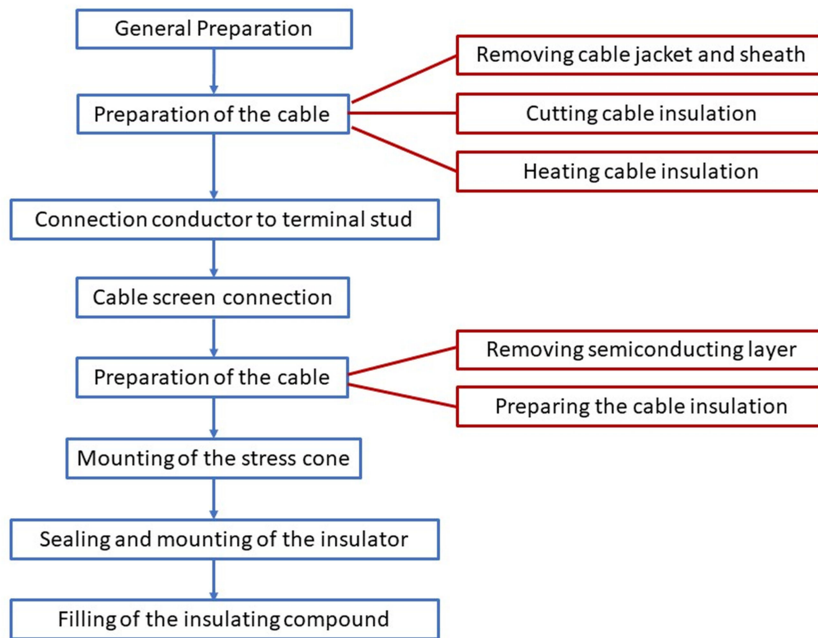

Fig. 19 Diagram of general steps for the termination installation process

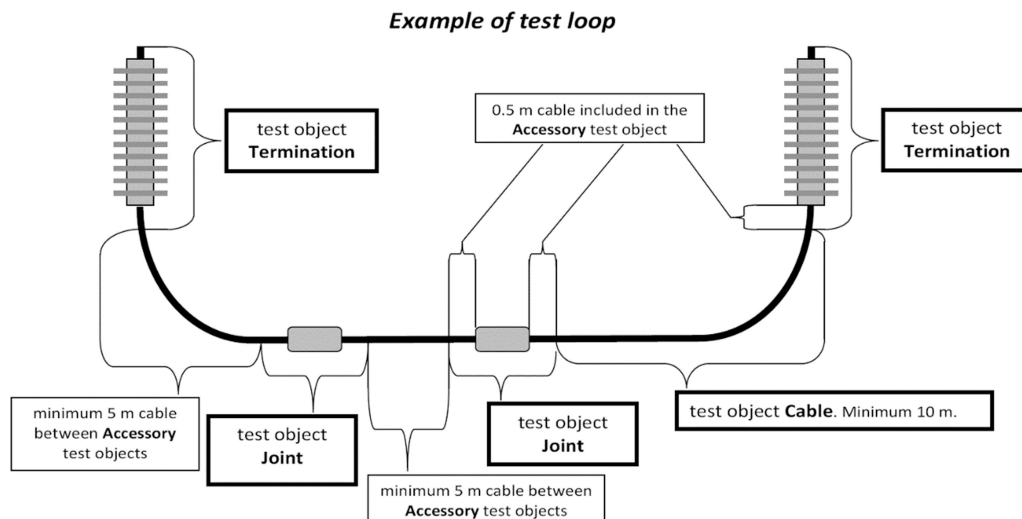

Fig. 20 Example of test loop configuration [42]

Line commutated converter, LCC

	LC	LC	LC+PR	HL	HL	ZL	LC	LC	LC+PR	S/IMP
Number of cycles or days	30 cycles	30 cycles	20 cycles	40 days	40 days	120 days	30 cycles	30 cycles	20 cycles	Not applicable
Test Voltage	+	-		+	-	-	+	-		$U_{P2,0} = 1.2 \times U_0$ $U_{P1} = 2.1 \times U_0^*$
	U_{TP1}	U_{TP1}	U_{TP2}	U_{TP1}	U_{TP1}	U_{TP1}	U_{TP1}	U_{TP1}	U_{TP2}	

LC=Load Cycle, HL=High Load, PR=Polarity Reversal, ZL=Zero Load, S/IMP=Superimposed Impulse Test.

* If required

Fig. 21 Test sequence for LCC applications [42]

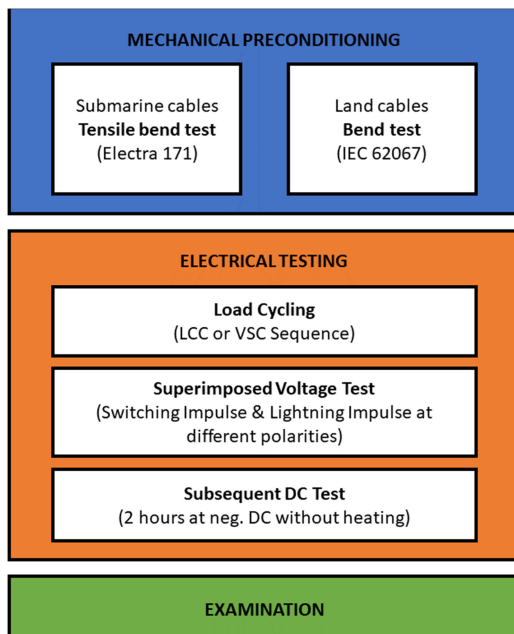

Fig. 22 Schematic overview of steps performed in a type test

converter (LCC) and VSC are proposed. In Fig. 21, the LCC test sequence is shown as an example. In this case, the system has to withstand a polarity change.

The superimposed impulse voltage test has to be passed with ten impulses of positive and negative polarity. It serves as a test to verify the integrity of the cable system. In addition, cable and accessories are visually checked for signs of deterioration with a final examination.

Type tests also have to be performed on a full cable system, though different parts of the system can be tested separately in different test loops including all relevant components. A type tests consists of mechanical preconditioning, load cycle tests and a final examination as shown in the simplified diagram in Fig. 22.

Depending on the application on land or in the sea, the appropriate mechanical preconditioning has to be done according to Electra 171 (submarine applications) or IEC 62067 (land applications), as this will subject the components to mechanical stress that will occur during handling and installation. Concerning the load cycle tests, different sequences for LCC and VSC are proposed. As an example, the sequence for LCC is shown in Table 1 [42].

Subsequently, the cable system has to withstand ten impulses of each proposed switching impulse configuration of the superimposed impulse voltage test. If the cable system will be exposed to lightning strikes a lightning impulse test has to be passed too. The next step in the electrical testing process is the subsequent DC test at negative polarity. As in the prequalification test, all tested components are finally examined for any signs of deterioration.

In addition to electrical tests non-electrical tests specified in IEC 62067 Ed. 2 regarding mechanical properties, ageing

Table 1 Load cycling test sequence for LCC applications

number of cycles	8 × 24 h LC	8 × 24 h LC	8 × 24 h LC	3 × 48 h LC
test voltage	- U_T	+ U_T	PR at U_{TP1}	+ U_T

behaviour, pressure behaviour, water penetration and fire hazards, can be performed as agreed to by customer and supplier. Water integrity tests for submarine applications are specified in Electra 189.

9 Summary

HVDC power transmission is very important for the long-distance transmission, interconnection of asynchronous AC grids and integration of renewable energy in the main power networks. Hence, HVDC cable systems become more and more important. As one of the most important components in an HVDC cable system, the development of terminations requires different design approaches for HVAC cable systems.

Unlike HVAC cable terminations, the electric field distributions are governed by electrical conductivities of insulation materials. Unfortunately, the electrical conductivities of the insulation materials are strongly dependent on the temperature. In this case, the temperature distribution should be evaluated, and the design process should take the electric field distributions under different current loads into account. In this paper, different field grading methods for cable terminations are briefly introduced.

Depending on different applications, the design of cable terminations can vary. However, the stress cone is the most essential part for all types of the termination. The two important aspects for designing the stress cone are following: (i) the shape of deflector; (ii) the insulation material of the stress cone, which should match the cable insulation material regarding the surface charge accumulation. For the latter perspective, an insulation material with an electrical conductivity similar to the cable insulation should be chosen.

The installation of cable terminations is also very important for a reliable operation. Mistakes made during the installation are likely to lead to dielectric breakdown at the weak point. Hence, cable terminations must be installed by qualified personnel and clear, accurate and well-defined installation instructions should be provided.

10 Acknowledgment

This work was supported by the National Key Research and Development Program of China in its project entitle 'Critical Technologies for Designing and Manufacturing ± 500 kV DC Cables and their Accessories' (grant no. 2016YFB0900703).

11 References

- [1] De Clercq, B., Ruiz Prada, C., Papon, M., *et al.*: 'Towards a governance model for the European electricity transmission network in 2050', e-Highway 2050 milestone D5.1, 2015
- [2] U.S. Department of Energy: 'A national offshore wind strategy: creating an offshore wind energy industry in the United States', 2011
- [3] China National Energy Administration: 'Development plan (2014–2016) for national offshore wind power', 2014

- [4] Mazzanti, G., Marzinotto, M.: 'Extruded cables for high-voltage direct-current transmission: advances in research and development', vol. 93 (John Wiley & Sons, Hoboken, NJ, 2013)
- [5] Kim, C.K., Sood, V.K., Jang, G.S., et al.: 'HVDC transmission: power conversion applications in power systems' (John Wiley & Sons, Hoboken, NJ, 2009)
- [6] Worzyk, T.: 'Submarine power cables: design, installation, repair, environmental aspects' (Springer-Verlag, Berlin, 2009)
- [7] Byggeth, M., Johannesson, K., Liljegren, C., et al.: 'The development of an extruded HVDC cable system and its first application in the Gotland HVDC light project'. Proc. Fifth Int. Conf. Insulated Power Cables, JICABLE, Paris-Versailles, France, 1999, pp. 538–542
- [8] Chen, G., Hao, M., Xu, Z., et al.: 'Review of high voltage direct current cables', *Chinese Soc. Electr. Eng. (CSEE) J. Power Energy Syst.*, 2015, **1**, (2), pp. 9–21
- [9] Azizian Fard, M., Reid, A.J., Hepburn, D.M.: 'Influence of HVDC converter operation on partial discharge characteristics'. IEEE Int. Power Modulator and High Voltage Conf. (IPMHVC), San Francisco, 2016, pp. 680–683
- [10] Khalil, M.S., Gastli, A.: 'Dependence of DC insulation resistivity of polyethylene on temperature and electric field'. IEEE 1997 Annual Report Conf. Electrical Insulation and Dielectric Phenomena, Minneapolis, MN, 1997, vol. 1, pp. 296–299
- [11] Boggs, S., Damon, D.H., Hjerrild, J., et al.: 'Effect of insulation properties on field grading of solid dielectric DC cables', *IEEE Trans. Power Deliv.*, 2001, **16**, pp. 456–461
- [12] Jeroense, M.J.P., Morshuis, P.H.F.: 'Electric fields in HVDC paper-insulated cables', *IEEE Trans. Dielectr. Electr. Insul.*, 1998, **5**, (2), pp. 225–236
- [13] Vogelsang, R., Winter, H.-J., Gramespacher, H., et al.: 'Silicone technology for reliable performance of joints and terminations for high voltage polymer power cables'. 8th Int. Conf. Insulated Power Cables, Versailles, France, 2011
- [14] Gramespacher, H., Vogelsang, R., Freilinger, M.: 'Application guide for high voltage accessories' (a publication of the Brugg Cables Academy, Brugg, 2nd edn.), ISBN: 978-3-033-04936-9
- [15] IEC 60815-1: 'Selection and dimensioning of high-voltage insulators intended for use in polluted conditions – part 1: definitions, information and general principles', Edition 1.0, 2008–10
- [16] IEC 60815-4: 'Selection and dimensioning of high-voltage insulators intended for use in polluted conditions – part 4: insulators for d.c. Systems', Edition 1.0, 2016–10
- [17] IEC 62271-209: 'High-voltage switchgear and control gear – part 209: cable connections for gas-insulated metal-enclosed switchgear for rated voltage above 52 kV – fluid-filled and extruded insulation cables – fluid-filled and dry-type cable-terminations', 2007
- [18] EN 50299: 'Oil-immersed cable connection assemblies for transformers and reactors having highest voltage for equipment Um from 72.5 to 550 kV', 2002
- [19] Streit, P., Gallego, K.: 'Dry terminations for high voltage cable systems'. 8th Int. Conf. Insulated Power Cables, Versailles, France, 2011
- [20] Ghorbani, H., Jeroense, M., Olsson, C., et al.: 'HVDC cable systems – highlighting extruded technology', *IEEE Trans. Power Deliv.*, 2014, **29**, (1), pp. 414–421
- [21] Kuchler, A.: 'High voltage engineering' (Springer-Verlag, Berlin, 2017), ISBN 978-3-642-11992-7
- [22] ABB: 'Flexible joint with resistive filed grading material for HVDC cables and method for connecting same to HVDC cables', European Patent Application EP2197080A1, 2008
- [23] Christen, T., Donzel, L., Greuter, F.: 'Nonlinear resistive electric field grading part 1: theory and simulation', *IEEE Electr. Insul. Mag.*, 2010, **26**, (6), pp. 47–59
- [24] Janel, D.: 'Kondensatorgesteuerte Hochspannungsdurchführungen für höchste Gleich- und Wechselspannung'. ETG-Workshop, Feldsteuernde Isoliersysteme, Darmstadt, November 2011
- [25] Virsberg, L., Ware, P.H.: 'A new termination for underground distribution', *IEEE Trans. Power Appar. Syst. (PAS)*, 1967, **86**, pp. 1129–1135
- [26] Strobl, R., Haverkamp, W., Malin, G., et al.: 'Evolution of stress control systems in medium voltage cable accessories'. IEEWES Conf. Proc., Atlanta, 2001
- [27] Roberts, A.: 'Stress grading for HV motor and generator coils', *IEEE Electr. Insul. Mag.*, 1995, **11**, pp. 26–31
- [28] Ye, H., Clemens, M., Schulte-Fischedick, J., et al.: 'Investigation of electrical field grading of bushings with microvaristor filled epoxy resin components'. IEEE Int. Power Modulator and High Voltage Conf. (IPMHVC), Santa Fe, NM, 2014, pp. 153–156
- [29] Jeroense, M., Saltzer, M., Ghorbani, H.: 'Technical challenges linked to HVDC cable development', ABB Review, 2013
- [30] Donzel, L., Greuter, F., Christen, T.: 'Nonlinear resistive electric field grading part 2: materials and applications', *IEEE Electr. Insul. Mag.*, 2011, **27**, (2), pp. 18–29
- [31] Zierhut, S., Klein, T., Wendt, E., et al.: 'Influence of expansion on electric field distribution of stress cones for high voltage cable accessories'. 9th Int. Conf. Insulated Power Cables, Versailles, France, 2015
- [32] Klein, T.: 'Impact of rate of expansion on electric field stress in stress cones & joint bodies'. INMR World Congress, Munich, Germany, 2015
- [33] Wang, P., Wang, J., Li, Z., et al.: 'Nonlinear elastic deformation of cable accessories during expansion and their solutions', *Electric Wire & Cable*, 2016, **2016**, (6), pp. 1–3
- [34] Wagner, K.W.: 'Erklärung der dielektrischen Nachwirkungsvorgänge auf Grund Maxwellscher Vorstellungen', *Archiv für Elektrotechnik*, 1914, **2**, (9), pp. 371–387
- [35] Sillars, R.W.: 'The properties of a dielectric containing semiconducting particles of various shapes', *J. Inst. Electr. Eng.*, 1937, **80**, (484), pp. 378–394
- [36] Quaggia, D.: 'Development of joints & terminations for HVDC extruded cables'. INMR World Conf., Munich, Germany, 2015
- [37] Weissenberg, W., Vogelsang, R.: 'Langzeiterfahrungen mit Hochspannungskabeln und Garnituren'. RCC Fachtagung Werkstoffe, Berlin, Germany, 2009
- [38] Hui, B.: 'Fault Statistics and Typical Case Analysis of High Voltage Cable System', China Society of Electrical Engineering Annual Meeting, 2017. Available at <http://news.csee.org.cn/pic/u/cms/www/201712/zt5-03.pdf>
- [39] Cao, J., Wang, S., Jiang, Y., et al.: 'Fault Analysis of High Voltage Cable Lines in Zhejiang Power Grid', *High Voltage Engineering*, 2016, **42**, Suppl. 2, pp. 577–580
- [40] Galloway, S.J.: 'Cable and accessory installation' (IEE Two Day Colloquium on Super tension, London, 1995), pp. 17/1–17/5
- [41] IEC 62895: 'High voltage direct current (HVDC) power transmission – cables with extruded insulation and their accessories for rated voltages up to 320 kV for land applications – test methods and requirements', 2017
- [42] 'Recommendation for Testing DC Extruded Cable Systems for Power Transmission at a Rated Voltage up to 500 kV', Cigré WG B1.32, 2012
- [43] 'Recommendation for Testing DC Extruded Cable Systems for Power Transmission at a Rated Voltage up to 250 kV', Cigré WG 21-01, 201