

A ballistocardiogram acquisition system for respiration and heart rate monitoring

Original

A ballistocardiogram acquisition system for respiration and heart rate monitoring / Hermann, Sonja; Lombardo, Luca; Campobello, Giuseppe; Burke, Martin; Donato, Nicola. - ELETTRONICO. - 1:(2018), pp. 1-5. (2018 IEEE International Instrumentation and Measurement Technology Conference, I2MTC 2018 Royal Sonesta Hotel, usa 2018) [10.1109/I2MTC.2018.8409750].

Availability:

This version is available at: 11583/2712115 since: 2020-02-17T11:20:18Z

Publisher:

Institute of Electrical and Electronics Engineers Inc.

Published

DOI:10.1109/I2MTC.2018.8409750

Terms of use:

This article is made available under terms and conditions as specified in the corresponding bibliographic description in the repository

Publisher copyright

IEEE postprint/Author's Accepted Manuscript

©2018 IEEE. Personal use of this material is permitted. Permission from IEEE must be obtained for all other uses, in any current or future media, including reprinting/republishing this material for advertising or promotional purposes, creating new collecting works, for resale or lists, or reuse of any copyrighted component of this work in other works.

(Article begins on next page)

© 2018 IEEE. Personal use of this material is permitted. Permission from IEEE must be obtained for all other uses, in any current or future media, including reprinting/republishing this material for advertising or promotional purposes, creating new collective works, for resale or redistribution to servers or lists, or reuse of any copyrighted component of this work in other works.

Title: A ballistocardiogram acquisition system for respiration and heart rate monitoring

Authors:

Sonja Hermann

Dept. of Electronics and Electrical Engineering, School of Engineering, Trinity College, Dublin, Ireland

Luca Lombardo

Dept. of Electronics and Telecommunications, Politecnico di Torino, Torino, Italy

Giuseppe Campobello

Dept. of Engineering, University of Messina, Messina, Italy

Martin Burke

Dept. of Electronics and Electrical Engineering, School of Engineering, Trinity College, Dublin, Ireland

Nicola Donato

Dept. of Engineering, University of Messina, Messina, Italy

DOI: 10.1109/I2MTC.2018.8409750

A ballistocardiogram acquisition system for respiration and heart rate monitoring

Sonja Hermann(member)^a, Luca Lombardo^b, Giuseppe Campobello^c, Martin Burke^a, Nicola Donato (member)^c.

^a Department of Electronic and Electrical Engineering, School of Engineering, Trinity College, Dublin, Ireland.

^b Department of Electronics and Telecommunications, Politecnico di Torino, Italy

^c Department of Engineering, University of Messina, 98166 Messina, Italy

hermanns@tcd.ie, ndonato@unime.it

Abstract— In this paper the development and realization of a compact measurement system for ballisto-cardiogram recording is reported. The system is based on a Linkit ONE, an ARDUINO-like embedded system, and an electronic interface specifically designed as a “Shield” configuration to reduce the dimensions of the entire system. Measurement is electrodeless. Respiration and heartbeat frequency is acquired in the seated position, using a quasi-piezoelectric sensor, made of an electroactive polymer material (EMFIT). The sensing material is in the shape of a small flat oval placed directly on the chair and connected with the measurement system. Preliminary results are reported and discussed.

Keywords—Ballistocardiogram; Embedded System.

I. INTRODUCTION

The ballisto-cardiogram (BCG) is a well-established diagnostic tool used to assess heart health. The BCG record describes a waveform, which provides information on heart forces produced during the cardiac cycle [1]. As such, it offers valuable additional information compared with the sole use of the Electrocardiogram (ECG) in diagnosis. An early mention of the BCG in 1905 describes a BCG measurement device by Yandell Henderson, which consists of a horizontal table, suspended from the ceiling by four wires [2]. The most cited and ground-breaking work was done by Starr. He laid the ground work for the BCG to be used as a diagnostic tool by developing a classification system, which standardizes the interpretation of the BCG record. Starr described the BCG waveform with the letters F, G, H, I, J, K, L, M, and N [3], which reference the movement of blood during the heart cycle [3-8]. He published his findings in a series of papers between 1920 and 1950. Most of the 20th century widespread use of the BCG was hampered by the severe restrictions imposed on the subject during measurement, often breath holding was required. Consequently, the BCG became more and more unpopular in the 1960's and 70's, to the point of its use being almost abandoned entirely. Recent advances in sensors have made it possible to loosen the strict measurement requirements. However, movement of the subject's body and chest during respiration were and still remain major challenges to acquiring a clean BCG record. Current use of the BCG avoids the

aforementioned challenges somewhat, by restricting its usage to acquiring high level information such as heart rate (HR). Respiration and movement, previously considered as artefacts, are now being exploited for diagnostic purposes. The BCG is employed most widely in e-health applications and mobile data collection, where the emphasis is on long-term data collection rather than detail and high accuracy [9-11]. Furthermore, I and I-J amplitude evaluations can help in detecting sub-clinical and early anomalies in large populations, and ultimately in predicting life expectancy. Moreover, clinical monitoring applications can be extended within specific pathologies and their treatment, such as: testing the effects of drugs and other therapies and detecting the presence of coronary artery and aortic valve diseases [12]. The time intervals of the waveforms are sometimes studied as well. These can be measured with reference to the R-spike of the ECG [13].

In order to exploit the BCG to its full diagnostic potential, obtaining information from the BCG waveform beyond its current use, several challenges remain to be solved [14, 15]. The BCG is essentially a vibration signal and as such is susceptible to any vibration disturbance, which may originate from body movement. The signal itself is of small amplitude and needs suitable high-gain amplification. This makes it challenging to provide robust, low noise data acquisition and is seen as the main hindrance to the BCG being used as more than a simple tool in widespread applications. Tasks which are static by nature, and are damaging to the health, for example those involving static or quasi-static sitting, are naturally suitable scenarios that will facilitate the BCG going beyond mainstream applications, as they will not introduce too many motion artefacts. Possible applications are health monitoring of people sitting in electric wheelchairs or manual ones during periods of non-propulsion, static seated tasks such as monitoring situations or seated tasks involving static muscular efforts in manufacturing or its use in medicine during surgery. Assessing the stability of the BCG signal during those tasks and monitoring its change might provide valuable information on the subject's physiological status, in particular heart health or heart and respiration effort. Providing detailed information on how heart and respiration effort are affected by static seated tasks may aid in developing measures for assessing and

predicting task demands, associated fatigue and pressure ulcer risk.

This paper describes a new approach using an embedded system equipped with an ad-hoc electronic interface. It offers flexibility in measurement as both electrode-based ECG heart rate measurement and electrodeless BCG based heart and respiration rate frequency evaluation are incorporated into the system design. It thus offers a dual measurement, which allows for recoding of the ballisto-cardiogram with the possibility of simultaneously recording a 3-lead ECG with electrodes. This provides a compact and mobile system, which also potentially allows for validating the BCG via ECG acquisition. In the current paper we describe the first step in the development of the BCG part of the system, aiming to address some of the BCG challenges described, such as obtaining suitable signal strength and amplification. This represents the first step in the development of a novel recording system, which can be used for risk assessment in static seated tasks. Static sitting in a chair is recorded with an EMFIT thin film sensor. The BCG signal quality for respiration and heart rate frequency and future development steps are discussed.

II. EXPERIMENTS

A. Development of the measurement system

The sensor is a piezoelectric film in which the mobility of charge is proportional to the force applied to the film. This charge generates a minute current which is therefore proportional to the derivative of the force and a resulting voltage which can be detected at the output terminals of the sensor. An electrical equivalent model of the EMFIT sensor used is given in Fig.1.

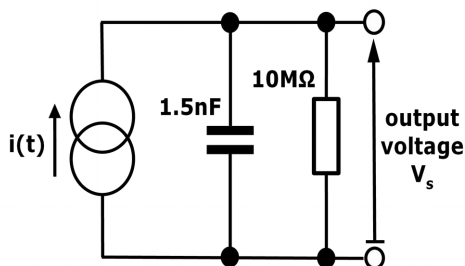

Fig. 1. Electrical Equivalent Model of EMFIT Sensor.

The measurement system is based on two electronic boards. The first one is the open source development board LinkIt One, employed for signal transmission and elaboration. The latter is an electronic interface specifically designed for this application as a shield board. The LinkIt ONE development platform is an open-source, high-performance board for prototyping wearables and IoT devices. It features the System-on-Chip MT2502A having a clock frequency of 260 MHz. Its computing capability is more than sufficient for a high-level data link and medium-level signal processing. The LinkIt ONE can easily save data on micro-SD cards and can exchange data and control

information using the USB, the GSM, the Bluetooth Low Energy and the Wi-Fi. Furthermore, it can be powered by a rechargeable battery and with the integrated GPS it allows geo-tagging. All of these characteristics make it particularly suitable for in-field applications. The shield is a custom designed board for transducing and measuring the ECG signal. It primarily implements the analog front-end for the acquisition of bio-potential signals and their analog-to-digital conversion. The core of the shield is the ADS1292 chip, manufactured by Texas Instruments. This chip implements all of the circuitry needed to acquire bio-potential signals for two fully differential channels. Moreover, it features a low-noise input amplifier with programmable gain, a very flexible input multiplexer, low-power consumption and a precision analog-to-digital converter with a resolution of 24 bits and a sampling rate between 125 and 8000 SPS. The chip is controlled and can exchange data via a dedicated SPI Interface which is connected to the LinkIt ONE. The block diagram of the developed system is shown in Fig. 2. Several decoupling capacitors are included in the circuit in order to improve the noise performance of the chip. For the same purpose, a separate analog ground and supply has been adopted. Sensors or electrodes can be connected to the input connectors, where analog R-C filters having a cut-off frequency of about 66 kHz improve the noise rejection [16, 17]. The input stages of the ADS1292 chip feature high-impedance ($Z_{in}=500M\Omega$), low noise (input-referred noise is 8 μV_{pp}) and good gain ($G_{max}=12$), and this allows minimization of the number of the analog circuits needed for interfacing the EMFIT sensor. The chip also provides a reference output voltage (originally employed as right-leg driver and lead-off detection) that has been used as virtual ground for the sensor. However, this configuration is feasible only for dynamic operation of the EMFIT sensor. A future development of the analog front-end will improve its capabilities.

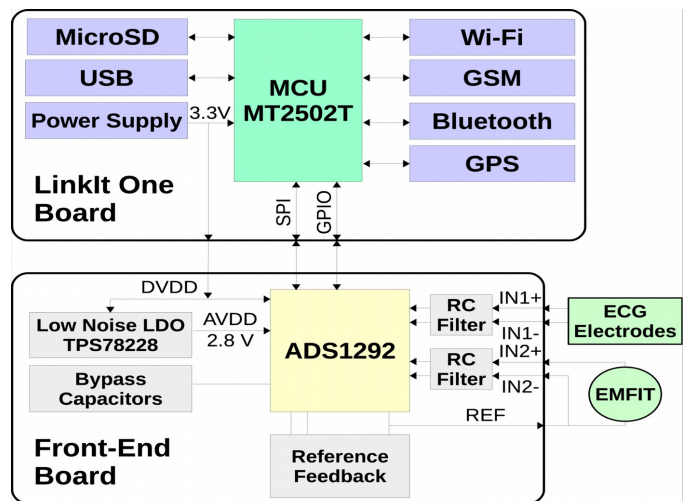

Fig. 2. Block diagram of the system: the EMFIT sensor can be connected to the second channel using the reference electrode as virtual ground.

Finally, the shield includes a dedicated low-noise power supply. The linear regulator TPS78228, (Texas Instruments

Inc.) is used to regulate the analog power supply of the ADS1292, reducing the injection of noise and ripple from the LinkIt ONE into the analog front-end.

The PCB has been developed on two layers using the software KiCad, and the prototyping machine LPKF S103 has been used to manufacture the PCB itself. All components employed are SMD in order to minimize the size of the board. The layouts of the top and bottom layers with the relative component placements are illustrated in Fig. 3.

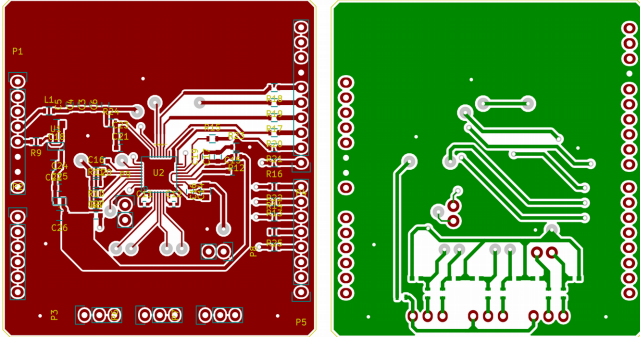

Fig. 3. Layout of the top and bottom layers.

B. Firmware development

The system uses dedicated firmware for the LinkIt ONE microcontroller that has been developed using the Arduino IDE. The principal operations performed by the firmware are the system control and the data acquisition. It operates when connected to a PC with an USB cable or Bluetooth connection. It is able to start and stop a measurement, acquiring data from the ADS1292 using the SPI interface, combine the data from the two channels and convert them into a suitable format. Finally, it is able to send the data to the PC using the selected connection.

C. PC Software development

A PC software graphical user interface (GUI) has been developed using the Python programming language. This software interfaces to the hardware allowing proper control of the system and the visualization in real-time of the data from both channels. An ad-hoc graphics library has been developed to visualize the acquired data and re-scale the graphs automatically. Several threads run concurrently to perform the required operations. The software also allows the exporting of the acquired data to a csv file that can be imported by most data analysis software packages.

III. THE MEASUREMENT PROCEDURE

Some test recordings with the system described above were carried out using a convenient sample of laboratory staff to verify the embedded system's suitability for its purpose as described above. An oval shaped EMFIT sensor (12cm x 3cm) was placed on the left inner quadrant of the seating surface of a

wooden chair, without cushioning. A person was then seated on the chair, making sure that their left bony prominence (ischial tuberosity) was directly placed on the center of the sensor. Correct subject positioning is essential as the signal quality depends on proper body contact with the sensor. Several records of a person seated upright and remaining still for a period of 10 minutes duration were taken. A period of 10 minutes was chosen as it was deemed a suitable length to allow evaluation of the stability of the measurement as learned from previous experience. Data was recorded to test for suitably high signal levels and amplification to provide an adequate BCG trace. Adequate was defined by the signal showing a clearly defined respiration waveform and superimposed peaks corresponding to heart beat.

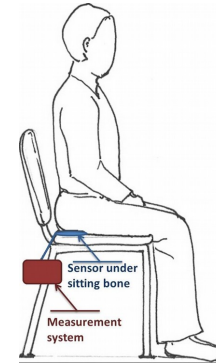

Fig. 4. Measurement system positioning.

IV. RESULTS

With the aim of performing a better evaluation of the recorded data, a FIR (Finite Impulse Response) digital filter was designed and employed. The transfer function and design parameters are presented in Fig. 5 and Table 1, respectively. In order to guarantee their stability and linear phase response, FIR filters are implemented in a non-recursive manner [18]. These specific features are of great importance for biomedical applications given that biomedical signals are primarily concerned with waveform features, e.g. the time at which particular peaks occur. Fig. 6 shows a comparison of the unfiltered and filtered signals in the frequency domain. It confirms that the 50Hz interfering component is completely removed by the FIR filter.

TABLE 1. FIR filter (design parameters).

f_c	20 Hz
Δf	10 Hz
A_s dB	83 dB
A_{cp} dB	3 dB
Coefficients	69
Window	Blackman
f_s	125 Hz

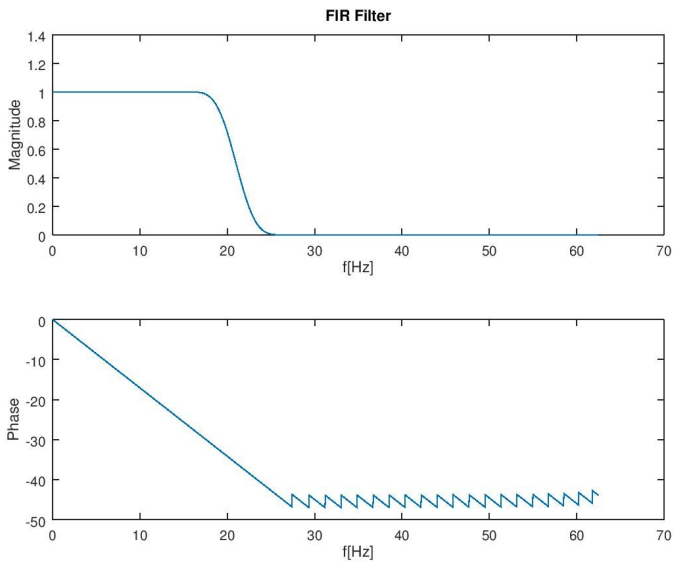

Fig. 5. FIR filter (transfer function).

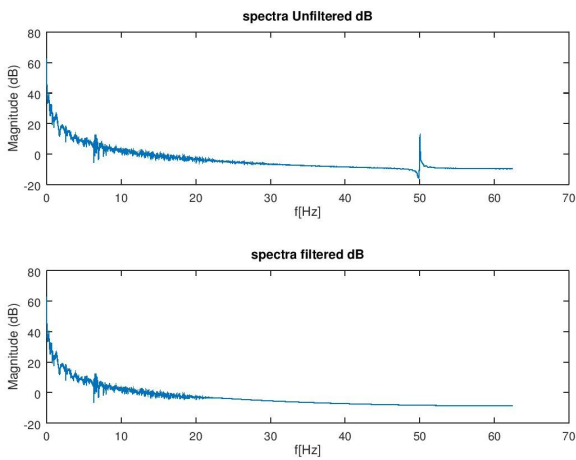

Fig. 6. Comparison of spectra before and after the FIR filter

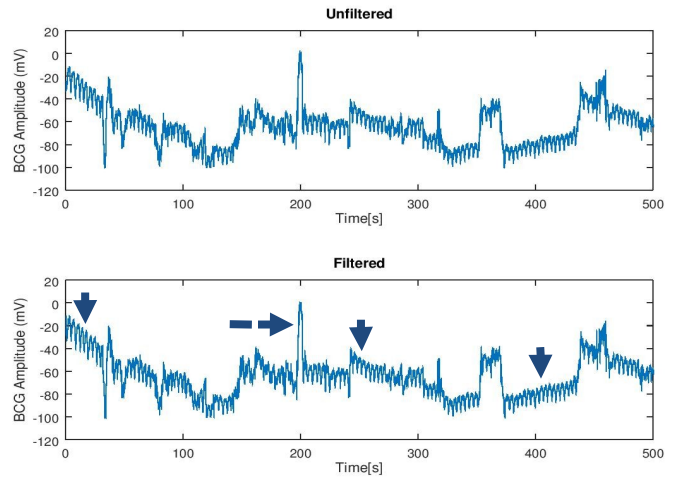

Fig.7. Comparison of filtered and unfiltered signals in the time domain. Arrows indicate examples of respiration peaks, differentiating them clearly from motion artefacts (dashed line arrow).

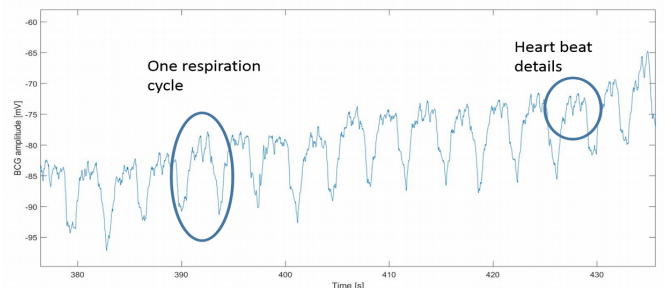

Fig. 8. Enlarged version of the filtered BCG trace in Fig. 7, detailing respiration and heart frequency details.

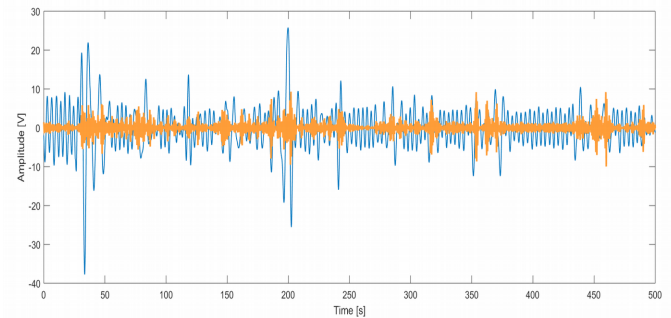

Fig. 9. BCG trace separated into heart rate and respiration waveforms.

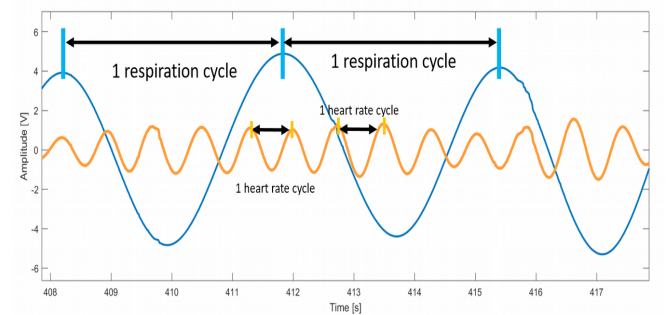

Fig. 10. Enlarged version of the data shown in Fig 9, showing three respiration and associated heart rate cycles.

Fig. 7 shows the same comparison in the time domain. It can be seen that the signal remains undistorted after the FIR filtering operation. The respiration waveform and superimposed heart beat is clearly recognizable in the graph, confirming that the amplification and signal strength of the acquired BCG is adequate to capture heart beat and respiration details. Fig. 8 shows an enlarged version of the signal, detailing respiration and heart cycles in more detail. A BCG trace with separated heart-rate and respiration waveforms is reported in Fig. 9. More precisely, two bandpass filters have been used to extract respiration components (0.1-0.5 Hz) and heart-rate components (1.0 -1.7 Hz), respectively. An enlarged version of the same trace is shown in Fig. 10, detailing three respiration and associated cardiac cycles.

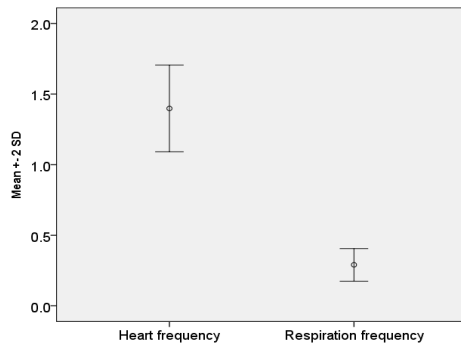

Fig. 11 Mean and standard deviation of heart beat and respiration frequency of the recorded signal shown in Fig. 7.

As shown in Fig. 11, the measured heart rate and respiration frequencies are well aligned with the normal values as defined in [19] and thus demonstrate that the embedded system described by the authors is capable of sufficient accuracy and resolution to capture BCG related signal content.

V. CONCLUSIONS

In this paper the development of a compact system for ballisto-cardiogram recording is reported. It is based on a Linkit ONE embedded system and an ad-hoc designed electronic interface using an ADS1292 integrated circuit. It has been demonstrated that the embedded system approach adopted here is suitable for capturing sufficient details of heart beat and respiration frequency. Therefore, such a system may be deemed suitable for acquiring BCG waveforms. The approach reported has the added advantage of offering parallel ECG recording, while being of a very compact size. The system developed is able to record both heart and respiration rates in both electrodeless (BCG) mode and in electrode mode using the ECG mode. The compactness of the system provides a high level of portability. The unique system design and configuration allows a high degree of flexibility in selecting different data transmission modes, namely Bluetooth, USB and Wi-Fi protocols, thereby offering the flexibility for use in a diverse range of in-field applications.

REFERENCES

- [1] I. Starr, H.A. Schroeder, "Ballistocardiogram. II Normal standards, abnormalities commonly found in disease of the heart and circulation, and their significance," pp. 437-450, 1939.
- [2] H.R.Brown, De Lalla, "Ballistocardiogram, Description and Clinical Use," Amer J. Med., pp. 718-727, 1950.
- [3] I. Starr, A. J. Rawson, H. A. Schroeder and N. R. Joseph, "Studies on the estimations of cardiac output in man, and of abnormalities in cardiac function, from the heart's recoil and the blood's impacts: the ballistocardiogram," Amer. J. Physiol. 127, 1, 1939.
- [4] I. Starr, A. J. Rawson, H. A. Schroeder and N. R. Joseph, "Studies on the estimations of cardiac output in man, and of abnormalities in cardiac function, from the heart's recoil and the blood's impacts: the ballistocardiogram," Amer. J. Physiol. 127, 1, 1939.
- [5] I. Starr. "The ballistocardiograph for clinical research and for routine clinical diagnosis," Harvey Lect. 42, 194, 1947.
- [6] I. Starr. "Essay on the ballistocardiogram," J. Amer. Med. Assoc. 155, 1413, 1954.
- [7] I.Starr. "Über das Ballistokardiogramm," Medizinische, 101, 1955.
- [8] D.C. Deuchar. "Ballistocardiography," British Heart Foundation, Vol. 29:285-288, 1967.
- [9] O. A. Postolache, P. S. Girão, G. Postolache, "Comparative analysis of two systems for unobtrusive heart signal acquisition and characterization," Conf Proc IEEE Eng Med Biol Soc. 2013; pp 7021-7024, 2013.
- [10] Friedrich, X. L. Aubert, H. Fuehr, A. Brauers, "Heart rate estimation on a beat-to-beat basis via ballistocardiography - A hybrid approach," Conf Proc IEEE Eng Med Biol Soc. 2010; pp. 4048-4051, 2010.
- [11] C. Bruesser, S. Winter, S Leonhardt. "Unsupervised heart rate variability estimation from ballistocardiograms," International Journal of Bioelectromagnetism, Vol. 15, No. 1, pp. 1 - 6, 2013.
- [12] Smith N.T., Ballistocardiography in Weissler A.M. (Ed.), Noninvasive cardiology. Grune & Stratton, New York, USA, 1974.
- [13] M. Galeano, A. Calisto, A. Bramanti, S. Serrano, G. Campobello, B. Azzerboni, "R-point detection for noise affected ECG recording through signal segmentation," Conf Proc IEEE Eng Med Biol Soc. 2010; pp. 638-641, 2010.
- [14] Z.Trefny, K.Hana, S.Trojan, V.Toman, S.Herczegh, L.Pousek, J.Slavicek, "New Trends in Balistocardiogrphay," Meas. Sci. Rev., Vol. 3, pp. 45-48, 2003.
- [15] Pinheiro, E.; Postolache, O.; Girão, P. "Theory and developments in an unobtrusive cardiovascular system representation: Ballistocardiography," The Open Biomed. Eng. J. 4, pp. 201-216, 2010.
- [16] <http://www.ti.com/lit/ds/symlink/ads1292.pdf>
- [17] <http://www.ti.com/lit/ug/slau384a/slau384a.pdf>
- [18] E. Ifeachor, B. Jervis, "Digital Signal Processing: A Practical Approach (2nd edition)," Prentice Hall, 2001.
- [19] Malik M., "Heart rate variability-Standards of measurement, physiological interpretation and clinical use, Task Force European Society of Cardiology and The North American Society of Pacing and Electrophysiology," Eur. Heart J. 17, pp. 354-81, 1996.