

SaPPART Guidelines: Assessment of positioning performance in ITS applications

Original

SaPPART Guidelines: Assessment of positioning performance in ITS applications / Becker, Uwe; Bétaille, David; Cristodaro, Calogero; Dosis, Fabio; Engdahl, Jesper; Gilliéron, Pierre-Yves; Leppäkoski, Helena; Codrut Nemtanu, Florin; Niculescu, Mihai; Ortiz, Miguel; Ochieng, Washington; Peyret, François; Renaudin, Valérie; Ruotsalainen, Laura; Spyropoulou, Ioanna. - ELETTRONICO. - (2018).

Availability:

This version is available at: 11583/2710520 since: 2018-07-05T12:44:01Z

Publisher:

Published

DOI:

Terms of use:

This article is made available under terms and conditions as specified in the corresponding bibliographic description in the repository

Publisher copyright

(Article begins on next page)

TECHNIQUES ET MÉTHODES

SaPPART Guidelines

Performance assessment of positioning terminals

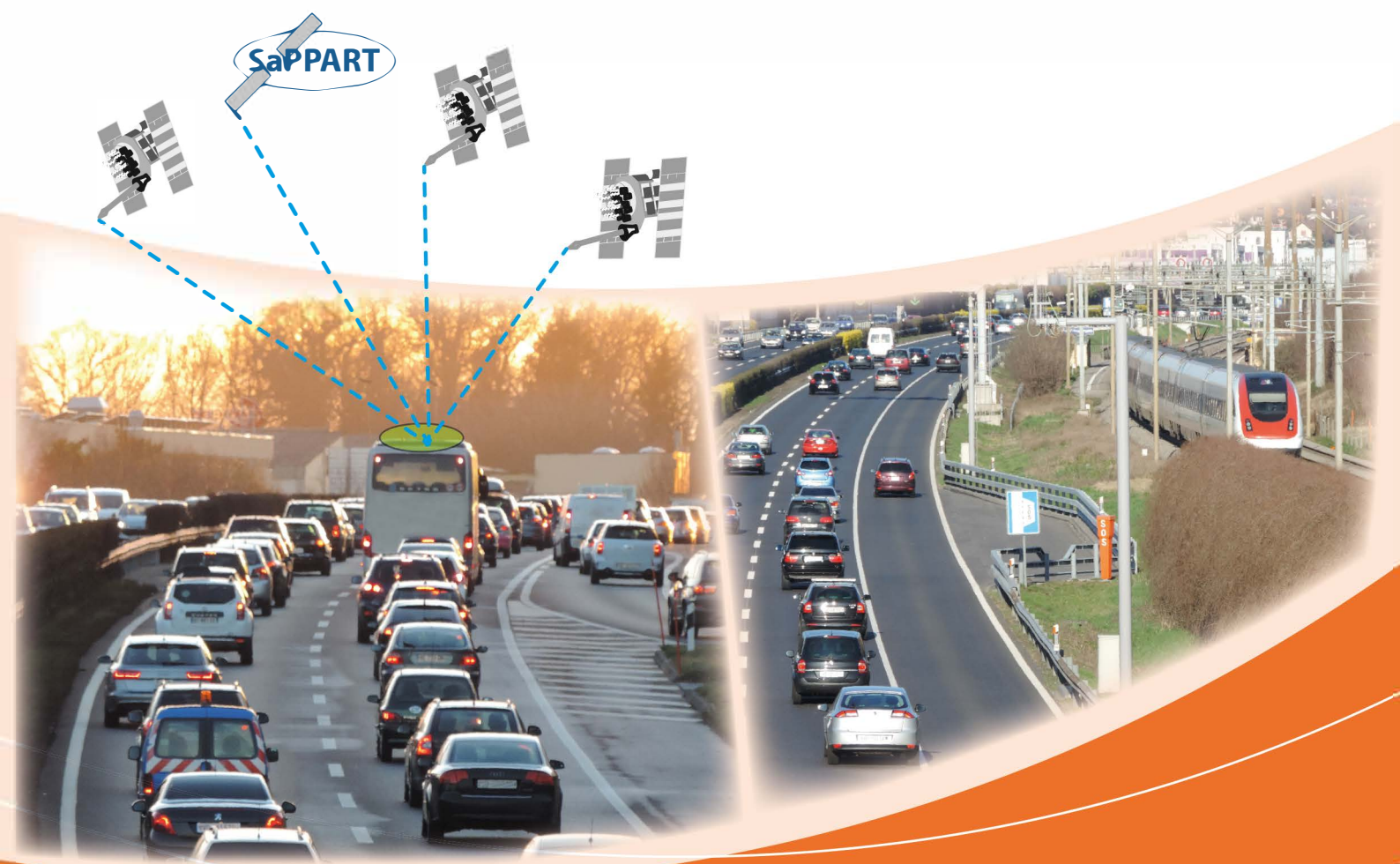

Satellite Positioning Performance Assessment for Road Transport
COST Action TU1302

TMI 3



SaPPART Guidelines

Performance assessment of positioning terminals

March 2018



TECHNIQUES ET MÉTHODES

These guidelines are the third deliverable of SaPPART COST Action. The first deliverable is the white paper and the second one is the handbook.

It was written under the direction of François Peyret and Pierre-Yves Gilliéron, respectively chair and vice-chair of the Action.

The contributors are (by alphabetical order):

Uwe Becker, Technische Universität Braunschweig, Germany

David Bétaille, Institut français des sciences et technologie des transports, de l'aménagement et des réseaux (Ifsttar), France

Calogero Cristodaro, Politecnico di Torino, Italy

Fabio DAVIS, Politecnico di Torino, Italy

Jesper Engdahl, Rapp Trans SA, Switzerland

Pierre-Yves Gilliéron, École polytechnique fédérale de Lausanne (EPFL), Switzerland

Helena Leppäkoski, Tampere University of Technology, Finland

Florin Codrut Nemtanu, Politehnica University of Bucharest, Romania

Mihai Niculescu, Intelligent Transport Systems Romania, Romania

Miguel Ortiz, Institut français des sciences et technologie des transports, de l'aménagement et des réseaux (Ifsttar), France

Washington Ochieng, Imperial College, United Kingdom

François Peyret, Institut français des sciences et technologie des transports, de l'aménagement et des réseaux (Ifsttar), France

Valérie Renaudin, Institut français des sciences et technologie des transports, de l'aménagement et des réseaux (Ifsttar), France

Laura Ruotsalainen, Finnish Geospatial Research Institute, National Land Survey (FGI NLS), Finland

Ioanna Spyropoulou, National Technical University of Athens, Greece

This article/publication is based upon work from COST Action SaPPART, supported by COST (European Cooperation in Science and Technology).

COST (European Cooperation in Science and Technology) is a funding agency for research and innovation networks.

Our Actions help connect research initiatives across Europe and enable scientists to grow their ideas by sharing them with their peers. This boosts their research, career and innovation.

www.cost.eu

Please refer to this work as follows:

COST Action TU1302. SaPPART Guidelines: Assessment of positioning performance in ITS applications. Ifsttar, 2018. techniques et méthodes, TMI 3. 45p. ISBN 978-2-85782-741-2



This work is licensed under a Creative Commons Attribution-NonCommercial-NoDerivatives 4.0 International License. To view a copy of this license, visit <http://creativecommons.org/licenses/by-nc-nd/4.0/>

French Institute of Science and Technology for Transport, Development and Networks - Ifsttar
14-20 boulevard Newton - Cité Descartes - Champs-sur-Marne - 77447 Marne-la-Vallée cedex 2
www.ifsttar.fr

Les collections de l'Ifsttar – techniques et méthodes – TMI 3

ISBN 978-2-85782-741-2– ISSN: 2492-5438

Table of contents

Executive summary	7
Introduction	9
Objective	9
Content	9

Chapter 1.

Performance metrics and classes for a positioning terminal

1.1 Performance metrics adopted in SaPPART	13
1.1.1 Availability metrics	13
1.1.2 Accuracy metrics	13
1.1.3 Integrity metrics	14
1.2 Performance classes (example of horizontal position).....	14
1.2.1 Performance classes for horizontal position availability.....	14
1.2.2 Performance classes for horizontal position accuracy	15
1.2.3 Performance classes for horizontal position integrity.....	16

Chapter 2.

Test procedures for GBPT performance assessment

2.1 The fundamental trade-off for the GBPT performance assessment tests.....	21
2.2 Field tests	24
2.2.1 Definition and required equipment	24
2.2.2 Advantages and drawbacks	24
2.2.3 Existing facilities in Europe.....	24
2.3 Lab tests	25
2.3.1 Definition and required equipment	25
2.3.2 Strengths and weaknesses	25
2.3.3 Existing equipment and facilities in Europe.....	26
2.4 R&R tests	26
2.4.1 Definition and required equipment	26
2.4.2 Strengths and weaknesses	26
2.4.3 Existing equipment	27
2.5 Synthesis	27

Conclusion on performance assessment	29
References	31
Appendix A: R&R tests based on Software Defined Radio	33
Technical considerations	33
Testing a GBPT receiver: a real example	34
Equipment used.....	34
Horizontal position error performance assessment.....	35
Appendix B: Some examples of specific functions for R&R tests on hybridized terminals	37
List of acronyms	39
List of figures	41
List of tables	43

Executive summary

With the continuing significant rise in the number of mission critical services and applications in road transport that make extensive use of positioning information, the necessity of a certification framework for positioning performance assessment has become obvious for the majority of stakeholders. The objective of this certification framework is to make clear for the stakeholders the level of performance that the various positioning terminals on the market are capable of, in actual operating conditions.

In addition to an agreed framework, certification requires reference documents such as standards, and technical specifications or reports, developed by standardization bodies. The standards needed for performance verification of a positioning terminal should answer at least the two main questions: “What performance metrics should be used?” and “What tests should be performed?”

Among the performance metrics, the most important for the end user should be able to quantify: the availability of the position, velocity and time (PVT) information, its accuracy (How far am I from the truth?) and its integrity (How can I be sure that I will never be too far from the truth?). Based upon the numerical results for these three main metrics, the next step towards facilitating the certification processes is to define performance classes. In particular for horizontal position accuracy, which is generally of high interest for the user, this document proposes two different classification approaches, one based upon the technology and the other, the applications requirements.

Considering the test procedure, since the positioning terminals providing PVT information to the client application are generally based on Global Navigation Satellite Systems (GNSS), their outputs are highly sensitive to the conditions of use. Therefore, the testing mechanisms should be capable of creating, simulating or reproducing these conditions of use.

Three different approaches exist, with their respective advantages and drawbacks: field tests with the terminal to be tested being on-board of a specific test vehicle, laboratory tests, using synthetic signals produced by constellation simulators and the “record and replay” (R&R) tests which comprise a combination of the two aforementioned approaches. This latter approach provides a good compromise between cost-effectiveness, repeatability and realism that is expected for professional tests.

Introduction

This document is the third deliverable of the COST Action SaPPART, a European network of scientists and stakeholders that aims to promote smart use of GNSS technology in the field of intelligent road transport and mobility. The two first deliverables are the *White Paper* [1] and *Handbook* [2].

It discusses the performance assessment of the GNSS-based Positioning terminals (GBPT), which is generally under the responsibility of the system integrators in the road market of GNSS. In addition, the document serves as a good reference for those involved in the positioning and transport domains.

Objective

The objective of this document is to provide guidelines for generic test procedures for the evaluation of GBPT performance, either by field tests, simulations or their combination, in line with the concepts and definitions already established in the SaPPART *White Paper* and *Handbook*. The document is intended to provide the reader with a helpful tool for planning the GBPT testing procedures by discussing testing in general and providing some detailed practical information.

Content

This document, *SaPPART Guidelines – Performance assessment of positioning terminals*, is structured as follows.

Chapter 1 is the executive summary. Chapter 2 introduces the substantive document including its objective and content.

Chapter 3 recalls the performance metrics proposed by the standardization group on “Navigation and positioning receivers for road applications” (CEN-CENELEC TC5 WG1), adopted in SaPPART. The performance classes for accuracy, availability and integrity discussed in the *Handbook* are revisited and presented using horizontal positioning as an example.

Chapter 4 focuses on the three different testing approaches: field, laboratory, and record & replay testing. The requirements set for the equipment and procedures for all three are defined as well as the strengths and weaknesses. The chapter concludes with a table summarizing the strengths and weaknesses for each approach, potentially useful information for planning the GBPT testing.

Chapter 5 concludes on the performance assessment procedures presented in this document.

Appendix A provides an insight into the R&R approach through the presentation of an implemented scenario. It shows the system architecture for R&R testing and gives detailed information on system setup via the description of a test case.

Appendix B provides some references on specific functions of GNSS constellation generators for hybridized terminals.



Chapter 1.
Performance metrics and classes
for a positioning terminal

1.1 Performance metrics adopted in SaPPART

The definition of the performance metrics relies on the definitions proposed by CEN-CENELEC TC5 WG1 and supported by SaPPART. They are introduced and discussed in detail in the *Handbook* [2].

CEN-CENELEC TC5 WG1 considers, in its suite of standards EN 16803 [3], that the different performance metrics characterizing the global performance of a GNSS-based positioning terminal (GBPT) can be split into two groups:

- “basic” metrics, composed of **availability**, **accuracy** and **integrity**, already described in EN 1608-1 and in the SaPPART *Handbook*, which will be complemented by the metric **continuity** in the second release of the standard,
- “timing” metrics comprising time-to-first-fix (TTFF) but also output latency, output rate and resolution of position, velocity and protection level.

Since CEN-CENELEC TC5 WG1 and SaPPART focus on ITS domain, no specific metric for measuring the accuracy of the GNSS time (T component of the PVT) has been proposed, this accuracy being generally more than sufficient for the ITS applications.

Regarding security issues, the robustness of the GBPT, when subjected to an attack such as jamming, meaconing or spoofing, can be evaluated by the degradation of performance using the same metrics, although the measurement of the detection and mitigation capacities of the GBPT could be interesting also, when adequate flags or indicators are available in the outputs of the terminals.

This document addresses only the basic metrics of availability, accuracy and integrity. These metrics can be applied to many different PVT components (i.e. horizontal / vertical position, horizontal / vertical velocity, etc.). In this, we consider only the **horizontal position** as an example, as it represents the most widely used positioning quantity for the majority of ITS applications.

1.1.1 Availability metrics

The distribution over time of the epochs of (un)availability is of greater interest for an application than the global percentage of time in which a valid position output is available or not.

For this reason, SaPPART adopted the following metric for position availability, proposed by CEN-CENELEC TC5 WG1, which depends on the time period Δ :

Horizontal position availability metric:

Percentage of time intervals of length Δ during which the positioning terminal provides at least one valid horizontal position output.

1.1.2 Accuracy metrics

Horizontal position accuracy metric:

Set of three statistical values given by the 50th, 75th and 95th percentiles of the cumulative distribution function (CDF) of horizontal position errors (HPE).

1.1.3 Integrity metrics

Integrity is typically expressed by two quantities; the protection level (PL) and its associated integrity risk (IR). Consequently, integrity metrics make sense only when the output of the positioning terminal includes a quantity (PL) bounding the error in real-time with a given probability (IR).

The metrics adopted by SaPPART characterize the performances of protection levels in two different ways. Firstly, they refer to the statistical behaviour of the protection levels themselves, i.e. their size in a statistical sense, which is directly linked to their usability for a specific application. Secondly, they describe their reliability as error bounds, which refers directly to the integrity risk itself.

Naturally, since this protection level may not be available at the output of the terminal, these two metrics need to be complemented with a protection level availability metric, similar to the position availability metric.

The definitions of the 3 integrity metrics are:

Horizontal position protection level availability metric:

Percentage of time intervals of length Δ during which the positioning terminal provides at least one valid horizontal position output with the associated protection level.

Horizontal position protection level performance metric:

Set of three statistical values given by the 50th, 75th and 95th percentiles of the cumulative distribution of horizontal position protection levels computed for a certain target integrity risk (e.g. equal to 10^{-5}).

Horizontal position integrity risk metric:

Probability that the horizontal position error exceeds the horizontal position protection level.

1.2 Performance classes (example of horizontal position)

In SaPPART, following the proposals from CEN-CENELEC TC5 WG1, we adopted the simple and practical approach consisting of the definition of three performance classes for each feature.

These three classes are defined by determining two boundaries for the metrics, which are unique and independent of the environmental conditions.

1.2.1 Performance classes for horizontal position availability

Once the parameter Δ is fixed (for instance 10 s), three PVT availability classes can be defined as follows:

Table 1
Availability classes

Availability classes	A = Availability (Δ)
Class 1	$A > 99\%$
Class 2	$95\% < A \leq 99\%$
Class 3	$A \leq 95\%$

According to the requirements of the client application, a different Δ value can be preferred with values other than 99% and 95% for the boundaries.

1.2.2 Performance classes for horizontal position accuracy

In the *Handbook* [2], a tentative classification in three classes based upon the different performance levels generally achieved by the main GNSS technologies was proposed.

- Class 1 for the very accurate dual frequency and phase-differential receivers operating in relatively clear open-sky environments.
- Class 2 for the majority of standard mono-frequency (mono or bi-constellation) stand-alone mass-market receivers operating in relatively clear environments with an external roof-top antenna.
- Class 3 for the same types of receiver as Class 2, but operating in constrained environments, like deep urban environments or with integrated antenna inside a vehicle.

These classes are recalled in Table 2 below and illustrated in Figure 1 for horizontal positioning (HPE, CDF).

Table 2

Performance classes based on technologies for horizontal position accuracy

Horizontal accuracy classes	P = 50 th percentile	P = 75 th percentile	P = 95 th percentile
Class 1	$P \leq 0.2$ m	$P \leq 0.3$ m	$P \leq 0.5$ m
Class 2	0.2 m < $P \leq 2.0$ m	0.3 m < $P \leq 3.0$ m	0.5 m < $P \leq 5.0$ m
Class 3	$P > 2.0$ m	$P > 3.0$ m	$P > 5.0$ m

Figure 1

Performance classes based on technologies for horizontal position accuracy

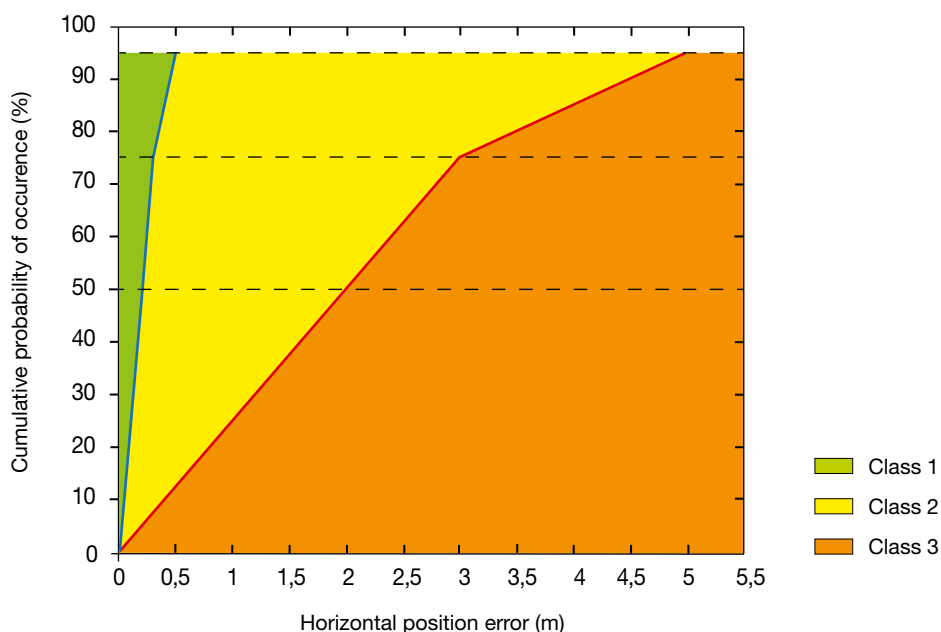

To be classified in class X, the horizontal positioning errors corresponding to the three percentiles (represented by the three horizontal dashed lines) must be located in the corresponding area or in the one above. If one of them is located in the area below, the GBPT is classified in the class below.

Another approach is to propose classes consistent with some main groups of applications.

These main groups are:

- The very demanding applications such as autonomous driving that require a decimetre or “in-lane” accuracy,
- The group requiring lane-level accuracy, like lane-level navigation or road user charging on express lanes,
- The group requiring carriageway-level accuracy, e.g. fleet management or usage-based insurance,
- The group requiring area-level (modest) accuracy such as the smart tachograph.

This approach leads to five classes (Table 2) including applications that require performance lower than the area-level class.

Table 3
Performance classes based on applications for horizontal position accuracy

Horizontal accuracy classes	P = 50 th percentile	P = 75 th percentile	P = 95 th percentile
Class 1 “in-lane”	$P \leq 0.1 \text{ m}$	$P \leq 0.15 \text{ m}$	$P \leq 0.25 \text{ m}$
Class 2 “lane”	$0.1 \text{ m} < P \leq 0.4 \text{ m}$	$0.15 \text{ m} < P \leq 0.6 \text{ m}$	$0.25 \text{ m} < P \leq 1.0 \text{ m}$
Class 3 “carriageway”	$0.4 \text{ m} < P \leq 4.0 \text{ m}$	$0.6 \text{ m} < P \leq 6.0 \text{ m}$	$1.0 \text{ m} < P \leq 10 \text{ m}$
Class 4 “area”	$4.0 \text{ m} < P \leq 40 \text{ m}$	$6.0 \text{ m} < P \leq 60 \text{ m}$	$10 \text{ m} < P \leq 100 \text{ m}$
Class 5 “no specific” or “coarse”	$P > 40 \text{ m}$	$P > 60 \text{ m}$	$P > 100 \text{ m}$

1.2.3 Performance classes for horizontal position integrity

The integrity of a GBPT is a three-fold feature. Firstly, a protection level corresponding to the PVT component to protect (horizontal position in in this case) needs to be available. Secondly, this protection level needs to be practically usable, i.e. as small as possible. Finally, the corresponding integrity risk needs to be respected. Therefore, the classification in terms of integrity will be three-fold and can be expressed by the three classes corresponding to the following tables.

Table 4
Performance classes for protection level availability

PL availability classes	A = Availability (Δ)
Class 1	$A > 99\%$
Class 2	$95\% < A \leq 99\%$
Class 3	$A \leq 95\%$

Table 5

Performance classes for horizontal protection level size (consistent with the technologies-oriented classification of horizontal accuracy of Table 2)

PL Size Classes	P = 50 th percentile	P = 75 th percentile	P = 95 th percentile
Class 1	$P \leq 1 \text{ m}$	$P \leq 1.5 \text{ m}$	$P \leq 2.5 \text{ m}$
Class 2	$1 \text{ m} < P \leq 10 \text{ m}$	$1.5 \text{ m} < P \leq 15 \text{ m}$	$2.5 \text{ m} < P \leq 25 \text{ m}$
Class 3	$P > 10 \text{ m}$	$P > 15 \text{ m}$	$P > 25 \text{ m}$

Table 6

Performance classes for integrity risk

IR Classes	Integrity Risk
Class 1	$IR \leq 1E-6$
Class 2	$1E-6 < IR \leq 1E-4$
Class 3	$IR > 1E-4$

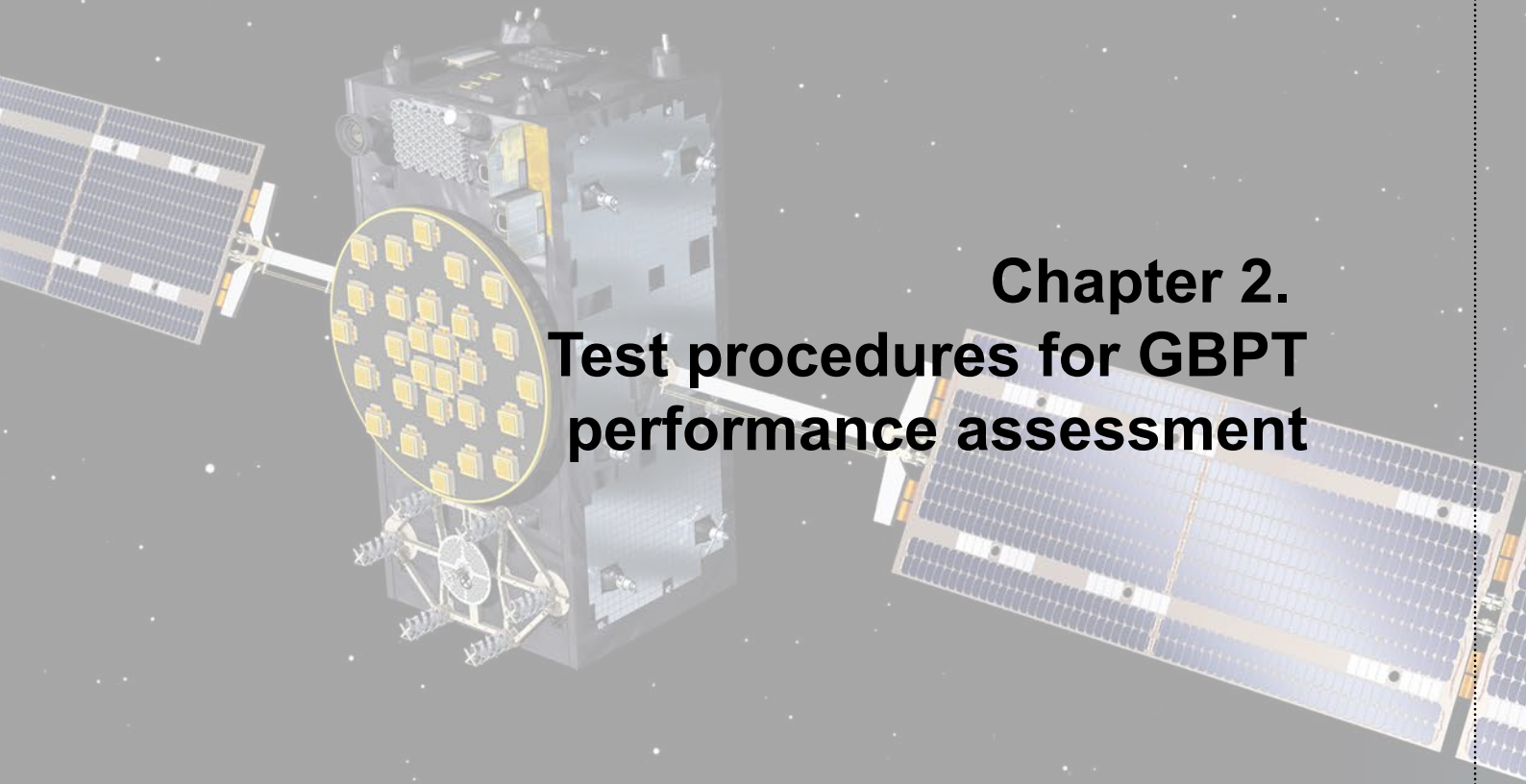

**Chapter 2.
Test procedures for GBPT
performance assessment**

In the ITS domain, different stakeholders are involved at the different levels in the value chain, from the chipset manufacturer to the final user. Figure 2 below, from the European GNSS Agency (GSA), shows the main stakeholder categories in this value chain including the main players.

The GBPT is generally produced by the so called “Tier 1 suppliers” who are also responsible for performance assessment. At the other levels of the chain, other stakeholder categories are responsible for the positioning performance assessment of the system they are producing or integrating. The receiver manufacturer carries out tests without much consideration of the relevant applications, preferably in a laboratory. The vehicle manufacturer is mainly interested in the behaviour of the positioning device on-board of a vehicle, in the context of the other telematics systems and under operational conditions. Finally, the end-user is interested in the performance assessment of the whole ITS system, together with the application module (scope of the *SApPART Handbook*).

The *Guidelines* presented here involve only the performance assessment of the GBPT, under the responsibility of the system integrator who can be a Tier 1 supplier, and possibly a vehicle manufacturer.

Figure 2
The value chain in the road market of GNSS (GSA market study)

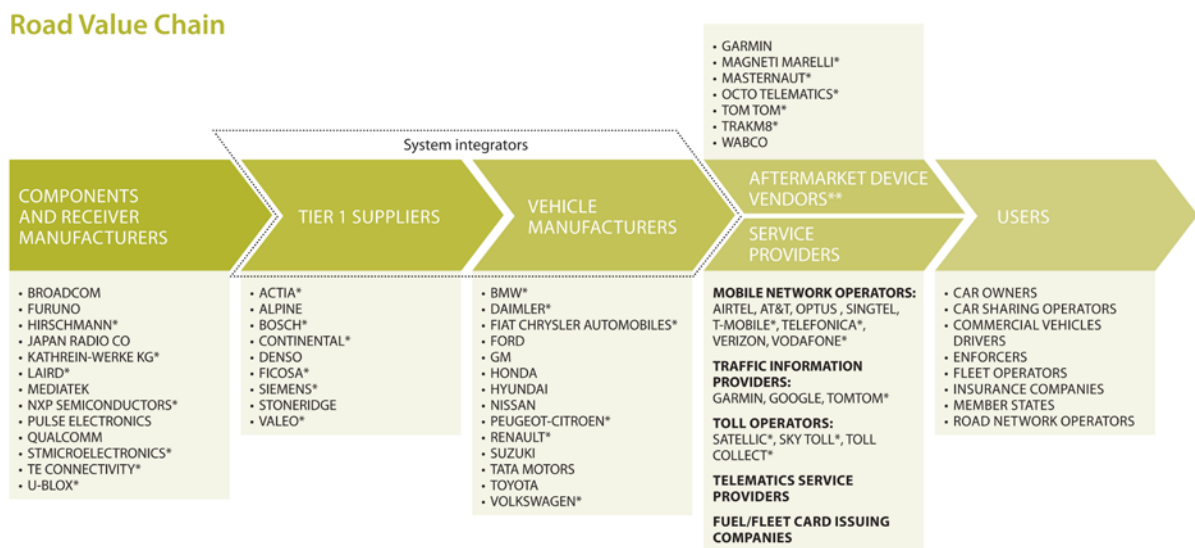

2.1 The fundamental trade-off for the GBPT performance assessment tests

Three main approaches are generally proposed: field tests, lab tests and R&R tests.

Field tests use specific test vehicles that embed a reference trajectory measurement system (RTMeS) for delivering the ground truth, and the GBPT under test on-board of a vehicle. Figure 3 illustrates this approach with the RTMeS from Ifsttar.

Lab tests use a GNSS signal simulator to transmit the signals to the GBPT under test either directly through a cable (when the receiver can be accessed behind its antenna) or through radio waves inside an anechoic chamber when the antenna is embedded in the receiver module.

Figure 3
Dedicated test vehicle equipped with a Reference Trajectory Measurement System

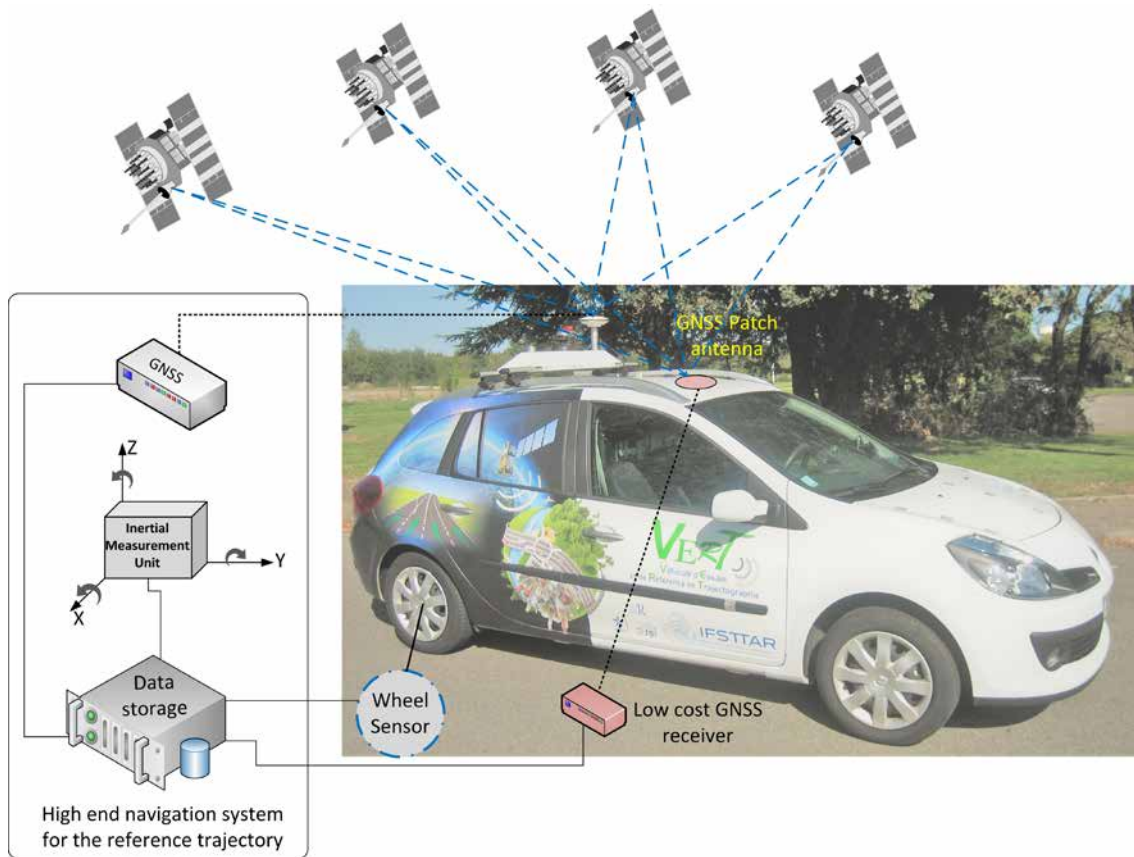

Source: Ifsttar, Nantes

Figure 4
Laboratory setup including the simulator on left connected via a cable to a GNSS receiver and a radio front-end

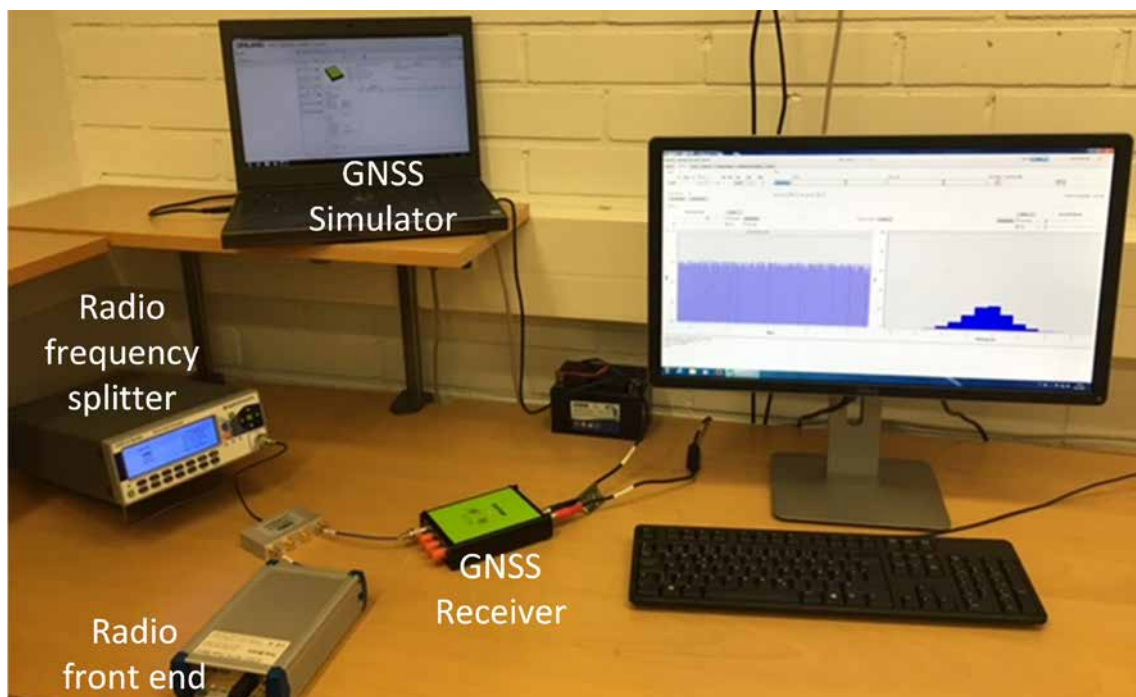

Source: Finnish Geospatial Research Institute, Giorgia Ferrara

Record & replay tests are a type of combined solution between the two aforementioned tests, consisting in recording real sensor data (from a GNSS receiver and other sensors for hybridized positioning) and replaying them in the lab to evaluate the performances of the GBPT under test.

Figure 5
GNSS Principle of R&R tests on GBPT

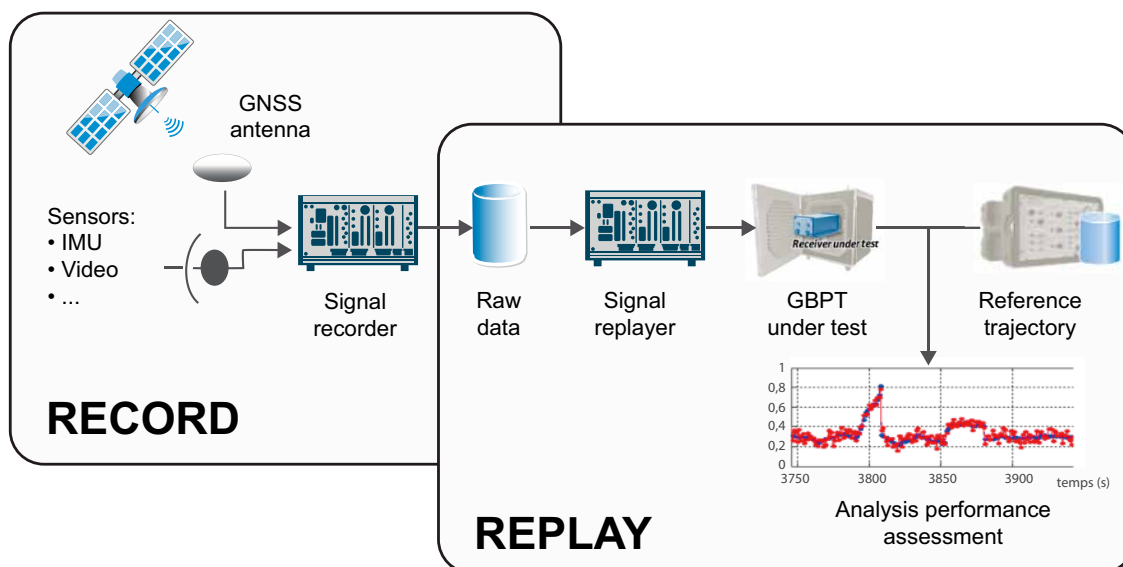

All the test protocols, regardless of the approach, follow largely the same logic:

1. Definition of the scenario:
 - a. Installation conditions of the terminal on-board the vehicle (GNSS antenna on the roof, behind the wind shield, location of the other sensors if any...)
 - b. Trajectories (in terms of position and speed)
 - c. Environmental conditions (relative geometry of the satellites, obstacles, RF environment, weather conditions, ionosphere conditions, etc.)
 - d. Choice of the metrics to be applied
2. Installation of the GBPT (real or virtual)
3. Execution of the tests
4. Recording of the outputs of interest from the GBPT, together with the reference trajectory (perfectly known in a simulator for lab tests, obtained with a RTMeS for field tests or R&R tests)
5. Computation of the errors (generally in terms of horizontal position, but could be also in terms of 3D position, or vertical position, or any velocity component, depending of the PVT component of interest)
6. Application of the metrics and determination of the performance classes

The three approaches offer advantages and drawbacks that are summarized at the end of the chapter.

2.2 Field tests

2.2.1 Definition and required equipment

Field tests follow a methodology where the test scenarios are designed to be representative of the real conditions in which the positioning device will operate.

These conditions should be defined a priori. A list of use cases, with specified environmental conditions, should be defined and appropriately characterized, using e.g. the six different environments which are defined in EN16803-1. The main idea of field tests is to try to place the equipment under test in a variety of such conditions qualitatively, within a range of characteristics which are predefined quantitatively and may impact on its behaviour.

In addition, the estimated performance class of the equipment under test should be accurate and reliable. This is achieved by using, simultaneously with the equipment under test, an RTMeS with performance level of at least one order of magnitude better than that of the equipment under test. For example, if lane level positioning is targeted, the reference trajectory should be accurate at the decimetre level.

2.2.2 Advantages and drawbacks

Pure field tests are the most representative of the real conditions and relatively easy to carry out, but suffer from drawbacks in terms of repeatability, comparability of different test runs and cost effectiveness. Each new assessment on a new GBPT requires new test runs of the vehicle. Even with the best care for reproducing the same trajectory and conditions, differences in the final results between two different GBPTs could arise not only from the differences in the quality of the terminals but also the field test conditions.

Another weakness of field tests is the impossibility to assess very low integrity risks (e.g. 10^{-6}) due to the size of the sample that should remain relatively small for obvious cost reasons.

2.2.3 Existing facilities in Europe

The term “facilities” here means vehicles equipped for equipment installation, data recording and ground truth provision. Considering GBPTs for ITS applications, as most target in-lane accuracy, hybridized inertial navigation systems (INS) coupling GNSS and navigation-grade inertial measurement unit (IMU) constitute a reasonable ground truth.

One example of such vehicles is the VERT (Véhicule d'Essais et de Référence en Trajectographie) vehicle from Ifsttar. References [4] and [5] describe the equipment itself and how the methodology and reference equipment (dual-frequency post-processed GNSS coupled with a high-grade IMU equipped with fibre-optics gyroscopes) was validated. The main idea for validating the INS was to apply random artificial GNSS satellite masks so that GNSS coupling with the IMU data became impossible for a while, typically one minute, and examine how much the computed trajectory in such a case deviates from the original one, computed with no mask. The growth in the INS error under degraded GNSS visibility gives provides an understanding of the performance of the reference equipment.

Other vehicles similar to the VERT vehicle are used by laboratories or private companies in Europe, e.g. (non-exhaustive list):

- GUIDE laboratory (France),
- Renault (France),
- GMV (Spain),
- Imperial College London, etc.

2.3 Lab tests

2.3.1 Definition and required equipment

Laboratory tests, by means of GNSS signal simulators, are used to generate test signals for different defined scenarios. These instruments enable the simulation of the GNSS errors in a controlled and repeatable way by using pre-defined trajectories and mathematical models to determine the appropriate signal at the output. Laboratory testing is performed in a dedicated suitable area, usually an anechoic chamber or via a cable which connects directly the simulator to the receiver, behind the GNSS antenna. The equipment required should at least consist of a signal simulator, cable and the GNSS receiver.

2.3.2 Strengths and weaknesses

Laboratory testing allows the user to define different scenarios where different GNSS systems, transmitted signals and environmental effects may be selected. The strength of the approach over field testing is that the tests are repeatable as many times as desired under exactly the same known conditions. The scenarios may be defined to include, for example, a certain amount of multipath, signal obstructions or interference. Lab tests are time and cost efficient and offer the possibility to test the receiver in virtual locations; the user may for example simulate the signal environment at the other side of the world or in dangerous locations. The scenarios may also be dynamic. On the contrary to field tests, very long tests necessary for assessing low integrity risks are easier to implement.

One weakness of laboratory testing is the need for expensive dedicated GNSS signal simulators, as well as dedicated premises or cabling for testing. Fortunately, there are some existing facilities in Europe which may be used for testing purposes (see 2.3.3). Other drawbacks are that some technological knowledge of GNSS for defining the scenarios is needed and the hybridization of GNSS and other positioning means may be simulated only up to a certain level. Some simulators provide models for fusion of inertial sensor measurements and GNSS (see Appendix B), but other sensors and means for positioning are rarely implemented.

The main weakness of laboratory testing, as far as performance in difficult environments is concerned, is that pure simulators have difficulties to simulate the real, physical phenomena that are usually experienced by a GBPT operating in the real conditions. For instance, the performance of an on-board unit located behind a windshield of a vehicle driving on a tree-lined boulevard in a city cannot be faithfully simulated only with software.

2.3.3 Existing equipment and facilities in Europe

Many manufacturers have developed GNSS constellation simulators in Europe, including SPIRENT, Rohde and Swartz, LabSat, and M3 Systems (with National Instruments).

The European Space Agency (ESA) operates two testing facilities in Europe accessible for laboratory testing, at the “European Space Research and Technology Centre” (ESTEC) located in Noordwijk, Netherlands, and the “GNSS Innovation Demonstration and Test Centre” in Paignton, UK.

The European Commission’s “Joint Research Centre” (JRC) in Ispra, Italy, is also capable of executing various types of tests on GNSS receivers, including simulations.

2.4 R&R tests

2.4.1 Definition and required equipment

The R&R approach might be considered as the combination of the laboratory and field tests. Therefore, it represents an innovative technique for the assessment of the GNSS receiver performance. It consists of two main processes: *recording* and *replaying*. Real data from GNSS and other sensors for hybridized positioning are recorded and then replayed in the laboratory. The reconstructed signal is then fed into the receiver under test. Finally, performance is assessed with respect to the reference provided by the RTMeS.

At the recording stage the required equipment are the data-grabber (recorder), the RTMeS and, eventually, the other sensors used for hybridized positioning. At the replaying stage, the system consists of the device for replaying the recorded data and of the GNSS receiver under test. As with a constellation simulator, the reconstructed signal might be fed to the receiver under test by using a cable or, alternatively, the test might be performed in an anechoic chamber when the antenna cannot be separated from the receiver.

2.4.2 Strengths and weaknesses

The use of re-played scenarios has the significant advantages of being very close to the real world, and therefore, not requiring any error modelling (e.g. for multipath effects) like constellation simulators, and of being perfectly repeatable like pure simulations. Another benefit, that is less obvious despite its interest, is that R&R allows quantification of the GBPT stochastic behaviour. Replaying several times the same recorded scenario will yield slightly different trajectories at the output of the GBPT, the differences between them representing this stochastic behaviour that impact the PVT computation in the real world. Another interesting feature of this approach, for the research labs developing software receivers, is that the raw signal samples collected on site can be stored, transmitted and post-processed, by using different configurations and architectures of the receivers.

However, the use of re-played scenarios has a limitation in the fact that the scenario cannot be changed once the data are collected. In this respect, the choice of the scenarios and the care with which it is recorded are of the utmost importance. Technically speaking, this approach is valuable if the core structures of the data collection system

do not mask or affect the meaningful features of the collected signals, so preserving the information on the specific environment.

This method suffers also from the same problems as laboratory testing in the case of hybridized GPBTs: it is not straightforward to replay synchronously in the laboratory the signal-in-space (SIS) data of the satellites and signals coming from inertial sensors or vision sensors. This needs specific equipment, or accurate error models to be added to signals of the RTMeS, but above all, this requires that the GBPT under test is sufficiently “open” to offer access for the different sensor signals during the replay phase.

2.4.3 Existing equipment

In general, the main constellation simulator manufacturers also produce R&R equipment, e.g. SPIRENT, LabSat, and M3 Systems, with some capable of R&R tests on hybridized GBPT. Further information is given in Appendix B.

2.5 Synthesis

The following table summarizes the strengths and weaknesses of each approach.

Table 7
Strengths and weaknesses of each testing approach

Approach	Cost	Realism	Complexity	Repeatability	Validity for hybrid GBPT
Field tests	High	High	High	Low	High
Lab tests	Low	Low	Medium	High	Medium
Record & replay tests	Medium	High	Medium	High	Medium

The approach adopted will depend on the weight given to each criterion.

For instance, if the device under test is a hybridized “black box”, field tests would be the only approach to choose. These field tests will even be more informative if they are conducted with the target vehicle in the final operational conditions.

If repeatability is essential, lab tests or R&R tests could be used, but if realism is also a top priority, only R&R will be satisfactory.

Conclusion on performance assessment

The aim of these guidelines is to help the stakeholders of ITS and of other application domains in testing the performance of GNSS-based Positioning terminals (GBPT). The positioning performance requirements being application and/or service dependent, different positioning metrics and testing strategies can be used. The three main approaches for testing the performance of positioning systems, field tests, laboratory tests and R&R tests are presented and compared.

Although field tests provide the GBPT performance assessment closest to practical (real life scenario) conditions, they are more complex and time consuming to run than laboratory tests where signals can be broadcast a high number of times at a lower cost. However, nowadays, field tests constitute the only solution to assess the positioning performance of hybrid receivers including various positioning sensors.

R&R testing offers an intermediate approach that is closer to real life positioning conditions since the transmitted signals come from experimental records and they can be repeated many times. However, R&R testing suffers from difficulties (such as synchronization) associated with testing of tightly hybridized terminals.

The selection of the best suitable testing procedure depends on the application/service requirements. Every procedure requires a level of compromise between cost, repeatability, realism and complexity.

The objective of this document is to provide guidelines for adopting the most suitable testing strategy for testing and assessing the positioning performance of GBPTs for the application / service of interest. The general procedures given in this document have meticulously considered the relevant issues of positioning performance requirements and environmental conditions.

References

- [1] F. Peyret, P.-Y. Gilliéron, L. Ruotsalainen and J. Engdahl. COST Action TU1302. SaPPART White paper: Better use of Global Navigation Satellite Systems for safer and greener transport. Ifsttar, 2015. Techniques et méthodes, TMI 1. 58p. ISBN 978-2-85782-707-8.
- [2] F. Peyret and P.-Y. Gilliéron. COST Action TU1302. SaPPART Handbook: Assessment of positioning performance in ITS applications. Ifsttar, 2017. Techniques et méthodes, TMI 2. 77p. ISBN 978-2-85782-727-6.
- [3] CEN-CENELEC EN 16803-1: Use of GNSS-based positioning for road Intelligent Transport Systems (ITS). Part 1: Definitions and system engineering procedures for the establishment and assessment of performances, ICS 49.140, October 2016
- [4] D. Bétaille, F. Peyret, O. Nouvel, W. Vigneau, G. Duchâteau and H. Secrétan, How to produce a reference trajectory for studying GNSS errors in urban environments, ENC GNSS Congress – Toulouse – April 2008.
- [5] M. Ortiz, V. Renaudin, F. Peyret and D. Bétaille, Using a reference vehicle for solving GNSS localization challenges, Inside GNSS – September-October 2013.
- [6] L. Lo Presti, E. Falletti, M. Nicola and M. Troglia Gamba, “Software Defined Radio technology for GNSS receivers” in Metrology for Aerospace (MetroAeroSpace), 2014 IEEE. p. 314-319
- [7] USRP N200/N210 Networked Series. [Online]. Available: https://www.ettus.com/content/files/07495_Ettus_N200-210_DS_Flyer_HR_1.pdf.
- [8] SPAN GNSS Inertial Navigation Systems. [Online]. Available: <https://www.novatel.com/products/span-gnss-inertial-systems/>
- [9] NEO/LEA-M8T u-blox M8 GNSS timing modules. [Online]. Available: https://www.u-blox.com/sites/default/files/products/documents/NEO-LEA-M8T-FW3_ProductSummary_%28UBX-16000801%29.pdf
- [10] Spirent, “In-Vehicle Navigation System (IVNS) Solution Spirent SimAUTO option for Spirent GNSS simulation systems.” [Online]. Available: <https://www.spirent.com/-/media/Datasheets/Positioning/SimAUTO.pdf>. [Accessed: 28-Feb-2017].
- [11] K. Von Hünerbein, P. Argent, T. Schulze, A. Way, and D. Tq, “Multi-Sensor vehicle testing : Recording Inertial Sensors via CAN bus in Combination with Recorded GNSS RF signals,” in Inertial Sensors and Systems Symposium (ISS), 2015, pp. 2377-3480.
- [12] LabSat, “Turntable system,” LabSat TurnTable System, 2017. [Online]. Available: <https://www.labsat.co.uk/index.php/en/>. [Accessed: 07-Mar-2017].

Appendix A: R&R tests based on Software Defined Radio

Technical considerations

An interesting alternative to the R&R based upon specific equipment such as the re-players proposed by the specialized companies, and especially appreciated by research laboratories, is to use the Software Defined Radio (SDR) technology which, in general, refers to an ensemble of hardware and software technologies and design choices that enable reconfigurable radio communication architectures [6].

Figure 6 shows an SDR-based system architecture for GBPT performance testing where it is possible to distinguish the recording and replay of GNSS data, depicted respectively as the green and blue boxes. The different sensors, which might be involved within the GBPT architecture, are thus not considered in this representation. The left part of Figure 6 consists of the live operations to be performed on board of the test vehicle whereas the right part refers to the operations carried out in the laboratory in a second stage.

Figure 6
Overview on whole GNSS signal processing chain

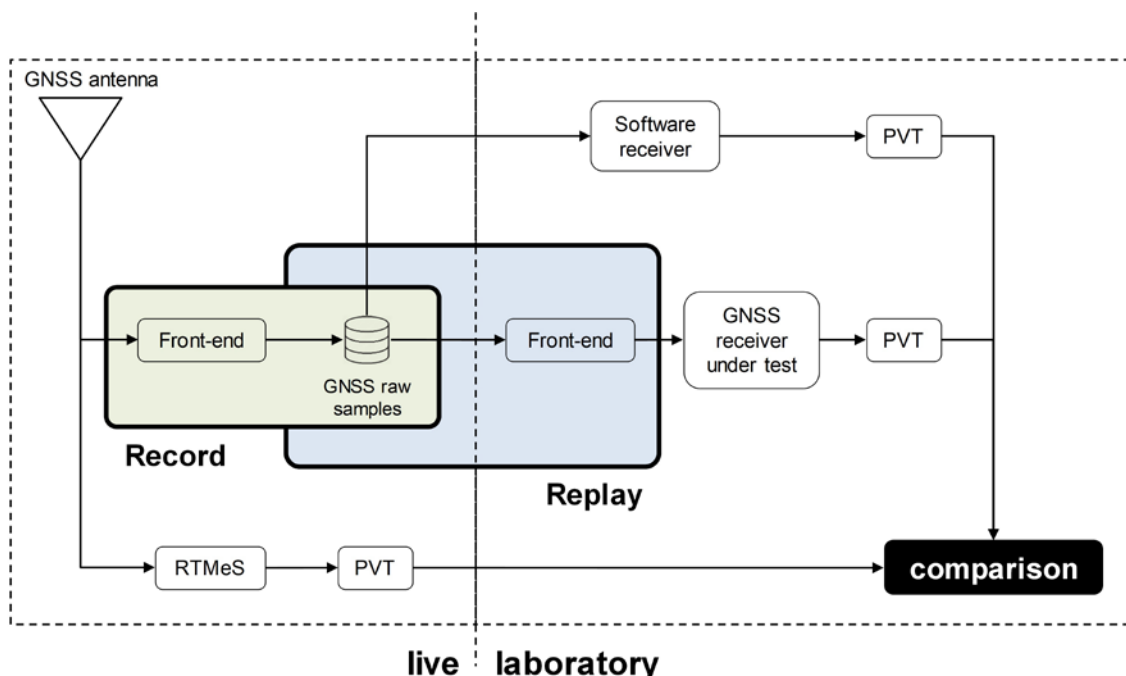

RTMeS: Reference Trajectory Measurement System
PVT: Position, Velocity, Time

Record

The data collection process is performed by the front end, highlighted by the green box in Figure 6. The GNSS RF signal, captured by the antenna, is demodulated at an Intermediate Frequency (IF), where it is sampled and digitalized. The data collection process must be regulated by a very stable clock, in order to achieve consistency of the collected samples. In some cases, it may be necessary to use an external reference clock to steer the clock of the analog to digital converter (ADC), which may not grant the required stability.

Remarks on the raw GNSS sample

The raw data consist of a sequence of digital samples, so called IQ samples, at a certain sampling frequency and represented on a certain number of bits (typically from 1 bit up to 16 bits). However, it is important not to confuse raw GNSS signal samples with GNSS observables, such as the IQ correlation outputs, which are the “raw” outputs of many GNSS commercial receivers (i.e. before using them for pseudorange construction or C/N0 calculation). However, the storage of raw signal samples is not an easy task since it requires large storage capabilities and/or large bandwidth data connections, which are in general, costly resources.

Replay

The blue box in Figure 6 re-generates the GNSS RF signal by replaying its raw binary samples recorded at IF. Starting from the samples, an analogue signal has to be generated by means of a filtering stage and then the signal can be modulated to the original RF frequency. Due to the non-linear quantization process, part of the information is lost during the data collection process. With an appropriate parameter selection, the re-played signal is representative of the real-world GNSS signal.

The re-played signal is then fed into the receiver under test for performance evaluation. It is recommended, at this stage, to use a high quality external reference clock in order not to introduce spurious components in the signal.

Testing a GBPT receiver: a real example

The testing of a GBPT, based on the R&R approach, is presented hereafter by reporting a real test case. Note that in this case only the GNSS sensor is involved within the GBPT architecture. Therefore, data have been collected by means of GNSS raw binary samples together with the reference trajectory obtained by an RTMeS.

Data were collected by a test vehicle, within the city centre of Helsinki (Finland) in November 2016, and then replayed in a second stage in a controlled environment, such as the laboratory.

Equipment used

The front-end used to record the data was the Universal Software Radio Peripheral (USRP) N210 [7]. This device, which has a high level of configurability, was synchronized to a Rubidium frequency standard able to finely control the ADC. The raw GNSS binary samples were thus stored on mass memories. The reference trajectory was obtained by the Novatel SPAN-CPT system receiver [8] which is a compact, single enclosure GNSS receiver hybridized with a navigation grade IMU.

The USRP N210, equipped with a proper duplex daughterboard and synchronized to a Rubidium frequency standard, was also used at the replaying stage to re-generate the RF signal. The latter was fed to a consumer-grade receiver, namely uBlox M8T [9].

The parameters used to acquire the GNSS signal, more precisely GPS and Galileo around the L1 frequency, are listed in Table 8. With these configuration parameters, 1 minute of raw data amounts to 1.2 GB. Note that these parameters were also used for the replaying stage.

Table 8
Parameters of the USRP device

Intermediate frequency	0 Hz (baseband)
Sampling frequency	5 MHz
Sampling type	I and Q sampling
Quantization	12 bits
Interface	Ethernet

Horizontal position error performance assessment

Figure 7 (left) shows the reference and the replayed trajectories respectively as the red and the blue paths. The accuracy metric defined in section 1.1.2 was chosen to assess the receiver performance. Its Cumulative Distribution Function is depicted in Figure 7 (right) for the replayed trajectory with respect to the reference. The three classes are underlined by the black dots and dashed lines. The receiver under test falls into the 2nd class, being a single-frequency stand-alone mass-market receiver (compare with Figure 1).

Figure 7
Left: Reference (blue) and replayed trajectories (red). Right: statistical assessment of the HPE

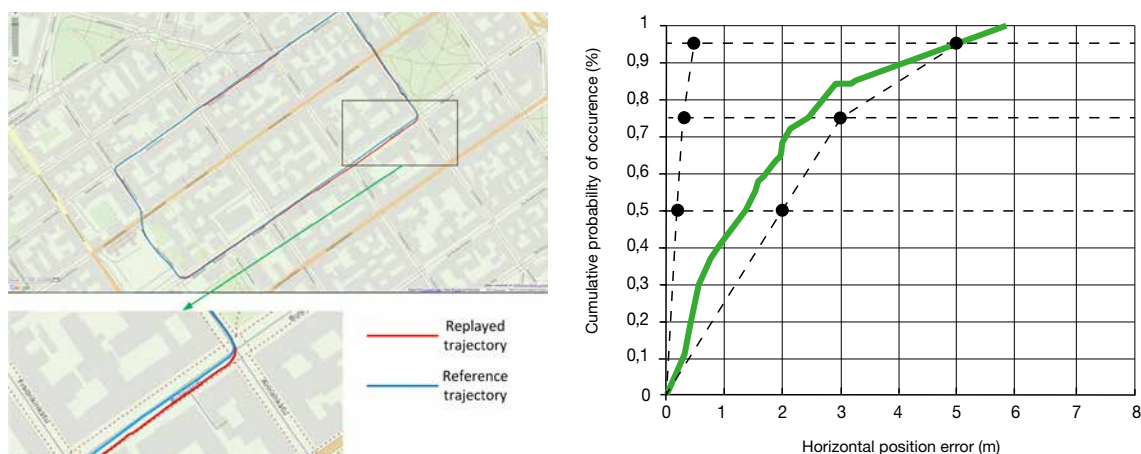

Appendix B: Some examples of specific functions for R&R tests on hybridized terminals

The SimAUTO toolbox [10] from SPIRENT SimGEN software suite enables to simulate vehicles Dead Reckoning data (heading and wheel count sensor outputs, single-axis rate table drive) with a user defined vehicle geometry synchronized with GNSS RF signals.

Hünerbein et al. developed a 6 kg R&R system for multi sensor vehicle testing including CAN bus inertial sensors data, GNSS receiver signals and videos from three cameras [11]. GNSS signals are recorded with the Spirent GSS6425 (GPS, GLONASS, Beidou, Galileo and Augmentation Systems WAAS, EGNOS, MSAT and QZSS, and the SBAS based on Inmarsat). This system is also used to store videos. A Gryphon S4 CAN bus interface stores the vehicle's data. A 2-D axis rate table is embedded to capture heading and pitch changes. A high end inertial navigation system is used to obtain "true" position, velocity and orientation estimates.

LabSat proposes a hybrid navigation system testing solution that comprises a GNSS simulator, a video data logger, a turntable, a yaw rate sensor and a wheel speed generation unit [12]. The system records experimental GPS and GLONASS L1 signals and synchronised vehicle data from the CAN. WAAS/EGNOS can also be recorded. A turntable is then used to replay the data in the simulation phase. The turntable rotates based on the recorded vehicle data simulating the yaw rate of the car. The system is also able to replay synchronized video files (VBOX video) for visual validation purposes of the hybrid position estimates.

List of acronyms

ADC	Analog to Digital Converter
CDF	Cumulative Distribution Function
CEN	Comité Européen de Normalisation/European Committee for Standardization
CENELEC	Comité Européen de Normalisation en Electronique et Electrotechnique/ European Committee for Electrotechnical Standardization
EGNOS	European Geostationary Navigation Overlay Service
GBPT	GNSS-based Positioning Terminal
GLONASS	Global'naya Navigatsionnaya Sputiknovaya Sistema
GNSS	Global Navigation Satellite System
GPS	Global Positioning System
GSA	European GNSS Agency
HPE	Horizontal Position Error
IF	Intermediate Frequency
IR	Integrity Risk
IMU	Inertial Measurement Unit
INS	Inertial Navigation System
ITS	Intelligent transport system
PL	Protection Level
PVT	Position, Velocity and Time
RF	Radio Frequency
RTMeS	Reference Trajectory Measurement System
R&R	Record and Replay
SDR	Software Defined Radio
SIS	Signal-in-Space
TTFF	Time To First Fix
USRP	Universal Software Radio Peripheral
VERT	Véhicule d'Essais et de Référence en Trajectographie
WAAS	Wide Area Augmentation System

List of figures

Figure 1	Performance classes based on technologies for horizontal position accuracy.....	15
Figure 2	The value chain in the road market of GNSS (GSA market study).....	21
Figure 3	Dedicated test vehicle equipped with a Reference Trajectory Measurement System.....	22
Figure 4	Laboratory setup including the simulator on left connected via a cable to a GNSS receiver and a radio front-end.....	22
Figure 5	GNSS Principle of R&R tests on GBPT	23
Figure 6	Overview on whole GNSS signal processing chain	33
Figure 7	Left: Reference (blue) and replayed trajectories (red). Right: statistical assessment of the HPE	35

List of tables

Table 1	Availability classes	14
Table 2	Performance classes based on technologies for horizontal position accuracy	15
Table 3	Performance classes based on applications for horizontal position accuracy	16
Table 4	Performance classes for protection level availability	16
Table 5	Performance classes for horizontal protection level size (consistent with the technologies-oriented classification of horizontal accuracy of Table 2)	17
Table 6	Performance classes for integrity risk	17
Table 7	Strengths and weaknesses of each testing approach	27
Table 8	Parameters of the USRP device	35

Publication data form

Collection techniques and methods		
ISSN 2492-5438	ISBN Print 978-2-85782-740-5 PDF 978-2-85782-741-2	Ref. TMI3
Title SaPPART Guidelines		
Subtitle Performance assessment of positioning terminals		
Author COST Action TU1302		
Sponsor name and address COST Association avenue Louise 149 1050 Brussels Belgium		
Publication date March 2018		Language English
Summary <p>This deliverable, entitled guidelines, is the third outcome of SaPPART COST Action, a European network of scientists and stakeholders that aims to promote smart use of GNSS technology in the field of intelligent road transport and mobility. It discusses the performance assessment of the GNSS-based Positioning terminals (GBPT), which is generally under the responsibility of the system integrators in the road market of GNSS. The aim of this document is to provide guidelines for generic test procedures for the evaluation of GBPT performance, either by field tests, simulations or their combination, compliant with the concepts and the definitions already established in the SaPPART White Paper (TMI 1) and Handbook (TMI 2). The document is intended to provide the reader with a helpful tool for planning the GBPT testing procedures by both discussing the testing in general and by providing some detailed practical information.</p>		
Key words Positioning, GNSS, Performance Assessment		
Number of pages 45		Price free of charge

Fiche bibliographique

Collection techniques et méthodes		
ISSN 2492-5438	ISBN Print 978-2-85782-740-5 PDF 978-2-85782-741-2	Réf. TMI3
Titre Lignes directrices SaPPART		
Sous-titre Évaluation de la performance des terminaux de positionnement		
Auteur COST Action TU1302		
Nom et adresse du financeur COST Association avenue Louise 149 1050 Brussels Belgium		
Date de publication Mars 2018	Langue anglais	
Résumé Ce livrable, intitulé lignes directrices, est le troisième résultat de l'Action COST SaPPART, qui rassemble un réseau de scientifiques et d'acteurs autour de la promotion d'un usage adéquat de la technologie GNSS dans le domaine du transport routier intelligent et de la mobilité. Il traite de l'évaluation de la performance des terminaux de positionnement basés GNSS (TPBG), qui est généralement sous la responsabilité des intégrateurs de systèmes du marché des GNSS pour la route. Le but de ce document est de fournir des lignes directrices pour des procédures de tests génériques en vue de l'évaluation de la performance des TPBG. Cette évaluation peut s'appuyer sur des campagnes de tests, des simulations ou la combinaison des deux, conformément aux concepts et définitions qui ont été établies dans le livre blanc (TMI 1) et le manuel (TMI 2) de SaPPART. Ce document est conçu pour fournir au lecteur une aide à la planification de procédures de tests TPBG en traitant des tests en général et en fournissant des informations pratiques et détaillées.		
Mots clés Localisation, GNSS, évaluation de la performance		
Nombre de pages 45	Prix gratuit	

This deliverable, entitled guidelines, is the third outcome of SaPPART COST Action, a European network of scientists and stakeholders that aims to promote smart use of GNSS technology in the field of intelligent road transport and mobility. It discusses the performance assessment of the GNSS-based Positioning terminals (GBPT), which is generally under the responsibility of the system integrators in the road market of GNSS. The aim of this document is to provide guidelines for generic test procedures for the evaluation of GBPT performance, either by field tests, simulations or their combination, compliant with the concepts and the definitions already established in the SaPPART White Paper (TMI 1) and Handbook (TMI 2). The document is intended to provide the reader with a helpful tool for planning the GBPT testing procedures by both discussing the testing in general and by providing some detailed practical information.

Ce livrable, intitulé lignes directrices, est le troisième résultat de l'Action COST SaPPART, qui rassemble un réseau de scientifiques et d'acteurs autour de la promotion d'un usage adéquat de la technologie GNSS dans le domaine du transport routier intelligent et de la mobilité. Il traite de l'évaluation de la performance des terminaux de positionnement basés GNSS (TPBG), qui est généralement sous la responsabilité des intégrateurs de systèmes du marché des GNSS pour la route. Le but de ce document est de fournir des lignes directrices pour des procédures de tests génériques en vue de l'évaluation de la performance des TPBG. Cette évaluation peut s'appuyer sur des campagnes de tests, des simulations ou la combinaison des deux, conformément aux concepts et définitions qui ont été établies dans le livre blanc (TMI 1) et le manuel (TMI 2) de SaPPART. Ce document est conçu pour fournir au lecteur une aide à la planification de procédures de tests TPBG en traitant des tests en général et en fournissant des informations pratiques et détaillées.



Funded by the Horizon 2020 Framework Programme of the European Union



LES COLLECTIONS DE L'IFSTTAR

ISSN: 2492-5438

Ref: TMI 3

Photo credit:

Pierre-Yves Gilliéron - EPFL

March 2018