

Analysis of the communication anomaly during E-ST@R-2 mission operations

Original

Analysis of the communication anomaly during E-ST@R-2 mission operations / Corpino, S.; Stesina, F.. -
ELETTRONICO. - (2017). ((Intervento presentato al convegno 68th International Astronautical Congress, IAC 2017
tenutosi a Adelaide, Australia nel 2017.

Availability:

This version is available at: 11583/2704969 since: 2018-04-04T09:57:45Z

Publisher:

International Astronautical Federation, IAF

Published

DOI:

Terms of use:

openAccess

This article is made available under terms and conditions as specified in the corresponding bibliographic description in
the repository

Publisher copyright

(Article begins on next page)

IAC-17.B4.3.3

ANALYSIS OF THE COMMUNICATION ANOMALY DURING E-ST@R-2 MISSION OPERATIONS

S. Corpino ^{a*}, F. Stesina ^a

^a Department of Mechanical and Aerospace Engineering, Corso Duca degli Abruzzi 24, Torino, Italy,
sabrina.corpino@polito.it

^b Department of Mechanical and Aerospace Engineering, Corso Duca degli Abruzzi 24, Torino, Italy,
fabrizio.stesina@polito.it

* Corresponding Author

Abstract

To increase probability of success of future nanosatellite missions, data gathered from orbit operations are of paramount importance, especially if anomalies are observed. E-st@r-2 Cubesat was launched on April 2016 in the framework of the Fly Your Satellite! programme of the European Space Agency. Few anomalies were detected during operation, which compromised the mission either temporary or permanently. This paper describes the investigation of a major anomaly that seriously affected mission operations, i.e. low Signal-to-Noise ratio of downlink communication. In particular, no signal could be received at the main control station. Only ground stations with high gain antennas and/or proper system set up could receive and decode e-st@r-2 packets, whereas standard radio amateur station failed. For this reason, both space and ground segments were identified to be part of the problem. The analysis performed to cope with the issue covered several phases of mission lifecycle, from design to assembly, integration and test, until operations. The investigation on the anomaly has been done by means of analysis and test activity. A loss of 12 to 15 dB was estimated with respect to the link budget. A fault tree analysis was developed to identify the failure or combination of failures that resulted in the mishap. A failure modes and effects analysis of communication system was carried out, as this subsystem was identified as the major contributor to the anomaly. In parallel, testing activity was performed on the engineering model of cubesat. A thorough test campaign was planned and executed at equipment, subsystem and system level. Test results on the engineering model were compared with orbit data and results of qualification campaign on the flight unit. The investigation showed that possible causes of the anomaly could be either incomplete deployment of the antenna, or incorrect antenna connection, or loss of power in the transceiver, or a combination of these causes amplified by the tumbling motion of the CubeSat. Taking into account the extensive test campaign executed on the flight unit during development, the failures of antenna deployment and of high-power amplifier circuit are extremely unrealistic. Instead, a potential defect was detected on the coaxial cable connection to the antenna, which might have caused the final mishap under investigation. The analysis also showed that an effective ground segment helps mitigating the impact of the anomaly, thus increasing mission success to a great extent, and it is worth investing more on this mission element.

Keywords: Operations anomaly analysis, Cubesat in-orbit operations, Communications systems, Fault Tree analysis, Root causes analysis.

Acronyms/Abbreviations

ADCS = Attitude Determination and Control System
AFSK = Audio Frequency Shift Keying
AIV = Assembly Integration and Verification
COM SYS = COMmunication SYStem
EIRP = Effective Isotropic Radiated Power
EM = Engineering Model
EPS = Electrical Power System
FM = Flight Module
GS = Ground Station
HPA = High Power Amplifier
IMU = Inertial Measurement Unit
LNA = Low Noise Amplifier
MT = MagneTorquer
OBC = On Board Computer

R F= Radio Frequency
TNC = Terminal Node Controller

1. Introduction

Until the last years, the space community identified CubeSats as an excellent education and training system. Universities around the world foresaw educational programs based on the development of Cubesats, sometimes supported by Space Agencies [1], [2].

In the last years, CubeSats are gaining increased attention within the space industry and government due to their essential “low cost and fast delivery” paradigm. The space community believes that CubeSats can contribute to a broad set of goals, even far off Earth [3], if supported by the appropriate set of technologies (i.e. advanced communication systems with higher data rate

[4], precise attitude control and navigation, and effective propulsion systems [5]), and increased reliability both at mission and system level.

As demonstrated in [6], less than 50% of the launched cubesats (especially with educational purposes) were/are able to successfully complete their intended mission. Among the cubesats that sent signal to Ground Stations, some reached only degraded or limited performances. Data gathered from orbit operations are of paramount importance, especially if anomalies are observed, for the development of future missions.

E-st@r-II (Fig. 1) was selected within the ESA initiative called *Fly Your Satellite!* as one of the three cubesats launched on April 25th 2016 during a Soyuz launch.

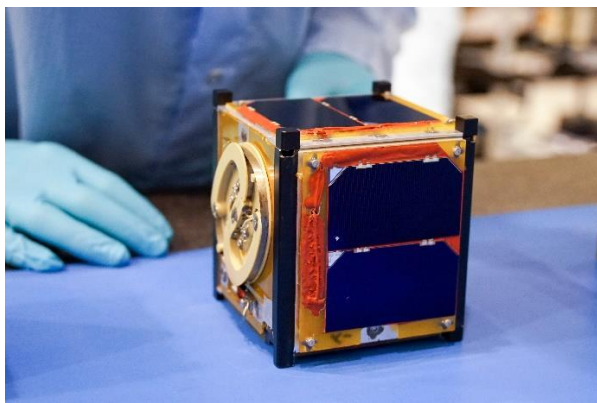

Fig. 1: E-st@r-II before integration in the P-POD

E-st@r-II is still operative after the end of the nominal mission duration (one year). However, during the in-orbit operations, e-st@r-II mainly performed the planned mission but some anomalies were observed from the communication point of view, that limited the data collection and partially prevented to completely accomplish the mission. Gathered data and post-processing analyses, documentation reviews and special tests permitted to investigate the origins of the anomalies and allowed implementing corrective actions, and gaining experience for future projects.

The present paper deals with the root causes analysis of the communication anomalies of e-st@r-II cubesat. Section 2 describes the methodology, Section 3 proposes the analysis and the related results that led to identifying the root causes of the anomalies, and Section 4 highlights the importance of the analysis and traces some remarks and lessons learnt.

2. Methodology

The methodology followed for the e-st@r-II anomaly analysis takes inspiration from [8], tailoring the more general aspects to the case of a small-size space system developed at university level.

An anomaly occurs when a system does not meet its requirements. A systems failure analysis is an investigation to determine the underlying reasons for the non-conformance to system requirements. A systems failure analysis is performed to identify non-conformance root causes and to recommend appropriate corrective actions.

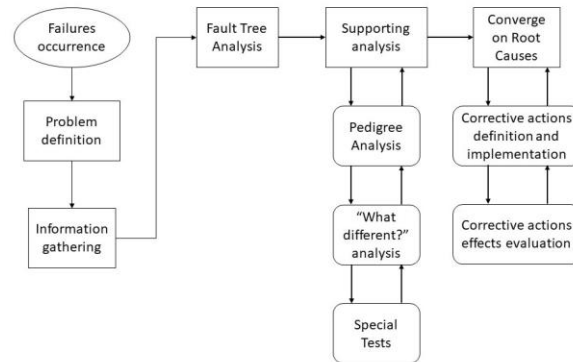

Fig. 2: Failure Analysis Process

Fig. 2 shows the approach for the analysis of the anomalies followed for the present case of study. This analysis begins with a clear understanding of the failures, the determination of their occurrence and context, and their severity. The second step is to identify all the sources of information such as data from real-time or post-processed telemetry or from process documentation that can provide support to the analysis. Once this has been accomplished, all potential failure causes are identified using fault tree analysis. The process then evaluates each of the potential failure causes also using support analyses, including *what's different* analysis, *pedigree* analysis, and special tests and experiments. *What different* analysis leads to identify changes that might have induced the anomaly. The basic premise of this analysis is that the system has been performing satisfactorily until the failure occurred; therefore, something must have changed to induce the failure. Potential changes include system design, manufacturing processes, suppliers, operators, hardware lots, operative environment. Pedigree analysis examines all the documentation related to the components and subassemblies, all the AIV steps and results. Pedigree analysis involves studying this documentation (such as test data, inspection data, raw material data sheets, and other certifications) to determine if components and subassemblies identified in the fault tree meet the requirements. Special tests and experiments include tests designed to investigate nominal and off-nominal conditions on a representative model of a component, a subsystem or the whole system. Tests designed in nominal conditions serve to examine in depth special

features not considered during the AIV campaign. Tests designed inducing a failure permit to evaluate a hypothesized failure cause. Fault tree analysis and support analyses should rule out the major parts of the identified causes and converge on few root causes for each anomaly. The final step is to review (and sometimes relax) the requirements and/or select and implement corrective actions that eliminate or mitigate the anomaly.

3. Analysis and results

Est@r-II cubesat experienced communication anomalies during the operative life. The observed failures can be labelled as critical events because they seriously affected the mission and had a major impact on the mission objectives.

During the mission, three main behaviours are observed:

- orbits in which ARI-BRA ground station (GS) did not receive signals from the satellite but other stations, both radio-amateur stations and/or high performance stations (such as Dwingeloo Telescope), received signals. That led to review the ARI-BRA setup and to intensify and open new cooperation with other stations.
- orbits in which radio-amateur ground stations did not receive signals while Big Dish Stations received signals. This led to investigate the possible causes of anomaly on the satellite Communication subsystem equipment (i.e antenna system command chain) and components (i.e radiomodule HPA and LNA, antenna pieces, transistors, cables/wires, connectors), in particular on the communication chain.
- orbits in which no stations received signals. In this case, failures analysis was focused on the entire satellite.

3.1 Problem definition

From these observations, three top events have been identified as communication anomalies:

1. No signal is received by Ground Station(s)
2. Low signal to noise ratio
3. Satellite does not execute commands

3.2 Sources of information

Main sources of information are:

- telemetry data from the satellite: time from last reboot, voltage, current and temperature on solar panels and batteries, on-board power consumptions, angular velocities, subsystem status bytes

- post processing information such as orbit position when packets/signals are received, eclipse duration and time from last eclipse when packet/signal is received, slant range when packet/signal is received, and signal strength: power of the signal in dB and S/N ratio
- analysis of the AIV test campaign data.

Table 1: event description and occurrence

Event	Description	Occurrence
No signal is received at GSs	GSs does not receive signals from satellite for a period of time.	The anomaly is intermittent without an evident periodic occurrence scheme.
Low signal to noise ratio	AFSK signal in input to Ground Station MODEM is too low to be decoded (it is received but not decoded by the GSs)	Anomaly has high occurrence. The received signals are always lower than expected. Although the decoding operations are always possible if Big Dish stations receive the data, radio-ham stations (included ARI-BRA) seldom accomplish the validation and decoding process of the packet.
Satellite does not execute commands	Satellite does not react to commands sent by GSs	This anomaly is intermittent but with high occurrence: the satellite rarely reacts to the command sent by ARI-BRA. Moreover, attempts to send commands with Big Dish Station dis not have 100% of success

3.3 Fault Tree Analysis

Fig. 3, Fig. 4, and Fig. 5 show the top parts of Fault Trees for the defined anomalies.

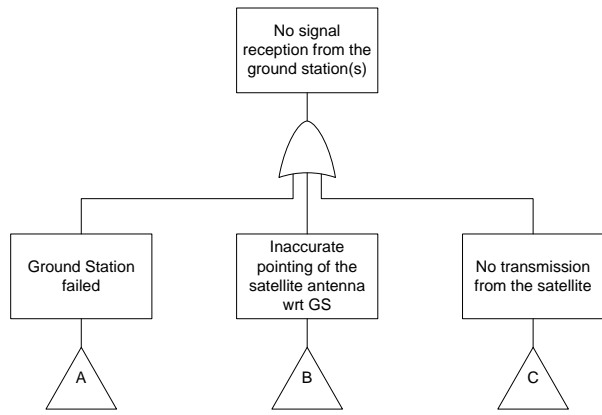

Fig. 3: FT for the top event “No signal reception from the ground station(s)”

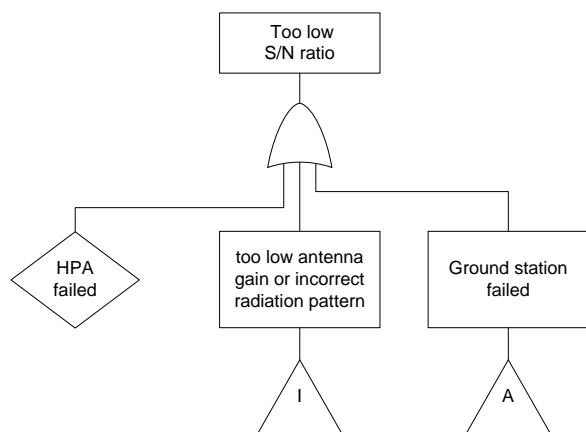

Fig. 4: FT for the top event “Too low S/N ratio”

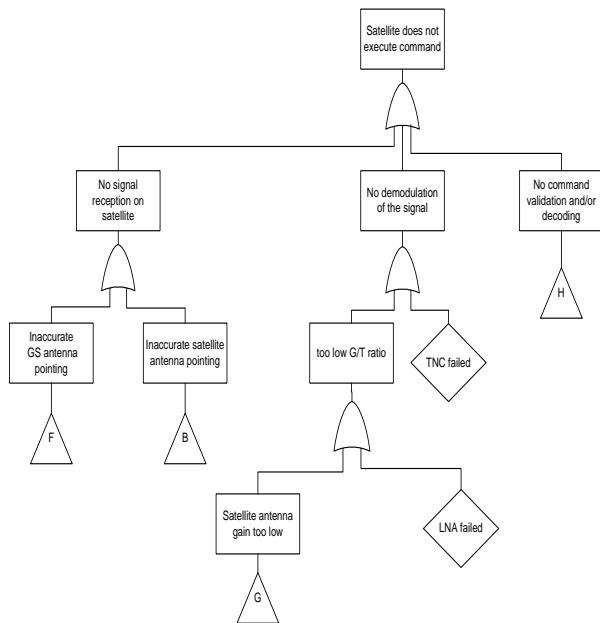

Fig. 5: FT for the top event “Satellite does not execute command”

3.4 Support analyses

The main differences between AIV campaign and the operative phase in orbit are:

- in orbit conditions in terms of:
 - radiation environment can cause single event phenomena and progressively increases the Total Ionizing Dose acting on the satellite;
 - temperature of the on-board components can reach out of nominal values that temporary or permanently compromise their capabilities.
- distance between Satellite and Ground Station that means:
 - antenna tracking for ground station and antenna pointing for the satellite were not required during AIV campaign
 - signal was always strong enough to receive and decode it during AIV campaign
- long duration of the mission with respect to tests: all AIV campaign tests had a limited duration due to necessity of recharging the battery because solar panels could not provide sufficient energy in laboratory conditions: the maximum duration of the tests on the fully integrated satellite was about 12 hours. Similarly, tests led in HIL configuration present two important differences with respect to the mission conditions: first, the duration was anyway shorter (max duration: 30 hours) and satellite was not in the final, all integrated configuration.

Pedigree analysis is based on the Acceptance Data Package documents and all the test reports such as HIL verification campaign, full functional tests in laboratory conditions, Mission test and Functional tests during the environmental tests in thermal-vacuum chamber, and antenna deployment verification.

Special experiments have been designed and performed for the purpose of the anomaly analysis. In particular,

- Tests on Radio-module Engineering Model (EM) output power: tests highlight that the EM of the BHX2 radio-module effectively produces 500 mW power signal. No test was performed for the verification of the RF output power of the Flight radio-module and the fully integrated system;
- Test on the COM SYS EMs to verify the signal power in different nominal and off-nominal

configurations: test highlights a difference from 12 dB to 18 dB between signal sent with antenna deployed and signal with antenna not deployed.

3.5 Root causes

The “absence of signal” can be due to Ground station or satellite failures. Single or multiple failure(s) on ground station parts and/or the low performance of some components are considered. Mismatch polarization of the signal (generating a signal attenuation less than 0.3 dB) and the line losses between the antenna and transceiver (generating an estimated signal attenuation of less than 3 dB) cannot justify a loss of signal power so high to cause the complete lack of signal reception. An inaccurate GS antenna pointing provides a signal attenuation proportional to the antenna beamwidth and the actual misalignment of the antennas beams. Considering a beamwidth of 35° for the YAGI antenna and a maximum pointing error of 10°, the attenuation is about 1 dB. Neither this value justifies the complete lack of signal. The 2 meters, 16-elements YAGI antenna provide a theoretical gain of 14 dB: a more performant antenna can contribute to improve the S/N ratio but link margin computation shows that the link should be closed with the gain and beamwidth of this antenna.

The bad pointing of the satellite antenna depends on the velocity of release from the P-POD, environmental conditions (i.e. disturbance torques), and the missed activation of the ADCS or a/more failure(s) of its components. All these conditions affect the satellite attitude. Data analysis of the telemetry confirms that the satellite maintains a slow tumbling motion. The quasi-permanent de-activation of ADCS caused that the release energy from P-POD and/or the kinetics energy due to antenna deployment was not dumped and the satellite tumbles. Moreover, satellite remains under the disturbance torques effects without control. As a consequence, bad pointing of the satellite antenna generates a signal attenuation, determined through equation $L_{pr} = \left(\frac{\text{pointing error}}{\text{beamwidth}}\right)^2$. Knowing that a dipole beamwidth is about 160°, Table 2 shows how a high misalignment generates a high attenuation that can both prevent the reception of the signal on ground (if the antenna has a pointing close to the zenith) or reduce signal strength avoiding an efficient decoding process.

The missed reception of signal by all the ground station can occur when the satellite transmission is stopped because the activation phase is still not completed or one of the specific commands to stop the transmission are sent by the GS. The first event has not a negligible probability of occurrence due to the anomalous high number of reboots. Commands stopping the transmission are never activated at this

moment so that this cause is excluded. On the contrary, it is possible that the satellite cannot transmit because a failure in the transmission chain components (such as antenna, HPA or TNC) occurs. It could be not excluded that TNC could temporary fail in hardware or in software. A HPA failure is hard to investigate due to the limited information about the design of the COTS radio-module from the datasheets.

Table 2: signal attenuation for misalignment error of the satellite

Pointing error (deg)	L _{pr} (dB)
10	0,05
30	0,42
45	0,95
60	1,68
90	3,8
120	6,75
150	10,5

A lack of communication between OBC and COM SYS can occur but is not sufficient to prevent the transmission. In fact, a beacon CW signal is sent unless one of the RF equipment fails. On the contrary, a lack of communication between OBC and COM SYS is sufficient to prevent the transmission of AFSK signals. A lack of transmission can occur if the satellite switched-off because the system buses (3.3 Volt bus, 5 Volt bus, and battery bus) are not powered. During the period of time in which satellite orbits have regular eclipse periods, the telemetry shows nominal values of battery voltage. When satellite remains in daylight conditions for long time, the received telemetry confirms that the batteries work at almost maximum voltage. These considerations permit to exclude satellite switch off for batteries under-voltages. Moreover, the gathered EPS telemetry does not present anomalies thus permitting to give a low probability to the I2C node failure event. Temporary failure on the EPS components such as solar panels, battery charge regulators, voltage regulators, cannot be completely excluded but all the telemetry packets related to these components show nominal values and their probability of misbehaviour is very low. On the contrary, off-nominal operative temperatures on satellite components (such as batteries) cannot be excluded because some telemetry packets highlight values very close to the upper limits. High internal temperatures are a probable cause of the satellite switch-off. In this sense, tests confirm that e-st@r-II should work properly in the operative conditions tested during the thermal-vacuum test campaign but we have no data about the behaviour of the satellite for off-nominal thermal conditions inside the satellite.

To conclude, the absence of received signal on ground is mainly due to the bad pointing of the satellite to nadir and the high attenuations due to bad

connections, and by the temporary switch-off of the transmissions due to the activation phase activities. To mitigate the ARI-BRA GS problems, some corrective actions were implemented such as the accurate review of the connections and the change of some coaxial cables, the change of the antenna (YAGI 3-meters long with 16 elements), the insertion of a circular polarization switch with a higher quality component, and the re-calibration of the antenna tracking system. The “low S/N ratio” is due to 1) a failure of the radio-module, and 2) an incomplete radiation pattern and/or a low gain of the antenna.

1. It is not easy to estimate the attenuation of the signal in case of failure of the radio-module from data-sheet. Theoretical computation shows that a reduced amplification of 10 times (50 mW instead of 500 mW) generates an attenuation of the output signal power of 10 dB; a reduced amplification of 100 times (5 mW) generates an attenuation of 20 dB. These values are compatible to explain the observed anomaly. Test on EM radiomodule cannot exclude a failure on FM. Possible causes of the failure are:

- space environment: single events can have permanently modified the HPA settings or compromised other internal components. In this case, it seems less probable because it would mean that the radiation hit the satellite in the first 30 minutes after the release or during the launch phases.
- A fault during the production phase of the radio-module not identified during the AIV campaign. However, the difficulty on the commands reception (see next section) implies the failure also of the LNA of the radio-module. There is low probability that both LNA and HPA contemporary fail unless the module is not correctly powered.

2. Incomplete radiation pattern can be caused by a faulty connection during the integration phase: a wrong connection between the coaxial cable and the two antenna pieces. Photos taken during integration (Fig. 6) show that two twisted cables are used to lengthen the connection in order to ease the integration. As these cables are not coaxial, this configuration does not behave as a transmission line, instead these cables cause a significant loss and, as consequence, the antenna has not a main lobe but several side lobes, that fall down power and reduce gain and beamwidth.

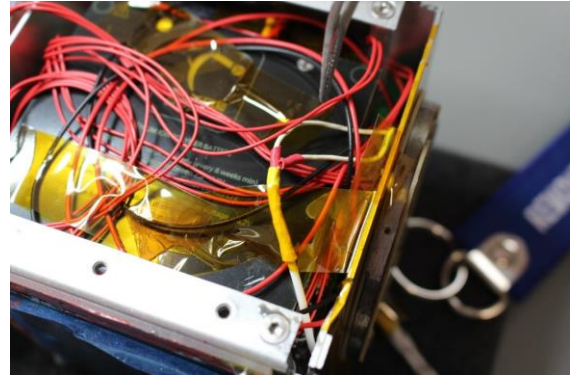

Fig. 6: Details of the antenna connection

A second cause of incomplete antenna pattern and/or reduced antenna gain is a failure on the antenna opening circuit lines that prevents the antenna deployment. The antenna opening circuit (Fig. 7) presents a redundancy by design: two independent circuits (based on two cascades of three MOSFET) contribute to cut the fishing wire. This redundancy allocates a low probability of failure occurrence because it would mean that both lines failed either during the launch or in the first 30 minutes of the mission.

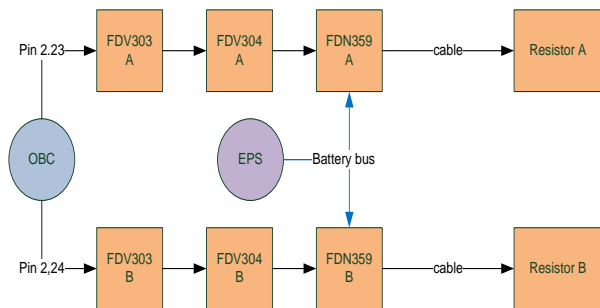

Fig. 7: antenna opening circuit block scheme

Moreover, the antenna opening procedure is repeated every 45 minutes in nominal conditions. During the development phase, partial antenna opening occurred due to an incomplete burning of the fishing wire. However, the defect was fixed changing the dimension of the wire and the duration of the burning time. During the final AIV campaign no major failures were observed on the antenna deployment system. However, the antenna deployment operations are stressful for the opening circuits and the continuous repetitions can seriously compromise the capability to cut the fishing wire.

Possible causes of missed antenna deployment are:

- An incorrect closing of the antenna on its support so that the fishing wire does not touch both the resistors contemporary. However, the picture in Fig. 8 taken immediately before the satellite integration in the P-POD, should exclude this event;
- The fishing wire was moved away from the resistors during the launch: the possibility of occurrence of this event could not be unwrapped.

A third cause of failures in the antenna is the damage of the steel pieces. However, this event should be derived from a multiple failure:

- Antenna was accidentally opened within the P-POD and one or both the pieces were torn off
- The steel was degraded and the energy of the release or the launch vibrations caused a damage.

These multiple failures have very low probability of (contemporary) occurrence.



Fig. 8: detail of the antenna system

To conclude, the bad connection between the antenna and the COM SYS board is considered the most probable cause for the difficulty to decode the AFSK packets because it introduces both a strong reduction of the EIRP and a wrong or incomplete radiation pattern with a smaller main lobe and higher number and strong side lobe.

The “missed execution of commands” can be caused by the missed signal reception by the satellite, the high line losses attenuation between antenna and transceiver, the failure in TNC line, and the lack of demodulation, validation and/or decoding of the command.

The bad pointing of the GS antenna that produces an attenuation of about 1 dB should not generate missed signal. On the contrary, an inaccurate pointing of the satellite generates a high attenuation of the signal until the loss of the link when the satellite antenna face points to zenith. Inaccurate pointing of the satellite is probable because no attitude control acts on the satellite until ADCS is activated. A failure of one or more LNA components cannot be identified from radio-module data-sheet. However, it seems less probable that both LNA and HPA contemporary fail unless the module is not correctly powered.

A faulty connection between the coaxial cable and the two antenna pieces generates high line losses. Two twisted cables are used to lengthen the connection in order to ease the integration. As these cables are not coaxial, this configuration does not behave as a transmission line instead these cables cause a significant loss and, as consequence, antenna has not a main lobe but several side lobes, that fall down power and reduce gain and beamwidth.

The TNC temporary failure for a SEU or a bug in the software should be taken into account. These failure causes are excluded but, according to the planned procedures, a command is sent only after the reception of an AFSK packet. It implies that TNC software works properly because it correctly modulates the signal. Moreover, although the command is not executed, the satellite correctly transmits another AFSK telemetry packet correctly after 2 minutes from the previous one, confirming that TNC still works. Similarly, a failure of the OBC or of the communication between COM SYS and OBC, should prevent both uplink and downlink of AFSK signal. Unless uplink tasks on the OBC are stopped, downlink tasks still work and the watchdog circuit does not intervene: this condition never occur during the development tests and the AIV campaign.

Lack of demodulation of the signal means that the TNC cannot extract the base-band signal from the received wave. It can be due to a failure on the TNC or a S/N ratio value too low.

A low antenna gain can be caused by the missed or partial deployment of the antenna or the steel antenna pieces are broken. However, both the failures have a low probability of occurrence thanks to redundancy of opening circuits.

To conclude, the main causes of the missed execution of the command is ascribed to the inaccurate pointing of the satellite and the low value of the G/T ratio. This cause is mainly due to low gain of the antenna generated by the faulty connection of the antenna with the COM SYS board and/or the missed or partial deployment of the antenna.

4. Conclusions

e-st@r-II experienced anomalies on the communications during the in-orbit operations. In particular, the signal strength is too low and sometimes the reception neither on ground nor on the satellite is possible. A root causes analysis has been performed and allowed to converge on few root causes: wrong cable connection that increases the attenuation and changes the radiation pattern, bad pointing of the satellite to nadir and, sometimes, orbit conditions (i.e. high temperature).

Analysis of the anomalies of e-st@r-II mission leads to important considerations and remarks for future programmes. The design of the satellite shall foresee on-board redundancy and functions partitioning. The use of on board resources should be maximized: for example, the increasing number of on board micro-processors could provide hot redundancy on vital and critical functions such as beacon signal transmission, housekeeping and mission data storage, operative modes management. A distributed architecture improves reliability with respect to the centralized architecture that constitutes the basic architecture implemented in e-st@r-II, often without requiring additional hardware. During the assembly, integration and verification activity, attention shall be posed to HW interfaces assembly. Any connection shall be robust, and high quality of connectors is required; selected cables shall be appropriate and their length and patch shall be defined in order to limit interferences and losses of signal power, and each component shall be robustly fixed using screws, glues, and tapes to avoid unsafe movements especially during the launch phase. Verification campaign should be led looking for the reproduction of the operative conditions, for example using ground support equipment to stimulate the Cubesat through adequate models and perform HIL simulations as much as possible. When this kind of verifications is not applicable, representative tests shall be thought (i.e. long-distance communication that consists of line-of-sight communication tests between GS and satellite with a distance of kilometres) and the results properly scaled. Great importance has the documentation of the AIV process in terms of rigorous procedures definition and results recording. A planned sequence of simple steps facilitates setup, data gathering, and post processing analysis. For example, any step of the assembly and integration should be documented with pictures or sketches paying attention to critical details.

Finally, Ground Segment covers an important role in any phase of the programme, especially during the operations. Often the tendency is to underestimate this role and the efforts, resources and time spent for ground station performance, setup and verification are not sufficient. Moreover, for educational missions, the support of radio-amateur network is fundamental because a wider coverage can be reached increasing the availability of the satellite signals.

References

- [1] Galeone P. C., Walker R., Gupta V., Kinnaird A., Vannitsen J., Cubesats launched on the Vega qualification flight., Portoroz : 4S Symposium, 2012.
- [2] Fly Your Satellite! program. ESA. [Online] http://www.esa.int/Education/CubeSats_and_Education_the_Fly_Your_Satellite!_programme (access 30.04.2017)
- [3] Viscio, M.A., Viola, N., Corpino, S., Stesina, F., Fineschi, S., Fumenti, F., Circi, C., Interplanetary CubeSats system for space weather evaluations and technology demonstration, *Acta Astronautica*, 104 (2), pp. 516-525, 2014
DOI: 10.1016/j.actaastro.2014.06.005
- [4] Klofas B., Anderson J., Leveque K., A survey of Cubesat communication systems., *CubeSat Developers Conference*, San Louis Obispo, 2008.
- [5] Mueller J., Hofer R., Ziemer J., Survey of propulsion technologies applicable to CubeSats, Jet Propulsion Laboratory, NASA, 2010. <http://hdl.handle.net/2014/41627> (access 28.08.2017)
- [6] Statistical reliability analysis of satellites by mass category: Does spacecraft size matter? Dubos, G. F., Castet, J.-F., and Saleh, J. H. 5-6, *Acta Astronautica*: Elsevier, 2010, Vol. 67.
- [7] Stesina, F., Corpino, S., Feruglio, L., An in-the-loop simulator for the verification of small space platforms, (2017) *International Review of Aerospace Engineering*, 10 (2), pp. 50-60, DOI: 10.15866/irease.v10i2.10593
- [8] http://www.jhberkandassociates.com/systems_failure_analysis.htm, (access 31.08.2017)