



From Knowledge to Wisdom

ISSN 1934-7359 (Print)
ISSN 1934-7367 (Online)
DOI:10.17265/1934-7359

Journal of Civil Engineering and Architecture

Volume 11, Number 11, November 2017



David Publishing Company
www.davidpublisher.com

Journal of Civil Engineering and Architecture

Volume 11, Number 11, November 2017 (Serial Number 120)



David Publishing Company
www.davidpublisher.com

Publication Information:

Journal of Civil Engineering and Architecture is published monthly in hard copy (ISSN 1934-7359) and online (ISSN 1934-7367) by David Publishing Company located at 616 Corporate Way, Suite 2-4876, Valley Cottage, NY 10989, USA.

Aims and Scope:

Journal of Civil Engineering and Architecture, a monthly professional academic journal, covers all sorts of researches on structural engineering, geotechnical engineering, underground engineering, engineering management, etc. as well as other issues.

Editorial Board Members:

Dr. Tamer A. El Maaddawy (Canada), Prof. San-Shyan Lin (China Taiwan), Dr. Songbai Cai (China), Prof. Vladimir Patricevic (Croatia), Dr. Sherif Ahmed Ali Sheta (Egypt), Prof. Nasamat Abdel Kader (Egypt), Prof. Mohamed Al-Gharieb Sakr (Egypt), Prof. Marina Traykova (Bulgaria), Prof. Olga Popovic Larsen (Denmark), Prof. George C. Manos (Greece), Dr. Konstantinos Giannakos (Greece), Pakwai Chan (Hong Kong), Chiara Vernizzi (Italy), Prof. Michele Maugeri (Italy), Dr. Giovanna Vessia (Italy), Prof. Michele Di Sivo (Italy), Prof. Valentina Zileska-Pancovska (Macedonia), Dr. J. Jayaprakash (Malaysia), Mr. Fathollah Sajedi (Malaysia), Prof. Nathaniel Anny Aniekwu (Nigeria), Dr. Marta Słowik (Poland), Dr. Rafael Aguilar (Portugal), Dr. Moataz A. S. Badawi (Saudi Arabia), Prof. David Chua Kim Huat (Singapore), Dr. Ming An (UK), Prof. Ahmed Elseragy (UK), Prof. Jamal Khatib (UK), Dr. John Kinuthia (UK), Dr. Johnnie Ben-Edigbe (UK), Dr. Yail Jimmy Kim (USA), Dr. Muang Seniwongse (USA), Prof. Xiaoduan Sun (USA), Dr. Zihan Yan (USA), Dr. Tadeh Zirakian (USA), Dr. Andrew Agapiou (UK).

Manuscripts can be submitted via Web Submission, or e-mailed to civil@davidpublishing.com or civil@davidpublishing.org. Submission guidelines and Web Submission System are available at <http://www.davidpublisher.com>.

Editorial Office:

616 Corporate Way, Suite 2-4876, Valley Cottage, NY 10989, USA

Tel: 1-323-984-7526, 323-410-1082 Fax: 1-323-984-7374, 323-908-0457

E-mail: civil@davidpublishing.com; civil@davidpublishing.org; shelly@davidpublishing.com

Copyright©2017 by David Publishing Company and individual contributors. All rights reserved. David Publishing Company holds the exclusive copyright of all the contents of this journal. In accordance with the international convention, no part of this journal may be reproduced or transmitted by any media or publishing organs (including various websites) without the written permission of the copyright holder. Otherwise, any conduct would be considered as the violation of the copyright. The contents of this journal are available for any citation. However, all the citations should be clearly indicated with the title of this journal, serial number and the name of the author.

Abstracted/Indexed in:

Cambridge Science Abstracts (CSA)

Ulrich's Periodicals Directory

Chinese Database of CEPS, Airiti Inc. & OCLC

Summon Serials Solutions, USA

China National Knowledge Infrastructure (CNKI)

Turkish Education Index

Google Scholar

ProQuest, USA

J-Gate

Subscription Information:

\$720/year (print)

David Publishing Company

616 Corporate Way, Suite 2-4876, Valley Cottage, NY 10989, USA

Tel: 1-323-984-7526, 323-410-1082 Fax: 1-323-984-7374, 323-908-0457

E-mail: civil@davidpublishing.com; civil@davidpublishing.org; shelly@davidpublishing.com

Digital Cooperative Company: www.bookan.com.cn



David Publishing Company
www.davidpublisher.com

Journal of Civil Engineering and Architecture

Volume 11, Number 11, November 2017 (Serial Number 120)

Contents

Sustainable Research

- 979 **Development of APEC Low-Carbon Town (LCT-I) Indicator System**
Yuko Tanaka and Kazutomo Irie
- 993 **Probability Theory Use in Hydrology (Sitnica River Shed)**
Zekirija Idrizi, Isak Idrizi and Kujtim Zena
- 1004 **Hydropower Energy Source Combining with Other Renewables in the Territory of Kosova**
Zekirija Idrizi, Isak Idrizi and Kujtim Zena

Urban Planning

- 1014 **Crowd Monitoring System Using Unmanned Aerial Vehicle (UAV)**
Ali Al-Sheary and Ali Almagbile
- 1025 **Analysis of Pedestrian Facilities in CBD Area of Pabna Municipality, Bangladesh**
Md. Saiful Islam and Md. Sohel Rana
- 1038 **Space for Cooking in Housing Architecture**
Simona Canepa

Space for Cooking in Housing Architecture

Simona Canepa

Department of Architecture and Design, Politecnico di Torino, Torino 10125, Italy

Abstract: The preparation and cooking of food is part of everyday life from the moment in which man began to cook meat on fire; thus a process has begun that has led the space where these functions are carried out to becoming one of the most significant environments in the house. With the passing of time and changing needs, the kitchen has undergone substantial changes both in terms of its location and importance within the house, and for its furnishings and equipment.

Key words: Kitchen evolution, kitchen design, kitchen configurations.

1. Introduction

This paper starts from a research on the evolution of the kitchen environment carried out some years ago. I thought it was useful to continue the research since the way of life has radically changed in recent years and at the same time, the adopted technologies have undergone great changes.

The kitchen environment has always been the place where food is prepared and preserved. Like the bathroom, it has required special technological equipments, specific tools and furnishings, essential to the performance of its functions that have undergone considerable development over the years.

In the 18th century, the potager appears, a brickwork cooker with a variable number of hotplates, which makes it possible to manage cooking by regulating the intensity of the fires and the simultaneous preparation of several foods. Later, in America, cast iron stoves and burners are made, while in Europe, the tiled cooking bench is preferred to other systems because it guarantees a more uniform heat. Around 1850, the old wood burning stoves disappear and are replaced by gas cookers, made of cast iron with advantages both in terms of cooking food, dimension, ignition and cleaning. The diffusion of the refrigerator represents a

further advance as an evolution of the icebox.

2. Women's Contribution in America (1840~1920)

In the second half of the 19th century, the first feminist movements affirmed the social value of cooking. In the United States, and especially in the new western territories, women are considered a symbol of civilization and codification of domestic life. In America, Catherine Beecher develops her ideas, defining the work done within the walls of the house as a real profession. In 1841, she publishes *A Treatise on Domestic Economy* for female schools, which set out all the themes concerning the way in which modern women have to deal with their tasks: cooking, ironing, washing, cleaning, furnishing the rooms, and caring for the garden.

In 1869, with the collaboration of her sister, she writes a revolutionary text for the time, which had a very wide circulation "The American Woman's Home: or Principles of Domestic Science" [1]. In this essay, she claims dignity and scientificity to house work. She maintains that the kitchen's structure has to change and aims, first of all, at a rational use of space and at the creation of modern equipment (Fig. 1). She is inspired by the Mississippi steamboat's kitchen where the cook, despite the small space, can prepare meals for up to two hundred people.

Corresponding author: Simona Canepa, assistant professor; research field: interiors and exhibit. E-mail: simona.canepa@polito.it.

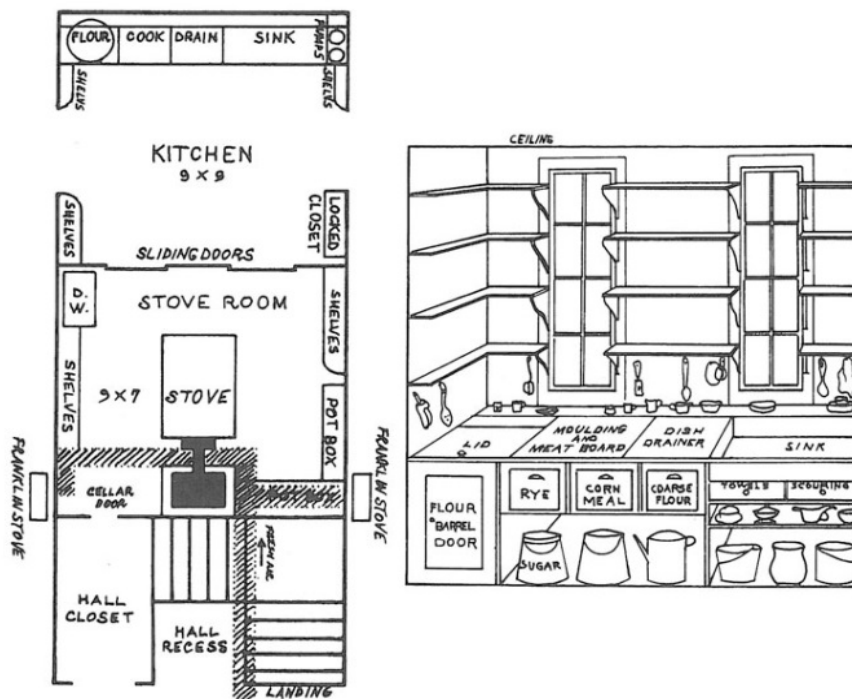

Fig. 1 Plan and view of the kitchen proposed by C. Beecher.

Under the motto “everything in its place”, Catherine Beecher reorganizes all the spaces in the kitchen:

- eliminates the traditional table in the centre of the room and insulated sideboard;
- offers minimal and continuous worktops, either placed close together or underneath windows for optimum illumination;
- unifies the height of the worktops and puts underneath low furniture;
- creates, next to the sink, the dish drainer that can be tipped, like a lid, by means of special hinges;
- places on the top continuous shelving units for tableware and utensils;
- separates cast iron coal stoves from the washing block;
- divides the kitchen area from the dining area by means of sliding glass doors.

Christine Frederick in 1913 wrote the essay “The New Housekeeping: Efficiency Studies in Home Management” [2]: she takes over Beecher’s ideas, updates and modifies them, inspired by Taylorist theories for profits maximization. Translating these principles from the industrial assembly line into

everyday living, Christine Frederick theorizes an image of cooking characterized by:

- elimination of irrational paths, of sources of time and energy waste;
- a layout of the furniture designed in such a way as to avoid unnecessary movements;
- central table lighting;
- oil-fired or spirit portable cookers, eliminating traditional coal-fired stoves that disperse heat;
- light colours and lots of light, obtained thanks to large windows facing south-east, possibly facing gardens or courtyards well ventilated (to brighten the housewife’s work);
- furnitures and worktops with washable surfaces without edges for easy cleaning.

She divides the complex work that takes place in this room into two main groups: the preparations for lunch and governance, graphically experimenting the optimal paths in a space structured according to her criteria and then compares them with those of a kitchen arranged in a traditional way. The study shows that it is the dining room’s door that represents the focal point of the routes (Fig. 2).

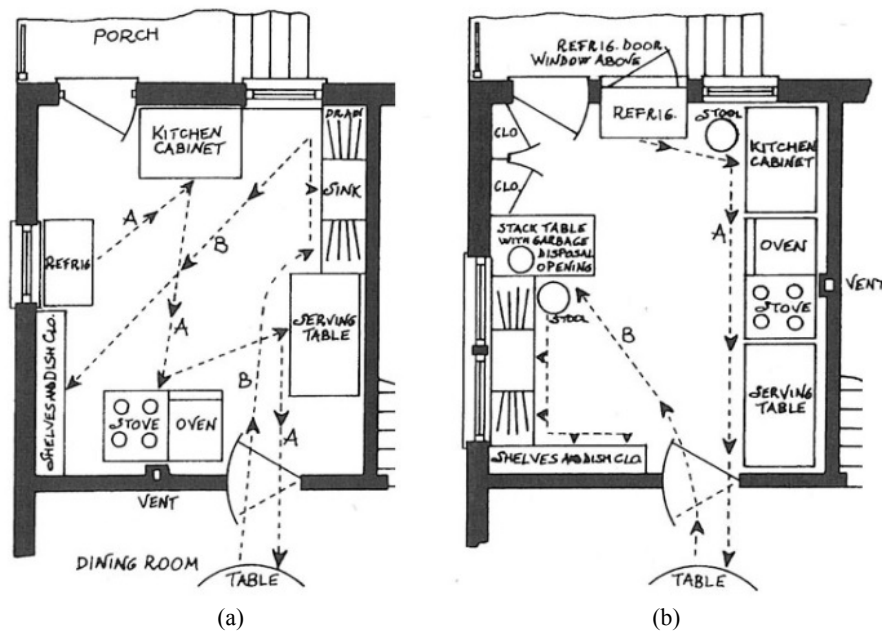

Fig. 2 Comparison between routes: (a) in a traditional kitchen; and (b) in a rational kitchen by C.Frederick.

The layout avoids unnecessary movements: the “preparation” thus occupies one side of the kitchen (from the refrigerator to the worktop to the table) while the “clearing” occupies the opposite side (from the table to the waste bin to the sink). Frederick is also trying to convince the first manufacturers of household appliances to rationalize and standardize their products. The first industrialized production of gas cookers, refrigerators and sinks was born in America between 1910 and 1930.

3. The Women’s Contribution in Europe (1920-1940)

In Europe, the theme of the kitchen becomes the focus of attention for many designers of the modern movement, who recognize in the kitchen model of the restaurant wagon designed by George M. Pullman, the concept of “space and technology” that they wanted to reproduce in modern homes with the need for healthy environments. They study small, rational and economical kitchen environments in order to aim at the less well-off classes. These include the studies carried out by the Bauhaus of Weimar for the model housing model “Das Haus am Horn” of 1923, the “cubex

kitchen” by the Belgian architect Herman de Koninck produced continuously from 1924 to 1958, the “wardrobe kitchen” by El Lissitzky proposed in 1928 by the “Construction Committee of the Soviet Socialist Republics”, the “kitchen in the niche” inside the common living room, screened with curtains or bellows doors.

In the mid 1920s, the kitchen was at the heart of the design debate in Germany; here the commitment of the modern movement is expressed with the formula of the Existenzminimum, attentive to achieve high quality performance in minimal spaces based both on the rational organization of spaces and on the integration of building-furniture.

The second half of the 1920s saw a new character on the scene that was very important in the evolution of the design and image of the kitchen. This is the German architect Erna Meyer who, during a long and fruitful collaboration with the Dutch architect Oud, transposes American ideologies into the European context. In 1926, Meyer publishes the book *The New Government of the House, a Manual That Teaches the Scientific Management of the House*, which will become a cornerstone for the diffusion of domestic life practices.

This manual represents the critical evolution of Christine Frederick's text: in addition to illustrating the innovations of Taylorism in house management, it highlights how many domestic problems can be solved by careful housing design. Unlike Frederick, she is convinced that the use of expensive and mechanised equipment to standardise household activities is not so necessary: it is enough to improve the working method through organisational control. Concerned to solve the priority problems of the European housewife, Meyer theorizes the need to have:

- continuous worktops at the right heights (to save time and energy);
- reduced spaces not to waste energy with unnecessary movements;
- good sources of natural and artificial light compared to the worktops.

In 1927, Oud used Erna Meyer's advice to design the kitchens of the five terraced houses in the Weissenhof district as part of the Die Wohnung International Exhibition in Stuttgart (Fig. 3a).

The kitchen is directly connected to the dining-living room through a passer-by door. In it appears for the first time the "L" shaped kitchen, with a long worktop on one side and on the other side a sink and a stove. This is a real innovation; the typologies used so far in fact provide for the occupation of all four sides of the room, with related problems of paths and movements. The height of all the kitchen tops is unique so as to create a real continuum. The wall to which the top with sink and stove is placed is equipped with two shelves (one for the pots and one for various containers), while above the stove, there is a small support for inserting the lids of the pans. The following inventions are from Erna Meyer:

- discharge for dirty water;
- the three gas stove fires (two for cooking and one for laundry pot);
- the wardrobe ventilated from the outside under the window, for food storage [3].

In the same year, Erna Meyer designed the prototype of the Munchener kitchen (Fig. 3b) open onto the dining room with stained-glass windows, as an alternative to the Frankfurter kitchen designed by Grete Schütte-Lihotzky.

Schütte-Lihotzky supports the idea that modern kitchen should be like a "small pharmaceutical laboratory" where order and cleanliness reign supreme. She develops her ideas between 1925 and 1930 when Ernst May (German architect responsible for the urban plan of Frankfurt am Main) entrusts her with the Department of Construction and Urban Planning:

- the main features of this kitchen are (Fig. 4): smooth and easily cleanable surfaces;

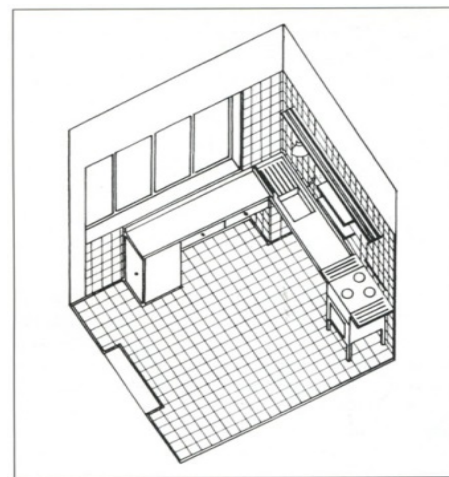

(a)

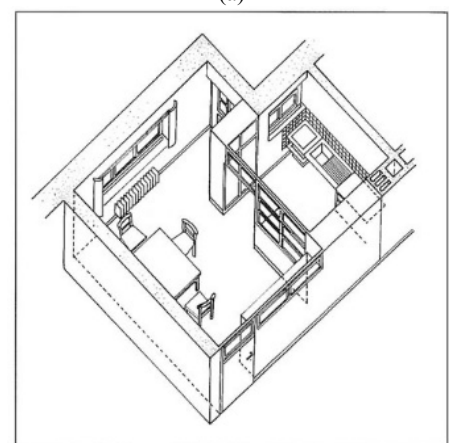

(b)

Fig. 3 Kitchens designed by E. Meyer: Oud's houses kitchen in: (a) Weissenhof exhibiton; and (b) Munchener kitchen.

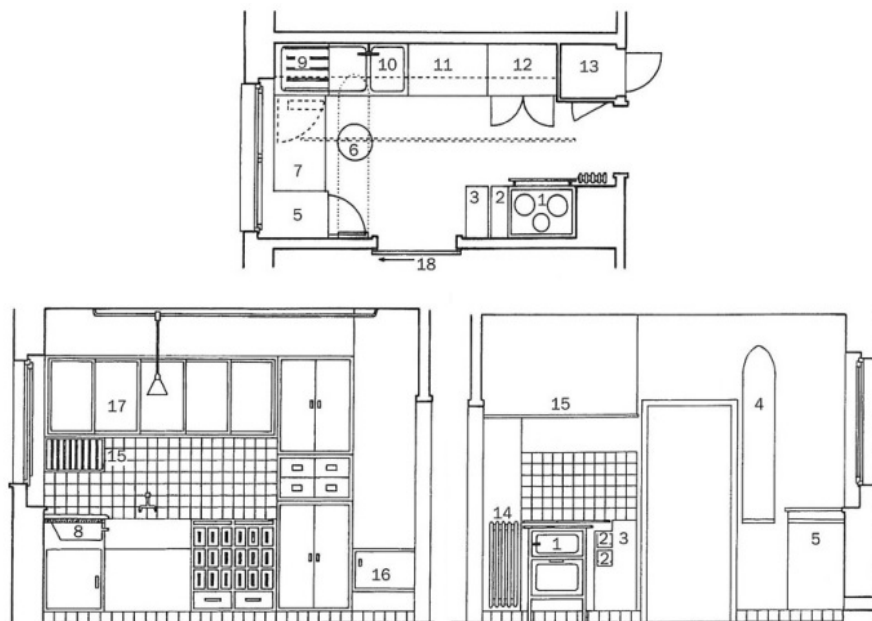

Fig. 4 Plan and views of Frankfurt kitchen by G. Schütte-Lihotzky.

- the use of materials such as aluminium, nickel-plated and enamelled metals, ceramic tiles, linoleum and xylolite (a kind of artificial wood);

- the “U” shape (with dimensions of only 3.44×1.87 m, equal to less than 7 m^2), where the rationalization of the spaces dedicated to the different activities and the work tools are integrated in a refined puzzle of great functionality;

- the height of the worktops, coded in 80 cm, based on ergonomic studies and the average height of women;

- separation of the kitchen from the dining area by means of a sliding door;

- the window that illuminates the room, designed in such a way that objects placed above the window sill do not impede its opening;

- an enamelled metal cabinet, placed under the window and ventilated from the outside so as to prefigure a refrigerator replacement (household appliance still little known in Europe and prohibitively expensive in an inexpensive kitchen);

- the wooden sink, with two zinc-coated basins, supplied by two taps, one for cold and one for hot water,

- the aluminium coated wooden drainer, placed

next to the sink;

- above it, there is a flat beech wall unit next to which there are others for crockery;

- the gas cooker, flanked by a food warmer which, if necessary, is covered to support other pans;

- the ventilated pan cabinet with adjustable racks, both horizontally and vertically for maximum flexibility;

- the folding ironing board and the broom’s cabinet (this is accessible only from the outside, so as not to risk getting dust and dirt into the kitchen) located near the door [4].

Great attention is paid to the choice of materials (for example, two flour drawers are made of oak because the presence of tannin in that wood hinders the possible presence of worms), light and bright colours. The artificial lighting consists of a lamp placed in the centre of the ceiling above a longitudinal sliding rail and of a cone reflecting light throughout the room. Finally, in order to facilitate cleaning, the furniture is all placed on a 10 cm high concrete base covered with tiles.

After the installation of the Frankfurter kitchen in the Römerstadt district (1927/28), which confirms its success, they will be produced in thirty variants and in more than ten thousand units.

4. The Kitchen of the 1940s-1950s

While in Europe everything stops due to World War II, the evolution of the kitchen continues in the United States, where in the decade 1940-1950, the kitchen became a typical theme of industrial design, aiming both at the introduction of materials such as glass (used for sliding furniture doors and oven doors) and plastic, and at the standardization of the overall dimensions of household appliances with a specific attention to integrated equipment. The so-called assembled kitchen was born, promoted mainly by the manufacturers of furniture and household appliances, often in relation to the contemporary movement of streamlining, i.e., the assimilation in design of aerodynamic shapes; this trend favours the curved lines of kitchen elements, created in homage to the car's body, which allow faster cleaning of surfaces. The need for an environment that allows greater flexibility and freedom of movement leads to the rejection of the isolated dining room and the affirmation of the open plan, with the kitchen no longer considered as a unit in its own right but subordinated to the entire living area and to the changes taking place at a hygienic, economic, organizational and functional level; kitchen and laundry become the pivotal element of the plant. A testament to this trend is the living kitchen, the kitchen-living room designed in 1945 by Raymond Fordyce, which aims to transform the kitchen into the dynamic centre of family activities where children play, housework and guest entertainment all revolve around the same environment [3]. Thanks also to a wise advertising campaign, the "American or American kitchen" becomes a true status symbol and a costume phenomenon.

General Motors takes a decisive step in the standardization of dimensions, reducing to only 60 cm the length and depth of the refrigerator (to allow it to be fitted with other furnishings) and develops a project for the dimension standardization for all other household appliances.

In 1962, chef Julia Child converted her kitchen in Cambridge, Massachusetts, into a television studio for

the first time: the program portrayed the country's transformation while she was cooking. Thanks to her program, Julia helped changing the way Americans relate to food and she became a real icon. When Julia Child moved back to her home state of California in 2001, she donated the kitchen from her Cambridge home to the Smithsonian National Museum of American History in Washington, D.C. This exhibition featured the actual kitchen, including the cabinets, appliances, cookbooks, kitchen table, and hundreds of utensils and gadgets. The exhibition gave visitors a peek into the working kitchen of one of the world's best-known cooks, and explored how her influence as an author and host of several television series changed the way Americans cook¹.

In the second half of the 1950s, in Europe too, the kitchen became a symbol of the role of a living room, not only in industrial progress, but above all in the status achieved by a family group. However, the principles of standardization and mechanization of kitchen elements manifest themselves almost a decade later than in the United States.

In Sweden, designers and architects update the concepts of Frankfurter kitchen, and a common line is being formed in European production (Scandinavian countries, England, France) that oscillates between the innovations of German kitchen with clear and squared surfaces on the one hand and the image of a future environment that is projected into the living room. In the meantime, a phase of technical simplification is under way, of research into new materials and greater attention to detail, in order to achieve maximum standardization; plastic materials, linoleum, crystal, stainless steel and anodized aluminium are part of this evolutionary process, because they are considered, unlike classic materials, to be much more resistant.

5. The Italian Situation from Rationalism to the Post-WWII Period (1920-1950)

In the period between the two world wars, the new

¹ www.americanhistory.si.edu.

trends of living are inserted in a particular moment, in which the woman and the kitchen are at the centre of the propaganda of the fascist regime: the kitchen is presented as a “medieval space”, the only place of aggregation, warm and welcoming, sometimes also used to sleep. The first works of social housing in the thirties proposed the kitchen as a service and personal hygiene room in continuity with the bathroom, which overlooks the kitchen without an intermediate compartment (only after World War II, the two functions are separated). The kitchen is large in size and concentrates many operations; due to its informal character, it remains a place of relationship and service and can accommodate family members at all times of the day. The individual elements are arranged freely in close proximity to the walls. These characteristics indicate the difficulty of Italian culture in absorbing the rules of American efficiency and those of Central European rationalism. However, there are also some innovative proposals of Italian rationalism, the most famous of which is the “Cucina Elettrica” by Piero Bottoni. Inspired by German studies, it was exhibited during the fourth Triennial in 1930 as part of “La Casa Elettrica” designed by Figini and Pollini under the patronage of Edison. A highly innovative project,

guided by the desire for total electrification of domestic life. Around forty or so, household appliances distributed throughout the house replace service personnel and promise to increase the quality of life. The kitchen is conceived as a laboratory divided into three zones: the office, the kitchen itself and the sink area [5]. Although these are three separate areas, their reciprocal connection is guaranteed by a system of interconnecting furniture, each room is then placed in contact with the adjacent one, so as to avoid unnecessary displacement. The arrangement is designed on the basis of man’s movements in space, the food carrier, an important cylindrical corner piece of furniture, divides the kitchen/dining room and is the fulcrum of the entire space system. The furniture can host a rich buffet offered in the living room and, at the same time, assume the function of a cupboard on the kitchen side. The table with movable side shelves is positioned against the wall, so as to reduce the number of paths, and should only be used as a worktop. In the kitchen, there are the first washing machine (household appliance that will become widespread in Italy only after 1955) and a “14 accessories”, an appliance capable of blending, kneading, squeezing, crushing, etc., progenitor of the current multifunction robots (Fig. 5).



Fig. 5 Cucina Elettrica by P. Bottoni.

In Italy, although exhibitions are promoted, in particular, the Triennials, conferences and publications, there are no wide-ranging residential initiatives that, as in Germany, Austria and the Netherlands, allow direct experimentation for large sections of the society. In Italy, architects always take the upper-middle class as their reference point.

The developments of the modern modular kitchen, which is intended for modern use, date back to the end of the Second World War and characterize the years of the economic boom. In the 1950s, production in Italy follows the trend of research related to household appliances, and is therefore attentive to technological evolution, along with the trend of dimensional and typological unification, which instead concerned the furniture market.

Italian works are immediately distinguished from foreign examples by their originality: in the first edition of the Compasso d'Oro Award in 1954, Augusto Magnaghi's modular kitchen for the company Saffa—made up of galvanised and painted sheet metal modules produced in a wide range of colours with the possibility of different mounting on stainless aluminium alloy pedestals—is awarded for its “stylistic independence from the rampant American model as well as for the modern taste that characterizes it” [5].

Compared to foreign models, the Italian products of the early fifties abandon linoleum, safety glass, buxus and anticorodal—materials that the fascist regime had strongly promoted and propagated—to confirm the primacy of steel furnitures that become monocoque steel sheet in the structure and ant for worktops. At the same time, the designers focus on a strong interplay of colours, lights and on the use of local materials such as walnut wood, ash and olive trees—the result of traditional craftsmanship in the furniture sector. The use of steel is justified by the more stable behaviour compared to changes in temperature and humidity and by the more marked characteristics of durability, practicality and maintainability. The kitchens in enameled sheet metal also see the use, beside the white,

of many other colours, linked to different materials for the worktops, made of Formica, enameled and vitrified or entirely made of stainless steel. The choice of Formica prevails over the others due to the qualities of resistance, ease of use, malleability and the possibility of use in more than sixty different colours. Over time it must be noted that the Achilles heel of metal kitchens is corrosion; hence the choice, after an initial successful period, to opt for alternative solutions, such as chipboard wood panels covered with plastic laminates or wood veneer.

6. Assembled Kitchen in Italy: Industrialisation and Mini-kitchens (1960-1970)

The economic boom of the sixties in Italy, with the massive industrialization of products, led to the birth of many companies still today undisputed leader in the production of kitchens (Dada, Triade, Effeti, Salvarani, Scavolini, Schiffini, Snaidero, Varenna, etc.).

The success of the new models is accompanied by the strong expansion of the household appliances sector: in the sixties, Italy became the first producer in Europe, second only to the United States. As a result, it is necessary to design modular furniture systems capable of accommodating the appliances inside them and unify everything by means of a continuous worktop.

Boffi's T12 model, made of plastic laminate and exposed natural wood, won the silver medal in 1960 at the XII Triennale di Milano and met great public success, also due to the fact that household appliances such as oven, refrigerator and cooking hobs are inserted for the first time in a coordinated way between the kitchen furniture. The T12 is considered the archetype of Italian cuisine of the sixties and will remain in production until the mid-1970s [3].

With the Salone del Mobile in 1961, the production situation in the kitchen sector was definitively consolidated, also from the point of view of the design input, thanks to the increasingly frequent use of

designers, who plan in close correlation with the manufacturer of furniture and household appliances; the production evolution is constant, also linked to the fact that we move progressively from the workmanship in order to the cycles of production by programs. The modularity of the components and the standardization of the dimensions means that the product is composed of a system of panels (doors, sides, lids, bottom) and, with regard to the materials, continues the experimentation of innovative materials such as synthetic resins, polyester and stainless steel. The modular kitchens that come from industrialized methods cost less, are consequently accessible to all social classes, but also have an ever-increasing quality standard. The increase in sales therefore leads in a short time, during this decade, to the presentation of a wide range of proposals, both formal and stylistic while the kitchen environment changes connotation, disappears the concept of kitchen laboratory, separated from the rest of the house to become more and more an integral part of the living area in which you eat, stay, live [5]. Examples of this new connotation are Program E5 and Program E6 by Zanuso for Elam, which proposes a central kitchen-environment in the house and a simple system of modular containers, and the Unibloc series, designed by Makio Hasuike—proposed in 1962 but developed in 1968—for Ariston Merloni (Fig. 6).

Created to solve the problem of adapting kitchen furniture in different environments, it is the first Italian example of coordination between furniture and

equipment; household appliances are assembled under a continuous stainless steel top floor, in the spaces below the sink and burners, the electrical system is centralised and unified water loading and discharging.

Boffi's E15 kitchen, designed by Luigi Massoni in 1965, allows to customize the customer's choice through the selection of doors, available in various colours and interchangeable; the number 15 that calls out the model refers to the design module: it represents the dimension in centimetres of the base module, chosen as the most suitable both to avoid waste of materials and to contain objects of small dimensions; with step changes of 15 cm, the base module goes to the 30 cm, one (for plate, heating plate, stove), to the 45 cm (drawers) and to the 60 cm (baking plates, refrigerator, dishwasher, pot and sink). The depth also takes on standardized dimensions, such as 60 cm., to accommodate the built-in appliances, designed on the shape of the cabinet and in many cases protected on the front face by a modular door [4].

The proposals of the various companies also take into account the new rules of coordination and unification, which have been applied rapidly since 1969 by the main kitchen manufacturers in order to rationalise production processes and support competition at European level. The main results of standardisation are the new furniture dimensions which concern:

- the height of the bases from the ground 85-90 cm;

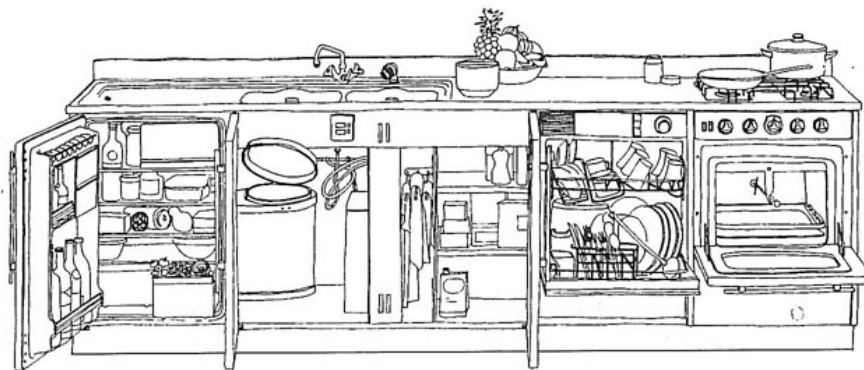

Fig. 6 Unibloc series by M. Hasuike for Ariston Merloni.

- the height of the skirting 10-15 cm;
- the height from the ground of the lower part of the wall unit 130 cm;
- the interspace between the base and wall unit 45-65 cm;
- the depth of the worktops 60 cm;
- and other dimensions that concern in more detail the kitchen furniture, including the width measurements of the various basic modules, wall units, sink and cabinet. At the same time, the standardization of the measurements of built-in appliances is confirmed, according to the European $60 \times 60 \times 85$ cm module, still in force today.

In 1973, Eurocucina made its debut in Italy, the first biennial exhibition of kitchen furniture, organized by COSMIT, the promotional committee of the Salone del Mobile, which intends to organize periodic comparisons between the building industry and furniture manufacturers.

After the period of experimentation on plastic materials, steel and crystal, in the seventies, we witness a return to wood considered a reassuring material that is offered both in the living rooms of the house and in the kitchens, in particular, light wood such as ash or walnut treated in the various finishes of visible grain or polished polyester lacquering.

The normalization process leads to a loss of originality between the various products; therefore, proposals are born aimed at counteracting the design uniformity increasingly widespread on the market; among the various solutions, the Minikitchen by Joe Colombo for Boffi,² a cube measuring $75 \times 75 \times 90$ cm, presented at the XIIIth Triennale in 1963 and winner of the gold medal, a monoblock in wood, stainless steel and plastic materials, which in only half a cubic meter contains all the essential functions of the kitchen environment: storage, washing, cooking, food storage (Fig. 7).

In 1968, the architect and designer Virgilio Forchiassin designed “Spazio Vivo” for Snaidero

(Fig. 8) [6].

It was an extraordinary and innovative product, able to interpret its customers’ new demands and to set out new lifestyle scenarios. The hob and sink were designed according to a revolutionary new concept: they were grouped into an island—for the first time ever! —and given the name “central block”. The remaining functions are assigned to the wall space using innovative moving blocks which, hinged to the base units, open and close according to the function, are designed to perform.

Joe Colombo again tackles the theme of kitchen space in his design of total spaces. During the exhibition *Visiona 69* in Cologne, he presents the Kitchen Box, a closable and air conditioned cabinet-block, equipped not only with the most technologically advanced equipment available on the market, but also with prototypes made of new materials (plastics and dralon fibers), as part of the exhibition in Italy. The new domestic landscape at the Moma in New York in 1972, proposes the Total Furnishing Unit: a monoblock independent from the housing container, able to guarantee manoeuvrability, flexibility and decomposition ability. The system consists of four parts: kitchen, cupboard, bathroom, bed & privacy. The wardrobe acts as a diaphragm between the kitchen and the bed & privacy environment that summarizes all the functions of living, eating, sleeping and reading (Fig. 9a).

Within the same exhibition in the environments section, Ettore Sottsass produced a series of interchangeable and moveable closets, moulded in grey plastic; inside these pieces of furniture are placed all the elements that are useful for living: the stove to cook on, the refrigerator to keep the food in, the cupboard for storing clothes, the shower, the place to sit and read, the jukebox to enjoy music, a bookcase for books. Each module is equipped with wheels: the idea is that the elements can be moved closer or farther away from oneself. These pieces of furniture can be either joined together with demountable hinges, or detached or

² www.boffi.com.



Fig. 7 Minikitchen by J. Colombo for Boffi.



Fig. 8 Spazio Vivo by V. Focchiassin for Snaidero.

connected with the electric power, water and air (Fig. 9b).

It is also worth mentioning the proposals of Zanuso and Sapper's mobile units of dwelling and Rosselli's residential capsule with a minimum, essential and technical kitchen, particularly suitable for dwellings for temporary and emergency situations [6].

From these examples, the idea is that kitchens are no longer lived spaces; processed foods are no longer prepared here and leave the space to those that require

rapid preparation (different dehydrated, frozen or canned products spread rapidly). In everyday life among the younger generations, eating in the kitchen or dining room seems to be no longer meaningful: kitchens promote the counter-snack surrounded by high stools for quick meals when you are at home.

7. Kitchens from the 1980s to the Present Day

The kitchen environment of the eighties is proposed again as a multifunctional environment, open and

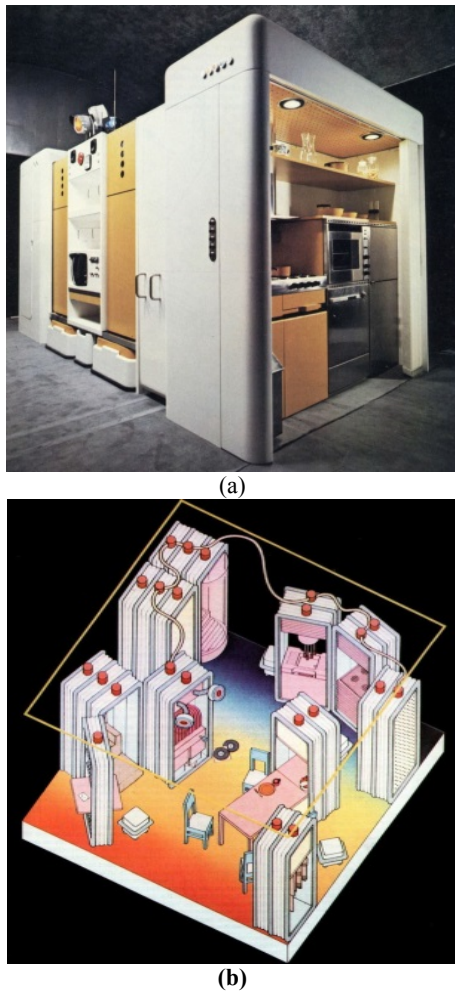

Fig. 9 Total furnishing unit by: (a) J. Colombo; and Fiberglass furniture by (b) E. Sottsass.

connected to the other rooms of the house, where you can stay with your friends, entertain yourself in free moments, thus transforming it from an isolated functional laboratory to a multifunctional space. There is a search for valuable and expensive materials: wood of rare and imported species, steels, glossy lacquers, chrome plating. The eighties are the exaltation of the desire to always appear different, of buying disposable products.

La Snaidero, which, in the 1980s, was one of the most important Italian companies in the production of modular kitchen furniture, in 1982 proposed the Abaco line, designed by Giovanni Offredi and Angelo Mangiarotti for a demanding and refined clientele characterized by the use of natural stones, lacquered surfaces and fully concealed appliances.

On the technological and professional front, the reference is the German Bulthaup, which in 1988 proposed the KWB (kitchen workbench) workstation:³ a single light metal bench of 261×74 cm designed for the insertion of a cooker hob, sink and worktop for food preparation. The workbench brought design elements typical of professional kitchens into the private setting, and went on to win multiple awards (Fig. 10).

In these years, a part of the kitchen furniture began to detach itself from the walls, creating new distribution solutions such as the peninsula and the island equipped with a cooker hob with an extractor hood placed at the centre of the room's ceiling. The wall units are replaced by functional units of shelves and accessories with chrome-plated metal rods. Other solutions, abandoning the base-wall unit system, develop the concept of kitchen-cabinet design: full-height cabinets replace the traditional bases and wall units, bringing larger capacity for a smaller space size.

In the 1990s, the kitchens proposed to the public during the trade shows are minimal and functional, distinguished by simplicity and stylistic cleanness, combining steel with precious materials such as wenge wood and marble, together with new materials that reproduce the aesthetical characteristics of natural materials but with higher performance and greater resistance and easier maintenance. In these years, the first ergonomics studies were developed. Many companies begin to make models with depths higher than the canonical 60 cm, reaching a size of 75 or 80 cm. Gabriele Centazzo proposes for Valcucine an equipped 20 cm wide cavity, inside which a space is available for hydraulic and electrical connections, giving the designer the freedom to place the sink and the cooker hob free from the positions set for the water and gas outlet.⁴ The canal is also equipped with a series of containers designed for precise functions: compartments for electrical sockets and gas valve,

³ www.bulthaup.com.

⁴ www.valcucine.com.



Fig. 10 KWB workstation by Bulthaup.

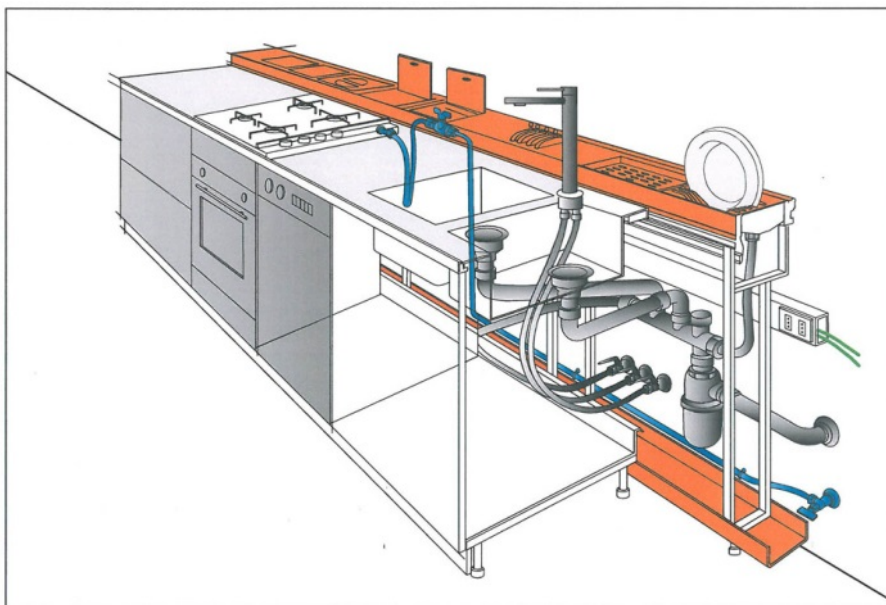

Fig. 11 The equipped element of Valcucine.

shelves for knives and chopping boards, food and detergent trays, dish and glass drainer. In this way, the work surface is enlarged by moving the operating space away from the wall units (Figs. 11 and 12).

The width of the modules also acquires the new size of 40 cm (with its multiples of 80 and 120 cm). If this size generally serves to extend the modularity of the compositions, the 80 cm size is used in some cases to house some of the non-standard appliances (such as

ovens and cooking plates), while the 120 cm size is generally used for large pull-out baskets, to accommodate pans and bulky objects. Ergonomic studies also concern the opening of the wall units, the column oven, the presence of food storage columns and corner bases.

Most manufacturers are committed to the use of environmentally friendly, recyclable and long-lasting materials and start researching production processes

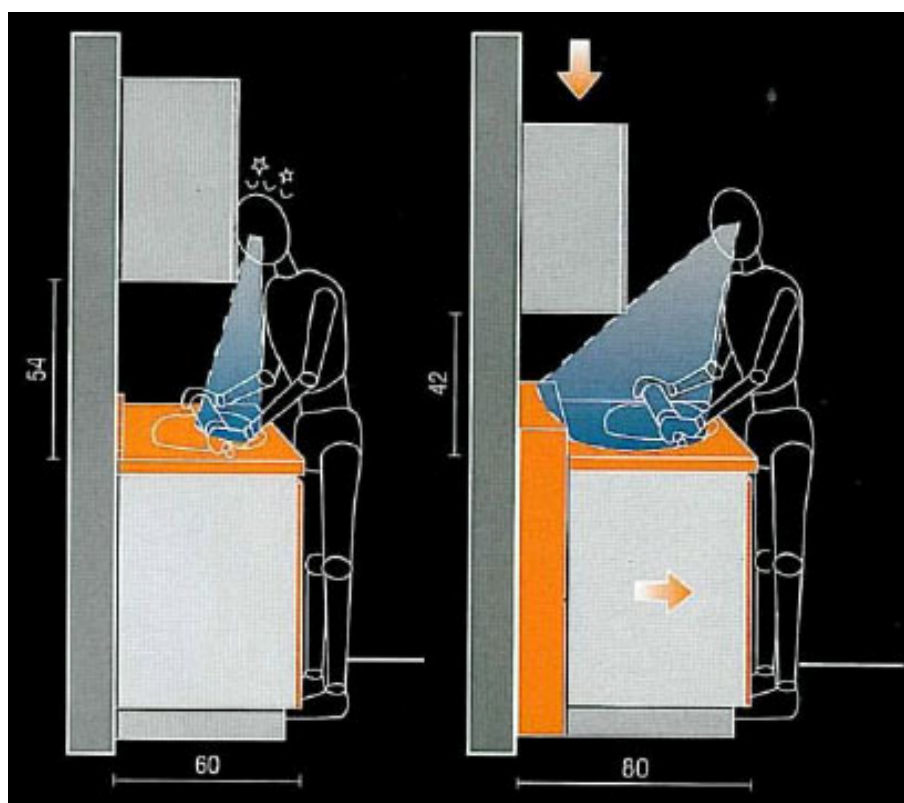

Fig. 12 Ergonomic study by Valcucine.

that allow a lower environmental impact with the minimization of the use of chemical products.

The first studies to reduce barriers and promote the autonomy of users in the kitchen date back to the turn of the millennium; the results of these researches are applied in numerous models, including SkyLab by Snaihero and Utility System by Scavolini,⁵ where the proposed elements system succeeds in transforming a kitchen into a space fully accessible to disabled, elderly or people with reduced possibilities of action and movement. The main features are the suspended and lowered worktop to allow easier use by eliminating the traditional bases and using drawer units on wheels, the contoured edges to allow more practical movements. The wall units, if present, are equipped with shelves that can be lowered electrically. Household appliances are specifically designed, such as ovens with shutter-like opening (Fig. 13).

The latest editions of Euro Cucina have presented to

⁵ www.scavolini.com.

the public a kitchen open to the living room and other areas of the house, free of visual barriers, consisting of simple volumes, for the majority rectilinear, which articulate the environment and make up islands and peninsulas with large snack tops. The materials used are not only of great quality, but also able to communicate very effectively with visitors through the tactile and visual experience. Kitchen containers are increasingly equipped, so the environment is getting tidier, or at least invites you to put in order since each element can find its own precise location in the drawing of the container equipment (Fig. 14).

The cooker hob has a totally flat, smooth, glossy and generally black surface, because it does not work with gas but with current, it does not need stoves where to let out gas or cast iron plates to support the pots: the heat, in fact, is generated by an electromagnetic field that is released only in contact with the pot and only inside the diameter of the pot. The extractor hoods have also evolved both from a technological point of view

and, above all, from an aesthetic point of view (Fig. 15).

The extractor hoods are integrated in the kitchen worktop below the cooker hob, and are practically

invisible until they are used. In addition, the hoods feature LED (light-emitting diode) lighting that uniformly illuminates the worktop when activated



Fig. 13 Utility system by Scavolini.



Fig. 14 Example of drawer organization (Valcucine).



Fig. 15 Example of extractor new generation (Franke).

Started in 2008, the collaboration between the Dada Group and Armani has developed: design and comfort, elegance and functionality are the characteristics that characterize the kitchens, the result of the collaboration with the fashion world of Giorgio Armani.⁶ The kitchen is interpreted as a workspace capable of conveying emotions and an atmosphere, just like the living or sleeping area. A large white marble top slides and reveals the working surface of the steel kitchen, the covering of the island and of the wall system feature a cladding in sassafras wooden slats rhythmized by horizontal metal profiles carved into the wood. The wall is a boiserie with full height columns and backward wall units with electric horizontal sliding doors that free the tops from any encumbrance. A patented vertical sliding mechanism allows the oven to hide behind the sash and become visible only when used (Fig. 16).

Zaha Hadid has conceived the kitchen Z. Island in collaboration with Ernestomeda and DuPont Corian[®] as a fluid environment consisting of two islands: the one dedicated to the fire (with cooker hob and heating plate) is elongated and curves on the right margin, the one dedicated to water (with sink, drying area and integrated dishwasher, fully retractable) is hexagonal and compact (Fig. 17).

Jean Nouvel has designed for Ernestomeda the Nouvel Lumieres prototype: the wardrobe and wall units doors are Corian[®] panels with high translucency, supported on the perimeter by a plexiglas frame, the backlit backrests give extraordinary effects of Chinese shadows with the shapes of the tools contained (Fig. 18).⁷

Boffi, a year after Zaha Hadid's death, has put into production the cove kitchen island in DuPont Corian[®] black and white that the Iranian architect designed for the apartments of an exclusive residential building in New York: the kitchen with its sleek outlines, smooth edges, and curvilinear geometry, takes up the soft and dynamic lines of the façade of the building designed by

Zaha Hadid. In the Boffi catalogue, the kitchen is available in two sizes and a variety of materials including hand-finished natural stone, selected wood and high performing Corian, the kitchen can be wholly customized to the client's precise specification and requirements (Fig. 19).⁸

I like to remember some models of kitchens that were proposed in the last edition of Euro Cucina in 2016 in Milan. The Lago's Air Kitchen, winner of the 2016 Good Design Award Best Product/Kitchen Section, is a hymn to conviviality. Around it, the guests participate in the preparation of food both through the visual relationship with the cook and in close proximity to him. Born as a contemporary development of round kitchens, this design kitchen is characterized by a circular shape that transforms the island almost into a round table, which welcomes both chef and diners, thus becoming a social place, perfect for the birth of conversations and interactions. The round top in glossy glass, white or coloured, or in oak wood, with integrated induction hob, seems almost suspended from the ground thanks to the transparency of the tempered glass legs (Fig. 20).⁹

Aria is the result of Snaihero's collaboration with Design House Pininfarina, which has applied technologies from the nautical and automotive sectors to the kitchen. The inspiration for the new Aria kitchen comes from the observation of nature: the main structure, inspired by a wing profile, from the fast, dynamic line, aimed at the future. A body that originates in the lower part of the central core, then pushes upwards to accommodate the lower surface and the shelves. Finally, it develops parallel to the work surface to end in an eye of light, a true sun that illuminates and warms aria. The central structure is made of carbon fiber and, for this reason, is characterized by high mechanical strength while maintaining an excellent lightness. Light is the great protagonist of the Aria project: the lamp ring above the

⁶ www.armanidada.com.

⁷ www.ernestomeda.it.

⁸ www.boffi.com.

⁹ www.lago.it.



Fig. 16 Slide kitchen by Armani for Dada.

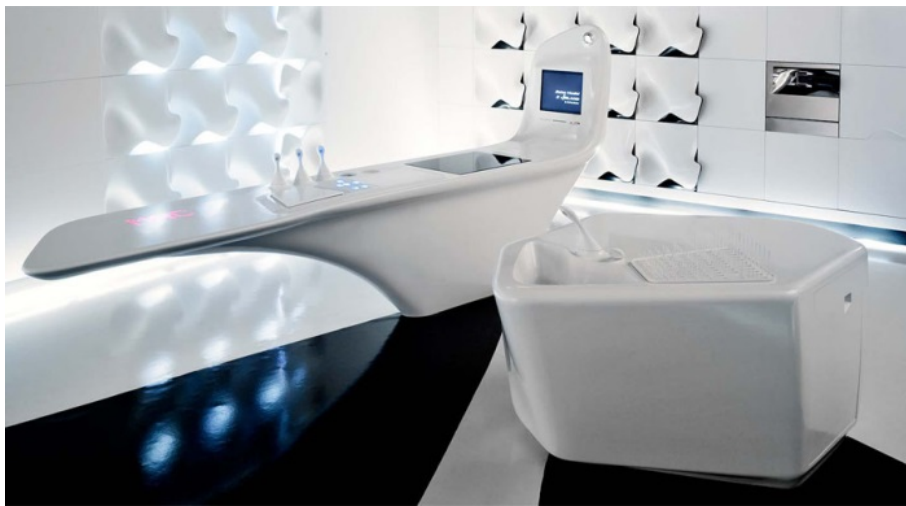

Fig. 17 Z. Island by Hadid for Ernestomeda.



Fig. 18 Nouvel Lumieres by Nouvel for Ernestomeda.



Fig. 19 Cove kitchen by Hadid for Boffi.



Fig. 20 Air kitchen by Lago.

operating area is made of polycarbonate and incorporates a low energy consumption LED lighting system, able to regulate both the intensity of light (operational light or simple atmosphere light) and its temperature (hot light or cold light) according to the operational requirements (Fig. 21).¹⁰

¹⁰ www.snaidero.it.

8. Design Proposals

The kitchen can be defined as a set of different and specific functions that must be coordinated with each other. The basic functions common to any kitchen correspond to three essential pieces of equipment: the sink, hob and refrigerator.

The work triangle (Fig. 22) is a model that addresses the problem of reciprocal spatial placement between



Fig. 21 Aria by Pininfarina for Snaidero.

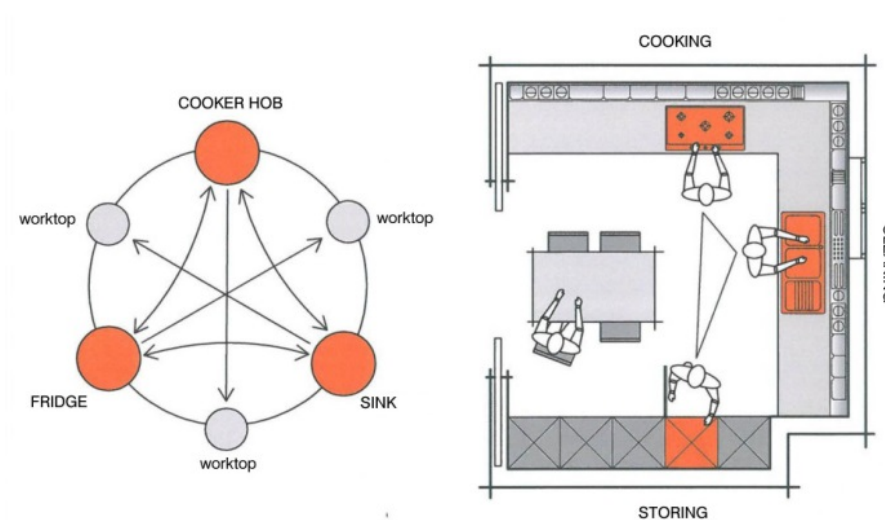

Fig. 22 Work triangle.

the three main pieces of equipment and is designed to maximize efficiency in the use of the kitchen by a single person on the basis of movement studies linked to Tayloristic principles for maximizing the performance at work.

The model was developed by the University of Illinois School of Architecture in the 1940s to emphasize the benefits of standardized production. It is still a model widely adopted in the design of household kitchens. It is important to take into account the movements necessary for the various operations in order to avoid wasting energy and movement to

optimise domestic work. The perimeter of the triangle, measured by placing the centre of each of the three elements as a vertex, must be between 3.6 and 6.6 m long. Lower lengths mean that the kitchen is too narrow and there is too little work space, while longer lengths mean too much distance to travel and make cooking slow and tiring.

From a planimetric point of view, depending on the dimensions available, you can have different configurations (Fig. 23):

- linear kitchen is the simplest configuration that can be realized, often it represents the required solution

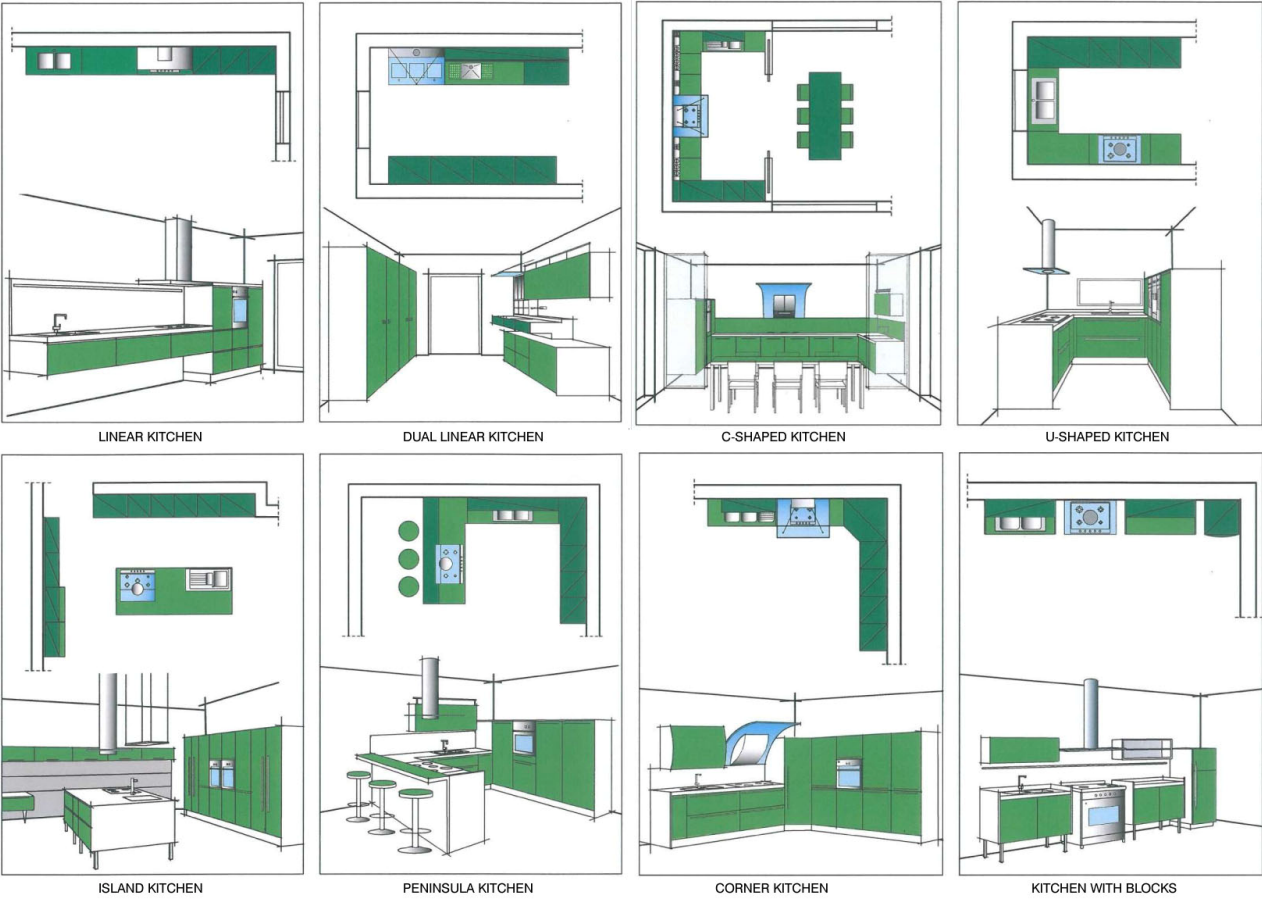

Fig. 23 Different configurations for a kitchen



Fig. 24 The kitchen in the penthouse of The Number 6 in Turin, Italy (the building won in 2015 the Building of the Year Award in the refurbishment category promoted by Arch Daily).

for small rooms (short and long rooms in most cases) or it can be the minimum equipment for a studio used also for living room and sleeping area: this typology allows to free a space that can be used for other uses. The limits consist of reduced storage space;

- double linear kitchen: the arrangement of the furniture along the two opposite walls traces a central corridor in which it is possible to work without almost moving, or do so with short steps. Many architects, manufacturers and cooks agree that the most effective solution is to place the refrigerator and sink on one side, with the cooking point centrally placed in relation to the latter two, but on the opposite side;

- C-shaped kitchen: optimizes the movements within the space bounded by the worktops. A solution with sliding doors excludes the working area from view and allows you to have a room exclusively for the dining area;

- U-shaped kitchen: allows you to obtain a large working area in a compact environment. The elements come arranged on three sides. Unlike the C-shaped kitchen, there is not enough space inside the U-shaped kitchen to fit the table;

- island cuisine: this type of arrangement comes from professional kitchens, for which the arrangement of equipment in the centre is widespread. The main advantage is the concentration of everything needed to cook around a single element that can be used on all four sides. The main limitation concerns the work on the hydraulic and electrical system necessary for installation. In addition, the room has to be quite large, as the island is usually combined with some storage units arranged along the walls;

- peninsula kitchen: this configuration is particularly suitable for open-plan kitchens. The peninsula is a comfortable additional unit that articulates the kitchen space, can act as an additional worktop, can accommodate sink and/or hob and can be equipped with a counter;

- corner kitchen: the elements occupy two adjacent sides of the kitchen. Washbasin, cooker hob,

refrigerator must be located quite close together, in order to reduce distances and make it easier to carry out the functions; the only drawback is the presence of a corner that is difficult to access in terms of storage;

- block kitchen: the compositional flexibility allows you to create a kitchen that, not being tied to a rigid design, can adapt to different configurations of the architectural space.

9. Conclusions

The recent changes in the way of life have given the kitchen an absolutely central role within the home, making it a complex space characterized by changing needs. The evolution of living models has seen the kitchen opening to the other common spaces and accommodating the most diverse activities. Moreover, contemporary lifestyles and rhythms influence culinary attitudes, which vary over the week or even the day, with the alternation of fast dishes and dishes that require more time and dedication. This scenario offers interesting ideas for a reinterpretation of the kitchen space and for the search for greater flexibility and adaptability in the use of its functions by all the people who share it. We are therefore witnessing a phenomenon whereby the kitchen, freed from the role of service room, like the bathroom, is assigned more and more spaces organized according to precise models (in corners, blocks, islands, peninsula), integrating it with other environments designed and organized for social life, such as the living room. The aim is therefore to create a kitchen-open space, a refined environment that shows worktops and equipment with rational lines and spacious and elegant spaces (Fig. 24).

References

- [1] Beecher, C. 1869. *The American Woman's Home: Or Principles of Domestic Science*. New York: J.B. Ford and Company. Accessed January 1, 2018. <https://archive.org/details/americanwomansho00beecrich>.
- [2] Frederick. C. 1914. *The New Housekeeping: Efficiency Studies in Home Management*. New York: Doubleday, Page & Company. Accessed January 1, 2018. <https://archive.org/details/newhousekeeping00fredrich>.

- [3] Vivanti, L. 1999. "Evoluzione Della Cucina (Kitchen Evolution)." In *Ristrutturazione e Progettazione Degli Interni (Interior Refurbishment and Design)*, edited by Vaudetti, M., and Bricarello, G. Torino: Utet. (in Italian)
- [4] Vaudetti, M., and Canepa, S. 2010. *Architettura Degli Interni e Progetto Dell'Abitazione (Interior Architecture and House Project)*. Torino: Utet Scienze e Tecniche. (in Italian)
- [5] Romanelli, M., Laudani, M., and Vercelloni, L. 1990. *Gli Spazi del Cucinare (The Cooking Spaces)*. Milano: Electa. (in Italian)
- [6] Ambasz, E., ed. 1972. *Italy: The New Domestic Landscape*. New York: Graphic Society.



Journal of Civil Engineering and Architecture

Volume 11, Number 11, November 2017

David Publishing Company

616 Corporate Way, Suite 2-4876, Valley Cottage, NY 10989, USA

Tel: 1-323-984-7526, 323-410-1082; Fax: 1-323-984-7374, 323-908-0457

<http://www.davidpublisher.com>, www.davidpublisher.org

civil@davidpublishing.com, civil@davidpublishing.org, civil_davidpublishing@yahoo.com

ISSN 1934-7359



9 771934 735177