

The Effect of Sub-systems Design Parameters on Preliminary Aircraft Design in a Multidisciplinary Design Environment

Original

The Effect of Sub-systems Design Parameters on Preliminary Aircraft Design in a Multidisciplinary Design Environment / Fioriti, M., Boggero, L., Corpino, S., Prakasha, P.S., Ciampa, P.D., Nagel, B.. - In: TRANSPORTATION RESEARCH PROCEDIA. - ISSN 2352-1465. - STAMPA. - 29:(2018), pp. 135-145. [10.1016/j.trpro.2018.02.012]

Availability:

This version is available at: 11583/2701284 since: 2018-02-23T09:38:19Z

Publisher:

Elsevier

Published

DOI:10.1016/j.trpro.2018.02.012

Terms of use:

This article is made available under terms and conditions as specified in the corresponding bibliographic description in the repository

Publisher copyright

Elsevier postprint/Author's Accepted Manuscript

© 2018. This manuscript version is made available under the CC-BY-NC-ND 4.0 license
<http://creativecommons.org/licenses/by-nc-nd/4.0/>. The final authenticated version is available online at:
<http://dx.doi.org/10.1016/j.trpro.2018.02.012>

(Article begins on next page)

6th CEAS AIR & SPACE CONFERENCE AEROSPACE EUROPE 2017, CEAS 2017, 16-20
October 2017, Bucharest, Romania

The Effect of Sub-systems Design Parameters on Preliminary Aircraft Design in a Multidisciplinary Design Environment

Marco Fioriti^{a,*}, Luca Boggero^a, Sabrina Corpino^a,
Prajwal Shiva Prakasha^b, Pier Davide Ciampa^b, Björn Nagel^b

^a*Politecnico di Torino, C.so Duca degli Abruzzi n.24, 10129 Turin, Italy*

^b*German Aerospace Research Center (DLR), Blohmstraße 20, 21079 Hamburg, Germany*

Abstract

The remarkable complexity of the aircraft design is due to several reasons and one of these is certainly the high number of completely different design disciplines involved in the process. Many efforts are spent to harmonize and optimize the aircraft design trying to consider all disciplines together with the same level of detail. Within the ongoing H2020 AGILE research, an aircraft MDO (Multidisciplinary Design Optimization) process is setting up linking several design tools and, above all, competences together. This paper focuses on the evaluation of the effects of the main on-board systems design parameters on the other disciplines. Starting from a baseline aircraft (AGILE DC1 regional turbofan), the effect of each parameters have been quantified in terms of variation of aircraft weight, fuel consumption and engine performance. This analysis represents a useful starting point to better understand the importance and the influence of novel On-Board Systems configurations, such as More and All Electric, to the overall aircraft design.

© 2018 The Authors. Published by Elsevier B.V.

Peer-review under responsibility of the scientific committee of the 6th CEAS Air & Space Conference Aerospace Europe 2017.

Keywords: Multidisciplinary Design Optimization; Aircraft Sub-system Design; More Electric Aircraft; Design Space Parameters; Overall aircraft design.

* Corresponding author. Tel.: +39 011 090 6816.
E-mail address: marco.fioriti@polito.it

1. Introduction

The aircraft initial design is one of the most important phases of aircraft development since in a short time engineers have to frequently define a competitive and innovative product that should be considered nearly completed at the end of this phase. MDO (Multidisciplinary Design Optimization) techniques are essential to reduce the convergence time and to obtain an optimized design considering all main disciplines in a harmonized way. The final result should be a design more globally optimized than older projects in which a local optimization inside each technical specialty was pursued. The main difficulty in following this approach is to face the usual and unavoidable conflict between disciplines where the optimal solution in one specialty implies a lacking design for the others.

This paper is focused on OBS (On-Board Systems) design discipline considered in a multidisciplinary design environment set up to perform a civil aircraft preliminary design. The main aim is to quantify the effects of the main on-board system design results on overall aircraft. Design parameters, such as More and All Electric architectures could drive to different results, hence different influence on overall aircraft. The variation of these parameters determine a difference in terms of weight and power off-takes that is not negligible. Differences in terms of MTOM (maximum takeoff mass), fuel consumption, aerodynamic drag and engine thrust are only some of the effects on overall aircraft design. Knowing these effects, the process to select new OBS technologies is simplified. It is well known the strong impact of on-board systems on the overall aircraft. The three charts in Fig. 1 clearly show the influences in terms of mass, cost and maintenance actions of sub-systems compared with the entire airplane. According to Liscouët-Hanke(2008), aircraft on-board systems represent about the 30% of the aircraft empty weight and development, operation end direct maintenance costs. In support of this, Prof. Scholz(2009) stated that the percentage of sub-systems weight on the overall empty weight ranges from 23% (in case of modern long-range civil aircraft) up to 40%, considering smaller airplanes as business jets. Even the fuel consumption is affected by aircraft systems: a non-negligible part of the total power produced by the engines is supplied to on-board systems, hence influencing the quantity of fuel burnt during the flight, as about 5% of the total fuel is consumed for secondary power, as argued by Scholz (2002).

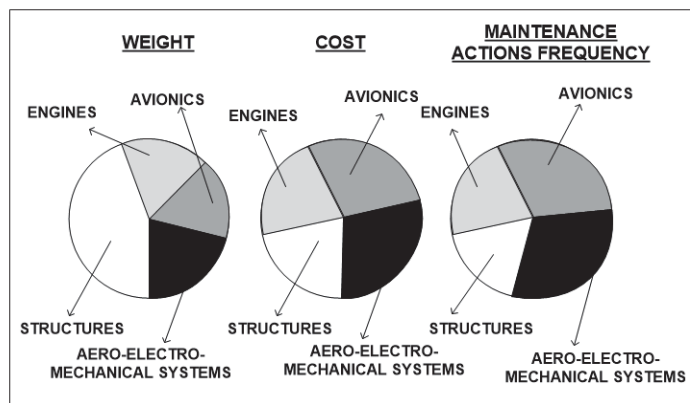

Fig. 1. Importance of aircraft on-board systems in the overall aircraft design.

Nomenclature

AEA	All Electric Aircraft
CPACS	Common Parametric Aircraft Configuration Scheme
FF	Fuel Flow, [%] in equations
FM	Fuel Mass, [%] in equations

HPGDS	Hydraulic Power Generation and Distribution System
MDA	Multidisciplinary Design Analysis
MDO	Multidisciplinary Design Optimization
MEA	More Electric Aircraft
MSYS	Systems Mass, [%] in equations
MTOM	Maximum Take-Off Mass, [%] in equations
OAD	Overall Aircraft Design
OBS	On-Board Systems
OEM	Operating Empty Mass
Pbleed	Bleed Air Offtakes, [%] in equations
Pofftakes	Shaft Power Offtakes, [%] in equations
RCE	Remote Component Environment
SFC	Engine Specific Fuel Consumption, [%] in equations
TLARs	Top Level Aircraft Requirements
TMAX	Maximum Thrust per Engine, [%] in equations
WS	Wing surface, [%] in equation

2. Overall aircraft design environment

In order to evaluate the effect of OBS design, it is necessary to set up an MDA (Multidisciplinary Design Analysis) workflow, which encompasses the main disciplines needed in OAD such as aerodynamics, structural design, propulsion design, OBS design, mission and performance calculations. ASTRID tool developed by Politecnico di Torino is used to calculate the influence of the systems design parameters on aircraft sub systems. ASTRID is able to design all main aircraft sub-systems from power generation and distribution (i.e. electric, pneumatic and hydraulic systems) to utilities systems (i.e. flight control, landing gear, environmental control, avionics, etc.). More details are provided in Chiesa et al. (2012). The effect of sub-systems redesign on aircraft overall design is then calculated using specific tools developed by DLR. The distributed process relies on multiple disciplinary analysis and design modules accessible via the framework. For the current study, a VLM aerodynamics module, based on the well-known AVL solver is chosen to calculate the aerodynamics characteristics. An in-house aeroelastic engine is selected for the loads calculation and a FEM based structural sizing of the main structural components. All the modules are integrated within a multi-fidelity synthesis process, deployed in RCE (Remote Component Environment)¹. DLR's RCE and Common Parametric Aircraft Configuration Scheme (CPACS)² are used, respectively, to establish an open and distributed MDO environment and to exchange the necessary design parameters using a common language. RCE runs the workflow exchanging inputs and outputs between various tools located among partner's network. With this research activity, the capabilities of Distributed Multi-fidelity optimization approach (Zill et al., 2012) and Multi-Disciplinary optimization approach (Ciampa et al., 2012) previously performed within DLR is expanded to additional disciplines such as Sub-systems synthesis capability via external tool ASTRID. The collaborative MDO framework is established such that more disciplinary tools can be added from new partners, broadening the optimization scope and fostering EU multi-institutional collaborations, as described by Prakasha et al. (2016a) and Prakasha et al. (2016b). To realize the airframe-system synergy evaluation in this study, the CPACS is used for interdisciplinary exchange of aircraft data between heterogeneous analysis codes. The CPACS data schema contains standard structure of information on the aircraft model such as geometry description, airframe design masses, performance requirements, aerodynamic polar, structural details, engine

¹<http://rcenvironment.de/>

²<http://cpacs.de>

parameters, mass properties, subsystem architecture details, and process data to control parts of a design process, which is necessary to initialize and trigger the disciplinary analysis modules.

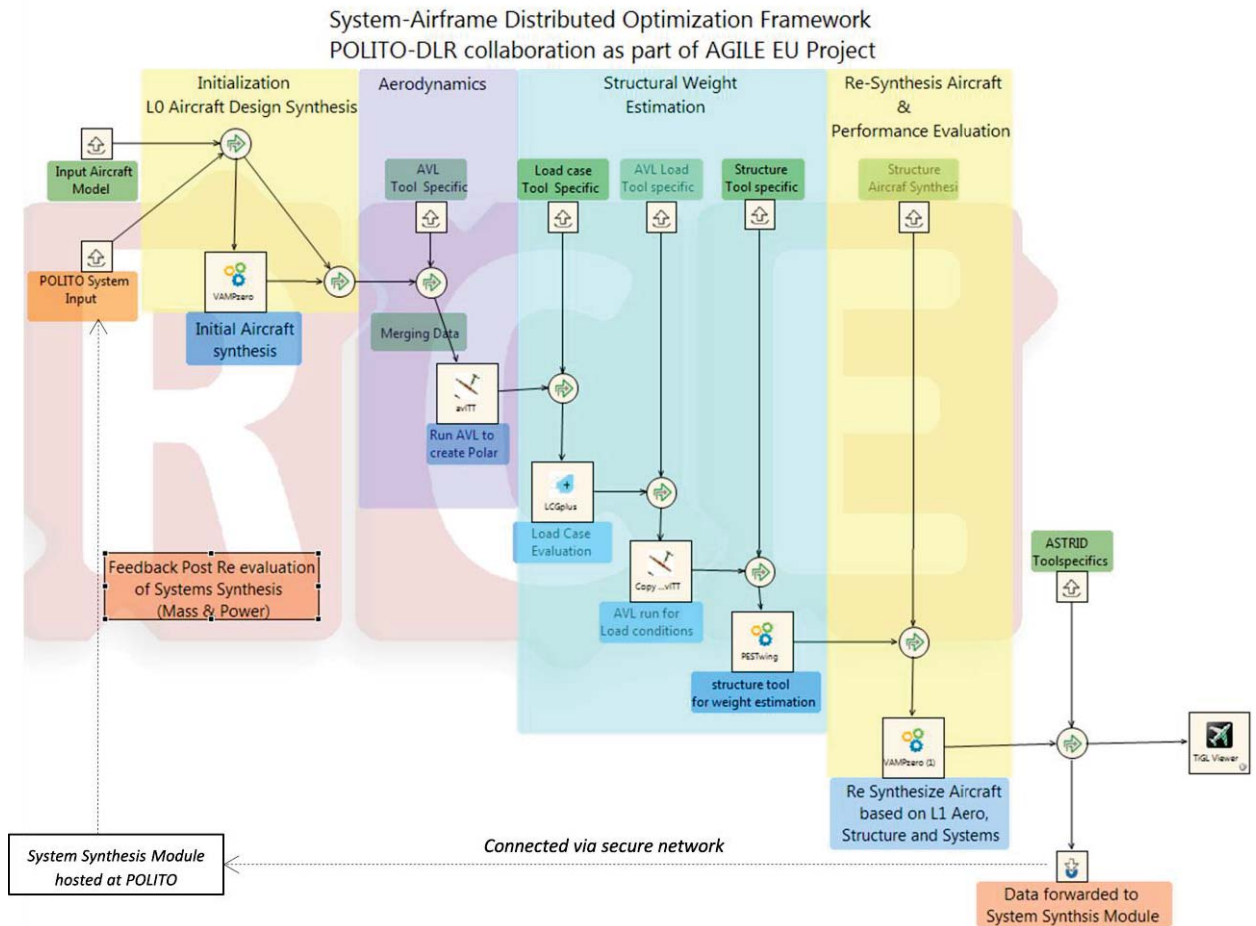

Fig. 2. Multidisciplinary design workflow in a distributed framework of tools

3. Effect of on-board systems parameters on overall aircraft design

After established a multidisciplinary design workflow including all main disciplines, it is possible to assess the effect of the on-board systems on the main aircraft parameters. The main OBSs parameters are the systems weight and the related power required from the propulsion system. The OBS volumes could influence the total aircraft drag. However, their effect can be considered secondary and it is neglected in this study. To quantify these effects on a civil aircraft, the AGILE DC1, a regional turbopfan carrying 90 passengers, is selected as reference (see Fig. 3 and Table 1).



Fig. 3. DC1 AGILE reference aircraft

Table 1. Main Top Level Aircraft Requirements (TLARs) of DC1 AGILE reference aircraft.

DC1 Aircraft TLARs	
Range [km]	3500
Design payload [kg]	9180
Max. payload [kg]	11500
Number of passengers	90
Cruise Mach [-]	0.78
TOFL @ ISA, SL [m]	1500
Wing Area [m ²]	84.3
Wing Span [m]	28.4
MTOM [kg]	45046
OEM [kg]	27421

In Table 2, the main systems parameters, their variations and the OAD parameters monitored during the design are summarized. The mass of the systems represents the main parameter considering its influence on the aircraft. It directly influences the aircraft weight and it has some effect on engine design. To analyse the effect on the OAD, a variation of maximum +/- 10% of the systems weight is imposed according to previous studies (Fioriti et al. 2017 and Prakasha et al. 2017) where different OBS architectures are compared. The actual systems mass for AGILE DC1 aircraft is about 8 tons. In Table 2, the systems mass does not include landing gear and furnishing masses that are considered constant changing OBS architectures. The secondary power required by OBS is the second main parameter that influences the whole aircraft. This power is used to supply the electric, hydraulic and pneumatic power generation and distribution systems. Usually, the secondary power is composed of mechanical power offtakes to drive the electric generators and hydraulic pumps and the bleed air from engine compressor. The bleed air is then used to supply the pneumatic system. The reference values listed in Table 2 are taken from previous studies – as Fioriti et al. (2017) – and they concern the conventional OBS architecture. Again, the range variation of these values considers the results of the same previous studies obtained analysing new OBS architectures such as different level of More Electric and All Electric. For these kind of configurations, the bleed air is usually reduced or totally removed (i.e. bleedless configuration) and consequently the necessary pneumatic power is produced electrically increasing the shaft power offtakes. Therefore, having the conventional configuration as reference, the power offtakes is gradually increased to the 200% and the bleed air is gradually decreased to 0%. In this way, all OBS architectures are covered, hence the possible value of their parameters.

Table 2. Main systems parameters and their variation considered during the analysis

On-board systems parameters	Reference value	Variation range	Expected results at OAD level
Systems Mass	3525 kg	-10% ÷ 10% (3173 kg ÷ 3878 kg)	MTOM, FM, OEM, SFC, FF, T_{max} , wing surface
Systems power off-takes	68.26 kW	0% ÷ 200% (68.26 kW ÷ 205 kW)	
Systems bleed air required	0.5239 kg/s	0% ÷ -100% (0.5239 kg/s ÷ 0 kg/s)	

For each value of the OBS parameters, an overall aircraft design is defined monitoring the main OAD parameters. Each design has been carried out considering the same aircraft TLARs (see Table 1). The Maximum Take-Off Mass (MTOM), the Fuel Mass (FM) and the Operating Empty Mass (OEM) are selected since they well describe the aircraft masses. Other parameters, such as engine Specific Fuel Consumption (SFC) and the required Fuel Flow (FF), are considered given the influence of power offtakes and bleed air on them. The wing surface and the maximum engine thrust represent other main aircraft specifications and they are monitored together with the other OAD parameters. In Fig. 4 are reported all influences of the OBS on OAD calculated by means of the tool workflow already presented in Fig. 2.

Figure 4 (a) and (b) both show the effect of system mass on aircraft MTOM, FM and OEM. The direct effect of an increase of system mass of 10% is the increase of aircraft OEM of about 3%. Indirectly, a greater OEM requires more thrust to the aircraft ($\approx 1.5\%$) and thus more fuel ($\approx 1.5\%$) to comply with the range requirement. The MTOM variation is closer to 2%. The effect on engine fuel flow has the same order of magnitude of the engine thrust and the engine SFC is nearly not affected. The wing surface is not reported in Figure 4 since its variation is always (for all analyses) in line with the MTOM one.

In Fig. 4 (c) and (d) the influence of the OBS power offtakes is shown. An increment of 200% of this parameter is compatible with the conversion from a conventional OBS architecture to a MEA one. In this case the direct effect on the fuel mass is notable ($\approx 1\%$) and this increment have an indirect effect on OEM and MTOM as expected. The OAD engine parameters are also influenced by power offtakes. With the same TLARs the engine thrust follows the increment in MTOM. However, the FF increment is notable ($\approx 1\%$) since it is given by two different drivers: the increment of engine thrust and the increment of engine SFC. According to Giannakakis et al. (2011), when a gas turbine engine have to drive additional mechanical load from the accessory gearbox, its SFC increases. Finally, in Fig. 4 (e) and (f) the effect of bleed air reduction is depicted. The reduction of 100% of bleed air is compatible with the use of the OBS bleedless configuration (i.e. MEA and AEA). The effect of the bleed air on engine SFC is greater compared with mechanical load (Giannakakis et al., 2011) and it is clearly shown in Fig. 4 (f) where the bleedless configuration reduces the SFC of about 1.2%. This entail a reduction of FF ($\approx 1.6\%$) and of engine thrust since the reduction of MTOM. It is worth noting the reduction of MTOM is only due to the reduction of the fuel required ($\approx 1.6\%$).

The following equations are defined through a linear regression of the data obtained during each aircraft design.

$$MTOM = 0.1934 \cdot M_{SYS} \quad (1)$$

$$OEM = 0.317 \cdot M_{SYS} \quad (2)$$

$$FM = 0.1583 \cdot M_{SYS} \quad (3)$$

$$T_{MAX} = 0.1612 \cdot M_{SYS} \quad (4)$$

$$FF = 0.1586 \cdot M_{SYS} \quad (5)$$

$$SFC = -0.0026 \cdot M_{SYS} \tag{6}$$

$$W_s = 0.1934 \cdot M_{SYS} \tag{7}$$

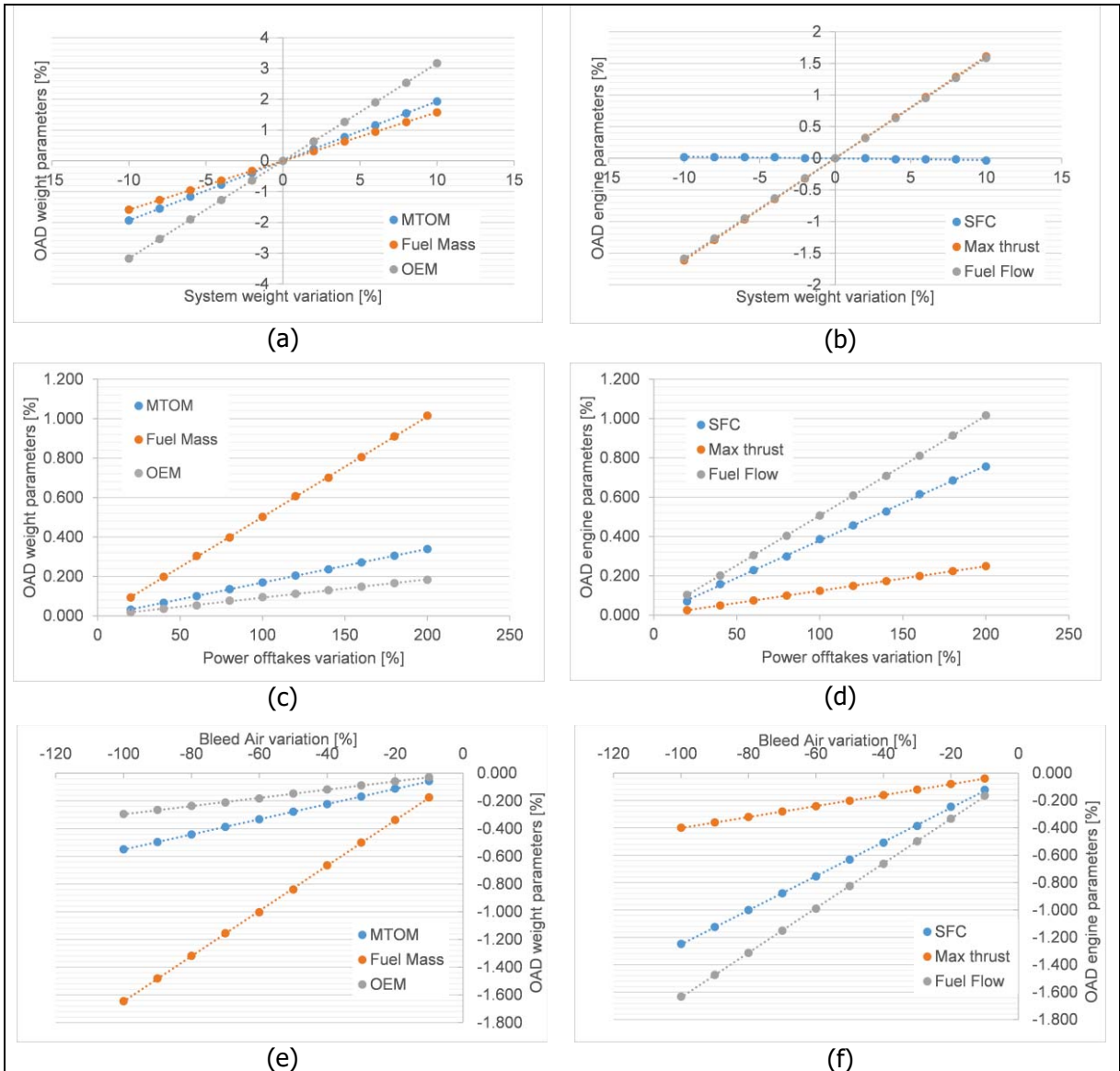

Fig. 4. Effect of OBS parameters on OAD.

The dependences of OAD parameters to systems weight are listed from Eq.1 to Eq.7. It is worth noting the same dependence of MTOM and wing surface. This is due by the same TLARs of each design that leads to the same wing loading. Therefore, to maintain constant the wing loading (i.e. the landing distance requirement) the wing surface is increased or decreased according to the MTOM variation by the workflow. Moreover, the Eq.6 shows the weak influence of systems weight, hence engine maximum thrust, on engine SFC. All other equations of this set show a

strong influence of MSYS on the OAD parameters. Therefore, all new OBS technologies useful in reducing the systems weight should have the priority during the design a new aircraft. These could include the use of higher hydraulic pressure as well as the introduction of high voltage (i.e. 270 VDC or 230 VAC) components that usually are lighter than the standard ones. In this way, also the removal of the hydraulic system could decrease the system weight.

$$MTOM = 0.0017 \cdot P_{offtakes} \quad (8)$$

$$OEM = 0.0009 \cdot P_{offtakes} \quad (9)$$

$$FM = 0.005 \cdot P_{offtakes} \quad (10)$$

$$T_{MAX} = 0.0012 \cdot P_{offtakes} \quad (11)$$

$$FF = 0.0051 \cdot P_{offtakes} \quad (12)$$

$$SFC = 0.0038 \cdot P_{offtakes} \quad (13)$$

$$W_S = 0.0017 \cdot P_{offtakes} \quad (14)$$

$$MTOM = 0.0055 \cdot P_{bleed} \quad (15)$$

$$OEM = 0.003 \cdot P_{bleed} \quad (16)$$

$$FM = 0.0165 \cdot P_{bleed} \quad (17)$$

$$T_{MAX} = 0.004 \cdot P_{bleed} \quad (18)$$

$$FF = 0.0164 \cdot P_{bleed} \quad (19)$$

$$SFC = 0.0125 \cdot P_{bleed} \quad (20)$$

$$W_S = 0.0055 \cdot P_{bleed} \quad (21)$$

From coefficients of Eqs. 10, 12 and 13, it is clear the strong relation between the shaft power offtakes and all parameters related with fuel consumption. With greater magnitude, the same happen in Eqs. 17, 19 and 20 which describe the influence of bleed air offtakes. From these last equations, it is clear the approach of new OBS technologies. Since the stronger influence of reducing the bleed air offtakes compared with the increase of shaft power offtakes, the pneumatic system electrification should lead to a not negligible fuel save, hence a lighter aircraft.

4. Model validation

The equations defined in Section 3 can be used within the on-board systems preliminary design in order to numerically predict some results at aircraft level, as masses, engine thrust and wing area. Furthermore, this class of prediction might be used in order to compare the impact of several system architectures on the OAD. In other words, given several on-board system configurations characterized by different technologies, equipment and design choices, it is possible to select the one that entails as instance a lower MTOM or a lower fuel consumption. Given the results of a certain OAD solution, as systems weight, MTOM and power off-takes, the equations can be applied to a different solution characterized by the same TLARs, but different on-board system architecture. Therefore, the main aircraft parameters can be obtained without running the entire workflow, hence saving efforts and computational time.

The following part of the current Section aims at validating the relations of Section 3, using as case study the AGILE DC1. Four kinds of on-board system architectures have been taken into account for this type of aircraft. All architectures are depicted in Fig. 5 and they are defined increasing the electrification degree (i.e. the amount of electric power generated compared to hydraulic and pneumatic ones).

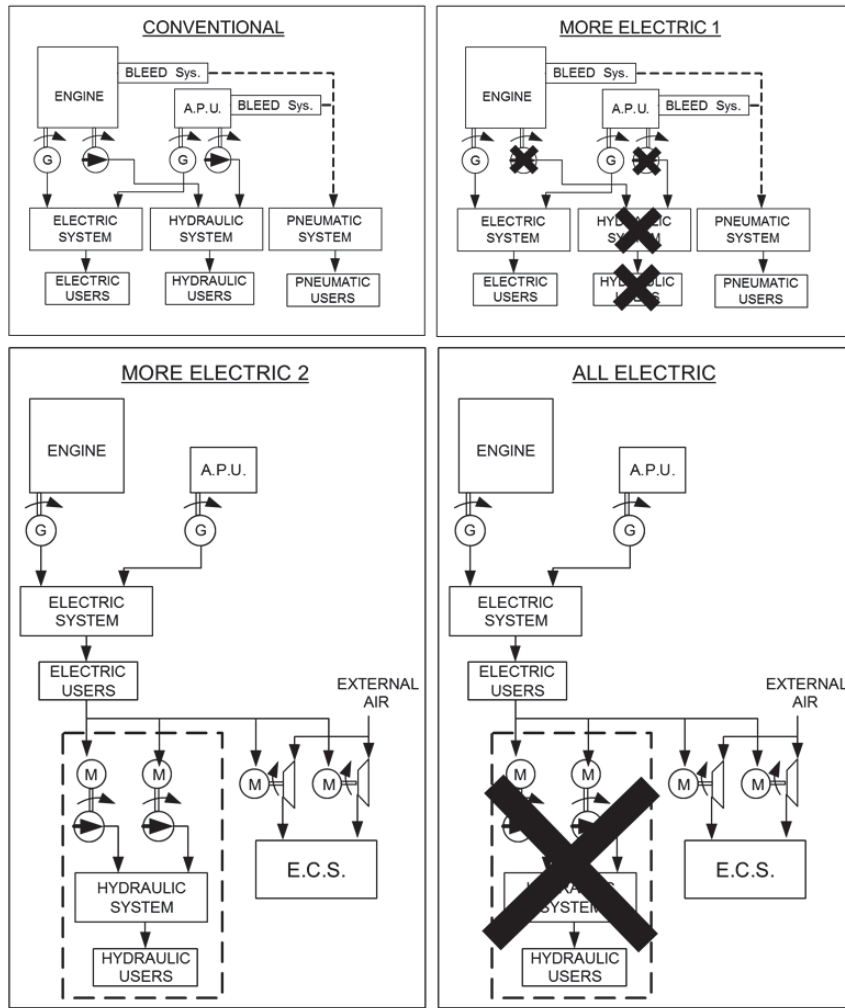

Fig. 5. Different OBS architectures for AGILE DC1 regional turboprop.

The first one is “Conventional”, as it is characterized by all the types of secondary power, i.e. pneumatic, hydraulic and electric. It is considered the state-of-the-art since most of the civil aircraft use this architecture. The second architecture is named “More Electric Aircraft 1 (MEA1)”. In this case, the Hydraulic Power Generation and Distribution System (HPGDS) is removed. Therefore, all the actuators and the landing gear brakes are electrically driven. Removing the pneumatic bleed system that takes air from the engine compressors, the “More Electric Aircraft 2 (MEA2)” architecture is derived from the “Conventional” one. In this case, the air conditioning and anti-ice systems are electric, but the engines operate at higher efficiency points, as stated by Cronin (1983), Jones (2002) and Rosero et al. (2007). Finally, removing all the types of energy except the electric one, the “All Electric Aircraft (AEA)” architecture is obtained.

Previously the OAD of the AGILE DC1 with the four on-board system architectures has been performed by Boggero et al. (2017). This design process is based on methodology proposed by Fioriti (2014). In Table 3 are

reported the results containing the main OBS parameters (i.e. MSYS, Pofftakes, Pbleed) for each architectures. Increasing the level of electrification the Pofftakes increases and Pbleed decreases. Conversely, MSYS is minimum for MEA1 since it is not linearly dependent with the electrification degree. In Table 4, some results at aircraft level (i.e. MTOM, W_s , T_{MAX}) estimated by means of the proposed relationships (grey rows) are listed together with the value previously calculated. It is worth noting the difference between the estimated and the calculated values is enough slight (always below 1%) to consider the equations in Section 3 validated.

Table 3. Main OBS parameters for different systems architectures.

OBS parameters	Conventional	MEA 1	MEA 2	AEA
M_{SYS} [kg]	3525	3289	3569	3441
Variation [%]	[-]	-6.70	1.25	-2.38
$P_{offtakes}$ [kW]	68.26	65.62	186.10	183.46
Variation [%]	[-]	-3.86	172.64	168.77
P_{bleed} [kg/s]	0.5239	0.5239	0	0
Variation [%]	[-]	0	-100	-100

Table 4. Comparison between estimated and calculated effect on OAD parameters.

OBS parameters	Conventional	MEA 1	MEA 2	AEA
MTOM (estimated) [kg]	[-]	36329	36484	36369
MTOM (calculated) [kg]	36540	36091	36469	36220
Difference [%]	[-]	-0.66	-0.04	-0.41
W_s (estimated) [m ²]	[-]	72.79	73.11	72.87
W_s (calculated) [m ²]	73.22	72.32	73.07	72.58
Difference [%]	[-]	-0.66	-0.04	-0.41
T_{MAX} per engine(estimated) [N]	[-]	81075	81380	81167
T_{MAX} per engine [N]	81466	80631	81370	80908
Difference [%]	[-]	-0.55	-0.01	-0.32

5. Conclusions

The influences of OBS on OAD main parameters are identified for a regional turbofan aircraft. The analysis shows a strong influence of the OBS mass and a lower, but not negligible, influence of the OBS power offtakes. Starting from these results, the main effort in enhancing the design of a regional aircraft should involve all new OBS technologies able to reduce the systems mass such as high voltage and high pressure generation and/or the removal of the hydraulic system. The equations obtained have been validated and they can be used to define the effect of modification of the OBS parameters having a global response that involve the whole aircraft. In this way, it is possible to minimize the time spent for running the entire workflow choosing at once the best OBS architecture. This kind of study was only possible by using a multidisciplinary design environment able to connect different tools

of different disciplines. Moreover, the automation of the presented workflow was another key factor to carry out this kind of analysis that requires a huge amount of calculation.

In future, starting from this basis, the analysis will be extended to other class of aircraft including long range liner, unmanned aerial vehicle and military aircraft. Moreover, the effect of the volume of OBS will be assessed together with the parameters already considered in the present study.

Acknowledgements

This work is carried out within AGILE H2020 European research project³ of which, one of the main purposes is the employment of MDO techniques to enhance the project competitiveness of standard and innovative aircraft configurations.

References

- Boggero, L., Fioriti, M., Corpino, S., & Ciampa, P. D., 2017. On-Board Systems Preliminary Sizing in an Overall Aircraft Design Environment. 17th AIAA Aviation Technology, Integration, and Operations Conference, AIAA AVIATION Forum. Denver, CO.
- Chiesa, S., Di Meo, G. A., Fioriti, M., Medici, G., & Viola, N., 2012. ASTRID - Aircraft On Board Systems Sizing and Trade-Off Analysis in Initial Design. REAS. Brno (CZ).
- Ciampa, P. D., Zill, T., & Nagel, B., 2012. Aeroelastic Design and Optimization of Unconventional Aircraft Configurations in a Distributed Design Environment. 53rd AIAA/ASME/ASCE/AHS/ASC Structures, Structural Dynamics and Materials Conference. Honolulu (HI).
- Cronin, M. J., 1983. All-Electric vs Conventional Aircraft: The Production/Operational Aspects. *AIAA Journal of Aircraft*, 20(6), 481-486.
- Fioriti, M., 2014. Adaptable conceptual aircraft design model. *Advances in Aircraft and Spacecraft Science*, 1(1), 43-67. doi:10.12989/aas.2014.1.1.043
- Fioriti, M., Boggero, L., Corpino, S., Isyanov, A., Mirzoyan, A., Lombardi, R., & D'Ippolito, R., 2017. Automated Selection of the Optimal On-board Systems Architecture. 18th AIAA/ISSMO Multidisciplinary Analysis and Optimization Conference. Denver (CO).
- Giannakakis, P., Laskaridis, P., & Pilidis, P., 2011. Effects of Offtakes for Aircraft Secondary-Power Systems on Jet Engine Efficiency. *Journal of Propulsion and Power*, 27(5), 1024-1031.
- Jones, R. I., 2002. The more electric aircraft—assessing the benefits. *Proceedings of the Institution of Mechanical Engineers, Part G: Journal of Aerospace Engineering*, 216(5), 259-269.
- Liscouët-Hanke, S., 2008. A Model-Based Methodology for Integrated Preliminary Sizing and Analysis of Aircraft Power System Architectures. Doctoral Thesis.
- Prakasha, P.S., Boggero, L., Fioriti, M., Aigner, B., Ciampa, P.D., Anisimov, K., Savelyev, A., Mirzoyan, A. and Isyanov, A., 2017. Collaborative system of systems multidisciplinary design optimization for civil aircraft: AGILE EU project. Paper presented at the 18th AIAA/ISSMO Multidisciplinary Analysis and Optimization Conference, 2017.
- Prakasha, P. S., Ciampa, P. D., Boggero, L., & Fioriti, M., 2016a. Assessment of airframe-subsystems synergy on overall aircraft performance in a Collaborative Design. 17th AIAA/ISSMO Multidisciplinary Analysis and Optimization Conference. Washington D.C. (USA).
- Prakasha, P. S., Ciampa, P. D., Boggero, B. N. L., & Fioriti, M., 2016b. Collaborative systems driven aircraft configuration design optimization. Paper presented at the 30th Congress of the International Council of the Aeronautical Sciences, ICAS 2016
- Rosero, J. A., Ortega, J. A., Aldabas, E., & Romeral, L. A. R. L., 2007. Moving towards a more electric aircraft. *IEEE Aerospace and Electronic Systems Magazine*, 22(3), 3-9.
- Scholz, D., 2002. Aircraft Systems - Reliability, Mass, Power and Costs. EWADE.
- Scholz, D., 2009. Aircraft Systems Overview - Greening of Secondary Power Systems. SWAFEA - Sustainable Way for Alternative Fuels and Energy for Aviation. Brussels, Belgium.
- Zill, T., Ciampa, P. D., & Nagel, B., 2012. Multidisciplinary design optimization in a collaborative distributed aircraft design system. 50th AIAA Aerospace Sciences Meeting. Nashville (TN).

³<https://www.agile-project.eu/>