

The Polyvalent heat pumps technology in retrofit of existing HVAC systems

Original

The Polyvalent heat pumps technology in retrofit of existing HVAC systems / Vio, Michele; Becchio, Cristina; Corgnati, Stefano Paolo; Crespi, Giulia; Babuin, Michele; Morassutti, Silvia. - In: ENERGY PROCEDIA. - ISSN 1876-6102. - 133:(2017), pp. 158-170. [10.1016/j.egypro.2017.09.381]

Availability:

This version is available at: 11583/2698591 since: 2018-03-01T12:16:28Z

Publisher:

Elsevier Ltd

Published

DOI:10.1016/j.egypro.2017.09.381

Terms of use:

This article is made available under terms and conditions as specified in the corresponding bibliographic description in the repository

Publisher copyright

(Article begins on next page)



Climamed 2017 – Mediterranean Conference of HVAC; Historical buildings retrofit in the Mediterranean area, 12-13 May 2017, Matera, Italy

The Polyvalent heat pumps technology in retrofit of existing HVAC systems

Michele Vio^{a,*}, Cristina Becchio^b, Stefano Paolo Corgnati^c, Giulia Crespi^c, Michele Babuin^d, Silvia Morassutti^d

^a*RHOSS Consultant, Via delle Industrie 211, Arquà Polesine (RO) 45031, Italy*

^b*TEBE Research Group, Department of Regional and Urban Studies and Planning (DIST), Politecnico di Torino, Viale Mattioli 39, 10125 Torino, Italy*

^c*TEBE Research Group, Energy Department (DENERG), Politecnico di Torino, Corso Duca degli Abruzzi 24, 10129 Torino, Italy*

^d*RHOSS, Gruppo IRSAP, Via delle Industrie 211, Arquà Polesine (RO) 45031, Italy*

Abstract

In terms of existing buildings' retrofit, historical and non-residential buildings clearly represent two challenging categories. In historical buildings, due to architectural constraints, acting on the technical side is often the only way to reduce consumptions, while non-residential buildings usually require simultaneous production of hot and chilled water. In these cases, Polyvalent heat pumps represent an interesting solution, able to guarantee significant reductions of primary energy consumptions. In detail, a Reference Building for an historical office was simulated in three Mediterranean cities, using EnergyPlus software and some evaluation tools specifically set to emulate the energy performances of the examined HVAC technologies.

© 2017 The Authors. Published by Elsevier Ltd.

Peer-review under responsibility of the scientific committee of the Climamed 2017 – Mediterranean Conference of HVAC; Historical buildings retrofit in the Mediterranean area

Keywords: energy retrofit; heat generators; Polyvalent heat pumps technology; thermal insulation level.

1. Introduction

When considering historical buildings, it is important to bear in mind that the inclusion of an air conditioning

* Corresponding author. Tel.: +39-041-520-4701

E-mail address: michelevio@studiovio.it

system is always a complex operation [1]. Ordinarily, the original design of historical buildings does not include a centralized HVAC system, while fireplaces secured the heating of the main rooms. In some cases, in the first decades of the 20th century, a system of radiators was realized.

Nevertheless, the main difficulty is to find the locations for the generators, especially for heat pumps and chillers, for which it is often necessary to find open spaces. Heat pumps and chillers are not pleasant to see, especially in the context of a building characterized by important architectural value and historic significance. Consequently, they must be hidden or masked. The best solution is to place them in the upper parts of the building on existing terraces or creating suitable space acting on the profile of the roof. Moreover, in some cases, there could be the problem of the equipment weight. Indeed, probably, the original design of the historical building did not include weights so great and, for this reason, the structure of the building must be carefully verified.

Generally, in historical downtowns, background noise is very low (especially if there is no car traffic) and the buildings are very close to each other. The noise of the HVAC equipment must be carefully considered.

Moreover, the lack of useful space and the need to protect the architecture of the building very often prevents the installation of thermal or photovoltaic solar systems.

Finally, in historical buildings, the use of boilers is never easy, because often there is not a gas flue chimney or, when it is present, it still remains the problem of the structure fire protection. [2].

In these conditions, it is interesting to evaluate the use of a Polyvalent Heat Pump (HP) in place of traditional chiller and boiler. In the Mediterranean area, characterized by a temperate climate, a Polyvalent HP could be the only generator in the building, allowing a plant simplification and a space saving at the same time.

The aim of this research is to present the results obtained by using the Polyvalent heat pumps technology in historical buildings. In particular, a Reference Building for an historical office was simulated in three Mediterranean cities: Rome, Bari and Barcelona. The energy-dynamic simulation software EnergyPlus was used to model the office Reference Building and to evaluate the energy needs, while some energy-evaluation tools specifically set to emulate the energy behavior of the HVAC systems were used to assess consumptions.

2. Polyvalent Heat Pumps technology

A Polyvalent heat pump is a packaged heat pump equipped with a flexible and versatile heat recovery system, which can produce cooling only, or heating only, or cooling and heating at the same time. Each unit is equipped with three heat exchangers:

- a refrigerant-to-water evaporator to produce chilled water;
- a refrigerant-to-water condenser to produce hot water;
- a condenser/evaporator where heat rejection in cooling mode or heat absorption in heating mode takes place.

The latter heat exchanger can be a finned coil in case of air-cooled units, or a refrigerant-to-water heat exchanger in case of a water-cooled unit. In each operating mode, only two heat exchangers are activated.

Figure 1 represents the working principle of a Polyvalent heat pump. In particular, when only chilled water is required, the unit works as a normal chiller (A1 mode in Fig. 1). When chilled and hote water are simultaneously required, the unit switches to the heat recovery mode: the heat removed at the main heat exchanger (E) producing chilled water is rejected to the condenser (R) producing hot water (A2 mode in Fig.1). If only hot water is required, the unit switches to the heat pump mode, using the third heat exchanger as an evaporator and rejecting the heat to the condenser (C) producing hot water (A3 mode in Fig.1). The unit can change its operating mode at any moment, according to system requirements.

The operation modes just described are valid for a 4-pipes Polyvalent HP model. Anyway, a 2-pipes model also exists and the difference lies in the operation of the exchanger E of Figure 1: in a 4-pipes model, it works only as an evaporator, while in the 2-pipes model it works as an evaporator in the cooling mode and as a condenser in the heating mode.

The 2-pipes model is suited for seaside hotels used mainly in summer season, where there is never a need for heating, or whenever it is not possible to install a 4-pipes system.

Some manufacturers have a single version of Polyvalent HP: the operating mode switches from 2-pipes to 4-pipes simply by selecting the function on the microprocessor control.

All the energy analyses described in the following sections were performed considering a 4-pipes model.

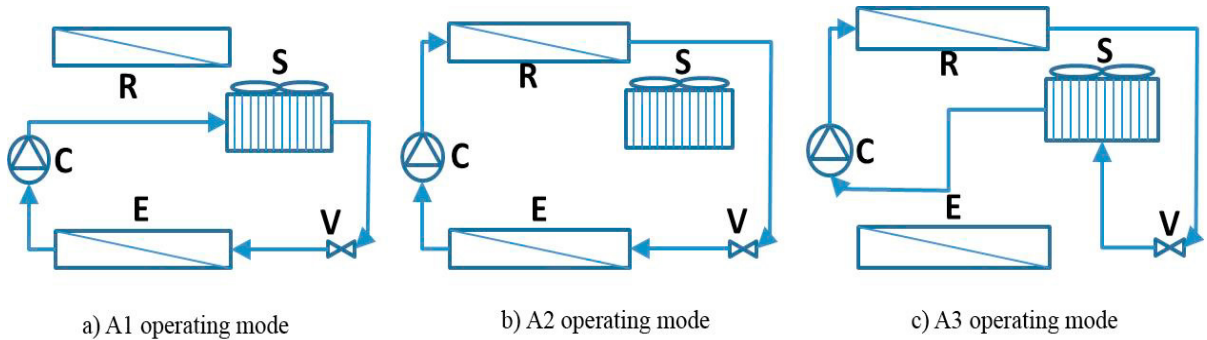

Fig. 1. Working principle of the single refrigerant circuit in a hybrid heat pump (C=compressor; V=expansion valve; E=evaporator; R=condenser; S=condenser/evaporator).

For both 2-pipes and 4-pipes models, the connections to the hydraulic circuits are very simple, as shown in Figure 2.

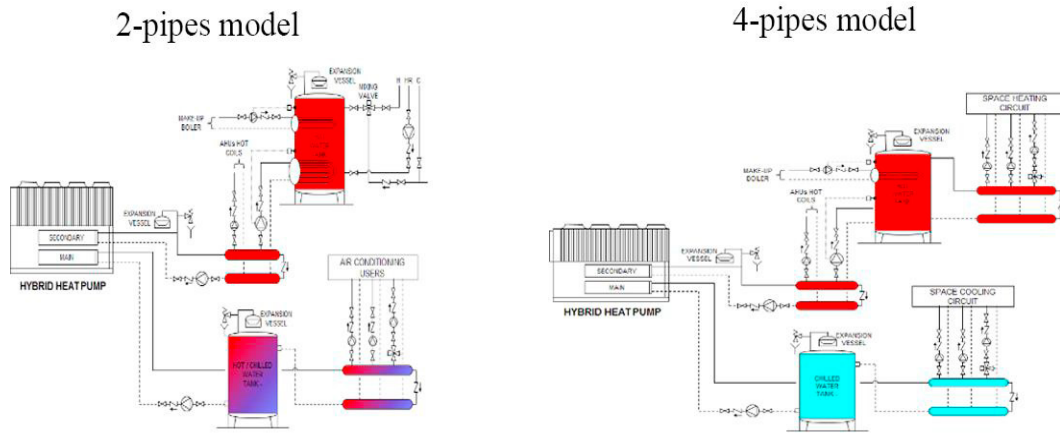

Fig. 2. Polyvalent HP connections to the hydraulic circuits.

2.1. Energy efficiency indexes

Polyvalent HPs are characterized by three energy indexes. In addition to Coefficient of Performance (COP), which measures the efficiency in heating mode (A3 operation mode in Fig. 1) and Energy Efficiency Ratio (EER), which measures the efficiency in cooling mode (A1 operation mode), the Total Energy Ratio (TER) index is considered. TER allows measuring the efficiency in total heat recovery operation mode (A2 operation mode in Fig. 1). The index is calculated as the ratio between the sum of cooling and heating energy produced simultaneously and the electrical energy consumed by compressors and auxiliaries. In other words, the TER index represents the sum of EER and COP indexes, when a Polyvalent unit works in recovery mode and its value is very high. In case the three indexes are used to indicate the seasonal performance, the S prefix is used: the indexes become respectively SCOP, SEER and STER.

It is important to consider that in the temperate Mediterranean climate, the heat pump SCOP reached is high. For this reason, the use of Polyvalent HPs is very advantageous, even when there is only thermal energy demand.

2.2. Polyvalent heat pumps vs. Traditional heat pumps

Polyvalent HPs permit to use them in a more flexible way than traditional ones.

First, traditional heat pumps cannot work in a 4-pipes system. Indeed, when there is a simultaneous demand of hot and chilled water, the units should be two: one connected to the hot water circuit and the other one connected to the

chilled water circuit. The refrigerant circuits would be separated, not taking any advantage of the heat recovery. In the case of traditional heat pumps, TER is not the sum of COP and EER, but the average of the two indexes, weighted on the energy flow. In summary, traditional systems would consume almost double energy with respect to Polyvalent heat pumps.

3. Reference Building for historical office

To assess the energy gains of Polyvalent HPs compared to the other generators in the case of historical buildings in the Mediterranean climate, it is necessary to perform reliable dynamic energy analysis.

A wide range of energy simulations for office [3] and hotel buildings was performed, in order to understand how the energy consumptions vary according to the structure of the building, the HVAC systems, the types of generators and other parameters related to the systems (i.e. regulation, pumps working mode, variation of air flow, etc.). The analysis was performed in cities with different climatic conditions.

In this study, the Reference Building (RB) for office is built starting from the American Department of Energy (DOE) database [4] and adjusting it in order to achieve the features of an historical edifice. The selected RB is a seven-storey office building, with a conditioned net floor area of 11620 m². The building has a rectangular plant, with the major façades North- and South-oriented. The model floor has a net floor area of 1660 m² and a net floor height of 2.7 m: a central core with distribution/service spaces constitutes it, while offices entirely occupy the perimeter area. Window-to-wall ratio is 33%.

The RB is assumed to be located in three Mediterranean cities: Rome, Bari and Barcelona, in order to assess the differences in terms of energy consumption as a function of the climatic conditions. All the construction typologies are selected from TABULA Webtool [5] for the period of construction 1901-1920. The sampled cities present different climates and legislations: for this reason, the construction typologies and the respective U-values differ according to the specific city. Table 1 summarizes the characteristics of the main envelope components and their relative U-values.

Table 1. Thermal features of the building envelope.

City	External Wall	External Roof	Ground Floor	Window
Rome	Brickwork 38cm plastered on both sides (U=1.48 W/m ² K)	Flat roofs with reinforced brick-concrete slab (U=1.46 W/m ² K)	Concrete slab with internal tiles (U=2.03 W/m ² K)	Single glazing, wood frame (U=4.9 W/m ² K)
Bari	Brickwork 50cm plastered on both sides (U=1.14 W/m ² K)	Flat roofs with reinforced brick-concrete slab (U=1.46 W/m ² K)	Concrete slab with internal tiles (U=2.03 W/m ² K)	Single glazing, wood frame (U=4.9 W/m ² K)
Barcelona	Brickwork 20cm plastered on external side (U=2.54 W/m ² K)	Flat roofs with reinforced concrete slab (U=3.07 W/m ² K)	Concrete slab with internal tiles (U=2.03 W/m ² K)	Single glazing, wood frame (U=5.3 W/m ² K)

Windows are equipped with internal venetians active only when incident solar radiation on the window surface is greater than 200 W/m². Regarding internal gains, occupancy is fixed to 8.4 m²/pers in all the offices [6] with the exception of the North-oriented ones, where the lower value of 16.8 m²/pers is set. In the central core occupancy is null. The schedule for occupancy, presented in Figure 3, is consistent with EN 15232:2012 [7] for office working days, while, during all other days, occupancy schedule is 0. Considering a typical sedentary activity, activity level is set to 0.9 met, while clothing resistance is equal to 1 clo and 0.5 clo for heating and cooling seasons respectively [8].

Lighting power density is defined as 3 W/m² (typical of LED systems). Lighting system is active only during working days, from 7:00 to 18:00, as established by EN 15232:2012 [7]. Equipment power densities are assumed as 10 W/m² and 3 W/m² in the offices and in the other service spaces respectively: the relative schedule, implemented from [7], is set to 1 during working days from 7:00 to 18:00 and to 0.05 in all the other hours, assuming the equipment stand-by. Moreover, specific electrical loads are fixed due to the presence of two servers per floor, equal to 251 W each, and an additional load of 32 kW is considered, on account of the elevator.

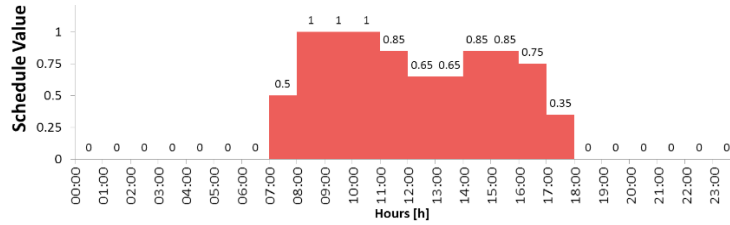

Fig. 3. Occupancy schedule for working days [7].

Air temperature set-points are fixed differently according to the distribution systems implemented, in order to compare the results obtained for equal thermal comfort conditions as reported in Table 2. HVAC systems function from 7 a.m. to 8 p.m. Heating system operates during the sole heating season, while cooling is active throughout the year; for each city, heating and cooling seasons are fixed in compliance with national regulations.

Table 2. Mean air temperature set-points and set-backs.

	Heating: set-points	Cooling: set-points	Winter Cooling: set-points
Fan-coil and VAV system	20 / 15°C	26°C	22°C
Radiant ceiling	18.75 / 15°C	27.5°C	20.75°C

Detailed sub-hourly simulations are conducted for each city, using the climatic conditions taken from DOE Weather for energy Calculation Database of Climatic Data [4].

3.1. Buildings' energy demands

Figure 4 shows the annual energy demands of three types of office buildings, an historical building and two new buildings with different levels of thermal insulation: one is set in compliance with the actual law (Law Insulation) and the other in accordance with future values fixed for 2021 (Future Insulation) [3]. The demands are related to the building structure and to the endogenous loads, but they do not consider the fresh air treatment.

As expected, when thermal insulation increases, the heating demand decreases, while the cooling one rises up.

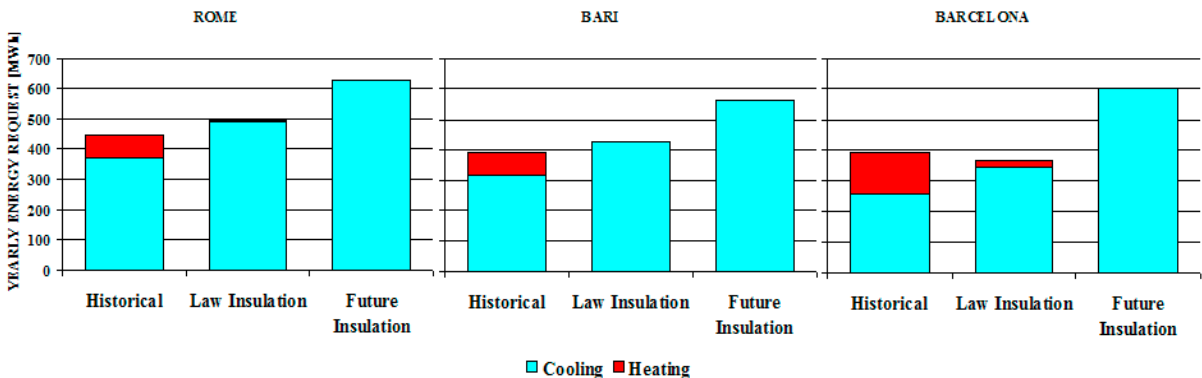

Fig. 4. Space heating and cooling demands.

4. Generators' power requirements

In order to define the energy requested to the generators, the energy requirements for the fresh air treatment and for the other components of HVAC systems must be added to those shown in Figure 4. In historical buildings, Variable Air Volume (VAV) systems usually cannot be used, due to the lack of usable space for the installation of air ducts. Consequently, the analysis considers only Primary Air (PA) systems combined with Fan-Coils (FC): two different solutions were examined, as expressed in Table 3.

Table 3. Examined solutions.

Solutions	Fresh air flow	Fan-coils inlet water temperature
PA1	40 m ³ per person: constant throughout the day	7°C constant
PA2	40 m ³ per person: variable with the real people presence	7°C, rising up to 14°C in function of sensible load

Furthermore, four different solutions for exhaust air heat recovery were examined:

- No heat recovery system: sometimes, in historical buildings, it is difficult to have enough space for air ducts installation. In these cases, a system without primary air should be used (assuming the same amount of fresh air of a primary air system without heat recovery).
- Sensible heat recovery.
- Enthalpy heat recovery.
- Sensible heat recovery assisted by Indirect Adiabatic Cooling (IAC).

Each recovery has 73% efficiency (sensible or total). The pressure drops are identical in all the heat recovery solutions: only for IAC an increase in the pressure drops due to the presence of a humidifier is considered.

Each of the eight examined solutions requires different loads to the generators. Figure 5 shows the power demand throughout the year for an office in Rome, in the case of sensible heat recovery. Each point represents the average power required at any hour of the year, from 1:00 am of the 1st of January to 12:00 pm of the 31st of December (red = heating, blue = cooling).

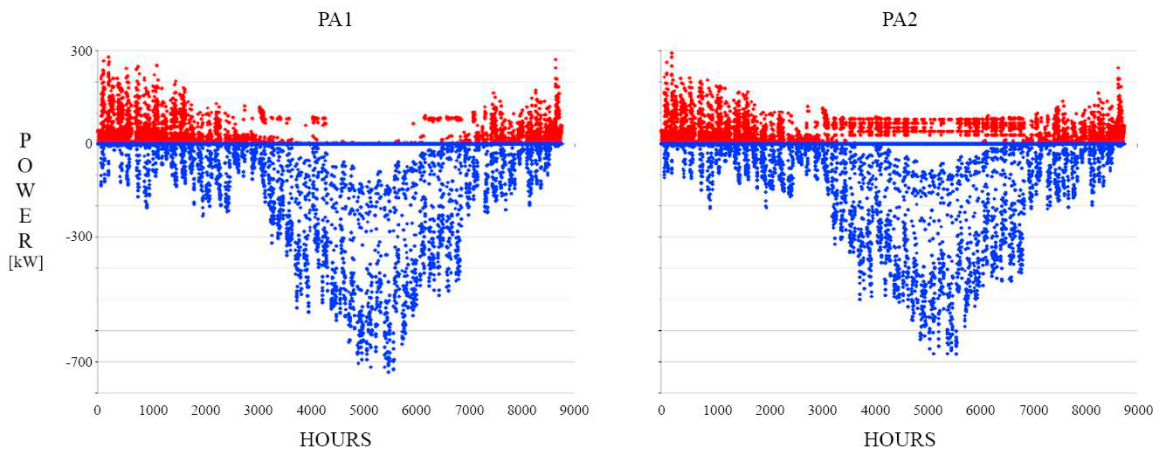

Fig. 5. Power requested to the generators, with sensible heat recovery, in Rome.

The PA2 system requires a lower power for many hours. The reasons are due to the facts that:

- the PA2 fresh air flow is often lower with respect to PA1 system, where the flow is constant (it varies with the occupancy);
- in PA1 solution, fan-coils are fed with water always at 7°C: sometimes relative humidity is lower than expected, with consequent higher energy consumption.

However, there is a greater demand for heating energy, especially in summer. This depends on the post-heating: the fan-coils are fed at a temperature above 10°C and they do not dehumidify, leaving this task to the Air Handling Unit (AHU).

Figure 6 shows the energy requested by the HVAC system to the generators for heating and cooling. Using a Polyvalent HP, part of the heating energy (orange area) is recovered while producing cooling energy (blue area).

If a boiler for heating and a traditional chiller for cooling are used, the boiler must produce the total heating energy (red + orange areas). The energy consumption would be higher due to the lower efficiency of the boiler compared to the Polyvalent HP, as well as for the non-exploitation of the condensing heat recovery during working in cooling.

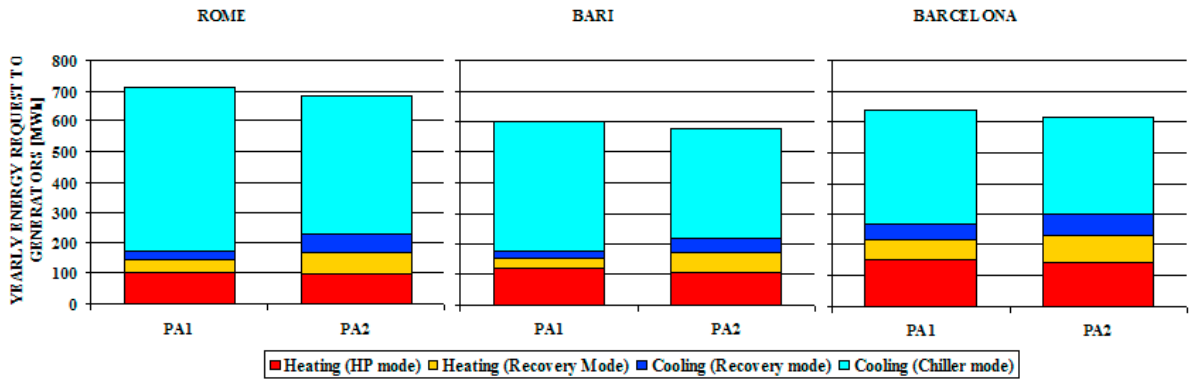

Fig. 6. Energy requested to generators by HVAC system.

Figure 7 shows the seasonal indexes of Polyvalent HPs in the three operation modes (Fig. 1): SCOP for heating mode, STER for recovery mode and SEER for cooling mode.

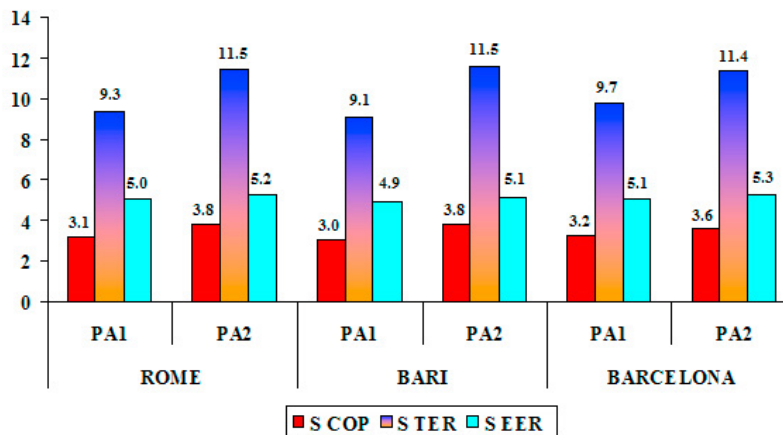

Fig. 7. Values of seasonal indexes for the three operating modes of a Polyvalent HP.

The values are higher for the PA2 system since:

- in cooling and heat recovery modes, the chilled water is produced at an higher temperature than in the PA1 system;
- in heating mode, the fresh air flow is lower in some hours of the day: the benefit is felt especially in the coldest days.

The indexes refer to a Polyvalent HP in Eurovent A class.

4.1. Optimization of air-to-water Polyvalent HPs for historical buildings

In historical buildings, the available spaces for the installation of air-to-water Polyvalent HPs are often limited. On the opposite, the Eurovent A Class units are generally bulky because they require high air flows to achieve high efficiencies in cooling mode.

In the case of historical buildings, dimensions are important, as well as the noise. To reduce the Polyvalent HP footprint, it is necessary to reduce the air flow to limit the length of the coils, thus reducing the EER index.

In order to optimize the Polyvalent HP, one solution is to reduce the total air flow of about 20% - 25%, leaving substantially unchanged the total annual electricity consumption. Consequently, it is necessary to increase the exchange surface of the two refrigerant-to-water heat exchangers (the condenser and the evaporator) to maintain the energy indexes high enough.

In this way, in the cooling mode, the increasing of evaporation pressure a little compensates the increment of condensing pressure. In this case, the EER value is lower, so the unit falls in C Class (according to Eurovent classification). However, COP index increases in heating mode, because the condensing pressure is lower. At the same time, the evaporation pressure decreases but with a lower influence compared to the previous gain. In recovery mode, the condensing pressure decreases and the evaporating pressure increases, with a substantial overall improvement of TER index. For this reason, a so-modified Polyvalent HP can be defined as a more compact optimized C Class unit for historical buildings.

Figure 8 shows the percentage variations of the seasonal indexes for an office in Rome. As shown, the SEER gets slightly worse, while the other two indexes significantly enhance.

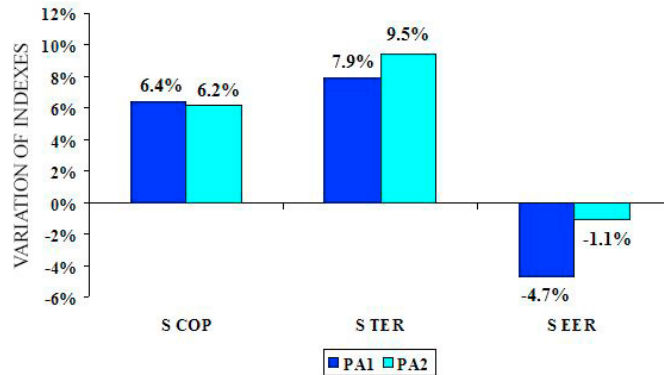

Fig. 8. Variation of seasonal indexes for a Polyvalent HP optimized for historical buildings (C Class unit, air flow 20% lower) compared to an Eurovent A Class, in Rome.

The SCOP gain is similar for the two types of system (PA1 and PA2). On the contrary, for PA2 solution, the STER gain is greater and the SEER loss is lower, confirming the higher performance of the PA2 system with respect to the PA1 solution.

As further described in the following paragraphs, the annual consumption remains unchanged, also with a more compact Polyvalent HP compared to a conventional A Class unit.

5. Analysis of the results

The number of results is considerable: for each building, 476 different combinations were considered. A summary is given below.

5.1. New energy parameter: the Photovoltaic Equivalent Surface

In order to express easily the order of magnitude of energy consumption and to render it understandable by anyone, a comparison parameter was identified, called Photovoltaic Equivalent Surface (PVES). It can be defined as the surface of a photovoltaic array required in order to bring to zero the difference between the annual electricity self-production and the overall consumption of the HVAC system, including auxiliaries [3, 9].

The Photovoltaic Equivalent Surface (PVES), expressed in m^2 , is calculated as follows:

$$PVES = 7 \cdot P_{PVpeak} = 7 \cdot \frac{EC_{tot} + (9.6 \cdot MC_{tot} \cdot 0.55)}{SEG_{Estim}} \quad (1)$$

Where:

- 7 is the required surface to reach 1 kW_{peak} power for the reference photovoltaic panel considered ($\eta_{el} = 14,4\%$), in m^2/kW_{peak} ;

- $P_{PV_{peak}}$ is the photovoltaic peak power needed to produce all the energy required to bring to zero the difference between the electricity self-production and the total consumption of the plant, in kW_{peak} ;
- EC_{Tot} is the total annual electricity consumption of the plant, included the auxiliaries (pumps and fans), in kWh;
- 9.6 is the specific heat capacity of natural gas, in kWh/m^3 ;
- MC_{Tot} is the yearly consumption of natural gas of a boiler, in m^3 ;
- 0.55 is the best electrical efficiency of the currently available electricity generation system powered by natural gas;
- SEG_{Estim} is the annual solar electricity generation estimated by JRC for 1 kW_{peak} of PV systems, in kWh/kW_{peak} : this value is equal to 1180 kWh/kW_{peak} in Rome, 1260 kWh/kW_{peak} in Bari and 1420 kWh/kW_{peak} in Barcelona.

To sum up, the lower the PVES value is, the lower the primary energy consumption will be and consequently, a lower PV array surface is needed to bring to zero the difference between the annual electrical energy consumed by the HVAC system and the self-produced electricity.

5.2. Energy savings of Polyvalent Heat Pumps

Polyvalent HPs allow maximizing the power conservation in the Mediterranean climate.

Figure 9 shows the energy consumptions of historical offices located in Rome, Bari and Barcelona, expressed in PVES. In case Polyvalent HPs are used, the PVES parameter is always lower with respect to the values obtained when using traditional solutions (chiller + boiler), whatever the type of heat recovery system used. This is mainly due to the increased efficiency of heat pumps compared to the boilers in heating mode, which is very high in the Mediterranean area climate.

Furthermore, the Polyvalent HPs exploit the working in total recovery mode, while this solution is not possible with traditional heat pumps. This ensures much greater gains, especially in case there is a simultaneous request of heating and cooling.

Figure 9 refers to A Class units, according to Eurovent classification. The consumption with optimized air-to-water Polyvalent HPs for historical buildings (C Class, see 4.1) are even slightly better, between 0.5% and 1% in Rome and Bari, about 2.5% in Barcelona.

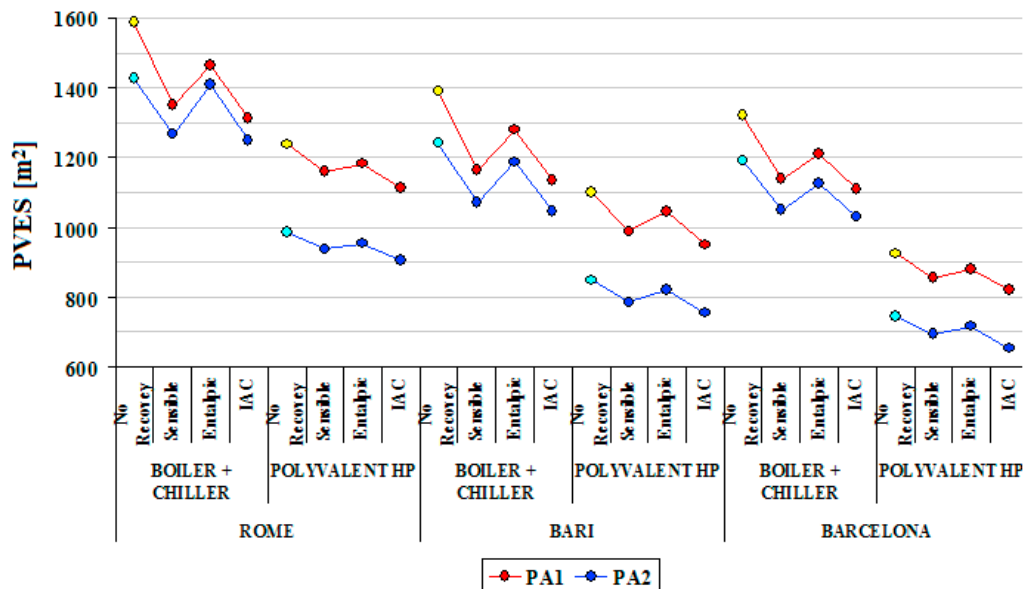

Fig. 9. Energy consumptions in PVES in the different European analysed cities.

Finally, Figure 9 shows that PA2 is always more efficient than PA1, for equal generators and exhaust air heat recovery systems.

It must be clarified why PA2 system gives more advantages when used with Polyvalent HPs rather than with boiler and chiller.

Figure 10 shows the differences in energy consumption of the various components, for the building located in Rome with sensible heat recovery, representing the gains due to the use of the PA2 solution with respect to the PA1 one.

The variation of the fresh air flow in accordance with effective occupancy levels always reduces AHU fans' consumptions of the same value for both boiler + chiller and Polyvalent HPs solutions, making it clear that the fans' consumption is completely independent on the type of generator used. To reduce the air flow with the occupancy is necessary to introduce appropriate dampers in the air ducts, connected to air quality sensors. The savings achievable are greater when the spaces available for the passage of the ducts are smaller and, therefore, this is a solution particularly suitable for historical buildings.

PA2 solution causes an increment of the pumps' consumptions, even if only slightly: this is due to the fact that fan-coils are actually fed with water at variable temperature between 7°C and 14°C and not always at a constant temperature of 7°C. So, for many hours, fan-coils work more and with greater water flow. For the same reason, PA2 solution also causes the increase of fan-coils' electric power consumption. Their power decreases with the increase of the water temperature and so the fans work for a longer time.

The reduction of chiller and Polyvalent HP consumptions is due to the water production at different temperatures, according to the HVAC system demand, both in cooling and heating. Obviously, the total amount is greater for Polyvalent HP: in fact, the variation of the produced water temperature affects more SCOP and STER than SEER.

The increased consumption of the boiler is due to the higher thermal energy required by the post-heating, in the case of the PA2 solution; in the Polyvalent HP this energy is totally recovered.

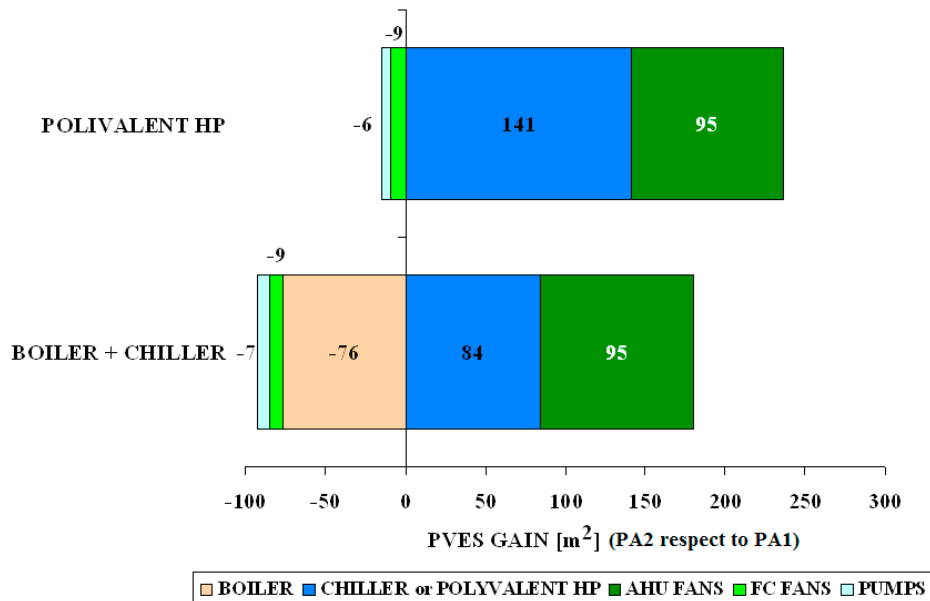

Fig. 10. Energy consumptions expressed in PVES.

5.3. Energy gains of exhaust air heat recovery systems

The Mediterranean climate is temperate, so the gain produced using heat recovery from the exhaust air is limited.

The theme would require a separate discussion. Just for completeness of information, it must be emphasized that the enthalpy heat recovery is ill suited to the Mediterranean climate, at least in the case of office buildings, as it can be seen in Figure 9; energy consumption is always higher with respect to sensible heat recovery or IAC. The latter is

the best solution in all the examined situations.

The analysis also considered the adoption of recovery run around coils. The results are not reported, but it is significant to report that they can reduce the PVES parameter of a value between 15 and 25 m², depending on the location, in case of Polyvalent HPs and PA2 systems (much more in case of boiler + chiller and much less in the case of system PA1).

5.4. Importance of hydraulic circuits with variable water flow

In order to minimize the plant energy consumption, when it is possible, it is needed to:

- Install buffer tanks on the primary circuits. The ideal size would be 10 litres per kW of thermal power. In historical buildings, this is not always possible, for reasons of available space. However, generally, the greater the water content is, the greater the efficiency of the system will be;
- Use pumping systems on secondary and primary circuits: in this latter case, a dual-pumps system should be adopted [2].

Figure 11 shows the comparison between systems that adopt (Best) or not (Worst) these solutions. If a constant water flow is used in primary and secondary hydraulic circuits, energy consumption increases. Figure 11 is valid for sensible heat recovery and PA1 solution. However, energy losses are similar also when using the PA2 solution and other types of exhaust air heat recovery.

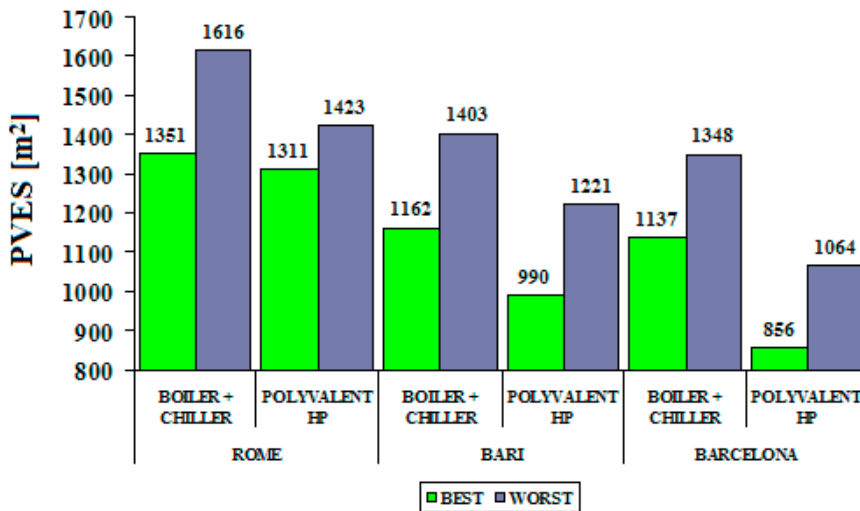

Fig. 11. Differences between best and worst solutions in the different European analysed cities.

5.5. Comparison with new buildings

It is interesting to see how the consumptions of historical buildings may differ from the ones of new buildings. Figure 12 shows this comparison for buildings located in Rome and Barcelona. The red curves identify the historical offices, the blue ones the offices insulated in accordance with current laws (Law insulation), while the green curves show the offices with higher levels of insulation, in compliance with future regulations fixed for 2021 (Future insulation).

The graph clearly shows that historical buildings have greater consumptions than law-insulated buildings. Anyway, it is possible to note that these differences are greatly reduced when using the Polyvalent HPs technology. Indeed, the consumptions of historical buildings with Polyvalent heat pumps are always much lower than the ones of new buildings with traditional generators installed (boiler + chiller).

As stated above, the green curves identify offices insulated in accordance with future U-values (fixed for 2021). It

is significant to see that the consumptions of offices with Future insulation are always higher than the ones of the other examined buildings. Figure 12 allows considering that, in the Mediterranean climate, it is not convenient to insulate the buildings too much, since this solution can cause major energy consumptions.

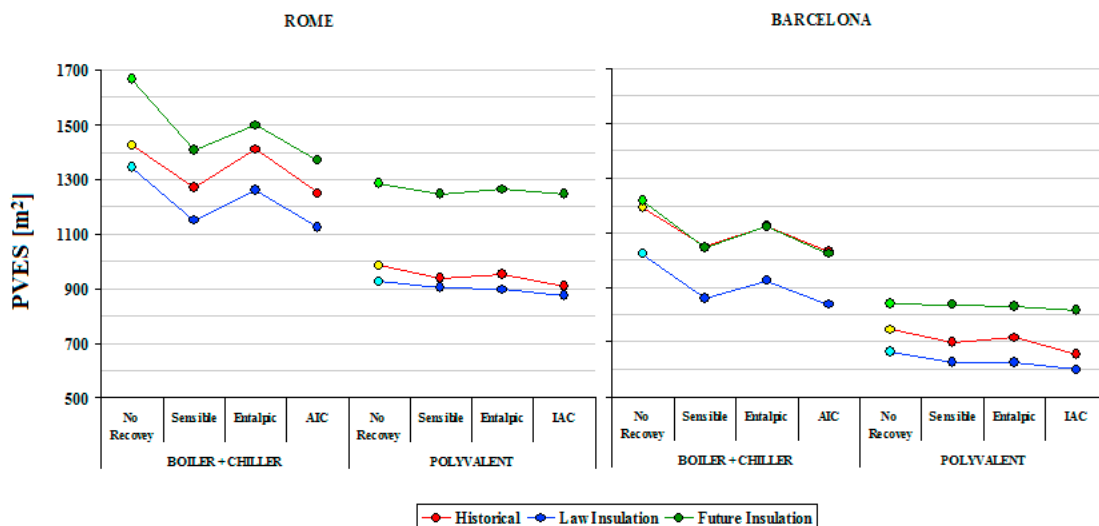

Fig. 12. Comparison between historical and new buildings.

6. Conclusions

The Polyvalent heat pumps technology is very advantageous in historical buildings, especially in the Mediterranean climate. Polyvalent HPs represent a good solution also for other types of non-residential buildings, as the hotels, taking advantage of the free hot water production in recovery mode. For more details there is another similar study related to this topic [9].

From the point of view of the installation, the major advantage is the use of a single generator, to produce both chilled and hot water, with dimensions similar to the ones of a traditional chiller.

Furthermore, in case of buildings with no places where to pass the chimneys, the presence of a Polyvalent HP instead of a boiler solves the problems related to the structure fire protection.

The technology of Polyvalent HPs allows reaching significant energy savings: the effect of the installation of this system in an historical building is often much greater than a hypothetical increment of thermal insulation to reach smaller U-values.

References

- [1] Boeche A, Rigo M, Vio A, Camuffo M, VRF systems in the renovation of historical buildings: the case of Palazzo Contarini del Bovolo in Venice, proceedings of Aicarr Conference, Rome, 2014.
- [2] Vio M, Germano L, Babuin M, HVAC systems with variable primary flow: analysis on energy potential saving, proceedings of Aicarr Conference, Matera, 2017.
- [3] Corgnati SP, Becchio C, Vio M, Prendin L, Magagnini M, Global building consumption: design choices influence, proceedings of Aicarr Conference, Padova, 2016.
- [4] Energy.gov, Office of Energy Efficiency & Renewable Energy, 2017. Available at: <http://energy.gov/eere/buildings/commercial-reference-buildings>, Last access: January 2017.
- [5] TABULA Webtool, 2017. Available at: <http://webtool.building-typology.eu/#bm>, Last access: January 2017.
- [6] UNI 10339:1995, Impianti aeraulici ai fini di benessere. Generalità, classificazione e requisiti. Regole per la richiesta d'offerta, l'offerta, l'ordine e la fornitura, Milan: Italian Unification Body, 1995.
- [7] EN 15232:2012, Energy performance of buildings – Impact of Building Automation, Controls and Building Management, Brussels: European Committee for Standardization, 2012.

- [8] EN 15251:2007, Indoor environmental parameters for assessment of energy performance of buildings, addressing indoor air quality, thermal environment, lighting and acoustics, Brussels: European Committee for Standardization, 2007.
- [9] Becchio C, Corgnati SP, Vio M, Prendin L, Magagnini M, Crespi G, HVAC solutions for energy retrofitted hotel in Mediterranean climate, proceeding of Climamed Conference, Matera, 2017