

How much is the advisable self-sufficiency of aggregated prosumers with photovoltaic-wind power and storage to avoid grid upgrades?

Original

How much is the advisable self-sufficiency of aggregated prosumers with photovoltaic-wind power and storage to avoid grid upgrades? / Spertino, Filippo; Ahmad, Jawad; Ciocia, Alessandro; Di Leo, Paolo. - ELETTRONICO. - (2017), pp. 1-8. (Industry Applications Society Annual Meeting, 2017 IEEE Cincinnati, OH (USA) 1-5 Oct. 2017) [10.1109/IAS.2017.8101712].

Availability:

This version is available at: 11583/2692746 since: 2020-03-01T10:40:20Z

Publisher:

Institute of Electrical and Electronics Engineers (IEEE)

Published

DOI:10.1109/IAS.2017.8101712

Terms of use:

This article is made available under terms and conditions as specified in the corresponding bibliographic description in the repository

Publisher copyright

(Article begins on next page)

How much is the Advisable Self-sufficiency of Aggregated Prosumers with Photovoltaic-Wind Power and Storage to Avoid Grid Upgrades?

Filippo Spertino

Senior Member, IEEE
Politecnico di Torino
Corso Duca Abruzzi, 24
Torino, TO 10129, Italy
filippo.spertino@polito.it

Jawad Ahmad

Politecnico di Torino
Corso Duca Abruzzi, 24
Torino, TO 10129, Italy
jawad.ahmad@polito.it

Alessandro Ciocia

Student Member, IEEE
Politecnico di Torino
Corso Duca Abruzzi, 24
Torino, TO 10129, Italy
alessandro.ciocia@polito.it

Paolo Di Leo

Member, IEEE
Politecnico di Torino
Corso Duca Abruzzi, 24
Torino, TO 10129, Italy
paolo.dileo@polito.it



Abstract – This paper defines, with respect to the consumption, the maximum value of self-sufficiency that can be reached by users, who decide to install photovoltaic (PV) modules, wind turbines and electrochemical storage. The primary goal of the aggregated users, who become prosumers, is assumed the achievement of the best match between power profiles of loads and power profiles of generators. Such best match is obtained thanks to an appropriate procedure to design the sizes of generators and storages. In this procedure, power ratings of PV and wind generators and energy capacities of batteries are chosen to attain the highest levels of self-consumption and the lowest power exchange with the grid according to the load profile. Thus, the upgrade of transformers and lines is avoided and there are benefits for both prosumers and grid operators. The simulation results are very realistic, because the inputs, in terms of irradiances for PV modules, wind speeds for turbines and powers for loads, are accurate measurements. The return on investments is estimated according to current costs and market rules. The results can be useful to plan the future electricity mix in the Mediterranean areas.

Index Terms- Photovoltaic power systems, wind power generation, energy storage, self-sufficiency, grid upgrade.

I. INTRODUCTION

A paramount drawback of power systems based on Renewable Energy Sources (RES) is their intermittency in energy production, which results in stability problems of the electricity grid and power quality issues. In different countries, such as Denmark for wind, have become the main sources of power. In Germany and Spain, Photovoltaic (PV) and wind share is around 20%, while in Italy this goal will be reached in a few years [1]. In every case, a transformation of the power system will be necessary: infrastructure, policies and markets have to be improved.

To compensate for the intermittency of PV and wind generators, with respect to hydroelectric pumping systems which require large reservoirs, electrochemical storages are easy to install and manage in whatever site. Their widespread utilization addresses the power balance of local loads and distributed generators mitigating RES negative effects on the grid [2]. For example, the power surplus from PV near midday may be used later to feed local loads. Nevertheless, electrochemical storage is currently expensive and cannot solve the problem of the weak seasonal correlation between low demand and high RES generation and vice versa. Thus, it is fundamental to know the acceptable amounts of grid-connected RES and storages capacities. In particular, the maximum capacities of intermittent RES must be defined, in order to avoid grid upgrade. By minimizing the power exchange with the grid, a reinforcement of distribution transformers and lines (for high reverse flow of active powers in radial networks originally designed to feed purely passive loads [3]) is avoided. Taking into account these general remarks, the optimal power sharing among PV generators, wind turbines, storage and grid to feed different users is determined in this paper. These three technologies are sized to meet a substantial amount of the demand, while the distribution grid provides the remaining power.

The electrical consumers are the owners of PV generators, wind turbines and storage systems: the consumers, thus, became prosumers. The primary goal of prosumers is assumed the achievement of the best match between power profiles of loads and power profiles of generators. Such a best match is obtained thanks to a suitable

procedure, in which the power ratings of PV and wind generators and energy capacities of batteries are chosen to attain the highest levels of self-sufficiency, with respect to the consumption, and the lowest levels of power exchange with the grid.

In every case, the selected sizing solutions are cost-effective (Net Present Value, $NPV > 0$) and cannot create problems to the grid management (overloads of transformers and distribution lines are avoided).

In this paper, the energy and economic results, related to the aggregation of several loads with a total maximum power of 85 MW are presented. In Italy the peak consumption was ≈ 53.6 GW in 2016. As shown in Fig.1, its typical daily load profile is quite similar to national consumption in Italy [4]: the peak load occurs during daylight hours. The main difference regards the higher base load of the case study ($\approx 80\%$ of the peak), while it is 60% at national level. This high base load has a negative impact in the task to completely meet the loads, certainly for PV power (zero in the night) and sometimes for wind power. Actually, the aggregated loads under study in this paper represent a worse case than the national power profile.

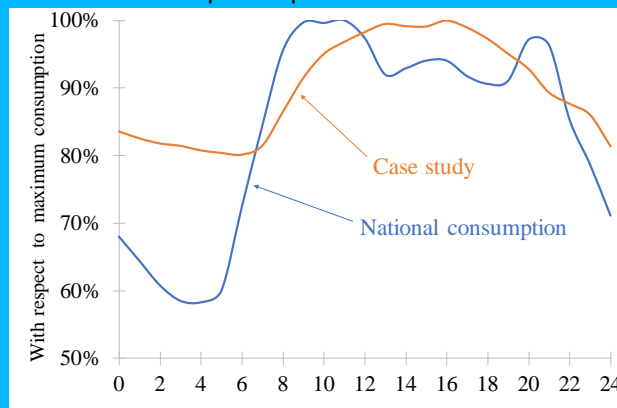

Fig. 1. Daily consumption profiles of Italy and the case study.

The method presented in this paper can be applied to national level, provided that detailed local data about solar irradiance and wind speed resources and aggregated loads are known. Thus, such an application to national level will provide higher figures in terms of self-sufficiency, by means of PV and wind power, for the whole country.

The next sections of this paper will be organized as follows. In the second section a description of the system architecture and information about the meteorological inputs will be presented. The models of system components and the description of load profiles are presented in the third section. In the fourth section the optimization procedure and the simulation constraints are described. The power flow management and the results of the simulations are discussed in the fifth and sixth section, respectively. The last section will contain the conclusions.

II. THE SIMULATED PV-WIND-STORAGE SYSTEM

A. Presentation of the System

A scheme of the system under study is presented in Fig. 2. Five different sites in Southern Italy are considered for the sizing procedure of the RES generators. These locations have a maximum mutual distance of 150 km. In each site, the load is the aggregation of electronic equipment for tele-communications and tertiary sector users (offices) with a peak consumption of about 85 MW. The components of the generation are PV modules, Wind Turbines (WTs) and electrochemical Battery Energy Storage Systems (BESS). In Fig. 3 for one site, these devices are connected to a DC bus, whose voltage is imposed by the batteries. DC-AC converter racks connect the DC bus to the AC grid (no DC loads). The DC-AC converters are unidirectional, because PV and wind generators recharge the storage without the grid contribution. The reason is that the main goal is to maximize self-sufficiency and minimize power exchanges with the grid. Hence, the use of storage for power exchange at different prices for

profit is not considered. The PV generators are equipped with Maximum Power Point tracker (MPPT) to extract the maximum power in every irradiance and temperature condition.

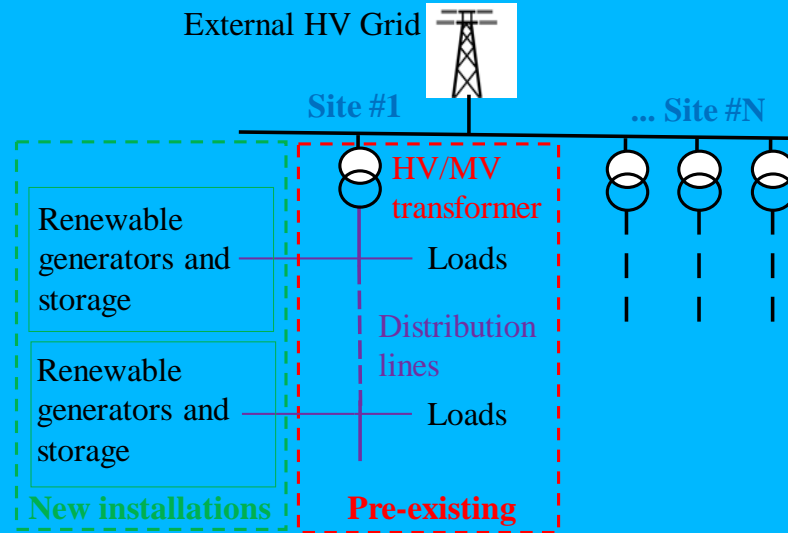

Fig. 2. Distributed RES generation and storage for prosumers.

The wind turbines are equipped with synchronous generators. Gearboxes are avoided (direct drive) and electronic converters (AC-DC) rectify the AC voltage, at low and variable frequency, for the DC bus.

Batteries have a dynamic nature; actually, they operate outside the equilibrium state due to continuous charge-discharge cycles. Even under normal operation, degradation takes place and is accelerated by other causes, such as not optimal charging patterns, overcharging, extreme temperatures and undercharging. Thus, the BESS includes a Battery Management System (BMS). It is necessary to reduce the degradation and improve system efficiency and lifetime. BMS is an integrated (hardware/software) system which continuously measures and processes currents, voltages and temperatures. Using physical models [5], BMS estimates the batteries' State of Charge (SOC) and the State Of Health (SOH) [6]. In case of large systems, many battery packs are series/parallel connected to create high capacities. Researchers are working on improved BESSs, which minimize the negative effects of temperature gradients and mismatch in batteries' I-V curves [7]. In this paper, a simulation of the continuous monitoring of quantities is not needed, because the storage systems are used to provide an estimation of prosumers' self-sufficiency.

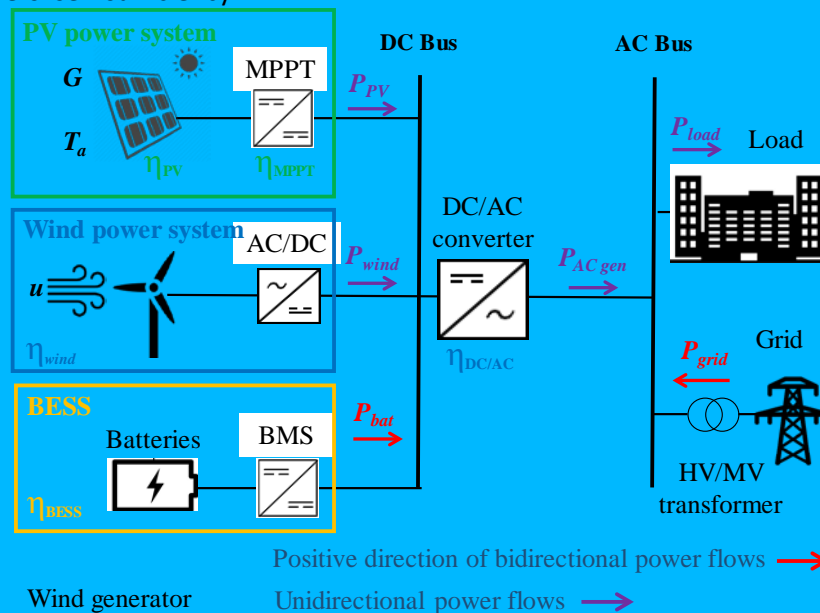

Fig. 3. The RES based system under study.

Thus, the simulated BMS is able to avoid deep discharges and overcharges by using an energy model to calculate the values of SOC. It is a function of the SOC at the previous time step and of the energy balance between generation and consumption; self-discharge rate and charge/discharge efficiencies are constant parameters. When the storage is disconnected to avoid deep discharges, loads must be fed by the grid. In the same way, when the storage is full, it is disconnected and the RES generation injects power into the grid. Details about the BMS simulation are in Section III.

B. Accurate Measurements as Inputs for the Simulation

The simulation results are very realistic, because the inputs, in terms of irradiances for PV modules, wind speeds for turbines and active powers for loads, are accurate measurements. Five meteorological stations located in Southern Italy, at latitudes within 39°–41°N, provide with 1-min time step many physical quantities. Global irradiances are measured by pyranometers (ISO secondary standards) on South oriented surfaces (horizontal plane and inclination of 30°). Wind speeds are measured by cup anemometers and wind vanes at 3 m height with respect to the ground. Thermo-hygrometers are used for air humidity and temperature. In the case of solar irradiance, the measurement uncertainty is in the range 15–25 W/m² [8]. The measurement range of wind speed is up to 50 m/s, while accuracy is ±0.2–0.3 m/s; in case of wind direction, accuracy is ±5°. The availability of the meteorological station is higher than 99% [9].

Energy counters (1% accuracy and 1-h averaging time) monitor active power of industry and tertiary sector loads. The first aggregation of loads exhibits an annual consumption of ≈112 GWh with a base load of ≈10.6 MW and a peak of ≈18.5 MW. In this case, the number of users is =220. The aggregation of the power consumed in the five sites corresponds, in Fig. 4, to more than 900 users with a base load of ≈50 MW, a peak of 85 MW and an annual consumption of ≈530 GWh.

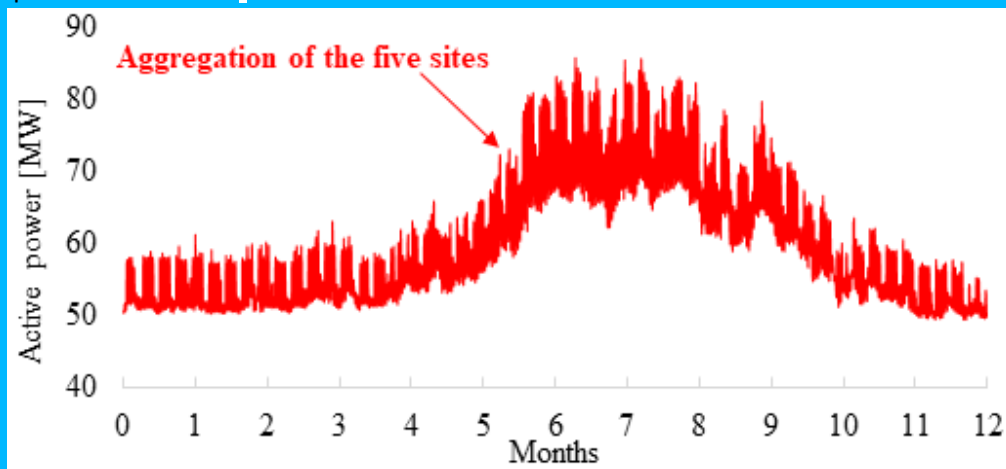

Fig. 4. Annual power profile of industry and tertiary sector loads.

III. SYSTEM MODELING

A. Modeling of PV Generators

The PV power profile is simulated starting from solar irradiance $G(t)$ and ambient temperature $T_a(t)$ evolutions. PV production is proportional to the capacity of PV generator (i.e., its rated or nominal power $P_{PV,nom}$ corresponding to Standard Test Conditions, $G_{STC} = 1 \text{ kW/m}^2$ and $T_{STC} = 25 \text{ }^\circ\text{C}$). According to the model defined in [10], the thermal losses depend on the thermal coefficient of PV technology and vary as a function of $G(t)$ and $T_a(t)$. The considered losses are caused by dirt (η_{dirt}) and reflection on the glass of PV modules (η_{refl}), low irradiance, electrical mismatch of I-V curves (η_{mis}), Joule effect in cables (η_{cable}) and MPPT (η_{MPPT}) [11]. Losses due to partial shadings are not considered in this study, because it is supposed a correct design of the PV system, which minimizes their impact.

B. Modeling of Wind Turbines

The link between the wind speed and the output power of horizontal axis wind turbines is strongly nonlinear. In stationary conditions, the mechanical power converted is a cubic function of the wind speed [12]. Manufacturers provide power curve of wind turbine as a function of wind speed. On this curve, the nominal power $P_{WT,nom}$ is defined as the value of its constant portion (≈ 12 – 25 m/s). Thus, it is possible to calculate the AC power output as a function of the wind speed data at the hub height. It is linearly interpolated to calculate the power output minute by minute. Obviously, it is necessary to transfer the measured wind data at the height of the turbine's hub by using a logarithmic formula [13], depending on anemometers' wind speed and terrain roughness. To select the best commercial WTs for the considered sites, it is advisable to calculate the global efficiency of a wind turbine [14]. The wind turbine with the efficiency peak near to the most frequent wind speed in the installation site is characterized by higher productivity.

The WT production is affected by wind turbulence, i.e., the fluctuations of the wind speed in a short time scale, e.g. 10 min. Turbulence is produced by two main causes. The first is the wind friction with the earth's surface: the perturbation induced by natural or artificial obstacles. The second is the vertical air mass movement due to air temperature variations. The turbulence increases the WT loading and fatigue effects [15], limited by stopping the WTs, when turbulence exceeds preset limits. Fig. 5 shows the impact of high turbulence on a daily power profile: the WT ($P_{WT,nom} = 850$ kW) is frequently stopped with a total reduction of $\approx 30\%$ on the energy output. The turbulence intensity τ is the ratio between the standard deviation of the wind speed fluctuations (σ) and the average wind speed (\bar{u}) at the height of the hub ($N = 10$ min):

$$\sigma = \sqrt{\frac{\sum_{i=1}^N (u_i - \bar{u})^2}{N-1}} \quad (1)$$

$$\tau = \frac{\sigma}{\bar{u}} \quad (2)$$

The Standard IEC 61400-1 [16] defines different levels of τ , for which WTs must be able to work. The maximum accepted value for power production is $\tau = 0.2$ (20%).

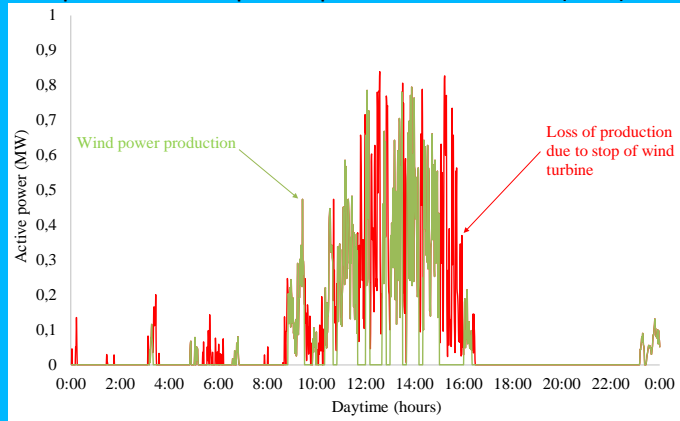

Fig. 5. Daily profile of wind production and turbulence losses.

C. Modeling of Storage System

In this work, an energy model of storage is used [17]. The behavior of batteries is modelled with a SOC value, min by min updated. The values of charging and discharging currents cannot exceed certain limits to reduce the battery degradation and ageing. The rated capacity $E_{bat,r}$ in kWh referred to a conventional discharge time and specifications of the commercial storage for RES applications, simulated in this work are reported in [18],[19]. Finally, concerning the storage replacement, during every step of the simulation, the amount of discharged power is integrated. It is compared with the maximum energy dischargeable by the storage E_{bat_life} , which is the product of the capacity of the battery $C_{bat,r}$, the rated voltage $V_{bat,r}$, the maximum number of cycles and the maximum Depth of Discharge (DOD):

$$E_{bat_life} = C_{bat,r} \cdot V_{bat,r} \cdot N_{cycle} \cdot DOD \quad (3)$$

If the limit E_{bat_life} is reached, batteries are replaced. If the limit E_{bat_life} is not reached before the lifetime declared by the manufacturer (10 years), newly the storage is replaced. Thus, the usage of batteries and their replacement affect the economic analysis.

D. Modeling of Power Converters

The power inputs from PV, WT and storage are converted by DC/AC converters, for which the efficiency η_{inv} takes into account the DC-AC losses. This efficiency is the ratio between the AC power delivered to the grid and the DC power inputs [20]. The DC/AC converters are partitioned into 55 kW racks connected in parallel to manage higher power levels. The number of converters depends on the power ratings of PV and WT systems. Their weighted average efficiency is 98.4%, while the maximum efficiency is 98.7%.

IV. OPTIMIZATION PROCEDURE AND CONSTRAINTS

A. Optimization Procedure

In order to be sure to achieve the optimal power sharing of PV, wind and storage, an exhaustive method is used. In particular, all the possible combinations of $P_{PV,nom}$, $P_{WT,nom}$ and $E_{bat,r}$ are investigated.

For each considered share of capacities, the energy and economic parameters are computed; then, all the results are stored in a database. The optimal share is obtained comparing the results of all the simulations.

The ranges in which sizes can vary are initially selected in order to be far from the optimal solution: then, they are updated by an iterative procedure. First, the range of variables are wide with large step: for example, for every case study the PV capacity can be evaluated from 0 up to 200 MW with 10 MW step. When the optimal solution is achieved with this step, it is possible to reduce both boundaries and steps. If the optimum is around 100 MW, the new range may become 80–120 MW with a step of 2 MW. With this kind of iterative method used for all the three variables, the exhaustive research of the optimum conditions is not too time expensive and the final solution is certainly the right one.

In case of generator capacities, the simulation can start from a threshold going down to zero. The size of storage is more difficult and the criteria for the starting point depends on the different goals. In case of the maximization of self-sufficiency, it is possible to start the simulation from a limit corresponding to a storage capacity which permits to store the 70% of produced energy from renewables, because it is supposed that the self-consumption performed without storage is at least $\approx 30\%$ [21]. In the case of maximization of NPV for the investment, it is suggested to omit the storage installation due to its current high cost.

B. Energetic and Economic Constraints

In every case study, the simulator calculates power profiles and cash flows. These data are used to exclude all the unacceptable solutions and find the optimal one, depending on the goal to be achieved. The first constraint is economic and excludes all the investments with a $NPV < 0$ (not cost-effective solutions). In addition, the Internal Rate of Return (IRR) is calculated, because it permits to compare the yield of different investments. Both the indicators, with the information of the initial cost, give a complete overview of the investment: in this paper, the interest rate is assumed $\approx 3\%$ for equity funds of prosumers. As described in [21], in case of new investments related to wind and/or PV power systems, the minimum acceptable IRR is $\geq 6\%$.

Regarding the costs, in case of storage system with high rated energy (> 1 MWh), the installation cost of Li-ion batteries is ≈ 300 €/kWh [18][19]. In case of wind turbines, it is 1300 €/kW, while Operation and Maintenance (O&M) costs are supposed $\approx 2\%$ of the installation cost (paid every year). In case of many megawatt, the installation cost of a PV plant is ≈ 1100 €/kW, while O&M costs are supposed $\approx 0.8\%$. The above mentioned costs are all inclusive. Regarding the energy exchange with the grid, the price paid to the user for the electricity injection into the grid [22], is ≈ 4 c€/kWh, while the average cost of absorbed electricity, for the tertiary sector, is ≈ 20 c€/kWh.

The second constraint in the optimization procedure is a limit on the maximum power injected in the grid: the injection peak has to be lower than the maximum load power measured during the entire year. The limitation in grid injection corresponds to a restriction in installable nominal power of PV and wind generators. As a result, current and power limits in every line are always respected and the annual energy injection cannot be too high. In this way, negative effects on the operation of the distribution grid, due to a high mismatch between load and generation profiles, are reduced.

V. POWER MANAGEMENT AND SIMULATION RESULTS

The simulator, developed ad hoc in MATLAB®, calculates power flows starting from RES production.

First, a combination of $P_{PV,nom}$, $P_{WT,nom}$ and $E_{bat,r}$ is selected. Then, generation profiles are calculated from solar irradiance, wind speed and air temperature by the models described in Section III. The production is compared with loads and the use of storage and external grid is evaluated. In the simulation, the storage control is based on SOC: storage can be full charged ($SOC_{max}=1$), empty ($SOC_{min}=0.2$) or partially discharged ($SOC_{min}<SOC(t)<SOC_{max}$). The control system checks if there is an energy deficit or surplus from renewables (with respect to the load), checks the SOC and decides if battery must be used. How much energy can be charged or discharged is defined according to limits imposed to preserve battery life. The first limit in storage use is the maximum power $P_{max,power}$ that can be absorbed or injected into the batteries during a time step. It is a power value generally defined in the datasheet of the device in order to preserve battery life. In fact, a too fast charge or discharge can damage the batteries. The second limit is the maximum energy that can be provided in a time step by the storage without exceeding the SOC_{min} — SOC_{max} range. In the case of discharge, it is:

$$P_{stor,dis} = (SOC(t) - SOC_{min}) \cdot E_{bat,r} / \Delta t \quad (4)$$

The two limits ($P_{stor,dis}$ and $P_{max,power}$) are compared and the minimum is considered. The same procedure is applied in case of battery charge. Now, the role of the grid is discussed. If storage is not sufficient to handle the power in the local system, the external grid is used to feed the loads. In every case, the active sign convention is used. The six possible cases step by step are:

- CASE #1: Generation from renewables is higher than load $P_{ren} \geq P_{load}$ and storage is full $SOC(t) = SOC_{max}$;
- CASE #2: Generation from renewables is lower than load $P_{ren} < P_{load}$ and storage is full $SOC(t) = SOC_{max}$;
- CASE #3: Generation from renewables is higher than load $P_{ren} \geq P_{load}$ and storage is empty $SOC(t) = SOC_{min}$;
- CASE #4: Generation from renewables is lower than load $P_{ren} < P_{load}$ and storage is empty $SOC(t) = SOC_{min}$;
- CASE #5: Generation from renewables is lower than load $P_{ren} < P_{load}$ and storage is partially full $SOC_{min} < SOC(t) < SOC_{max}$;
- CASE #6: Generation from renewables is higher than load $P_{ren} \geq P_{load}$ and storage is partially full $SOC_{min} < SOC(t) < SOC_{max}$.

In the first case, storage is not working $P_{batt}=0$, because it is full and there is surplus of renewable production; thus, the external grid injection ($P_{grid}<0$) corresponds to the difference between RES production and load ($P_{grid} = P_{load} - P_{ren}$). As shown in Fig. 6, the fifth case is more interesting, because all the component of the systems could work. Renewable generators work, but their production is lower than load ($P_{ren} < P_{load}$). Storage is partially full $SOC_{min} < SOC(t) < SOC_{max}$; thus, it can help to feed the loads. If batteries can completely feed the rest of the load, the external grid is not used; otherwise, the grid helps to provide the deficit of production ($P_{grid} + P_{batt} + P_{ren} = P_{load}$).

Fig. 7 shows daily power profiles after the application of the optimization procedure for obtaining the Maximum Self-Sufficiency (M-S-S). During this day in spring with high irradiance and wind speed, RES production is high and loads are low, because cooling systems are shut-down. Wind production helps to feed loads during night till 5:00 am (CASE #5). Only for few hours (from 5:00 to 8:00 am) the grid helps to feed loads, because RES generation is low and batteries are empty (CASE #4). At $\approx 7:30$ am, RES production starts to be higher than loads (CASE#3) and during sunlight hours (till 5:00 pm) batteries are charged (CASE #6). The discharge begins in the afternoon ($\approx 4:30$ pm) and this situation corresponds to CASE#5. CASES #1 and #2 are not present in Fig. 7, because in this simulation the storage size is high and batteries do not reach full charge in this day.

An alternative strategy to increase the storage life may be the variation of the range SOC_{min} — SOC_{max} . Without varying the size of the storage, a smaller SOC range means a lower capacity usable to meet the consumption. The advantage of the variation of the SOC range may be the reduction of the number of round-trips with a consequent increase in lifetime.

In particular, this technique is effective in case of intermittent generators, because they cannot guarantee the correct charge-discharge profiles to preserve the battery life. In case of PV systems, it occurs mainly in cloudy-sky days, when rapidly changes in solar irradiance occur. Fig. 8, as an example, shows a cloudy day in July, in which there is a high fluctuation of PV production. From midday to 5:00 pm, PV generation varies between ≈ 10 and ≈ 35 MW. Recharge of batteries is possible between 10 am and midday. During the next 3 h, there is a frequent change between overproduction and underproduction. Then, the load is maximum (25 MW) from 3 to 4 pm and generation is low 10–18 MW. The last recharge of the day is possible between 4 and 6 pm. If the storage with nominal capacity of 20 MWh is used to maximize self-sufficiency, it has to compensate for these changes in the power flow direction.

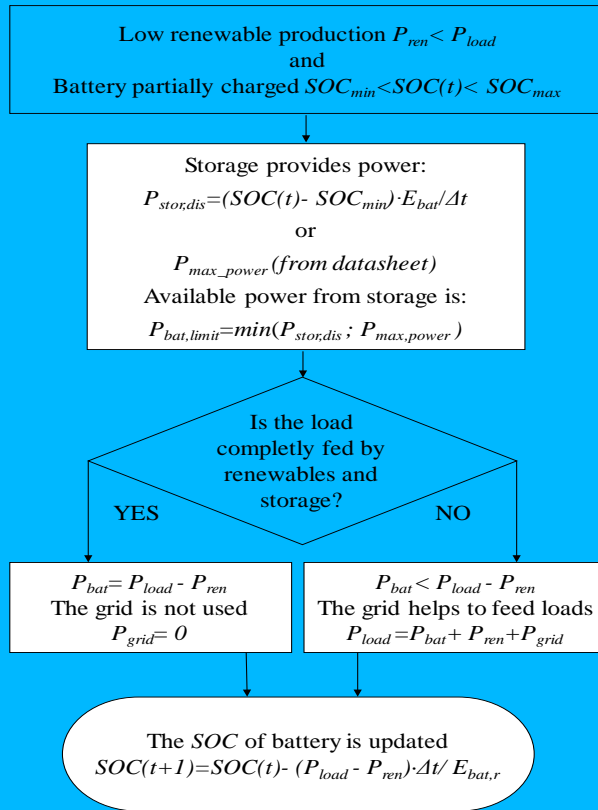

Fig. 6. Flow chart of Case #5.

Complete and optimal battery recharge cannot be performed and the number of partial round-trips is high. Fig. 9 shows two different strategies: in the case “a”, the minimum SOC is the manufacturer’s limit ($SOC_{min,a}=0.2$); in the case “b”, the minimum SOC is increased to $SOC_{min,b}=0.6$ to reduce partial cycles. Fig. 9 shows the central hours of the day, because before 8 am and after 8 pm batteries are empty.

In both cases, storage is initially empty $SOC=SOC_{min}$. Batteries can be partially recharged until midday, when there is high load but low and variable PV production due to clouds. In case “a”, the charge is stopped at 12:00, while in case “b” it is full at 11:30. In the same way, the charge of batteries is reduced starting from 1:00 pm.

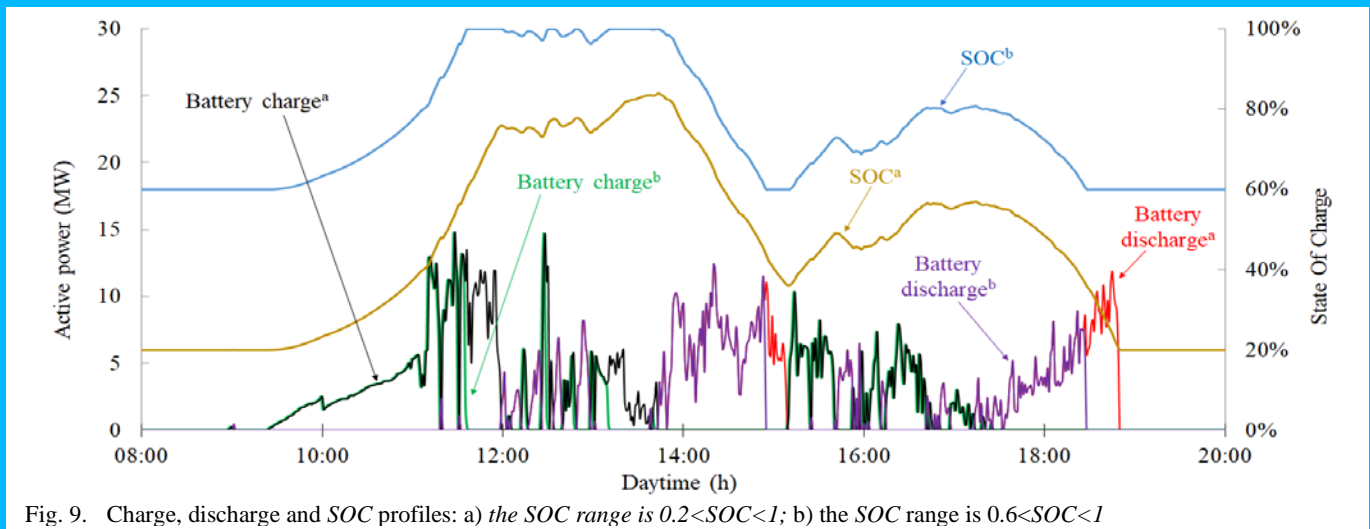

Fig. 9. Charge, discharge and SOC profiles: a) the SOC range is $0.2 < SOC < 1$; b) the SOC range is $0.6 < SOC < 1$

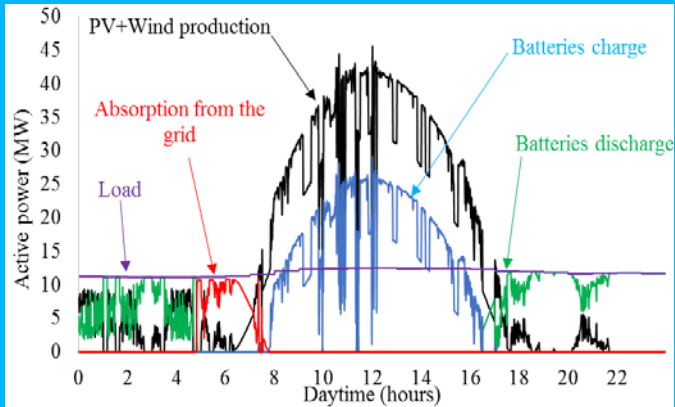

Fig. 7. Daily profiles of power flows with high solar irradiance and high wind speed- March 13th.

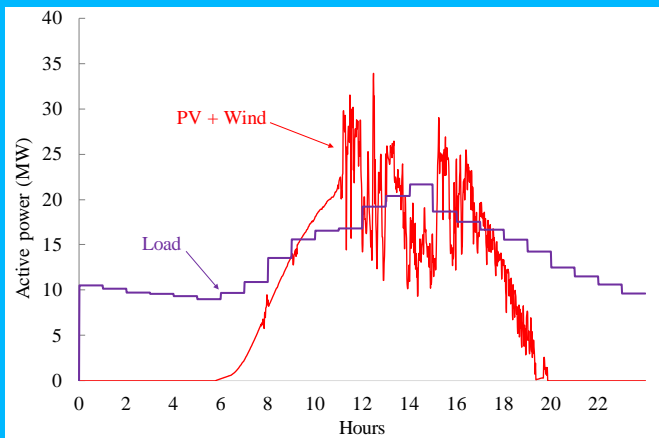

Fig. 8. Power profiles during a variable-sky day in summer.

Owing to the lower usable capacity, in case “b”, the discharge is stopped at 3 pm and at 6:30 pm, because the SOC is minimum. As a result, the daily energy discharged from batteries decreases by 35% (from 36 to 24 MWh) and the self-sufficiency decreases from 64% to 60% (from ≈ 210 to ≈ 200 MWh). In addition, in case “b” the power injection into the grid increases up to 5 MWh, while in the case “a” it is null. The advantage of the SOC_{min} increment is the reduction of partial charge-discharge cycles.

In the case “a”, the batteries provide energy (calculated as the integral function of the discharge intervals) equal to 3 times their available capacity. In the case “b”, the number of equivalent complete discharges is ≈ 2.3 . This saving obtained every day means that the extension of the battery life increases by 23%. Nevertheless, the previous example is a worst case, with respect to the case study, in which, on average, it occurs a single round-trip per day. As recommended by manufactures, after ten years, batteries must be replaced to guarantee the correct operation of the system but the number of performed cycles in this time is ≈ 3650 , lower than the warranty (≈ 5000 cycles). For this reason, in the case under study, the choice of reducing the DOD is not effective to increase the battery life: the result is only the decrease of the self-sufficiency and the replacement cannot be delayed after the 10th year.

The simulations of the aggregated consumption and RES generation profiles, subject to the grid constraints, permit to find the optimal capacities of generators and storage (Table I). In case of self-sufficiency maximization (M-S-S), this parameter reaches $\approx 55\%$ of the load. On the other hand, in case of the cost-optimal solution (C-O-S), this self-sufficiency is $\approx 40\%$ (Table II).

These figures of self-sufficiency depend on the energy computations which are affected by uncertainty. The measurement uncertainties of solar irradiance, wind speed and power consumed by the loads are well-known, as written previously. However, the uncertainties of the conversion models for PV, WT, storage and electronic converters are not negligible. Hence, it is assumed that the energy results are affected by uncertainties of $\pm 10\%$.

The highest autonomy from the grid is achieved by installing high renewable production (mainly PV) and storage capacity. Batteries permit to use many PV generators and wind turbines without grid injection, which is negligible with respect to the annual loads. The use of renewables (instead of buying energy from the grid) is so profitable

that it is possible to install a high storage capacity (even if its use is expensive with respect to the use of the grid) and obtain positive *NPVs* and *IRRs* >6%. Nevertheless, it is not cost-effective to reach the total independence from the grid. The reason is the presence of a constant and great base load: in order to store all the energy required by the load during the night, a too high battery capacity would be necessary. Thus, during many nights the load is partially fed by the grid until the PV production rises the next morning.

PV modules are preferred to wind turbines, even when the PV productivity is lower. In fact, the capacity factor of PV (17%) is lower of the capacity factor of wind (23%) and installation costs are similar. PV is preferred because PV profiles better match load profiles from both daily and seasonal point of views. In particular, wind farms have peak production during low load periods (e.g., during night and during winter); thus, the wind farm size is limited to reduce the reverse power flows.

TABLE I
POWER AND ENERGY CAPACITIES IN OPTIMAL SOLUTIONS

	M-S-S	C-O-S
<i>Power and Energy Capacities</i>		
PV power rating (MW)	180	90
WT power rating (MW)	29.5	55
Storage capacity (MWh)	630	0

TABLE II
ENERGETIC AND ECONOMIC SIMULATION RESULTS

	M-S-S	C-O-S
<i>Performance of generators (DC bus)</i>		
Capacity factor of PV	17%	17%
Capacity factor of wind	23%	23%
PV production (GWh/year)	264	133
Wind production (GWh/year)	65	124
<i>Energy flows (AC bus)</i>		
PV + wind production (GWh/year)	297	238
Load (GWh/year)	530	530
Self-sufficiency (GWh/year)	291	212
Absorption from grid (GWh/year)	238	318
Injection in the grid (GWh/year)	5	26
<i>Energy parameters</i>		
RES Energy/Load Energy	56%	45%
Self-sufficiency/Load Energy	55%	40%
Injected Energy/Load Energy	1%	5%
Self-sufficiency /RES Energy	99%	89%
<i>Economic parameters</i>		
NPV after 25 years (M€)	158.1	457.5
Initial investment (M€)	434.6	175.2
IRR (%)	6.4	20.6

VI. CONCLUSIONS

The main goal of this paper is to investigate the maximum energy share provided by the most important intermittent renewable sources (solar photovoltaic and wind power) to feed the aggregation of several users (industry and tertiary sector) which act as prosumers. To perform this task, accurate measurements of solar irradiance and wind speed from meteorological stations and of power consumed by loads from energy counters are used as inputs of the simulations by appropriate conversion models of these technologies. The management of this multigeneration park with storage is carried out, according to the different load conditions along the year,

to find a cost-effective solution which maximizes the self-sufficiency and minimizes the power exchange with the grid. By this solution which does not require grid upgrades, the self-sufficiency, within 50-60%, is much higher than the current RES share in the main European countries. In addition, also with the most profitable solution which requires to omit storage systems, the self-sufficiency, about 40%, is higher than the conventional limits of intermittent RES penetration stated by the utility grids.

REFERENCES

- [1] European Commission - Joint Research Center, «Smart Grid Projects Outlook 2014,» [Online]. Available: <http://ses.jrc.ec.europa.eu/smart-grids-observatory>.
- [2] F. C. L. Trindade, T. S. D. Ferreira, M. G. Lopes and W. Freitas, "Mitigation of Fast Voltage Variations During Cloud Transients in Distribution Systems With PV Solar Farms," in *IEEE Transactions on Power Delivery*, vol. 32, no. 2, pp. 921-932, April 2017.
- [3] F. Spertino, P. Di Leo, V. Cocina, "Which are the constraints to the photovoltaic grid-parity in the main European markets?," *Solar Energy*, vol. 105, pp. 390-400, 2014.
- [4] Italian Transmission System Operator (TERNA), "Trend of the electricity demand in real time," 2017. [Online]. Available: <https://www.terna.it/DesktopModules/GraficoTerna/GraficoTernaEsteso/ctlGraficoTerna.aspx?sLang=it-IT>
- [5] M. Einhorn, V. Conte, C. Kral, J. Fleig, "Comparison of electrical battery models using a numerically optimized parameterization method," in *IEEE Vehicle Power and Propulsion Conference*, Chicago, USA, 2011.
- [6] M. Cacciato, G. Nobile, G. Scarcella, G. Scelba, «Real-Time Model-Based Estimation of SOC and SOH for Energy Storage Systems,» *IEEE Transactions on Power Electronics*, vol. 32, n. 1, pp. 794-803, 2016.
- [7] M. T. Lawder et al., "Battery Energy Storage System (BESS) and Battery Management System (BMS) for Grid-Scale Applications," in *Proceedings of the IEEE*, vol. 102, no. 6, pp. 1014-1030, June 2014.
- [8] A. Carullo, F. Ferraris, A. Vallan, F. Spertino, F. Attivissimo, Uncertainty analysis of degradation parameters estimated in long-term monitoring of photovoltaic plants, *Measurement*, Volume 55, September 2014, Pages 641-649.
- [9] F. Spertino, P. Di Leo, V. Cocina, «Accurate measurements of solar irradiance for evaluation of photovoltaic power profiles,» in *IEEE Grenoble Conference PowerTech*, Grenoble, 2013.
- [10] F. Spertino, F. Corona, P. Di Leo, "Limits of advisability for master-slave configuration of DC-AC converters in photovoltaic systems," *IEEE Journal of Photovoltaics*, vol. 2, pp. 547-554, 2012.
- [11] F. Spertino, A. Ciocia, P. Di Leo, R. Tommasini e I. Berardone, M. Corrado, A. Infuso, M. Paggi, «A power and energy procedure in operating photovoltaic systems to quantify the losses according to the causes,» *Solar Energy*, vol. 118, 2015.
- [12] Danish Wind Energy Associates (DWEA), 2016. [Online]. Available: www.windpower.org.
- [13] Danish Wind Industry Association, "Roughness Classes and Roughness Length Table," 2016. [Online]. Available: <http://xn--drmstrre-64ad.dk/wp-content/wind/miller/windpower%20web/en/stat/unitsw.htm#roughness..>
- [14] F. Spertino, J. Ahmad, G. Chicco, A. Ciocia, P. Di Leo, "Matching between electric generation and load: Hybrid PV-wind system and tertiary-sector users," 2015 50th International Universities Power Engineering Conference (UPEC), Stoke on Trent, 2015, pp. 1-6.
- [15] Y. Qiu, Y. Xu, J. Li, Y. Feng, W. Yang, D. Infield, "Wind turbulence impacts to onshore and offshore wind turbines gearbox fatigue life," 3rd Renewable Power Generation Conference (RPG 2014), Naples, 2014, pp. 1-5.
- [16] International Electrotechnical Commission, "IEC 61400-1:2005, Wind turbines - Part 1: Design requirements," [Online]. Available: <https://webstore.iec.ch/publication/5426>.
- [17] A. A. H. Hussein, I. Batarseh, "An overview of generic battery models," in *IEEE Power and Energy Society General Meeting*, San Diego, USA, 2011.
- [18] F. Spertino, A. Ciocia, V. Cocina and P. Di Leo, "Renewable sources with storage for cost-effective solutions to supply commercial loads," 2016 International Symposium on Power Electronics, Electrical Drives, Automation and Motion (SPEEDAM), Anacapri, 2016, pp. 242-247.
- [19] A. Oudalov, ABB Switzerland, Corporate Research, Energy Storage in Electric Power Systems - Integration of Renewable Energy Sources, Ispra, 2015.
- [20] J. Muñoz, F. Martinez-Moreno, E. Lorenzo, "On-site characterization and energy efficiency of grid-connected PV inverters," *Progress in Photovoltaics: Research and Applications*, vol. 19, p. 192-201, 2011.
- [21] A. Ciocia, J. Ahmad, G. Chicco, P. Di Leo e F. Spertino, «Optimal Size of Photovoltaic Systems with Storage for Office and Residential Loads in the Italian Net-Billing Scheme,» in *UPEC2016*, Coimbra, Portugal, 2016.
- [22] U.S. Energy Information Administration, "Levelized Cost and Levelized Avoided Cost of New Generation Resources 2016", <http://www.eia.gov>