

Embedded eigenvalues for water-waves in a three-dimensional channel with a thin screen

Original

Embedded eigenvalues for water-waves in a three-dimensional channel with a thin screen / CHIADO' PIAT, Valeria; Nazarov, Sergey; Taskinen, JARI JUHANI. - In: QUARTERLY JOURNAL OF MECHANICS AND APPLIED MATHEMATICS. - ISSN 0033-5614. - 71:2(2018), pp. 187-220. [10.1093/qjmam/hby002]

Availability:

This version is available at: 11583/2687248 since: 2019-02-11T21:59:53Z

Publisher:

Oxford Academic Press

Published

DOI:10.1093/qjmam/hby002

Terms of use:

This article is made available under terms and conditions as specified in the corresponding bibliographic description in the repository

Publisher copyright

(Article begins on next page)

EMBEDDED EIGENVALUES FOR WATER-WAVES IN A THREE DIMENSIONAL CHANNEL WITH A THIN SCREEN

VALERIA CHIADÓ PIAT, SERGEY A. NAZAROV, AND JARI TASKINEN

ABSTRACT. We construct asymptotic expansions as $\varepsilon \rightarrow +0$ for an eigenvalue embedded into the continuous spectrum of water-wave problem in a cylindrical three dimensional channel with a thin screen of thickness $O(\varepsilon)$. The screen may be either submerged or surface-piercing, and its wetted part has a sharp edge. The channel and the screen are mirror symmetric so that imposing the Dirichlet condition in the middle plane creates an artificial positive cut-off-value Λ_{\dagger} of the modified spectrum. Depending on a certain integral characteristic I of the screen profiles, we find two types of asymptotics of eigenvalues, $\blacksquare \lambda^\varepsilon = \Lambda_{\dagger} - O(\varepsilon^2)$ and $\lambda^\varepsilon = \Lambda_{\dagger} - O(\varepsilon^4)$ in the cases $I > 0$ and $I = 0$, respectively. We prove that in the case $I < 0$ there are no embedded eigenvalues in the interval $[0, \Lambda_{\dagger}]$, while this interval contains exactly one eigenvalue, if $I \geq 0$. For the justification of these result, the main tools are a reduction to an abstract spectral equation and the use of the max-min-principle.

1. INTRODUCTION

ses@c1

1.1. **Formulation of the problem.** Spectral \blacksquare elliptic problems modelling physical phenomena in unbounded domains nearly always have continuous spectra, which allow wave processes in the related frequency ranges in the physical systems under consideration. The spectrum may also contain eigenvalues embedded in the continuous spectrum. Eigenfunctions corresponding to these eigenvalues have finite energy and usually decay rapidly at infinity, which means that they are localized in a bounded region and for this reason called "trapped modes". Such trapped modes prevent wave propagation and promote the accumulation of energy, and thus are related with interesting physical phenomena. They may be unwanted, as they may cause damage to mechanical structures, or wanted, for example for the design of wave filters and dampers.

The physical system considered in this paper is the linearised water-wave model. We investigate the interaction of water-waves with a thin screen, which is submerged or surface piercing in a cylindrical three dimensional channel. The channel is infinite and invariant along the longitudinal x_1 -direction, moreover, it and the screen are assumed to be mirror symmetric \blacksquare with respect to the transversal x_2 -direction. The wave motion is supposed to take place in an incompressible and inviscid fluid. Our aim is to discuss the existence and uniqueness of an eigenvalue embedded in the continuous spectrum. The main results, Theorems 1.1 and 3.1, state that such an eigenvalue exists depending on the behaviour of a certain integral characteristic $I(h)$

Key words and phrases. linear water wave system, cylindrical channel, Steklov condition, asymptotic analysis, artificial Dirichlet condition, continuous spectrum, embedded eigenvalue.

The second named author was supported by RFFI, grant 18-01-00325 and by the Academy of Finland Project 289706. The third named author was partially supported by grants from the group GNAMPA of INDAM, the Magnus Ehrnrooth Foundation and Väisälä Foundation of the Finnish Academy of Science and Letters.

to be defined later. Indeed, we shall show that, in the case $I(h) < 0$, no eigenvalues exist in the interval $(0, \Lambda_{\dagger})$, where Λ_{\dagger} is a positive, artificial cut-off point, and that for $I(h) \geq 0$ an eigenvalue does exist in $(0, \Lambda_{\dagger})$. However, in the cases $I(h) > 0$ and $I(h) = 0$ the eigenvalues have different asymptotic behaviour. For a sufficiently thin screen an eigenvalue is shown to be unique in $(0, \Lambda_{\dagger})$ so that the inequality $I(h) \geq 0$ becomes a criterion for a trapped mode. The edge of the screen is assumed to be sharp, which simplifies our justification scheme but on the other hand requires an elaborate analysis of singularities of solutions on the edge, see Section 3.3.

The special feature of the linear-water wave equation is the appearance of spectral parameter in the Steklov boundary condition of the free water surface. This makes a direct application of the classical Sobolev-space methods difficult, see for example the review paper [14] and the monograph [13], especially for an approach based on the application of the Dirichlet-to-Neumann-(or Steklov-Poincaré-)operator. We follow here the modified techniques used for example in [18, 25] which are based, among other things, on an unconventional definition of the problem operator with mixed types of inner products containing both volume and surface integrals; see (4.13). This method has been used to proving or disproving the existence of an eigenvalue in some interval, but here we use it, together with a new asymptotic approach, for obtaining precise information on the position of the lowest embedded eigenvalue. (We expect the method will eventually make it possible to find a point with complex resonance, if the symmetry assumed in this paper is broken. However, this study is postponed to a planned forthcoming paper, since it will require new techniques.)

Let us proceed by describing the water domain in detail. We define a cylindrical three dimensional channel (Fig. 1.1.a) by

$$\boxed{1} \quad (1.1) \quad \Pi = \{\mathbf{x} = (x_1, x_2, x_3) = (x_1, \mathbf{x}') : x_1 \in \mathbb{R}, \mathbf{x}' \in \varpi\} = \mathbb{R} \times \varpi,$$

where the cross-section $\varpi \subset \mathbb{R}^2$ is a bounded domain, the boundary $\partial\varpi$ of which consists of the line segment

$$\boxed{2} \quad (1.2) \quad \gamma = \{\mathbf{x}' = (x_2, x_3) : z = x_3 = 0, |x_2| < l\}, \quad l > 0,$$

and of a smooth arc $\varsigma \subset \mathbb{R}_-^2 = \{(x_2, x_3) : x_3 < 0\}$ connecting the points $P^{\pm} = (\pm l, 0)$.

The thin screen Θ^{ε} depending on the small parameter $\varepsilon > 0$ is described as follows. Let $\theta \subset \mathbb{R}^2$ an open subset of $\overline{\varpi}$, such that $P^{\pm} \notin \overline{\theta} = \theta \cup \partial\theta$. Assuming that two, not identically zero profile functions $h_{\pm} \in \mathcal{C}^2(\theta)$ are given such that $h = h_+ + h_- \geq 0$, we define the thin screen, flat screen and the profile boundary, respectively, by

$$\boxed{3} \quad (1.3) \quad \Theta^{\varepsilon} = \{\mathbf{x} : \mathbf{x}' \in \overline{\theta}, -\varepsilon h_-(\mathbf{x}') \leq x_1 \leq \varepsilon h_+(\mathbf{x}')\},$$

$$\boxed{10} \quad (1.4) \quad \Theta^0 = \{\mathbf{x} : \mathbf{x}' \in \overline{\theta}, x_1 = 0\},$$

$$\boxed{4} \quad (1.5) \quad \theta_{\pm}^{\varepsilon} = \{\mathbf{x} : \mathbf{x}' \in \theta, x_1 = \pm \varepsilon h_{\pm}(\mathbf{x}')\}.$$

By rescaling we reduce the characteristic size of the cross section ϖ to one and, therefore, make the Cartesian coordinates x and all geometric parameters dimensionless. ■ For the sake of simplicity we assume that the curve $\psi = \partial\theta \cap \varpi$ is smooth and that ψ and ς both intersect γ at right angle $\alpha = \pi/2$. Note in particular that in this case the boundary is certainly non-cuspidal; ■ cuspidal boundaries, possibly causing non-empty continuous spectra and thus wave processes even in finite volume domains, were studied in [24].

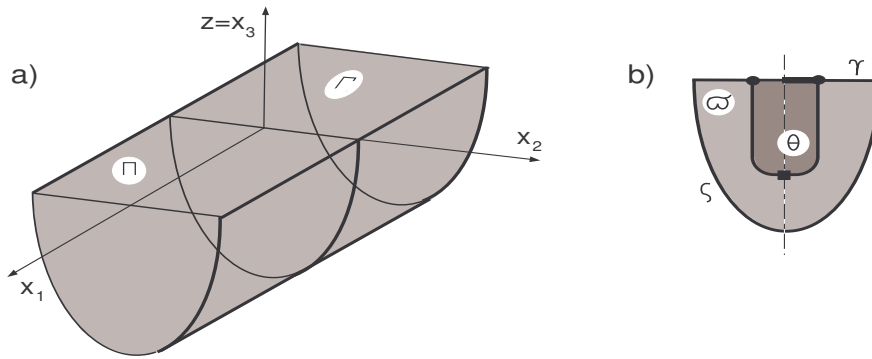

FIGURE 1.1. Three dimensional channel, its two-dimensional cross-section and the projection of the screen onto the cross-section (shaded)

fig1

We denote by $\Omega^\varepsilon = \Pi \setminus \Theta^\varepsilon$, $\varepsilon \geq 0$, the channel (1.1) with the thin or flat vertical screen (1.3), Fig. 1.2.a, and consider the propagation of water-waves along the horizontal free surface

$$\boxed{5} \quad (1.6) \quad \Gamma^\varepsilon = \Gamma \setminus \Theta^\varepsilon,$$

where $\blacksquare \Gamma = \mathbb{R} \times \gamma$ is the intact channel surface. Notice that Γ can be pierced by the screen, but in the case $\partial\theta \cap \gamma = \emptyset$ the obstacle Θ^ε is submerged, and, therefore $\Gamma^\varepsilon = \Gamma$. The bottom and walls $\Sigma = \mathbb{R} \times \zeta$ of the channel Π can be touched by the obstacle, too, and we denote

$$\boxed{6} \quad (1.7) \quad \Sigma^\varepsilon = \Sigma \setminus \Theta^\varepsilon.$$

Our analysis is based on the usual assumptions of the linear water-wave theory: the motion is irrotational and of small amplitude. These assumptions and the incompressibility of the fluid allow us to define a three-dimensional velocity potential, $W^\varepsilon = W^\varepsilon(\mathbf{x}, t)$, which satisfies the Laplace equation in the water domain. On the free surface we impose kinematic and dynamic boundary conditions which, ignoring surface tension, translate to continuity of the normal velocity and the pressure. We take the constant ambient pressure above the free surface to be zero. For small-amplitude waves, it makes sense to consider linearised equations of motion and, assuming that the motion is time harmonic along the cylinder in the x_1 -direction, we thus seek for a velocity potential of the form $W^\varepsilon(\mathbf{x}, t) = \text{Re}(u^\varepsilon(\mathbf{x}) e^{i(kx_1 - \omega^\varepsilon t)})$, where both the radian frequency ω^ε and the wave number k are taken real, say $k > 0$, so that the solution stays bounded for all \mathbf{x} and t . Due to small surface elevations, the boundary condition on the free surface is written at a flat horizontal surface. On substituting W^ε into the linearised equations of motion, we obtain the following equations. For any $\varepsilon > 0$, the velocity potential u^ε satisfies the Laplace equation

$$\boxed{7} \quad (1.8) \quad -\Delta u^\varepsilon(\mathbf{x}) = 0, \quad \mathbf{x} \in \Omega^\varepsilon,$$

the Neumann (no-flow) boundary condition on the wetted surfaces (1.7) and (1.5),

$$\boxed{8} \quad (1.9) \quad \partial_\nu u^\varepsilon(\mathbf{x}) = 0, \quad \mathbf{x} \in \Sigma^\varepsilon \cup \theta_+^\varepsilon \cup \theta_-^\varepsilon,$$

and the kinematic condition on the \blacksquare linearised water surface (1.6)

$$\boxed{9} \quad (1.10) \quad \partial_z u^\varepsilon(\mathbf{x}) = \lambda^\varepsilon u^\varepsilon(\mathbf{x}), \quad \mathbf{x} \in \Gamma^\varepsilon.$$

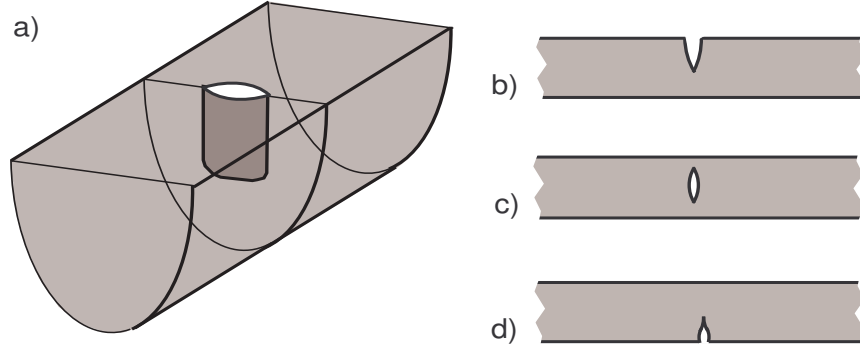

FIGURE 1.2. ■ a) Channel with a thin screen, b) a surface-pearing screen, c) a submerged screen, d) a screen as a protrusion of the bottom.

fig2

We denote the gradient and Laplacian with respect to the variable x by ∇ and Δ , while ∂_z and ∂_ν stand for the partial derivative with respect to $z = x_3$ and the outer unit normal, respectively. Moreover, $\lambda^\varepsilon = g^{-1}(\omega^\varepsilon)^2$ is a spectral parameter, where $g > 0$ is the acceleration of gravity. ■ Since the boundary $\partial\Omega^\varepsilon$ has an edge-type irregularity, we impose the traditional Meixner condition [16], which implies the square integrability of the velocity vector ∇u^ε . This condition is assumed throughout the paper, see Section 3.3.

We make the following assumptions on symmetry and shape of the screen, the role of which will be discussed in Section 1.3.

- 1°. Both ϖ and θ are symmetric with respect to the axis $\{\mathbf{x}' : x_2 = 0\}$.
- 2°. Both profile functions h_\pm in (1.3), (1.5) are even in x_2 .
- 3°. We have $h_\pm(\mathbf{x}') = 0$ for $\mathbf{x}' \in \psi = \partial\theta \setminus \gamma$.

sec1.2

1.2. Main results and plan of the paper. It is known that the spectrum of the problem (1.8)–(1.10) is continuous and coincides with the intact closed positive semi-axis $\overline{\mathbb{R}_+} = [0, +\infty) \subset \mathbb{C}$, see [13]. However, it may contain embedded eigenvalues associated with exponentially decaying eigenfunctions. The main purpose of our paper is to derive and justify an asymptotic formula for such eigenvalues as well as to prove a uniqueness result. To this end we shall use in Section 1.3 the symmetry assumptions 1°–3° to introduce a problem (1.15)–(1.18) with an artificial Dirichlet condition on the symmetry plane. The continuous spectrum of this problem is known to be the interval $[\Lambda_\dagger, +\infty)$, where the threshold Λ_\dagger is positive. In Sections 2 and 3 we construct formal asymptotics for an eigenvalue

$$(23) \quad (1.11) \quad \lambda^\varepsilon = \Lambda_\dagger - \widehat{\lambda}^\varepsilon, \quad \widehat{\lambda}^\varepsilon \rightarrow +0 \text{ as } \varepsilon \rightarrow +0.$$

of the problem (1.15)–(1.18); λ^ε is also an eigenvalue of the problem (1.8)–(1.10).

■ Two different cases with $\widehat{\lambda}^\varepsilon \cong \lambda_0 \varepsilon^2$, (2.1), and $\widehat{\lambda}^\varepsilon \cong \lambda_1 \varepsilon^4$, (3.2), will be found. In Section 2 we introduce an integral characteristic (2.28), denoted by $I(h)$, such that for $I(h) > 0$ the correction term $\widehat{\lambda}^\varepsilon \approx \lambda_0 \varepsilon^2$ is positive, but for $I(h) < 0$ it is not. Accordingly, we formulate the first main result of our paper as follows

NDC

Theorem 1.1. *Assume that the conditions 1°–3° hold true. Then, there exists $\varepsilon_1 = \varepsilon_1(\theta, h_\pm) > 0$ such that*

- 1) if $I(h) < 0$, the problem (1.8)–(1.10) has no eigenvalue in the segment $[0, \Lambda_+]$, when $\varepsilon \in (0, \varepsilon_1]$,
- 2) if $I(h) > 0$, the problem (1.8)–(1.10) has for every $\varepsilon \in (0, \varepsilon_1]$ a unique eigenvalue (1.11) inside the segment $[0, \Lambda_+]$. The coefficient $\lambda_0 > 0$ is given by (2.31), (2.28) and the asymptotic remainder $\tilde{\lambda}^\varepsilon = \lambda^\varepsilon - (\Lambda_+ - \lambda_0 \varepsilon_0^2) = \lambda_0 \varepsilon_0^2 - \hat{\lambda}^\varepsilon$ satisfies the estimate

$$\boxed{59} \quad (1.12) \quad |\tilde{\lambda}^\varepsilon| \leq c_1 \varepsilon^{5/2},$$

where c_1 is independent of the small parameter ε .

The most complicated case $I(h) = 0$ will be examined in Section 3, where \blacksquare a new characteristic $J(h) > 0$, (3.22), as well as the formula $\hat{\lambda}^\varepsilon \approx \lambda_1 \varepsilon^4$ will be derived. The related calculations become much more complicated, and they crucially rely on the assumption $\mathbf{3}^\circ$. The corresponding result is formulated as Theorem 3.1, below.

For the proofs we shall apply asymptotic analysis, which involves rectifying the screen Θ^ε and transferring the Neumann boundary conditions onto the faces of the flat screen Θ^0 . The asymptotic procedure will be justified in the last two sections. In Section 4 we prove uniqueness assertions, namely, we verify that in the case $I(h) < 0$ the interval $(0, \Lambda_+)$ does not contain eigenvalues at all, but in the case $I(h) \geq 0$ the eigenvalue $\lambda^\varepsilon \in (0, \Lambda_+)$ is unique. In Section 5 we show that indeed, the eigenvalue λ^ε exists and has the asymptotic form claimed in Theorems 1.1 and 3.1. Moreover, we give estimates for the asymptotic remainders. All these results are based on the reduction of water-wave problem (1.15)–(1.18) to the abstract spectral equation (4.18) and the application of basic theory of self-adjoint Hilbert space operators, cf. [2, 26].

We finish the paper with several particular conclusions, possible generalisations and open questions.

sec1.3

1.3. Role of symmetry restrictions. The operator theoretic methods, which work efficiently for the discrete spectrum, cannot be directly applied, since the continuous spectrum covers the whole semi-axis $\overline{\mathbb{R}_+} = [0, +\infty)$ and thus the problem (1.8)–(1.10) cannot have isolated eigenvalues. To create an artificial positive cut-off value Λ_+ we borrow an elegant idea [6] of the Dirichlet boundary condition on the midplane of the waveguide Π^ε , for which we need the symmetry assumptions $\mathbf{1}^\circ$, $\mathbf{2}^\circ$. These requirements allow us to restrict the problem (1.8)–(1.10) to the half-channel Ω^ε ,

$$\boxed{11} \quad (1.13) \quad \Omega_r^\varepsilon = \{\mathbf{x} \in \Omega^\varepsilon : x_2 > 0\},$$

and to impose the artificial Dirichlet condition on the middle plane

$$\boxed{12} \quad (1.14) \quad \begin{aligned} \Upsilon^\varepsilon &= \{\mathbf{x} \in \Omega^\varepsilon : x_2 = 0\} = \Upsilon \setminus \Theta^\varepsilon, \\ \Upsilon &= v \times \mathbb{R}, \quad v = \{\mathbf{x}' \in \varpi : x_2 = 0\}. \end{aligned}$$

All objects restricted to the domain (1.13) are supplied with the subscript r so that the new problem reads as

$$\boxed{13} \quad (1.15) \quad -\Delta u^\varepsilon(\mathbf{x}) = 0, \quad \mathbf{x} \in \Omega_r^\varepsilon,$$

$$\boxed{14} \quad (1.16) \quad \partial_\nu u^\varepsilon(\mathbf{x}) = 0, \quad \mathbf{x} \in \Sigma_r \cup \theta_{+,r}^\varepsilon \cup \theta_{-,r}^\varepsilon,$$

$$\boxed{15} \quad (1.17) \quad \partial_z u^\varepsilon(\mathbf{x}) = \lambda_r^\varepsilon u^\varepsilon(\mathbf{x}), \quad \mathbf{x} \in \Gamma_r,$$

$$\boxed{16} \quad (1.18) \quad u^\varepsilon(\mathbf{x}) = 0, \quad \mathbf{x} \in \Upsilon^\varepsilon.$$

■ As motivation for studying this problem with the artificial boundary condition we mention that the continuous spectrum of the problem (1.15)–(1.18) coincides with the ray $[\Lambda_{\dagger}, +\infty)$, where $\Lambda_{\dagger} > 0$ (see below). Hence, there may still exist discrete spectrum of (1.15)–(1.18) contained in the interval $(0, \Lambda_{\dagger})$, and if this happens, one can make an odd, smooth and harmonic extension of a corresponding eigenfunction $u^{\varepsilon} \in H^1(\Omega_r^{\varepsilon}; \Upsilon^{\varepsilon})$ of (1.15)–(1.18), which thus becomes an eigenfunction of the original problem (1.8)–(1.10). This gives us a way to study eigenvalues embedded into the interval $(0, \Lambda_{\dagger})$ of the continuous spectrum. Notice that Λ_{\dagger} is nothing but the first eigenvalue of the model problem on the half ϖ_r of the cross-section ϖ :

$$\boxed{17} \quad (1.19) \quad -\Delta' U(\mathbf{x}') = 0, \quad \mathbf{x}' \in \varpi_r,$$

$$\boxed{18} \quad (1.20) \quad \partial_\nu U(\mathbf{x}') = 0, \quad \mathbf{x}' \in \varsigma_r$$

$$\boxed{19} \quad (1.21) \quad \partial_z U(\mathbf{x}') = \Lambda U(\mathbf{x}'), \quad \mathbf{x}' \in \gamma_r,$$

$$\boxed{20} \quad (1.22) \quad U(\mathbf{x}') = 0, \quad \mathbf{x}' \in v.$$

Here, Δ' is the Laplacian in the coordinates \mathbf{x}' . Due to the Dirichlet condition (1.22), the first eigenvalue $\Lambda = \Lambda_{\dagger}$ is positive and can be computed from the max-min-principle

$$\boxed{21} \quad (1.23) \quad \Lambda_{\dagger} = \inf_V \frac{\|\nabla' V; L^2(\varpi_r)\|^2}{\|V; L^2(\gamma_r)\|^2},$$

where ■ $\|\cdot; L^2(D)\|$ denotes the standard norm of the Lebesgue L^2 -space on a domain D , the infimum is taken over all $V \in H_0^1(\varpi_r, v) \setminus H_0^1(\varpi_r, \gamma_r)$ and $H_0^1(\varpi_r, \omega)$ is the Sobolev space of functions vanishing in the subdomain $\omega \subset \varpi$. According to the strong maximum principle the corresponding eigenfunction U_{\dagger} can be chosen positive in ϖ_r and subject to the normalization condition

$$\boxed{22} \quad (1.24) \quad \int_0^l |U_{\dagger}(x_2, 0)|^2 dx_2 = 1.$$

Since the cut-off value (1.23) is positive, the problem (1.15)–(1.18) may still have non-empty discrete spectrum in the interval $(0, \Lambda_{\dagger})$. Moreover, the odd extension ■ with respect to x_2 of an eigenfunction $u^{\varepsilon} \in H^1(\Omega_r^{\varepsilon}; \Upsilon^{\varepsilon})$ of (1.15)–(1.18) is smooth and harmonic, and therefore it becomes an eigenfunction of the original problem (1.8)–(1.10). In this way, eigenvalues embedded into the interval $(0, \Lambda_{\dagger})$ can be examined using operator theory.

sec1.4 Remark 1.2. It was observed in [20], in connection with a different spectral problem, that the existence of the eigenvalue (1.11) for (1.8)–(1.10) implies that the limit problem corresponding to $\varepsilon = 0$,

$$\boxed{24} \quad (1.25) \quad -\Delta u^0(\mathbf{x}) = 0, \quad \mathbf{x} \in \Omega_r^0 = \Pi_r \setminus \Theta_r^0,$$

$$\boxed{25} \quad (1.26) \quad \partial_\nu u^0(\mathbf{x}) = 0, \quad \mathbf{x} \in \Sigma_r \cup \theta_{+,r}^0 \cup \theta_{-,r}^0$$

$$\boxed{26} \quad (1.27) \quad \partial_z u^0(\mathbf{x}) = \Lambda_{\dagger} u^0(\mathbf{x}), \quad \mathbf{x} \in \Gamma_r,$$

$$\boxed{27} \quad (1.28) \quad u^0(\mathbf{x}) = 0, \quad \mathbf{x} \in \Upsilon^0,$$

■ ■ has a solution, which is stabilizing at infinity (i.e. asymptotically equal to a function depending on \mathbf{x}' only). In our case this stabilizing at infinity-solution can be readily found: it is

$$\boxed{28} \quad (1.29) \quad u^{(0)}(\mathbf{x}) = U_{\dagger}(\mathbf{x}'),$$

where U_{\dagger} is the eigenfunction of (1.19)–(1.22) associated with the eigenvalue Λ_{\dagger} . Indeed, on the surfaces $\theta_{\pm}^0 = \{\mathbf{x} : \mathbf{x}' \in \theta, x_1 = 0\}$ of the flat screen (1.4), the derivative ∂_{ν} equals $\pm \partial_1 = \mp \partial / \partial x_1$, while the standing wave (1.29) does not depend on the longitudinal coordinate x_1 .

sec1.5

1.4. Literature review. The first example of a (non-embedded) eigenvalue belonging to the discrete spectrum of a problem on oblique waves for a submerged circular cylinder was proposed in [27]. An eigenvalue embedded in the continuous spectrum was constructed in [12] by means of the semi-inverse method. The results in these pioneering papers were obtained by analytic calculations, and they have inspired many other publications with analytic, operator theoretic, or numerical methods (see the reviews in [13] and [14]). In particular, the existence of eigenvalues below the continuous spectrum has been verified with the help of a comparison principle in the paper [28], which also extends the results of [27] to a cylinder with an arbitrary cross-section with positive area.

In the paper [18] the existence of an embedded eigenvalue is shown in the cases of a two-dimensional deep water-domain and a three-dimensional channel, which is similar to the one in the present work, but instead of a thin screen contains a massive body as an obstacle. In both cases the problem is assumed to have the geometric symmetry $\mathbf{1}^{\circ}$ – $\mathbf{2}^{\circ}$, which concerns both the water container and the submerged or surface-piercing body. We remark that by the results of [18], an absolutely flat ($h = 0$) transversal screen (1.4) does not support a trapped mode, but its inclination does. More accurate information on the trapping for small inclination angles in the two-dimensional case is obtained in [30] by using asymptotic analysis. The result on the flat screen cannot directly be obtained from [27], [28], because the volume of Θ^{ε} vanishes at $h = 0$.

In comparison with the present work, [18] cannot yield a uniqueness statement or precise information of the position of the embedded eigenvalue λ^{ε} , since it does not include the elaborate asymptotic construction and matching of the outer and inner expansions of the eigenfunction u^{ε} and the resulting asymptotic formulas for λ^{ε} . The approach in the references relies upon a reformulation of the water-wave problem as a self-adjoint operator in a specific Hilbert space and an application of the max-min-principle, see e.g. [2, Thm. 10.2.2.] and [26]. This method has given rather simple proofs of known facts and also new results; the reason is mainly that in certain geometric situations it is possible to construct trial functions, which help to evaluate properly the Rayleigh quotient in the max-min-principle. In this paper, these approximations of eigenvalues and eigenfunctions are made much more precise by perfecting the mentioned method with the help of asymptotic analysis. In Section 6.1 we shall make some further remarks on the relations of [18] and the present work.

In addition to the above described approach of [6], which requires the symmetry conditions $\mathbf{1}^{\circ}$ and $\mathbf{2}^{\circ}$, there exists another method [20, 22] to detect embedded eigenvalues. This is based on the asymptotic analysis of the so-called augmented scattering matrix, which provides a criterion for the existence of trapped modes. This approach does not require the symmetry of the domains ϖ , θ , or the evenness of the profile functions h_{\pm} . Instead, it uses the natural instability of embedded eigenvalues (indeed, their position is sensitive even to small changes of the geometry of the problem domain) and performs a very fine tuning of several geometric parameters of the screen shape in order to keep an eigenvalue in the continuous

spectrum. We emphasize that the embedded eigenvalue λ^ε of this paper (see (2.1), (2.31), (3.2), (3.25)) is stable, when h_\pm are perturbed with functions even in x_2 , but asymmetric perturbations may lead λ^ε out of the spectrum and turn it into a point of complex resonance, cf. [1, 21].

The method of matched asymptotic expansions, cf. [29, 9] will be employed in Sections 2 and 3 by applying the interpretation of [19, 20]. Related asymptotic procedures have also been used in [8, 7, 19, 3, 4] etc. to describe asymptotic behaviour of eigenvalues in cylindrical waveguides with small regular and singular perturbations, but these works differ from the present one, since in our case the obstacle is not small in x_2 - and z -directions.

Methods of asymptotic analysis are also used in the paper [30], which treat problems for two-dimensional water-wave and acoustic waveguides with screens similar to this paper. However, the present work is quite different in several aspects; let us conclude this section by discussing these.

First of all, the flat screen (1.4), which is the defect in the reference waveguide $\Omega^0 = \Pi \setminus \Theta^0$ is still large in the sense that it is not contained in a ball of radius ε , contrary to the previous citation.

As usual, a more simple ansatz and other technical reasons imply that asymptotic analysis is much simpler in dimension 2. This in particular makes it possible in [30] to control the boundary layer terms of the asymptotic ansätze (describing the eigenfunction in the vicinity of the obstacle) for fairly general linear screens. Corresponding boundary layers have not been investigated yet in dimension 3, nor can we present their structure here. Thus, we unfortunately have to accept the restriction $\mathbf{3}^\circ$: this makes the edge of the screen

$$(1.30) \quad \Psi = \{\mathbf{x} : x_1 = 0, \mathbf{x}' \in \psi\}$$

dihedral or cuspidal, see Fig. 1.2.b-d, but it also makes the boundary layer effect to lose its significance. We refer to Section 6.2 of the present paper for a discussion on the boundary layer phenomenon in some special cases and also to [15, Part IV] for particular results.

Second, we deal with screens which pierce the free surface, Fig. 1.2.b, and abut the walls and bottom, Fig. 1.2.d, while in [30] the screen is situated inside the channel, Fig. 1.2.c. Note that in the case of a surface-piercing screen Θ^ε we are able to single out shapes, which do not support trapped modes for any $\lambda^\varepsilon \in (0, \Lambda_\dagger)$, while screens which always trap a wave are outlined in Fig. 1.2.c,d.

Third, although the sharp edge (1.30) of the screen causes singular behaviour of the velocity potential u^ε , the assumption $\mathbf{3}^\circ$ enables the use of asymptotic methods generated by regular perturbations of the boundary.

Finally, we shall find two different types of asymptotic expansions of the eigenvalue (1.11), which depend on some integral characteristics of the screen and which are in full agreement with the sufficient condition for the existence of trapped modes, see Section 6.1. In this way the sufficient condition of [18] becomes also a necessary one for a small ε .

2. ASYMPTOTIC ANALYSIS. NON-DEGENERATE CASE

ses2c2

2.1. Outer expansions. In this section we propose an asymptotic representation for an eigenvalue λ^ε of (1.15)–(1.18) under the assumption that the integral characteristic $I(h)$, (2.28), below, does not vanish. We shall establish the asymptotic

representation

$$\boxed{31} \quad (2.1) \quad \lambda^\varepsilon = \Lambda_\dagger - \varepsilon^2 \lambda_0 + \tilde{\lambda}^\varepsilon,$$

and find a sufficient condition for the crucial property $\lambda_0 > 0$ (see Theorem 1.1). The estimate $|\tilde{\lambda}^\varepsilon| \leq c_1 \varepsilon^{5/2}$ for the remainder will be obtained in Section 5.4.

■ We assume the following asymptotic ansatz for a trapped wave:

$$\boxed{32} \quad (2.2) \quad u^\varepsilon(\mathbf{x}) = c_\pm(\varepsilon) e^{\mp \mu(\varepsilon) x_1} V(\varepsilon; \mathbf{x}') + \dots, \quad \pm x_1 \gg 1.$$

This involves exponential waves in the intact channel (1.1) at the spectral parameter (2.1), while the screen effects the expansion only through the coefficients c_\pm , which have the Taylor expansion $c_\pm(\varepsilon) = c_\pm(0) + \varepsilon c'_\pm(0) + O(\varepsilon^2)$. The dots in (2.2) stand for higher order terms, and the couple $\{\mu(\varepsilon), V(\varepsilon; \mathbf{x}')\}$ is a solution of the following problem in a two-dimensional domain,

$$\boxed{33} \quad (2.3) \quad \begin{aligned} -\Delta' V(\varepsilon; \mathbf{x}') &= \mu(\varepsilon)^2 V(\varepsilon; \mathbf{x}'), & \mathbf{x}' \in \varpi_r, \\ \partial_\nu V(\varepsilon; \mathbf{x}') &= 0, & \mathbf{x}' \in \varsigma_r, \quad V(\varepsilon; \mathbf{x}') = 0, & \mathbf{x}' \in \nu, \\ \partial_z V(\varepsilon; \mathbf{x}') &= \lambda^\varepsilon V(\varepsilon; \mathbf{x}'), & \mathbf{x}' \in \gamma_r. \end{aligned}$$

Perturbation theory of linear operators, see e.g. [10, Ch. 6], yields the representations

$$\boxed{34} \quad (2.4) \quad \mu(\varepsilon) = 0 + \varepsilon \mu_0 + \tilde{\mu}(\varepsilon), \quad V(\varepsilon; \mathbf{x}') = U_\dagger(\mathbf{x}') + \varepsilon^2 V_0(\mathbf{x}') + \tilde{V}(\varepsilon; \mathbf{x}')$$

(U_\dagger as in (1.24)) the following problem for the correction terms in (2.4),

$$\boxed{35} \quad (2.5) \quad -\Delta' V_0(\mathbf{x}') = \mu_0^2 U_\dagger(\mathbf{x}'), \quad \mathbf{x}' \in \varpi_r,$$

$$\boxed{36} \quad (2.6) \quad \partial_\nu V_0(\mathbf{x}') = 0, \quad \mathbf{x}' \in \varsigma_r, \quad V_0(\mathbf{x}') = 0, \quad \mathbf{x}' \in \nu,$$

$$\boxed{37} \quad (2.7) \quad \partial_z V_0(\mathbf{x}') = \Lambda_\dagger V_0(\mathbf{x}') - \lambda_0 U_\dagger(\mathbf{x}'), \quad \mathbf{x}' \in \gamma_r,$$

as well as the error estimates

$$\boxed{38} \quad (2.8) \quad |\tilde{\mu}(\varepsilon)| \leq c\varepsilon^2, \quad \|\tilde{V}(\varepsilon, \cdot); H^1(\varpi_r)\| \leq c\varepsilon^3.$$

We mention that (2.3) is obtained by inserting the exponential waves $e^{\pm \mu(\varepsilon) x_1} V(\varepsilon, \mathbf{x}')$ into the problem (1.15)–(1.18), while (2.5)–(2.7) follows by substituting (2.1), (2.4) into (2.3) and extracting terms of order ε^2 .

Since Λ_\dagger is a simple eigenvalue of the ■ model problem (1.19)–(1.22) in ϖ_r , the Fredholm alternative yields only one compatibility condition, which by the Green formula turns into

$$\begin{aligned} \mu_0^2 \int_{\varpi_r} |U_\dagger(\mathbf{x}')|^2 d\mathbf{x}' &= - \int_{\varpi_r} (U_\dagger(\mathbf{x}') \Delta' V_0(\mathbf{x}') - V_0(\mathbf{x}') \Delta' U_\dagger(\mathbf{x}')) d\mathbf{x}' \\ &= \int_{\partial \varpi_r} (V_0(\mathbf{x}') \partial_\nu U_\dagger(\mathbf{x}') - U_\dagger(\mathbf{x}') \partial_\nu V_0(\mathbf{x}')) ds_{\mathbf{x}'} = \lambda_0 \int_0^l |U_\dagger(x_2, 0)|^2 dx_2. \end{aligned}$$

This was obtained by taking into account the differential equations (1.19) and (2.5) as well as the boundary conditions (1.20)–(1.22) and (2.6), (2.7). Moreover, according to the normalization condition (1.24) we have

$$\boxed{39} \quad (2.9) \quad \mu_0 = \|U_\dagger; L^2(\varpi_r)\|^{-1} \lambda_0^{1/2}.$$

As a consequence, the outer expansions (2.2) looks as follows:

$$\boxed{40} \quad (2.10) \quad u^\varepsilon(\mathbf{x}) = c_\pm(0) U_\dagger(\mathbf{x}') + \varepsilon (c'_\pm(0) U_\dagger(\mathbf{x}') \mp c_\pm(0) \mu_0 x_1 U_\dagger(\mathbf{x}')) + \dots, \quad \pm x_1 \gg 1.$$

sec2.2

2.2. Inner expansion. In a bounded part of the channel Ω_r^ε , e.g. near the screen Θ_r^ε , we can take a traditional expansion for a trapped mode:

$$(2.11) \quad u^\varepsilon(\mathbf{x}) = v_0(\mathbf{x}) + \varepsilon v_1(\mathbf{x}) + \dots ,$$

where the dots indicate terms of order at most $O(\varepsilon^2)$. The matching procedure, cf. [29, 9, 19, 20], requires that the behaviour of $v_0(\mathbf{x})$ and $v_1(\mathbf{x})$ as $x_1 \rightarrow \pm\infty$ is given by the similar terms in (2.10). Thus, as the first step we notice that v_0 behaves at infinity as the standing wave U_\dagger , that is,

$$v_0(\mathbf{x}) = c_\pm(0)U_\dagger(\mathbf{x}') + \dots \text{ for } x_1 \rightarrow \pm\infty.$$

Recalling the solution (1.29) of the limit problem (1.25)–(1.28), we have to set

$$(2.12) \quad c_\pm(0) = 1 \text{ and } v_0(\mathbf{x}) = U_\dagger(\mathbf{x}').$$

To derive a problem for the correction term v_1 in (2.11) we first observe that passing to the limit $\varepsilon \rightarrow 0^+$ flattens the curved screen Θ^ε into the planar one Θ^0 , cf. formulas (1.3) and (1.4). Hence, the equation (1.15) in Ω and the Neumann condition (1.16) on Σ_r^ε yield

$$(2.13) \quad -\Delta v_1(\mathbf{x}) = 0, \quad \mathbf{x} \in \Omega,$$

$$(2.14) \quad -\partial_\nu v_1(\mathbf{x}) = 0, \quad \mathbf{x} \in \Sigma_r^0,$$

In the same way, the artificial Dirichlet condition (1.18) turns into

$$(2.15) \quad v_1(\mathbf{x}) = 0, \quad \mathbf{x} \in \Upsilon^0,$$

while the spectral condition (1.17) gains the threshold parameter because of the relation $\lambda^\varepsilon = \Lambda_\dagger + O(\varepsilon^2)$, so that

$$(2.16) \quad -\partial_\nu v_1(\mathbf{x}) = \Lambda_\dagger v_1(\mathbf{x}), \quad \mathbf{x} \in \Gamma_r^0,$$

It remains to transfer the Neumann condition (1.16) from the curved surfaces $\theta_{\pm,r}^\varepsilon$ onto the flat ones $\theta_{\pm,r}^0$. To do so, we recall definition (1.3) and write the representation

$$\nu_\pm^\varepsilon(\mathbf{x}') = (1 + \varepsilon|\nabla' h_\pm(\mathbf{x}')|)^{-1/2} (\pm 1, \varepsilon \nabla' h_\pm(\mathbf{x}'))$$

for the unit normal vector. Hence,

$$(2.17) \quad (1 + \varepsilon^2|\nabla' h_\pm(\mathbf{x}')|^2)^{1/2} \partial_{\nu_\pm^\varepsilon} = \mp \partial_1 + \varepsilon \nabla' h_\pm(\mathbf{x}') \cdot \nabla',$$

where $\nabla' = (\partial_2, \partial_3)$, $\partial_j = \partial/\partial x_j$ and the central dot stands for the scalar product in \mathbb{R}^2 . This and the Taylor formula with respect to x_1 yield

$$(2.18) \quad \begin{aligned} & (1 + \varepsilon^2|\nabla' h_\pm(\mathbf{x}')|^2)^{1/2} \partial_{\nu_\pm^\varepsilon} v(\pm \varepsilon h_\pm(\mathbf{x}'), \mathbf{x}') \\ &= \pm \partial_1 v(\pm \varepsilon h_\pm(\mathbf{x}'), \mathbf{x}') + \varepsilon \nabla' h(\mathbf{x}') \cdot v(\pm \varepsilon h_\pm(\mathbf{x}'), \mathbf{x}') \\ &= \pm \partial_1 v(\pm 0, \mathbf{x}') - \varepsilon h_\pm(\mathbf{x}') \partial_1^2 v(\pm 0, \mathbf{x}') \\ & \quad + \varepsilon \nabla' h_\pm(\mathbf{x}') \cdot \nabla' v(\pm 0, \mathbf{x}') + \dots, \quad \mathbf{x}' \in \theta. \end{aligned}$$

Finally, inserting (2.11), (2.12) into (2.18) and extracting terms $O(\varepsilon)$ yield the following Neumann conditions on the faces $\theta_{\pm,r}^0$ of the planar screen Θ_r^0 :

$$(2.19) \quad \mp \partial_1 v_1(\pm 0, \mathbf{x}') = -\nabla' h_\pm(\mathbf{x}') \cdot \nabla' U_\dagger(\mathbf{x}'), \quad \mathbf{x}' \in \theta_r.$$

sec2.3

2.3. Solutions of the limit problem at threshold and the matching procedure. As ■ mentioned in the beginning of Section 2.2, the behaviour of the correction term $v_1(\mathbf{x})$ as $x_1 \rightarrow \pm\infty$ in the inner expansion (2.11) is to be matched with the coefficients of ε in the outer expansion (2.10). Thus, we need a solution v_1 of (2.13)–(2.16), (2.19) with linear growth at infinity. We shall next find this and then perform the matching, which will yield a formula for the number λ_0 in (2.1).

To construct v_1 we observe that in addition to the solution (1.29) (even in x_1), the limit problem (1.25)–(1.28) in Ω_r^0 has a solution, which is odd in x_1 and has the representation

$$50 \quad (2.20) \quad u^{(1)}(\mathbf{x}) = \tilde{u}^{(1)}(\mathbf{x}) + \sum_{\pm} \chi_{\pm}(x_1)(x_1 \pm b)U_{\dagger}(\mathbf{x}'),$$

where the remainder $\tilde{u}^{(1)}(\mathbf{x})$ decays exponentially as $x_1 \rightarrow \pm\infty$, b is a constant depending on ϖ , θ , and χ_{\pm} are smooth cut-off functions such that

$$500 \quad (2.21) \quad \chi_{\pm}(x_1) = 1 \text{ for } \pm x_1 > 2, \quad \chi_{\pm}(x_1) = 0 \text{ for } \pm x_1 < 1, \quad 0 \leq \chi_{\pm} \leq 1.$$

There are no other solutions with at most polynomial growth at infinity. ■ These facts follow from general results of the elliptic theory in domains with cylindrical outlets to infinity, see e.g. [23, Ch. 5]. They can also be obtained using the Fourier method by reducing the problem (1.25)–(1.28) to the quarter

$$51 \quad (2.22) \quad \Pi_{r,+} = \{\mathbf{x} \in \Pi : x_1 > 0, x_2 > 0\}$$

of Π and imposing either the Neumann condition (even case) or the Dirichlet condition (odd case) on the subset $\{\mathbf{x} : x_1 = 0, \mathbf{x}' \in \varpi_r \setminus \bar{\theta}_r\}$ of the end of the semi-infinite cylinder (2.22).

By similar arguments we can find out that the problem (2.13)–(2.16), (2.19) in Ω has a solution v_1 with linear growth at infinity. Since it is only defined up to a linear combination $c_0 u^{(0)} + c_1 u^{(1)}$, we may choose the coefficients c_0, c_1 such that

$$52 \quad (2.23) \quad v_1(\mathbf{x}) = \tilde{v}_1(\mathbf{x}) + \sum_{\pm} \chi_{\pm}(x_1)(b_1^1|x_1| \pm b_1^0)U_{\dagger}(\mathbf{x}'),$$

see (1.29), (2.20). The remainder $\tilde{v}_1(\mathbf{x})$ decays exponentially and the coefficients b_1^1, b_1^0 are now uniquely defined. We do not need an explicit expression for b_1^0 , and ■ concerning this coefficient we thus only note that in the special case $h_+ = h_-$ in (2.19), the function (2.23) is even in x_1 and therefore $b_1^0 = 0$.

Let us compute b_1^1 . We insert v_1 and $u^{(0)}$ into the Green formula on the truncated channel $\Omega_r^0(R) = \{\mathbf{x} \in \Omega_r : |x_1| < R\}$ and obtain, ■ recalling that $h = h_+ + h_-$,

$$53 \quad (2.24) \quad \begin{aligned} 0 &= \int_{\partial\Omega_r^0(R)} (U_{\dagger}(\mathbf{x}')\partial_{\nu}v_1(\mathbf{x}) - v_1(\mathbf{x})\partial_{\nu}U_{\dagger}(\mathbf{x}'))ds_x \\ &= \sum_{\pm} - \int_{\theta_r} U_{\dagger}(\mathbf{x}')\nabla'h_{\pm}(\mathbf{x}') \cdot \nabla'U_{\dagger}(\mathbf{x}')d\mathbf{x}' + \sum_{\pm} \pm \int_{\varpi_r} U_{\dagger}(\mathbf{x}')\partial_{\nu}v_1(\pm R, \mathbf{x}')d\mathbf{x}' \\ &= - \int_{\theta_r} U_{\dagger}(\mathbf{x}')\nabla'h(\mathbf{x}') \cdot \nabla'U_{\dagger}(\mathbf{x}')d\mathbf{x}' + 2b_1^1 \int_{\varpi_r} |U_{\dagger}(\mathbf{x}')|^2d\mathbf{x}' + o(1) \end{aligned}$$

as $R \rightarrow +\infty$. Here we have used the boundary conditions on $\partial\Omega_r^0$, in particular (2.19), and the asymptotic expansion (2.23) at $x_1 = \pm R$. Passing to the limit

$R \rightarrow +\infty$ in (2.24) yields

$$\boxed{54} \quad (2.25) \quad b_1^1 = -\frac{1}{2} \|U_{\dagger}; L^2(\varpi_r)\|^{-2} I(h),$$

where we have after integration by parts

$$\boxed{567} \quad (2.26) \quad \begin{aligned} I(h) = & \int_{\theta_r} h(\mathbf{x}') U_{\dagger}(\mathbf{x}') \Delta' U_{\dagger}(\mathbf{x}') d\mathbf{x}' + \int_{\theta_r} h(\mathbf{x}') |\nabla' U_{\dagger}(\mathbf{x}')|^2 d\mathbf{x}' \\ & - \int_{\partial\theta_r} h(\mathbf{x}') U_{\dagger}(\mathbf{x}') \partial_{\nu} U_{\dagger}(\mathbf{x}') ds_{\mathbf{x}'}. \end{aligned}$$

The first integral on the right vanishes due to (1.19), and our assumption $\mathbf{3}^{\circ}$ reduces the last term to an integral over the set \blacksquare

$$\boxed{55} \quad (2.27) \quad \phi_r = \gamma_r \cap \partial\theta_r$$

(the bold segment in Fig. 1.1.b), where $\partial_{\nu} U_{\dagger} = \partial_z U_{\dagger} = \Lambda_{\dagger} U_{\dagger}$ according to (1.21). Thus, \blacksquare

$$\boxed{56} \quad (2.28) \quad I(h) = \int_{\theta_r} h(\mathbf{x}') |\nabla' U_{\dagger}(\mathbf{x}')|^2 d\mathbf{x}' - \Lambda_{\dagger} \int_{\phi_r} h(\mathbf{x}') |U_{\dagger}(\mathbf{x}')|^2 dx_2.$$

Notice that $I(h) > 0$ for sure, if h does not vanish identically and the set (2.27) is empty, i.e., the screen is submerged.

Finally, we match the behaviour of the correction term $v_1(\mathbf{x})$ as $x_1 \rightarrow \pm\infty$ in the inner expansion (2.11) with the coefficients of ε in the outer expansion. Comparing the linear functions in (2.10) and (2.23) we see that

$$\boxed{68} \quad (2.29) \quad \mp \mu_0 = \pm b_1^1 \quad \text{and} \quad c'_{\pm}(0) = \pm b_1^0,$$

\blacksquare where $\mu_0 > 0$ is taken from (2.9). Hence, the relations (2.9) and (2.25) lead us to the formula

$$\boxed{57} \quad (2.30) \quad \|U_{\dagger}; L^2(\varpi_r)\|^{-1} \lambda_0^{1/2} = \mu_0 = -b_1^1 = \frac{1}{2} \|U_{\dagger}; L^2(\varpi_r)\|^{-2} I(h).$$

\blacksquare This can hold true with a nonzero b_1^1 only, if $I(h) > 0$, and in this case we have

$$\boxed{58} \quad (2.31) \quad \lambda_0 = \frac{1}{4} \|U_{\dagger}; L^2(\varpi_r)\|^{-2} I(h)^2.$$

Moreover, if $I(h) < 0$, (2.30) implies that λ_0 cannot be positive. Formula (2.31) for λ_0 completes the formulation of Theorem 1.1; its proof will be completed in Sections 4 and 5.

The degenerate case $I(h) = 0$ will be considered in the next section.

3. ASYMPTOTIC ANALYSIS. DEGENERATE CASE.

§§§§§

3.1. Modified asymptotic ansätze. Next \blacksquare we perform the asymptotic analysis in the case the integral characteristic used in the previous section vanishes. Precisely, we assume that $I(h) = 0$ in Sections 3.1–3.2 and 3.4, although this assumption is relieved in the discussion of Section 3.3. Consequently, the leading correction term in the asymptotic ansatz (2.1) for the eigenvalue λ^{ε} vanishes, since by (2.25), (2.29), and (2.9), we get

$$\boxed{60} \quad (3.1) \quad b_1^1 = 0 \quad \text{and} \quad \lambda_0 = 0, \mu_0 = 0.$$

The linear growth of the solution (2.23) of the problem (2.13)–(2.16), (2.19) is lost and thus the matching, performed in the last section, fails. As we still want to ensure the inclusion $\lambda^\varepsilon \in (0, \Lambda_\dagger)$, we amend the ansatz (2.1) by setting

$$\boxed{61} \quad (3.2) \quad \lambda^\varepsilon = \Lambda_\dagger - \varepsilon^4 \lambda_1 + \tilde{\lambda}^\varepsilon, \lambda_1 > 0.$$

We also have to modify the ansätze (2.4) as follows:

$$\boxed{62} \quad (3.3) \quad \mu(\varepsilon) = 0 + \varepsilon^2 \mu_1 + \tilde{\mu}(\varepsilon), \quad V(\varepsilon, \mathbf{x}') = U_\dagger(\mathbf{x}') + \varepsilon^4 V_1(\mathbf{x}') + \tilde{V}(\varepsilon; \mathbf{x}')$$

Accordingly, estimates (2.8) must turn into

$$\boxed{63} \quad (3.4) \quad |\tilde{\mu}(\varepsilon)| \leq c\varepsilon^4, \quad \|\tilde{V}(\varepsilon, \cdot); H^1(\varpi_r)\| \leq c\varepsilon^6.$$

The pair $\{\mu_1, V_1\}$ in (3.3) satisfies the problem (2.5)–(2.7), which is again derived from (2.9) with evident changes. The compatibility condition in this problem is converted into the relation

$$\boxed{64} \quad (3.5) \quad \mu_1 = \|U_\dagger; L^2(\varpi_r)\|^{-1} \lambda_1^{1/2}.$$

Finally, applying the above mentioned modifications to the outer expansions (2.2) results into the following ansatz,

$$\boxed{65} \quad (3.6) \quad u_0^\varepsilon = c_\pm(0)U_\dagger(\mathbf{x}') + \varepsilon c'_\pm(0)U_\dagger(\mathbf{x}') + \varepsilon^2(c''_\pm(0)U_\dagger(\mathbf{x}') \mp c_\pm(0)\mu_1 x_1 U_\dagger(\mathbf{x}')) + \dots, \quad \pm x_1 \gg 1.$$

Then, the inner expansion (2.11) becomes

$$\boxed{66} \quad (3.7) \quad u_0^\varepsilon(\mathbf{x}) = v_0(\mathbf{x}) + \varepsilon v_1(\mathbf{x}) + \varepsilon^2 v_2(\mathbf{x}) + \dots$$

sec3.2

3.2. First asymptotic terms. Let \blacksquare us derive formulæ for the terms v_1 and v_2 in (3.7). The equations (2.12) still hold, and they can be obtained in the same way as in Section 2.2. Moreover, as was noticed in (3.7), the coefficient (2.25) in the decomposition (2.23) vanishes so that the function v_1 is reduced to

$$\boxed{67} \quad (3.8) \quad v_1(\mathbf{x}) = \tilde{v}_1(\mathbf{x}) + \sum_{\pm} \pm \chi_{\pm}(x_1) b_1^0 U_\dagger(\mathbf{x}').$$

Matching the multiplier of ε in (3.6) with with the corresponding term in (3.8) gives the second relation in (2.29).

Let us compose a boundary value problem in Ω_r^ε for the term v_2 in (3.7). Of course this function satisfies the differential equation (2.13) and the boundary conditions (2.14)–(2.16), when the subscripts are changed from 1 to 2. To derive the boundary conditions on the faces $\theta_{\pm,r}^0$, we refine the decomposition (2.18) and write

$$\begin{aligned} & (1 + \varepsilon^2 |\nabla' h_\pm(\mathbf{x}')|^2)^{1/2} \partial_{\nu_\pm^\varepsilon} (v_0(\mathbf{x}') + \varepsilon v_1(\pm \varepsilon h_\pm(\mathbf{x}'), \mathbf{x}') + \varepsilon^2 v_2(\pm \varepsilon h_\pm(\mathbf{x}'), \mathbf{x}')) \\ & = 0 + \varepsilon (\pm \partial_1 v_1(\pm 0, \mathbf{x}') + \nabla' h(\mathbf{x}') \cdot \nabla' v_0(\mathbf{x}')) \\ \boxed{69} \quad (3.9) \quad & + \varepsilon^2 (\pm \partial_1 v_2(\pm 0, \mathbf{x}') + \nabla' h_\pm(\mathbf{x}') \cdot \nabla' v_1(\pm 0, \mathbf{x}') - h_\pm(\mathbf{x}') \partial_1^2 v_1(\pm 0, \mathbf{x}')) + \dots; \end{aligned}$$

the desired boundary condition for v_2 follows from the requirement that in (3.9), terms of order $O(\varepsilon^2)$ or larger must vanish. Since the coefficient of ε is null due to (2.19), it is enough to annul the coefficient of ε^2 in (3.9) by imposing the Neumann conditions

$$\begin{aligned} & \pm \partial_1 v_2(\pm 0, \mathbf{x}') = -\nabla' h_\pm(\mathbf{x}') \cdot \nabla' v_1(\pm 0, \mathbf{x}') - h_\pm(\mathbf{x}') \Delta' v_1(\pm 0, \mathbf{x}') \\ \boxed{70} \quad (3.10) \quad & = -\nabla' \cdot (h_\pm(\mathbf{x}') \nabla' v_1(\pm 0, \mathbf{x}')), \quad \mathbf{x}' \in \theta_r. \end{aligned}$$

Thus, the function v_2 is determined from the problem (2.13), (2.14)–(2.16) (with the above mentioned change of the index), and (3.10).

sec3.3

3.3. Properties of the singularities of the solutions. The boundary value problems under consideration have been posed on domains with corner points and edges, which may cause singular behaviour for their solutions. Actually, some of our geometric assumptions in Section 1 were made in order to reduce the influence of the singularities to the asymptotic procedure.

First of all we mention that the eigenfunction U_{\dagger} of the problem (1.19)–(1.22) is infinitely differentiable everywhere in $\overline{\omega_r}$, because the arc ς_r is smooth and meets the x_2 - and x_3 -axis at the right angle. A reason for the exclusion of the singularities can be found, e.g., in [23, § 2.4].

The behaviour of the solution v_1 of the problem (2.13)–(2.16), (2.19) near the edge Ψ_r of the screen Θ_r may be quite complicated because of the endpoints of the arc ψ_r , which are tops of polyhedral angles. As known e.g. by [23, Ch. 10, Ch. 11], the behaviour of v_1 in the interior of Ψ is determined by the functions

$$\text{S1} \quad (3.11) \quad K_j(s)r^{j/2} \cos(j\varphi/2), \quad j = 0, 1, 2, \dots,$$

where $s \in (0, L)$ is the arc length along ψ such that $s = 0$ and $s = L$ correspond to the tops of the polyhedral angles, and $(r, \varphi) \in \mathbb{R}_+ \times (0, 2\pi)$ is the polar coordinate system in planes, which are perpendicular to Ψ . The function (3.11) with $j = 0$ is smooth so that the main singularities of the derivatives of v_1 are produced by $K_1(s)r^{1/2} \cos(\varphi/2)$. The coefficient function K_1 is called the intensity factor in the mechanics of solids, and since the data (the right hand side and the curve $\partial\theta$) in (2.19) is infinitely differentiable, it belongs to $C^\infty(0, L)$. However, K_1 may become singular at the tops $s = 0$ and $s = L$ of the polyhedral angles.

As for the point $s = 0$, which is marked by \blacksquare in Fig. 1.1.b, the function K_1 is smooth there, since v_1 can be extended as an odd function with respect to x_2 from Ω_r^0 onto Ω^0 (recall the artificial Dirichlet condition): such an extension preserves the differentiability properties of the data and renders the point in the middle of the smooth edge Ψ . However, K_1 may be only Hölder-continuous at the point $s = L$ which is marked by \bullet in Fig. 1.1.b; that is, $K_1 \in C^{0,\delta}[0, L]$ for any $\delta \in (0, 1)$, while

$$\text{S2} \quad (3.12) \quad |\partial_s^p K_1(s)| \leq C(L - s)^{1-p}, \quad p = 0, 1, 2, \dots$$

Let us explain this last fact. According to the general procedure, e.g. [23, Ch. 10, Ch. 11], the asymptotic expansion of v_1 near the endpoint of $s = L$ of the edge Ψ includes the power-law solutions

$$\text{S3} \quad (3.13) \quad \varrho^\beta \phi(\vartheta)$$

of the Laplace-Neumann problem in the polyhedron \mathbb{K} , which is the complement of the quadrant $\{\mathbf{x} : x_1 = 0, x_2 > x_2^0, x_3 < 0\}$ in the lower half-space. In (3.13), (ϱ, ϑ) are the polar coordinates, β is a real number specified below, and ϕ is a function in the lower hemisphere without half of the meridian, Fig. 3.1.b. We extend this model problem evenly with respect to x_1 through the horizontal plane, and this turns it into the Neumann problem in the domain, which is the full space \mathbb{R}^3 with unbounded incision of the shape of the half-plane. The power-law solutions (3.13) with non-negative exponents β of this problem look like

$$\text{S4} \quad (3.14) \quad \varrho^{k/2} \phi_k(\vartheta) = r^{k/2} \cos(\pi k/2), \quad k = 0, 1, 2, \dots,$$

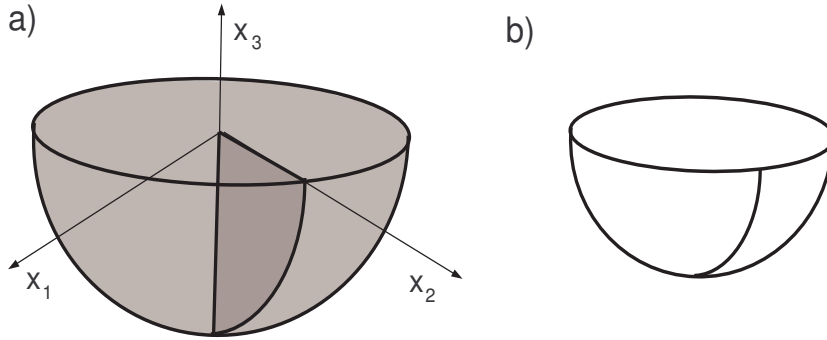

FIGURE 3.1. Hemisphere with incision.

fig3

cf. (3.11). In this way the extension turns the endpoint $s = L$ into an interior point of a smooth edge. At the same time the Neumann boundary condition on the plane $\{\mathbf{x} : z = 0\}$ (the horizontal one in Fig. 3.1.a) was obtained by neglecting the term $\Lambda_+ v_1$ in the Steklov condition (2.16). Thus, there emerges a discrepancy, the main term of which is $\Lambda_+ K_1(L) r^{1/2} \cos(\varphi/2)$, and this has to be compensated by a solution of the following model problem in \mathbb{K} :

$$\begin{aligned} & \varrho^{3/2} (C_0 \phi_3(\vartheta) \ln \varrho + \phi_3'(\vartheta)) \\ \text{[S5]} \quad (3.15) \quad & = \frac{1}{2} C_0 r^{3/2} \ln(r^2 + z^2) \cos\left(\frac{3}{2}\varphi\right) + (r^2 + z^2)^{3/4} \phi_3'(\vartheta). \end{aligned}$$

The first term on the right (with $\cos(3\varphi/2)$) does not affect the singularity of (3.11) (which is $\cos(\varphi/2)$ anyway), but the second term may cause a peculiar behaviour of $K_1(s)$ as $s \rightarrow L - 0$, and this is apparent in the estimates (3.12).

The asymptotic expansion of v_1 could be studied further, in particular it would be possible to verify that the derivative $\partial_s K_1$ is Hölder continuous. However, this would require a much more elaborate analysis, while the information contained in (3.12) suffices in order to conclude that the problem (2.13)–(2.16), (3.10) has a solution which belongs to $H^1(\Omega_r^0(R))$ for any $R > 0$. The inclusion $v_2 \in H_{\text{loc}}^1(\Omega_r^0)$ is obtained from the Hardy-type inequality

$$\text{[S6]} \quad (3.16) \quad \int_{\theta_{\pm,r}^0} r^{-1} (1 + |\ln r|)^{-2} |w(0, \mathbf{x}')|^2 d\mathbf{x}' \leq c \int_{\Omega_r^0(R)} (|\nabla w(\mathbf{x})|^2 + |w(\mathbf{x})|^2) dx,$$

and the weak formulation of the problem in a weighted space with detached asymptotics, cf. [23, Ch. 6]. Instead of using these involved techniques one may directly observe that the right hand sides $g_{\pm}(\mathbf{x}')$ in (3.10) satisfy the bound $|g_{\pm}(\mathbf{x}')| \leq cr^{-1/2}(1 + r/\varrho)$ as a consequence of the assumption **3**^o.

We shall return to a discussion on the singularities in Section 6.3 and now finalize our consideration by writing down the following expansion near the edge:

$$\text{[S7]} \quad (3.17) \quad v_1(\mathbf{x}) = \widehat{v}_1(\mathbf{x}) + K_0(s) + K_1(s) r^{1/2} \cos(\varphi/2).$$

Here, $K_0 \in C^\infty[0, L]$, K_1 belongs to $C^\infty[0, L)$ and satisfies (3.12), and the remainder satisfies the estimates

$$\begin{aligned} & r^{-1} |\widehat{v}_1(\mathbf{x})| + |\nabla \widehat{v}_1(\mathbf{x})| \leq C, \\ \text{[S8]} \quad (3.18) \quad & |\nabla^p \widehat{v}_1(\mathbf{x})| \leq cr^{-p+3/2} (1 + |\ln(L-s)|), \quad p = 2, 3, \dots \end{aligned}$$

for small $r > 0$. Notice that the first of these estimates follow from the smooth term $K_2(s)r^1 \cos(\varphi)$, see (3.11) with $j = 2$, but the last one indicates the singularities $K_3(s)r^{3/2} \cos(3\varphi/2)$ and (3.15). We emphasize that the singularities in (3.17) and (3.18) satisfy the traditional Meixner condition [16] mentioned in Section 1.1.

sec3.4

3.4. Asymptotics of v_2 at infinity. We ■ next apply the approach of Section 2.3 to find the term of v_2 with linear growth as $x_1 \rightarrow \pm\infty$. Indeed, the determining problem for the function v_2 , i.e. (2.13)–(2.16), (3.10), is the same as that for v_1 except for the last boundary condition, which is (2.19) for v_1 instead of (3.10) for v_2 . However, the right hand sides of these two conditions differ only in the compact set θ_r , and we can conclude that v_2 admits the same representation (2.23) as v_1 :

$$(71) \quad (3.19) \quad v_2(\mathbf{x}) = \tilde{v}_2(\mathbf{x}) + \sum_{\pm} \chi_{\pm}(x_1) (b_2^1 |x_1| \pm b_2^0) U_{\dagger}(\mathbf{x}').$$

Let us compute the coefficient b_2^1 . Using integration by parts inside $\Omega_r^0(R)$ and along $\theta_{\pm,r}^0$ we obtain, similarly to (1.12),

$$(72) \quad (3.20) \quad \begin{aligned} 2b_2^1 \int_{\varpi_r} |U_{\dagger}(\mathbf{x}')|^2 d\mathbf{x}' &= \lim_{R \rightarrow +\infty} \sum_{\pm} \int_{\varpi_r} U_{\dagger}(\mathbf{x}') \partial_1 v_2(\pm R, \mathbf{x}') d\mathbf{x}' \\ &= \sum_{\pm} \int_{\theta_r} U_{\dagger}(\mathbf{x}') \partial_1 v_2(\pm R, \mathbf{x}') d\mathbf{x}' \\ &= \sum_{\pm} \int_{\theta_r} U_{\dagger}(\mathbf{x}') \nabla' \cdot (h_{\pm}(\mathbf{x}') \nabla' v_1(\pm 0, \mathbf{x}')) d\mathbf{x}' \\ &= \sum_{\pm} \left(- \int_{\theta_r} h_{\pm}(\mathbf{x}') \nabla' U_{\dagger}(\mathbf{x}') \cdot \nabla' v_1(\pm 0, \mathbf{x}') d\mathbf{x}' \right. \\ &\quad \left. + \int_{\phi_r} h_{\pm}(x_2, 0) U_{\dagger}(x_2, 0) \partial_z v_1(\pm 0, x_2, 0) dx_2 \right) \\ &= \sum_{\pm} \left(\int_{\theta_r} v_1(\pm 0, \mathbf{x}') \nabla' h_{\pm}(\mathbf{x}') \cdot \nabla' U_{\dagger}(\mathbf{x}') d\mathbf{x}' \right. \\ &\quad \left. + \int_{\theta_r} v_1(\pm 0, \mathbf{x}') h_{\pm}(\mathbf{x}') \Delta' U_{\dagger}(\mathbf{x}') d\mathbf{x}' \right. \\ &\quad \left. + \int_{\phi_r} h_{\pm}(x_2, 0) (U_{\dagger}(x_2, 0) \partial_z v_1(\pm 0, x_2, 0) - v_1(\pm 0, x_2, 0) \partial_z U_{\dagger}(x_2, 0)) dx_2 \right). \end{aligned}$$

The last and second but last integrals vanish, due to the Steklov conditions (1.21), (2.16) and the Laplace equation (1.19), respectively. Hence, similarly to (2.25), we have

$$(73) \quad (3.21) \quad b_2^1 = -\frac{1}{2} \|U_{\dagger}; L^2(\varpi_r)\|^{-2} J(h),$$

where $J(h)$ is obtained by taking (2.19) into account and integrating by parts in Ω_r^0 :

$$J(h) = \sum_{\pm} \mp \int_{\theta_r} v_1(\pm 0, \mathbf{x}') \partial_1 v_1(\pm 0, \mathbf{x}') d\mathbf{x}'$$

$$\boxed{74} \quad (3.22) \quad = \int_{-\infty}^{\infty} \left(\int_{\varpi_r} |\nabla v_1(\mathbf{x})|^2 d\mathbf{x}' - \Lambda_{\dagger} \int_0^l |v_1(x_1, x_2, 0)|^2 dx_2 \right) dx_1.$$

We emphasize that the representation (3.8) of the bounded solution v_1 guarantees that the integrand

$$\boxed{75} \quad (3.23) \quad j(v_1; x_1) = \int_{\varpi_r} |\nabla v_1(\mathbf{x})|^2 d\mathbf{x}' - \Lambda_{\dagger} \int_0^l |v_1(x_1, x_2, 0)|^2 dx_2$$

decays exponentially at infinity: in view of (1.19)–(1.22), we have $j(U_{\dagger}) = 0$ and hence, constant terms become null in the asymptotics of (3.23) as $x_1 \rightarrow \pm\infty$. It is worth mentioning that the convergence of all integrals in (3.20) follows from the material in Section 3.3.

sec3.5

3.5. Asymptotics of the eigenvalue. In Section 4.1 we shall verify that the inequality

$$\boxed{76} \quad (3.24) \quad J(h) > 0$$

■ always holds under the general assumption of our paper. We are now in position to complete the matching procedure and to derive a formula for the correction term in (3.2). Recalling the conclusions (2.12) and (2.29) we compare linear terms in the coefficients of ε^2 in (3.6) and (3.7). According to (3.5), (3.19), and (3.21) we see that, first, $\mp\mu_1 = \pm b_2^1$, and, second,

$$\|U_{\dagger}; L^2(\varpi_r)\|^{-1} \lambda_1^{1/2} = \mu_1 = -b_2^1 = \frac{1}{2} \|U_{\dagger}; L^2(\varpi_r)\|^{-2} J(h).$$

Because of (3.24) we can write

$$\boxed{77} \quad (3.25) \quad \lambda_1 = \frac{1}{4} \|U_{\dagger}; L^2(\varpi_r)\|^{-2} J(h),$$

■ and formulate the main result on the asymptotics of the embedded eigenvalue in the case of the degenerate integral characteristic. The proof will be completed in Sections 4 and 5.

DGC **Theorem 3.1.** *Assume that the conditions 1°–3° hold true and that $I(h) = 0$, see (2.28). Then, there exist $\varepsilon_2 = \varepsilon_2(\theta, h_{\pm}) > 0$ and $c_2 > 0$ such that the problem (1.8)–(1.10) has for every $\varepsilon \in (0, \varepsilon_2]$ a unique eigenvalue (3.2) inside the segment $(0, \Lambda_{\dagger}]$. The correction term $\lambda_0 > 0$ is given by (3.25), (3.22) and the asymptotic remainder meets the estimate*

$$\boxed{78} \quad (3.26) \quad |\tilde{\lambda}^{\varepsilon}| \leq c_2 \varepsilon^{9/2}.$$

ses4c4

4. UNIQUENESS OF THE EMBEDDED EIGENVALUE.

4.1. Absence of trapped modes at the threshold. Section ■ 4 is devoted to the proof of the uniqueness statements in Theorems 1.1 and 3.1. Sections 4.1 and 4.2 contain preliminary results on eigenvalues at the threshold situation and in a truncated water domain. We start by proving that the problem (1.25)–(1.28) has no trapped modes at the threshold $\Lambda = \Lambda_{\dagger}$, cf. Section 2.3 and Theorems 1.1, 3.1. Let

$u^0 \in H_0^1(\Omega_r^0; \Upsilon^0)$ be a solution of this homogeneous problem. The Green formula gives ■

$$\boxed{79} \quad (4.1) \quad \int_{\Omega_r^0} \left| \frac{\partial u^0}{\partial x_1}(\mathbf{x}) \right|^2 d\mathbf{x} + \int_{\Omega_r^0} |\nabla' u^0(\mathbf{x})|^2 d\mathbf{x} - \Lambda_{\dagger} \int_{\Gamma_r^0} |u^0(x_1, x_2, 0)|^2 dx_1 dx_2 = 0.$$

The max-min-principle (1.23) implies for all $V \in H_0^1(\varpi_r; v)$

$$\boxed{80} \quad (4.2) \quad \int_{\Omega_r^0} |\nabla' V(\mathbf{x}')|^2 d\mathbf{x}' \geq \Lambda_{\dagger} \int_{\gamma_r} V(x_2, 0) dx_2.$$

Setting $V(\mathbf{x}') = u^0(x_1, \mathbf{x}')$ in (4.2) and integrating the result in $x_1 \in (-\infty, 0) \cup (0, +\infty)$ shows that the difference of the second and third integrals in (4.1) is non-negative. Hence,

$$\int_{\Omega_r^0} |\partial_1 u^0(\mathbf{x})|^2 d\mathbf{x} \leq 0$$

and therefore u^0 does not depend on the longitudinal variable x_1 . Owing to the decay of u^0 at infinity, this is possible only, if $u^0 = 0$.

A similar consideration proves the key inequality (3.24) of Section 3.5. Indeed, we have

$$J(h) = \int_{\Omega_r^0} \left| \partial_1 v_1(\mathbf{x}) \right|^2 d\mathbf{x} + \int_{-\infty}^{\infty} j(v_1; x_1) dx_1,$$

where the first integral converges, because the x_1 -derivative of the function (2.23) decays exponentially. The integrand (3.23) is non-negative due to the inequality (4.2), and thus $J(h) \geq 0$. ■ The equality $J(h) = 0$ is possible only in the case $\partial_1 v_1 = 0$ in Ω_r^0 . The asymptotic behaviour (3.8) shows that $v_1(\mathbf{x}) = \pm b_1^0 U_{\dagger}(\mathbf{x}')$ for $\pm x_1 > 0$, and due to the continuity of v_1 , this is possible only if $b_1^0 = 0$, i.e. $v_1 = 0$. But of course, the null function cannot be a solution of the problem (2.13)–(2.16) with inhomogeneous boundary conditions (2.19).

sec4.2

4.2. Asymptotics of eigenvalues in a bounded domain. In the next section we shall need some information on the eigenvalues of the problem

$$\boxed{07} \quad (4.3) \quad -\Delta w^\varepsilon(\mathbf{x}) = 0, \quad \mathbf{x} \in \Omega_r^\varepsilon(R),$$

$$\boxed{08} \quad (4.4) \quad \partial_\nu w^\varepsilon(\mathbf{x}) = 0, \quad \mathbf{x} \in \Sigma_r^\varepsilon(R) \cup \bigcup_{\pm} (\theta_{+,r}^\varepsilon \cup \varpi_r(\pm R)),$$

$$\boxed{09} \quad (4.5) \quad \partial_z w^\varepsilon(\mathbf{x}) = \beta^\varepsilon w^\varepsilon(\mathbf{x}), \quad \mathbf{x} \in \Gamma_r^\varepsilon(R),$$

$$\boxed{00} \quad (4.6) \quad w^\varepsilon(\mathbf{x}) = 0, \quad \mathbf{x} \in \Upsilon^\varepsilon(R)$$

in the bounded domain $\Omega_r^\varepsilon(R) = \{\mathbf{x} \in \Omega_r^\varepsilon : |x_1| < R\}$ with some fixed $R > 0$; the sets $\Sigma_r^\varepsilon(R)$, $\Gamma_r^\varepsilon(R)$, and $\Upsilon^\varepsilon(R)$ are defined similarly. On the truncated cross-sections $\varpi_r(\pm R)$, an artificial Neumann condition is imposed in (4.4), and the other conditions are inherited from (1.16)–(1.18). ■ Fixing R , we next derive an asymptotic formula for the lowest eigenvalue of this problem as $\varepsilon \rightarrow 0$.

Putting $\varepsilon = 0$ turns the problem (4.3)–(4.6) into the limit problem in the bounded cylinder $\Pi_r(R) = (-R, R) \times \varpi_r$ with the incision Θ_r^0 . For this problem, we readily find the eigenvalue $\beta_1^0 = \Lambda_{\dagger}$ and the corresponding eigenfunction $w_1^0(\mathbf{x}) = U_{\dagger}(\mathbf{x}')$.

Since $U_{\dagger} > 0$ in ϖ_r , the strong maximum principle shows that this is the first, simple eigenvalue. We shall also need the second eigenvalue

$$\boxed{81} \quad (4.7) \quad \beta_2^0 > \beta_1^0 = \Lambda_{\dagger},$$

which of course may be multiple.

In view of the assumption $\mathbf{3}^\circ$, Section 1.2 and the definition (1.3) of Θ^ε , there exists a diffeomorphism \varkappa of class $H^{1,\infty}$ which transforms $\Omega_r^\varepsilon(R)$ into $\Omega_r^0(R)$ and which is "almost identical",

$$|\varkappa^\varepsilon(\mathbf{x}) - \mathbf{x}| \leq c\varepsilon, \quad \left| \frac{d\varkappa^\varepsilon}{dx} - \text{Id} \right| \leq c\varepsilon.$$

According to [10, 7.6.5], see also [23, Ch. 5], this means that $\beta_p^\varepsilon = \beta_p^0 + O(\varepsilon)$ and in particular

$$\boxed{82} \quad (4.8) \quad \beta_2^\varepsilon > \Lambda_{\dagger} \quad \text{for } \varepsilon \in (0, \varepsilon_0]$$

by virtue of (4.8). Let us compute the asymptotics of β_1^ε .

In spite of the edge Ψ , the transition from Θ_r^ε to Θ_r^0 can be regarded as a regular perturbation of the boundary, cf. Section 3.3, and we thus choose the standard ansätze for the eigenvalue and the corresponding eigenfunction

$$\boxed{83} \quad (4.9) \quad \begin{aligned} \beta_1^\varepsilon &= \Lambda_{\dagger} - \alpha\varepsilon + \tilde{\beta}_1^\varepsilon, \\ w_1^\varepsilon(\mathbf{x}) &= U_{\dagger}(\mathbf{x}') + \varepsilon W(\mathbf{x}) + \tilde{w}_1^\varepsilon(\mathbf{x}). \end{aligned}$$

We insert them into the problem (4.3)–(4.6), repeat the arguments of Section 2.2 and thus obtain the following problem for the correction terms in (4.9):

$$\begin{aligned} -\Delta W(\mathbf{x}) &= 0, \quad \mathbf{x} \in \Omega_r^0(R), \\ \partial_\nu W(\mathbf{x}) &= 0, \quad \mathbf{x} \in \Sigma_r^0(R), \quad \pm \partial_1 W(\pm R, \mathbf{x}') = 0, \quad \mathbf{x} \in \varpi_r, \\ \pm \partial_1 W(\pm 0, \mathbf{x}') &= -\nabla' h_\pm(\mathbf{x}') \cdot \nabla' U_{\dagger}(\mathbf{x}'), \quad \mathbf{x}' \in \theta_r, \\ \partial_z W(\mathbf{x}) &= \Lambda_{\dagger} W(\mathbf{x}) - \alpha U_{\dagger}(\mathbf{x}'), \quad \mathbf{x} \in \Gamma_r^0(R), \\ W(\mathbf{x}) &= 0, \quad \mathbf{x} \in \Upsilon^0(R). \end{aligned}$$

Moreover, since the eigenvalue Λ_{\dagger} is simple, the only compatibility condition in this problem reads as

$$\begin{aligned} 0 &= \int_{\partial\Omega_r^0} (U_{\dagger}(\mathbf{x}') \partial_\nu W(\mathbf{x}) - W(\mathbf{x}) \partial_\nu U_{\dagger}(\mathbf{x}')) ds_{\mathbf{x}} \\ &= -\alpha \int_{\Gamma_r^0(R)} |U_{\dagger}(x_2, 0)|^2 dx_1 dx_2 - \sum_{\pm} \int_{\theta_r} U_{\dagger}(\mathbf{x}') \nabla' h_\pm(\mathbf{x}') \cdot \nabla' U_{\dagger}(\mathbf{x}') d\mathbf{x}'. \end{aligned}$$

Hence, (1.24), (2.26), (2.28) imply

$$\boxed{84} \quad (4.10) \quad \alpha = (2R)^{-1} I(h).$$

Finally, again according to [10, 7.6.5], the remainder in (4.9) can be bounded by

$$\boxed{85} \quad (4.11) \quad |\tilde{\beta}_1^\varepsilon| \leq c\varepsilon^2.$$

FINITE **Remark 4.1.** We emphasize the obvious difference of the asymptotic ansätze (2.1) and (4.9) for the eigenvalues in the infinite waveguide Ω_r^ε and its truncated part $\Omega_r^\varepsilon(R)$. Moreover, the relations (2.31) and (4.10) have been derived with crucially different arguments. These observations are discussed in detail in the paper [19].

sec4.3

4.3. Max-min-principle. We ■ now complete the uniqueness proof by using the methods of [18], which involve the introduction of an abstract linear operator \mathcal{T}^ε in a Sobolev-type Hilbert space and the use of the max-min-principle. We equip the Sobolev-space $\mathcal{H}^\varepsilon = H_0^1(\Omega_r^\varepsilon; \Upsilon^\varepsilon)$ with the scalar product

$$\boxed{86} \quad (4.12) \quad \langle u^\varepsilon, v^\varepsilon \rangle = (\nabla u^\varepsilon, \nabla v^\varepsilon)_{\Omega_r^\varepsilon}$$

and define the operator \mathcal{T}^ε by the identity

$$\boxed{87} \quad (4.13) \quad \langle \mathcal{T}^\varepsilon u^\varepsilon, v^\varepsilon \rangle = (u^\varepsilon, v^\varepsilon)_{\Gamma_r^\varepsilon},$$

where $(\cdot, \cdot)_\Xi$ stands for the natural scalar product of the Lebesgue space $L^2(\Xi)$. The inequality

$$\boxed{88} \quad (4.14) \quad \|u^\varepsilon; L^2(\Omega_r^\varepsilon)\|^2 + \|u^\varepsilon; L^2(\Gamma_r^\varepsilon)\|^2 \leq c \|\nabla u^\varepsilon; L^2(\Omega_r^\varepsilon)\|^2$$

follows from the standard Friedrichs inequality in the truncated channel,

$$\boxed{89} \quad (4.15) \quad \|u^\varepsilon; L^2(\Omega_r^\varepsilon(R))\|^2 + \|u^\varepsilon; L^2(\Gamma_r^\varepsilon(R))\|^2 \leq c \|\nabla u^\varepsilon; L^2(\Omega_r^\varepsilon(R))\|^2,$$

and the trace inequality in the cross-section ϖ ,

$$\boxed{90} \quad (4.16) \quad \|U^\varepsilon; L^2(\varpi_r)\|^2 + \|U^\varepsilon; L^2(\gamma_r)\|^2 \leq c \|\nabla' U^\varepsilon; L^2(\varpi_r)\|^2.$$

These inequalities are valid owing to the Dirichlet conditions (1.18) and (1.22), respectively. In (4.16) we set $U^\varepsilon(\mathbf{x}') = u^\varepsilon(\mathbf{x})$ and in addition integrate over $x_1 \in (-\infty, -R) \cup (R, +\infty)$. The constant c in (4.15) does not depend on ε , since the parts of the surface $\partial\Omega_r^\varepsilon$ which are inside Π_r can be considered as graphs of functions in the variable \mathbf{x}' , cf. [30].

The inequality (4.14) and the definition of the inner product (4.12) imply that the operator \mathcal{T}^ε is continuous, positive, and symmetric, hence, self-adjoint. Moreover, by (4.12) and (4.13), the variational formulation of the problem (1.15)–(1.18),

$$(4.17) \quad (\nabla u^\varepsilon, \nabla v^\varepsilon)_{\Omega_r^\varepsilon} = \lambda^\varepsilon (u^\varepsilon, v^\varepsilon)_{\Gamma_r^\varepsilon} \quad \forall v^\varepsilon \in H_0^1(\Omega_r^\varepsilon; \Upsilon^\varepsilon),$$

can be formulated as the abstract equation

$$\boxed{92} \quad (4.18) \quad \mathcal{T}^\varepsilon u^\varepsilon = \tau^\varepsilon u^\varepsilon \quad \text{in } \mathcal{H}^\varepsilon,$$

with the new spectral parameter

$$\boxed{93} \quad (4.19) \quad \tau^\varepsilon = 1/\lambda^\varepsilon.$$

This relation implies that the continuous spectrum of \mathcal{T}^ε is ■ $[0, \Lambda_\dagger^{-1}]$. Moreover, the operator $-\mathcal{T}^\varepsilon$ (with the minus sign) is bounded from below and eigenvalues $\tau_1^\varepsilon, \dots, \tau_N^\varepsilon$ in its discrete spectrum can be obtained from the max-min-principle

$$\boxed{94} \quad (4.20) \quad -\tau_n^\varepsilon = \max_{\mathcal{H}_n^\varepsilon} \min_{v^\varepsilon \in \mathcal{H}_n^\varepsilon \setminus \{0\}} \frac{-\langle \mathcal{T}^\varepsilon v^\varepsilon, v^\varepsilon \rangle}{\langle v^\varepsilon, v^\varepsilon \rangle},$$

where $\mathcal{H}_n^\varepsilon$ is any subspace of \mathcal{H}^ε with codimension $n - 1$. More precisely, Theorem 10.2.2. of [2] or ■ Theorem XIII.1 of [26] state that if the right hand side of (4.20) is less than Λ_\dagger^{-1} , then the discrete spectrum of \mathcal{T}^ε contains at least n points, which thus are isolated eigenvalues. By the relation (4.19) this also means that the discrete spectrum of the problem (1.15)–(1.18) contains at most n points.

Let us assume that $I(h)$, (2.28), is negative. Then, by (4.10) and (4.11), the first eigenvalue (4.9) of the auxiliary problem (4.3)–(4.6) in the bounded domain satisfies $\beta_1^\varepsilon \geq \lambda_\dagger$ for small $\varepsilon \in (0, \varepsilon_0]$ and therefore we have the inequality ¹

$$\boxed{95} \quad (4.21) \quad \|\nabla v^\varepsilon; L^2(\Omega_r^\varepsilon(R))\|^2 \geq \beta_p^\varepsilon \|v^\varepsilon; L^2(\Gamma_r^\varepsilon(R))\|^2.$$

We take the inequality (4.2) with $V(\mathbf{x}') = v^\varepsilon(x_1, \mathbf{x}')$, integrate it in $x_1 \in (-\infty, -R) \cup (R, +\infty)$, add it to (4.21) and obtain

$$\boxed{96} \quad (4.22) \quad \|\nabla v^\varepsilon; L^2(\Omega_r)\|^2 \geq \Lambda_\dagger \|v^\varepsilon; L^2(\Omega_r)\|^2.$$

Thus, for all $v^\varepsilon \in \mathcal{H}^\varepsilon$ we have

$$\boxed{97} \quad (4.23) \quad \frac{-\langle \mathcal{T}^\varepsilon v^\varepsilon, v^\varepsilon \rangle}{\langle v^\varepsilon, v^\varepsilon \rangle} = -\frac{\|v^\varepsilon; L^2(\Gamma_r^\varepsilon)\|^2}{\|\nabla v^\varepsilon; L^2(\Omega_r^\varepsilon)\|^2} \geq -\frac{1}{\Lambda_\dagger},$$

so that the right hand side of (4.20) with $n = 1$ exceeds $-\lambda_\dagger$. By the above mentioned theorems of [2] and [26], the discrete spectrum of \mathcal{T}^ε is empty. ■ By the remark after (4.20), this means that the discrete spectrum of the problem (1.15)–(1.18) is empty as well, and as explained above Remark 1.2, this implies that there are no embedded eigenvalues for the problem (1.8)–(1.10) contained in the interval $[0, \Lambda_\dagger]$. The first assertion of Theorem 1.1 has thus been verified.

Let $I(h) \geq 0$. We now deal with the second eigenvalue β_2^ε and introduce the subspace of codimension 1,

$$\boxed{98} \quad (4.24) \quad \mathcal{H}_\perp^\varepsilon = \left\{ v^\varepsilon \in H_0^1(\Omega_r^\varepsilon; \Gamma_r^\varepsilon) : \int_{\Omega_r^\varepsilon(R)} v^\varepsilon(\mathbf{x}) w_1^\varepsilon(\mathbf{x}) d\mathbf{x} = 0 \right\}.$$

In (4.24), w_1^ε is the first eigenfunction of the problem (4.3)–(4.6). Owing to the orthogonality condition in (4.24), any function $v^\varepsilon \in \mathcal{H}_\perp^\varepsilon$ satisfies the relation (4.21) ■ with $p = 2$, which is an inequality of Poincaré type. We obtain the formula (4.22) by (4.7) and (4.2) and conclude that

$$\inf_{v^\varepsilon \in \mathcal{H}^\varepsilon \setminus \{0\}} \frac{-\langle \mathcal{T}^\varepsilon v^\varepsilon, v^\varepsilon \rangle}{\langle v^\varepsilon, v^\varepsilon \rangle} = -\sup_{v^\varepsilon \in \mathcal{H}^\varepsilon \setminus \{0\}} \frac{\|v^\varepsilon; L^2(\Gamma_r^\varepsilon)\|^2}{\|\nabla v^\varepsilon; L^2(\Omega_r^\varepsilon)\|^2} \geq -\frac{1}{\Lambda_\dagger} \geq -\frac{1}{\Lambda_\dagger}.$$

Once more, the above mentioned theorems of [2] or [26] implies that the discrete spectrum of the operator \mathcal{T}^ε can ■ contain at most one eigenvalue. As in the previous case we deduce that the problem (1.8)–(1.10) can have at most one eigenvalue in the interval $[0, \Lambda_\dagger]$.

The uniqueness statements in Theorems 1.1, (2), and 3.1 have been confirmed.

5. EXISTENCE OF AN EIGENVALUE.

§§§§§

5.1. Searching for an eigenvalue. We shall construct a non-trivial function $u_{\text{as}}^\varepsilon \in H^1(\Omega_r^\varepsilon, v^\varepsilon)$ and find positive numbers ■ $\tau_{\text{as}}^\varepsilon, \delta$ such that

$$\boxed{B1} \quad (5.1) \quad \|\mathcal{T}^\varepsilon u_{\text{as}}^\varepsilon - \tau_{\text{as}}^\varepsilon u_{\text{as}}^\varepsilon; \mathcal{H}^\varepsilon\| = \delta \|u_{\text{as}}^\varepsilon; \mathcal{H}^\varepsilon\|,$$

$$\boxed{B77} \quad (5.2) \quad \tau_{\text{as}}^\varepsilon - \delta > \Lambda_\dagger^{-1}.$$

A classical lemma on "approximate eigenvalues", see e.g. [31], and the formulas (5.1), (5.2) guarantee that the segment $[\tau_{\text{as}}^\varepsilon - \delta, \tau_{\text{as}}^\varepsilon + \delta]$ does not intersect the continuous spectrum $[0, \lambda_\dagger^{-1}]$ and contains an eigenvalue τ_1^ε of the operator \mathcal{T}^ε . Then,

¹This inequality is quite similar to (4.2) and both of them can be derived by using a reduction to an abstract equation and applying the min-principle.

the relation (4.19) of the spectral parameters implies the existence of the eigenvalue $\lambda_1^\varepsilon = 1/\tau_1^\varepsilon \in (0, \Lambda_\dagger)$ of the problem (1.15)–(1.18) \blacksquare and thus of the problem (1.8)–(1.10), as well as the estimate

$$\boxed{\text{B2}} \quad (5.3) \quad |\lambda_1^\varepsilon - \lambda_{\text{as}}^\varepsilon| \leq C_\varepsilon \delta \quad \text{with} \quad \lambda_{\text{as}}^\varepsilon = \frac{1}{\tau_{\text{as}}^\varepsilon}, \quad C_\varepsilon = \frac{\delta}{\tau_{\text{as}}^\varepsilon(\tau_{\text{as}} - \delta)}.$$

In the previous section we have proved that an eigenvalue in $(0, \Lambda_\dagger)$ is unique, if it exists. That is why the above mentioned lemma additionally yields an eigenfunction $u_1^\varepsilon \in H_0^1(\Omega_r^\varepsilon; \Upsilon^\varepsilon)$, which corresponds to λ_1^ε , but is not necessarily normalized in \mathcal{H}^ε , and satisfies the estimate

$$\boxed{\text{B3}} \quad (5.4) \quad \|u_1^\varepsilon - u_{\text{as}}^\varepsilon; \mathcal{H}^\varepsilon\| \leq \delta \|u_{\text{as}}^\varepsilon; \mathcal{H}^\varepsilon\|.$$

The simplest way to derive these and similar facts is to apply elementary tools of the theory of the spectral measure; in this way the reduction to the abstract equation becomes very important. In particular, the key estimate

$$\boxed{\text{B4}} \quad (5.5) \quad |\tau_1^\varepsilon - \tau_{\text{as}}^\varepsilon| \leq \delta$$

is a consequence of the spectral decomposition of the resolvent, see [2, §6.2], which includes an estimate of the distance of a point to the spectrum in terms of the norm of the resolvent, see (5.1). The estimate (5.4) for the eigenfunction follows by using the spectral projection. A detailed explanation of this technique is given for example in [25].

sec5.2

5.2. Approximate eigenvalue and eigenfunction. We assume the condition $I(h) > 0$ and set

$$\boxed{\text{B0}} \quad (5.6) \quad \lambda_{\text{as}}^\varepsilon = \Lambda_\dagger - \varepsilon^2 \lambda_0$$

and correspondingly $\tau_{\text{as}}^\varepsilon = (\Lambda_\dagger - \varepsilon^2 \lambda_0)^{-1}$; here λ_0 is taken from (2.31). Moreover, by $\{\mu_{\text{as}}(\varepsilon), V_{\text{as}}(\varepsilon; \mathbf{x}')\}$ we understand the solution (2.4) of the model problem (2.3) on ϖ_r with the spectral parameter (5.6).

We \blacksquare connect the inner and outer expansions (2.11) and (2.2) of Section 2 by using the smooth cut-off functions (2.21) and the function

$$\boxed{\text{B5}} \quad (5.7) \quad X_\varepsilon(x_1) = 1 \text{ for } |x_1| < 1/\varepsilon, \quad X_\varepsilon(x_1) = 0 \text{ for } |x_1| > 1 + 1/\varepsilon, \quad 0 \leq X_\varepsilon \leq 1.$$

Namely, we set

$$\boxed{\text{B6}} \quad (5.8) \quad u_{\text{as}}^\varepsilon(\mathbf{x}) = X_\varepsilon(x_1)(v_0(\mathbf{x}) + \varepsilon v_1(\mathbf{x})) + \sum_{\pm} \chi_{\pm}(x_1)(1 \pm \varepsilon \beta_1^0) e^{\mp \mu(\varepsilon)x_1} V(\varepsilon; \mathbf{x}') \\ - X_\varepsilon(x_1) \sum_{\pm} \chi_{\pm}(x_1)(1 + \varepsilon(\beta_1^1|x_1| \pm \beta_1^0)) U_{\dagger}(\mathbf{x}').$$

The supports of the cut-off-functions (2.21) and (5.7) overlap like in Fig. 5.1.a. Therefore the terms which have been matched in Section 2.3 are taken into account twice in the first and second terms, but this duplication is compensated by subtracting the third term.

We emphasize that in the case $h_{\pm} > 0$, when $\overline{\Theta^0} \subset \Theta^\varepsilon$ and θ_{\pm}^ε lays inside $\Pi_{\pm} = \{\mathbf{x} \in \Pi : \pm x_1 > 0\}$, we may just use the function v_1 in (5.8), but in the case when the surfaces θ_{\pm}^ε penetrate in Θ^0 , this function must be substituted by its extension v_1^{\pm} through the screen Θ_r^0 . For example, if $-h_- < h_+ < 0$ in θ , see Fig. 3.1.b, v_1 must be extended from $\Pi_{+,r}$ to the domain

$$\boxed{\text{B7}} \quad (5.9) \quad \{\mathbf{x} \in \Pi_r : x_1 > 0 \text{ for } \mathbf{x}' \in \varpi_r \setminus \overline{\theta}_r, \quad x_1 > \varepsilon h_+(\mathbf{x}') \text{ for } \mathbf{x}' \in \theta_r\}.$$

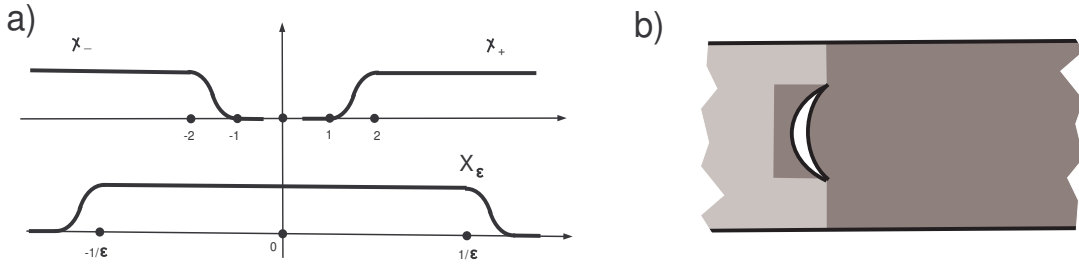

FIGURE 5.1. a) Cut-off-functions with overlapping supports. b) Extension through the screen.

fig4

We take a smooth extension, which has a singularity at the edge (1.30); the larger domain is shaded in Fig. 5.1.b. More precisely, we use the representation (3.17) near the edge and keep the form of $K_0(s)$, $K_1(s)r^{1/2}\cos(\varphi/2)$ unchanged and handle the remainder \widehat{v}_1 only. In this way the extensions \widehat{v}_1^\pm will still satisfy the estimates (3.18).

To avoid superfluous technical details we describe the first case and only comment on the second one at the end.

Let us derive a lower estimate for the L^2 -norm of the function (5.8) written in the form

$$u_{\text{as}}^\varepsilon(\mathbf{x}) = \left(1 - \sum_{\pm} \chi_{\pm}(x_1)\right) U_{\dagger}(\mathbf{x}') + X_\varepsilon(x_1)\varepsilon\widetilde{v}_1(\mathbf{x}) + \sum_{\pm} \chi_{\pm}(x_1)(1 \pm \varepsilon b_1^0)e^{\mp\mu(\varepsilon)} U_{\dagger}(\mathbf{x}'),$$

where the formulas (2.12) for v_0 and (2.23) for v_1 were applied. The first term on the right has compact support and the second one decays exponentially, but, according to (2.4), the decay of the third term is very slow. Thus,

$$\begin{aligned} \|u_{\text{as}}^\varepsilon; L^2(\Omega_r^\varepsilon)\|^2 &\geq \|u_{\text{as}}^\varepsilon; L^2(\Omega_r^\varepsilon \setminus \Omega_r^\varepsilon(2))\|^2 \\ \text{B99} \quad (5.10) \quad &\geq C_1 \int_2^\infty e^{-2\varepsilon\mu_0|x_1|} d|x_1| - C_0\varepsilon \geq \frac{C_2}{\varepsilon}, \quad C_p > 0, \end{aligned}$$

■ where $\Omega_r^\varepsilon(2)$ is as in (4.3).

sec5.3

5.3. Calculation of the discrepancies. Let us compute in the equation (1.15) the discrepancy of the function (5.8), which is written more briefly as follows:

$$\text{B8} \quad (5.11) \quad u_{\text{as}}^\varepsilon = X_\varepsilon u_{\text{in}}^\varepsilon + \sum_{\pm} \chi_{\pm} u_{\text{out},\pm}^\varepsilon - X_\varepsilon \sum_{\pm} \chi_{\pm} u_{\text{mat},\pm}^\varepsilon.$$

We denote by $[\Delta, X_\varepsilon]$ the commutator of the Laplace operator with the cut-off-function X_ε and observe that

$$[\Delta, X_\varepsilon \chi_{\pm}] = \chi_{\pm} [\Delta, X_\varepsilon] + [\Delta, \chi_{\pm}],$$

hence,

$$\Delta u_{\text{as}}^\varepsilon = X_\varepsilon \Delta u_{\text{in}}^\varepsilon + \sum_{\pm} \chi_{\pm} (\Delta u_{\text{out},\pm}^\varepsilon - X_\varepsilon u_{\text{mat},\pm}^\varepsilon)$$

$$\boxed{\text{B9}} \quad (5.12) \quad + \sum_{\pm} \chi_{\pm}[\Delta, X_{\varepsilon}](u_{\text{in},\pm}^{\varepsilon} - u_{\text{mat},\pm}^{\varepsilon}) + \sum_{\pm} [\Delta, X_{\varepsilon}](u_{\text{out},\pm}^{\varepsilon} - u_{\text{mat},\pm}^{\varepsilon}).$$

Since $u_{\text{in}}^{\varepsilon}$, $u_{\text{out},\pm}^{\varepsilon}$, and $u_{\text{mat},\pm}^{\varepsilon}$ are harmonic, the first two terms on the right vanish. Coefficients of the differential operator $\chi_{\pm}[\Delta, X_{\varepsilon}]$ are supported in $\{\mathbf{x} \in \overline{\Pi}_r : \pm x_1 - 1/\varepsilon \in [0, 1]\}$, where the difference $u_{\text{in}}^{\varepsilon} - u_{\text{mat},\pm}^{\varepsilon} = \varepsilon \tilde{v}_1$ is exponentially small, see (2.12) and (2.23). Recalling the asymptotic formulas (2.4) and (2.8) and the decomposition (2.10) specified in (2.9), (2.12), (2.29), and (2.25), we conclude that the difference $u_{\text{out},\pm}^{\varepsilon} - u_{\text{mat},\pm}^{\varepsilon}$ is of the order ε^2 in the set $\{\mathbf{x} \in \overline{\Pi}_r : 1 \leq \pm x_1 \leq 2\}$. In this set the commutator $[\Delta, \chi_{\pm}]$ is not null, in view of (2.21). Hence,

$$\boxed{\text{B10}} \quad (5.13) \quad |\Delta u_{\text{as}}^{\varepsilon}(\mathbf{x})| \leq C\varepsilon^2 e^{-\alpha_0|x_1|} \quad \text{for some } \alpha_0 > 0.$$

On the cylindrical surface $\partial\Pi$ the normal derivative annihilates all three cut-off functions depending on the longitudinal variable only. We thus find that the asymptotic solution (5.8) satisfies the Neumann condition

$$\boxed{\text{B11}} \quad (5.14) \quad \partial_{\nu} u_{\text{as}}^{\varepsilon}(\mathbf{x}) = 0, \quad \mathbf{x} \in \Sigma_r^{\varepsilon},$$

and the discrepancy in the Steklov condition looks as follows:

$$\begin{aligned} \partial_z u^{\varepsilon}(\mathbf{x}) - (\Lambda_{\dagger} - \varepsilon^2 \lambda_0) u_{\text{as}}^{\varepsilon}(\mathbf{x}) &= \varepsilon^2 \lambda_0 X_{\varepsilon}(x_1) \left(u_{\text{in}}^{\varepsilon}(\mathbf{x}) - \sum_{\pm} \chi_{\pm}(x_1) u_{\text{mat},\pm}^{\varepsilon}(\mathbf{x}) \right) \\ &= \varepsilon^2 \lambda_0 \left(1 - \sum_{\pm} \chi_{\pm}(\mathbf{x}) \right) U_{\dagger}(\mathbf{x}') + X_{\varepsilon}(x_1) \varepsilon^3 \tilde{v}_1(\mathbf{x}), \quad \mathbf{x} \in \Gamma_r^{\varepsilon}. \end{aligned}$$

Recalling the exponential decay of the remainder in (2.23) we see that

$$\boxed{\text{B12}} \quad (5.15) \quad |\partial_z u^{\varepsilon}(x_1, x_2, 0) - \lambda_{\text{as}}^{\varepsilon} u^{\varepsilon}(x_1, x_2, 0)| \leq c\varepsilon^2 e^{-\alpha_0|x_1|}, \quad \mathbf{x} \in \Omega_r^{\varepsilon}.$$

We are left with examining the boundary conditions (1.16) on the screen surfaces (1.5). Clearly, $u_{\text{as}}^{\varepsilon}(\mathbf{x}) = U_{\dagger}(\mathbf{x}') + \varepsilon v_1(\mathbf{x})$ in a neighbourhood of Θ_r^{ε} . We use the representation (2.17) for the normal derivative and the relation (2.19). As a result, we obtain

$$\begin{aligned} & \left(1 + \varepsilon^2 |\nabla' h_{\pm}(\mathbf{x}')|^2 \right)^{1/2} \partial_{\nu_{\pm}} (U_{\dagger}(\mathbf{x}') + \varepsilon v_1(\mathbf{x})) \Big|_{x_1 = \pm \varepsilon h(\mathbf{x}')} \\ &= \varepsilon (\nabla' h_{\pm}(\mathbf{x}') \cdot \nabla' U_{\dagger}(\mathbf{x}') \mp \partial_1 v_1(\pm \varepsilon h_{\pm}(\mathbf{x}'), \mathbf{x}') + \varepsilon \nabla' h_{\pm}(\mathbf{x}') \cdot \nabla' v_1(\pm \varepsilon h_{\pm}(\mathbf{x}'), \mathbf{x}')) \\ &= \pm \varepsilon (\partial_1 v_1(\pm 0, \mathbf{x}') - \partial_1 v_1(\pm \varepsilon h_{\pm}(\mathbf{x}'), \mathbf{x}') + \varepsilon^2 \nabla' h_{\pm}(\mathbf{x}') \cdot \nabla' v_1(\pm \varepsilon h_{\pm}(\mathbf{x}'), \mathbf{x}')) \end{aligned}$$

Applying the Taylor formula and the estimates

$$(5.16) \quad |\nabla^p v(\mathbf{x})| \leq c_p (1 + r^{-p+1/2} + r^{1/2}(L-s)^{1-p}), \quad p = 0, 1, 2,$$

which follow for example from the relations (3.17) and (3.18), yield the inequality

$$\boxed{\text{B13}} \quad (5.17) \quad \left| \partial_{\nu_{\pm}} (U_{\dagger}(\mathbf{x}') + \varepsilon v_1(\pm \varepsilon h_{\pm}(\mathbf{x}'), \mathbf{x}')) \right| \leq c\varepsilon^2 r^{-1/2}, \quad \mathbf{x} \in \theta_{\pm,r}^{\varepsilon}.$$

sec5.4

5.4. Final estimate. By the definition of the Hilbert space norm and the formulas (4.12), (4.13) we have

$$\begin{aligned} & \| \mathcal{T}^{\varepsilon} u_{\text{as}}^{\varepsilon} - \tau_{\text{as}}^{\varepsilon} u_{\text{as}}^{\varepsilon}; \mathcal{H}^{\varepsilon} \| = \inf \left| \langle \mathcal{T}^{\varepsilon} u_{\text{as}}^{\varepsilon}, w^{\varepsilon} \rangle - \tau_{\text{as}}^{\varepsilon} \langle u_{\text{as}}^{\varepsilon}, w^{\varepsilon} \rangle \right| \\ &= \tau_{\text{as}}^{\varepsilon} \inf \left| \lambda_{\text{as}}^{\varepsilon} \langle u_{\text{as}}^{\varepsilon}, w^{\varepsilon} \rangle_{\Gamma_r^{\varepsilon}} - \langle \nabla u_{\text{as}}^{\varepsilon}, \nabla w^{\varepsilon} \rangle_{\Omega_r^{\varepsilon}} \right| \\ &= \tau_{\text{as}}^{\varepsilon} \inf \left| \langle \Delta u_{\text{as}}^{\varepsilon}, \nabla w^{\varepsilon} \rangle_{\Omega_r^{\varepsilon}} - \langle \partial_z u_{\text{as}}^{\varepsilon} - \lambda_{\text{as}}^{\varepsilon} u_{\text{as}}^{\varepsilon}, w^{\varepsilon} \rangle_{\Gamma_r^{\varepsilon}} - \sum_{\pm} \langle \partial_{\nu_{\pm}} u_{\text{as}}^{\varepsilon}, w^{\varepsilon} \rangle_{\theta_{\pm,r}^{\varepsilon}} \right|. \end{aligned}$$

Here, the infimum is calculated over all functions $v^\varepsilon \in \mathcal{H}^\varepsilon$ such that

$$\|w^\varepsilon; \mathcal{H}^\varepsilon\| = \|\nabla w^\varepsilon; L^2(\Omega_r^\varepsilon)\| = 1;$$

according to (4.15) and (3.16), these functions also satisfy

$$\boxed{\text{BB1}} \quad (5.18) \quad \|w^\varepsilon, L^2(\Omega_r^\varepsilon)\| + \|w^\varepsilon, L^2(\Gamma_r^\varepsilon)\| + \sum_{\pm} \|r^{-1/2}(1 + |\ln r|)^{-1}w^\varepsilon; L^2(\theta_{\pm, r}^\varepsilon)\| \leq C.$$

Now the estimates (5.13), (5.15), and (5.17) imply the inequality

$$\boxed{\text{B14}} \quad (5.19) \quad \|\mathcal{T}^\varepsilon u_{\text{as}}^\varepsilon - \tau_{\text{as}}^\varepsilon u_{\text{as}}^\varepsilon; \mathcal{H}^\varepsilon\| \leq c\varepsilon^2,$$

which together with (5.10) show that the factor in (5.1) does not exceed $c\varepsilon^{5/2}$, and therefore (5.2) is true. Hence, the operator \mathcal{T}^ε has an eigenvalue $\tau_1^\varepsilon \in [\tau_{\text{as}}^\varepsilon - \delta, \tau_{\text{as}}^\varepsilon + \delta]$. Finally, the calculation (5.3) and the formula (5.6) assure the relations (2.1) and (1.12) for the eigenvalue $\lambda^\varepsilon = \lambda_1^\varepsilon = (\tau_1^\varepsilon)^{-1}$ of the problems (1.15)–(1.18) and (1.8)–(1.10). Theorem 1.1 is proved.

Let us comment on the case $h_+ < 0$ depicted in Fig. 5.1.b, and outlined at the end of Section 3.3. The formulas (5.14) and (5.17) remain unchanged. The extension v_1^+ is not harmonic in the thin domain $\Xi_+^\varepsilon = \{\mathbf{x} : 0 > x_1 > \varepsilon h_+(\mathbf{x}'), \mathbf{x}' \in \theta_r\}$, and therefore

$$(5.20) \quad \Delta u_{\text{as}}^\varepsilon(\mathbf{x}) = 0 \text{ in } \Pi_{+, r} \text{ but } \Delta u_{\text{as}}^\varepsilon(\mathbf{x}) = \varepsilon \Delta v_1^+(\mathbf{x}) \text{ in } \Xi_+^\varepsilon.$$

However, according to the relations (3.17), (3.18) and the Taylor formula in the variable x_1 , we have

$$|\nabla v_1^+(\mathbf{x})| = |\Delta v_1^+(\mathbf{x}) - \Delta v_1^+(+0, \mathbf{x}')| \leq C|x_1|r^{-3/2}(1 + |\ln \varrho|).$$

Furthermore, a direct consequence of the Newton-Leibnitz formula

$$\boxed{\text{B15}} \quad (5.21) \quad \int_{\Xi_+^\varepsilon} |w^\varepsilon(\mathbf{x})|^2 d\mathbf{x} \leq c\varepsilon \int_{\Omega_r^\varepsilon} (|\nabla w^\varepsilon(\mathbf{x})|^2 + |w^\varepsilon(\mathbf{x})|^2) d\mathbf{x}$$

shows that

$$\begin{aligned} & \varepsilon \left| \int_{\Xi_+^\varepsilon} w^\varepsilon(\mathbf{x}) \Delta v_1^+(\mathbf{x}) d\mathbf{x} \right|^2 \\ & \leq c\varepsilon \varepsilon^{1/2} \|w^\varepsilon; \Omega_r^\varepsilon(R)\| \left(\int_{\varepsilon h_+(\mathbf{x}')}^0 |x_1|^2 \int_{\theta_r} r^{-3} (1 + |\ln \varrho|)^2 d\mathbf{x}' dx_1 \right)^{1/2} \\ & \leq c\varepsilon^3 \left(\int_{\theta_r} h_+(\mathbf{x}')^3 r^{-3} (1 + |\ln \varrho|)^2 d\mathbf{x}' \right)^{1/2} \leq c\varepsilon^3. \end{aligned}$$

Here we used the relation (5.18) for w^ε and observed that the last integral converges because the singular factor r^{-3} is compensated by $h_+(\mathbf{x}')^3$, owing to the assumption $\mathbf{3}^\circ$. A similar calculation shows that

$$\boxed{\text{B16}} \quad (5.22) \quad |(\partial_z u_{\text{as}}^\varepsilon - \lambda_{\text{as}}^\varepsilon u_{\text{as}}^\varepsilon, w^\varepsilon)_{\Gamma_r^\varepsilon}| \leq c\varepsilon^2,$$

and hence our previous conclusion (5.19) as well as Theorem 1.1, (2) are still valid. It should be mentioned that instead of (5.21) the derivation of (5.22) can be based

on the estimate

$$\int_0^l \int_{\varepsilon h_+(x_2, 0)}^0 |w^\varepsilon(x_1, x_2, 0)|^2 dx_1 dx_2 \leq c\varepsilon(1 + |\ln \varepsilon|)^2 \|w^\varepsilon; H^1(\Omega_r^\varepsilon(R))\|^2$$

which follows from a Hardy-type trace inequality analogous to (3.16).

Theorem 1.1 can be proven in the same way but the extension of the asymptotic ansätze in Section 3.1 requires much more cumbersome but still routine calculations, which we omit here for brevity.

se6c6

6. CONCLUDING REMARKS.

6.1. Discussion. In the previous sections we have studied the position of the lowest embedded eigenvalue λ^ε of the linear water-wave problem (1.8)–(1.10) in a straight channel containing a thin screen. The thickness of the screen has been considered as a small parameter of order $\varepsilon > 0$, and we have assumed that the geometry of the problem is symmetric along the longitudinal mid-plane. Our results in Theorems 1.1 and 3.1 show how the integral characteristic $I(h)$, (2.28), and the lowest eigenvalue Λ_\dagger of the associated water-wave problem with artificial boundary condition (1.15)–(1.20) play crucial roles in the determination of the asymptotic position of λ^ε .

■ Our formal analysis, with small modifications, can be applied to asymmetric screens, but this topic will be postponed to a planned forthcoming paper, since the justification scheme would require essential changes. Asymmetry of the screen may lead to complex resonances or unstable embedded eigenvalues. (Notice that the eigenvalue found above belongs to the discrete spectrum of the problem (1.15)–(1.18) with the artificial Dirichlet condition, and it is therefore stable for small, symmetric perturbations of the profile functions h_\pm in (1.3).)

As for possible other embedded eigenvalues, we have not made any effort to analyse for example eigenvalues above the threshold Λ_\dagger . Embedded eigenvalues are in general unstable by nature. This has to be taken into account in the asymptotic analysis of eigenvalues larger than Λ_\dagger , and the investigation of such eigenvalues should be based on the fine-tuning procedure of [21, 22] mentioned already in Section 1.2; this also allows one to stabilise the eigenvalues to stay in the continuous spectrum. Since the present approach does not include a stabilisation procedure, we refrain from the computing of numerical examples, which would require ideas beyond the scope of the paper.

Let us make some further comments on the relation with the results of [18]. The sufficient condition for the existence of a trapped mode in [18] was formulated as the inequality

$$\text{R1} \quad (6.1) \quad \int_{\Theta_\varepsilon} |\nabla' U_\dagger(\mathbf{x}')|^2 d\mathbf{x} - \Lambda_\dagger \int_{\Gamma \cap \Theta_\varepsilon} |U_\dagger(\mathbf{x}')|^2 dx_1 dx_2 \geq 0.$$

This turns into the inequality $\varepsilon I(h) \geq 0$, (2.28), by using (1.3) and an integration with respect to x_1 . If $\mathfrak{3}^\circ$ is in addition assumed, Theorems 1.1 and 3.1 yield a positive number $\varepsilon_0(\theta, h_\pm)$ depending on the screen profiles such that if $0 < \varepsilon < \varepsilon_0(\theta, h_\pm)$, then (6.1) is also a necessary condition for a unique trapped mode, thus improving the results of [18]. For large ε this necessity and uniqueness may of course be lost.

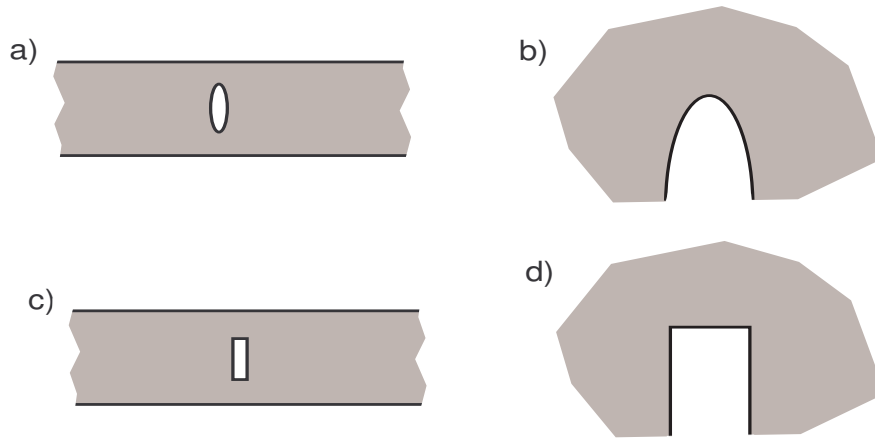

FIGURE 6.1. Ellipsoidal (a) and penny-shaped (b) screens having boundary layer effects. Scaled domains (c,d) for the description of the boundary layer.

fig5

sec6.3

6.2. Particular screens. We now discuss two examples which show that our assumption $\mathbf{3}^\circ$ means an essential simplification of calculations, since removing it would make the asymptotic analysis in Section 2.3 not valid. As was mentioned in Section 1.3 and follows from the sufficient condition (6.1), any submerged screen $\Theta^\varepsilon \subset \Pi$ traps a surface wave, with the exception of the case of a vertical planar screen. Let us discuss the boundary layer phenomenon for the flattened ellipsoid

$$\text{R2} \quad (6.2) \quad \Theta^\varepsilon = \{\mathbf{x} : R^{-2}(x_2^2 + (x_3 - z_0)^2) + \varepsilon^{-2}x_1^2 \leq 1\}$$

(cf. [30] for the much more simple two dimensional case) and for the penny-shaped obstacle

$$\text{R3} \quad (6.3) \quad \Theta^\varepsilon = \{\mathbf{x} : x_2^2 + (x_3 - z_0)^2 \leq R^2, |x_1| < \varepsilon\};$$

Both screens (6.2) and (6.3) are submerged and do not touch the wetted surface Σ of the channel Π , see Fig. 6.1.a,c.

The ellipsoid (6.2) is given by the formula (1.3), where θ is a disc of radius R and

$$\text{R4} \quad (6.4) \quad h_\pm(\mathbf{x}') = \sqrt{1 - R^{-2}(x_2^2 + (x_3 - z_0)^2)} = \sqrt{r}(R^{-1} + O(r)).$$

Since h_\pm vanish on the circle $\psi = \partial\theta$, all calculations of Section 2 can be repeated word-to-word to derive the asymptotic formula (2.1) for the single eigenvalue $\lambda^\varepsilon \in (0, \Lambda_\dagger)$ of (1.8)–(1.10). However, the decay rate $O(r^{1/2})$ in (6.4) is not enough to compensate the growth $O(r^{-3/2})$ of the second order derivatives of v , cf. the right hand side of (3.10). As a result, higher order terms cannot be found using the above presented asymptotic method. Indeed, it was shown in [9], see also [15], that the boundary layer phenomenon occurs in the vicinity of the edge $\Psi = \{\mathbf{x} : x_1 = 0, \rho := (x_2^2 + (x_3 - z_0)^2)^{1/2} = R\}$. Namely, dilating coordinates as

$$(x_1, \rho) \mapsto \xi = (\xi_1, \xi_2) = (\varepsilon^{-2}x_1, \varepsilon^{-2}(\rho - R)),$$

using the arc length $s \in [0, 2\pi R)$ on Ψ and setting $\varepsilon = 0$ lead to a Neumann problem for the two-dimensional Laplacian Δ_ξ in the plane \mathbb{R}^2 with parabolic notch

$$\mathbb{P} = \{\xi : \xi_2 < 0, |\xi_1| \leq (2|\xi_2|/R)^{1/2}\},$$

see Fig. 6.1.b. Detailed analysis of the boundary can be found in [9] and [15, Ch. 5].

For the penny-shaped screen (6.2) we have $h_\pm(\mathbf{x}') = 1$, and we come across a notable inconsistency in the previous calculations: the right hand side of (2.19) vanishes and the problem (2.13)–(2.16), (2.19) thus turns homogeneous, but according to (2.28), the coefficient b_1^1 in (2.23) takes the form (2.25) with $I(h) = 2\|\nabla' U_\dagger; L^2(\theta_r)\|^2$. This contradiction is of course caused by the boundary layer effect. Using the coordinate dilation

$$(x_1, \rho) \mapsto \xi = (\varepsilon^{-1}x_1, \varepsilon^{-1}(\rho - R)),$$

the effect is described by the solutions of the Neumann problem for Δ_ξ in the plane without the semi-strip

$$\mathbb{S} = \{\xi : \xi_2 \leq 0, |\xi_1| < 1\},$$

see Fig. 6.1.d. Indeed, the function $v_0(\mathbf{x}) = U_\dagger(\mathbf{x}')$ has the discrepancy $G(s) = \partial_r U_\dagger(\mathbf{x}')|_{r=R}$ in the Neumann condition on the lateral side of the circular cylinder (6.3). Therefore the main asymptotic term $\varepsilon W(\xi, s)$ of the boundary layer is to be chosen as a solution of the following problem with parameter s :

$$\begin{aligned} \boxed{\text{R5}} \quad (6.5) \quad & -\Delta_\xi W(\xi, s) = 0, \quad \xi \in \mathbb{S}, \\ & \mp \partial_1 W(\pm 1, \xi_2, s) = 0, \quad \xi_2 < 0, \\ & -\partial_2 W(\xi_1, 0, s) = G(s), \quad \xi_1 \in (-1, 1). \end{aligned}$$

Unfortunately, this problem has no solutions which decay at infinity. This is why we employ the traditional method of matched asymptotic expansions, see [29, 9] and change the essence of $\varepsilon W(\xi, s)$: it is regarded as a term in the inner expansion near the edge of the screen, and it is fixed as a solution of the problem (6.5) with logarithmic growth at infinity,

$$\boxed{\text{R6}} \quad (6.6) \quad W(\xi, s) = -\pi^{-1}G(s) \ln |\xi| + o(1), \quad |\xi| \rightarrow +\infty.$$

Now, (2.11) is regarded as the outer expansion in a neighbourhood of Θ^ε , and its term $\varepsilon v_1(\mathbf{x})$ must be subject to the asymptotic condition

$$(6.7) \quad v_1(\mathbf{x}) = -\pi^{-1}G(s) \ln r + O(1), \quad r \rightarrow +0.$$

This term thus becomes a nontrivial singular solution of the homogeneous problem (1.25)–(1.28). This explains why our calculations in Section 2.3 do not work for the penny-shaped screen. In other words, the assumption $\mathbf{3}^\circ$ simplifies calculations and removing it requires a different asymptotic analysis.

sec6.4

6.3. Surface-piercing screens. If the screen thickness function h does not vanish at the endpoints of the line segment $\phi = \partial\theta \cap \gamma$, then, yet another boundary layer must be taken into account, in addition to those discussed in Section 6.2. This amounts to solving a Neumann problem in the lower half-space with the infinite slit of width $h^0 = h_+^0 + h_-^0 > 0$,

$$\{\eta = (\eta_1, \eta_2, \eta_3) : \eta_3 < 0, \eta_2 < 0, \eta_1 \in [-h_-^0, h_+^0]\}.$$

The authors do not know published results in this direction. Another open question is related to the situation, when h is null on $\psi \setminus \bar{\tau}$ but positive on the arc $\tau = \{s : s \in (-t, t)\}$ of length $2t > 0$.

In addition to the assumption **3**^o we have required in Section 1.1 that the angle α between ψ and γ is right. We used this restriction in Section 3.3, since we needed the extension trick to study the singularities of v_2 . However, this assumption may be weakened: it was shown in [17] that the exponent β in the "worst" power-law solution (3.13) is a function, which decreases monotonely from 1 to 0, when the variable is the angle α measured from the side of θ . Thus, our calculations remain valid at least for acute angles.

REFERENCES

- AsRoVa** [1] Aslanyan, A., Parnovski, L., Vassiliev, D., Complex resonances in acoustic waveguides, *Quart. J.Mech. Appl.Math.* 53 (3) (2000), 429–447.
- BiSo** [2] Birman, M. Sh., Solomjak, M.Z., *Spectral theory of self-adjoint operators in Hilbert space*, D. Reidel, Boston, 1987.
- Bor1** [3] Bulla, W., Gesztesy, F., Renner, W., Simon, B., Weakly coupled bound states in quantum waveguides, *Proc. Amer. Math. Soc.* 125 (5) (1997), 1487–1495.
- Bor2** [4] Borisov, D.I., Discrete spectrum of an asymmetric pair of waveguides coupled through a window, *Mat. Sb.* 197 (4) (2006), 3–32. (English transl. *Sb.Math.* 197 (4)(2006), 475–504.)
- BBD** [5] Bonnet-Ben Dhia, A.-S., Joly, P., *Mathematical analysis of guided water waves*, *SIAM J. Appl. Math.*, 53 (1993), 1507–1550.
- EvLeVa** [6] Evans, D.V., Levitin M., Vassilev D., Existence theorems for trapped modes, *J. Fluid Mech.* 261 (1994), 21–31.
- Gad** [7] Gadylishin, R. R., On local perturbations of quantum waveguides, *Teoret. Mat. Fiz.*, 145 (3)(2005), 358–371. (English transl. *Theor. Math. Phys.* 145 (3) (2005), 1678–1690.)
- Gru** [8] Grushin, V. V., On the eigenvalues of a finitely perturbed Laplace operator in infinite cylindrical domains, *Mat. Zametki*, 75 (3) (2004), 360–371. (English transl. *Math. Notes*, 75(3) (2004), 331–340.)
- Ilin** [9] Ilin A.M., *Matching of asymptotic expansions of solutions of boundary-value problems*, Nauka, Moscow, 1989. (English transl. *Transl. Math. Monogr.*, vol. 102, Amer. Math. Soc., Providence, RI, 1992.)
- Kato** [10] Kato, T., *Perturbation theory of linear operators*, Springer-Verlag, Heidelberg, 1966; Mir, Moscow, 1972.
- Ko** [11] Kondratiev, V.A., Boundary value problems for elliptic problems in domains with conical or corner points, *Trudy Moskov. Matem. Obshch.* 16 (1967), 209–292. (English transl. *Trans. Moscow Math. Soc.* 16 (1967), 227–313.)
- McIver** [12] McIver, M., An example of non-uniqueness in the two-dimensional linear water wave problem, *J.Fluid Mech.* 315 (1996), 257–266.
- KuMaVa** [13] Kuznetsov, N., Maz'ya, V., Vainberg, B. *Linear water waves: a mathematical approach*, Cambridge University Press, 2002.
- LM** [14] Linton, C.M., McIver, P., Embedded trapped modes in water waves and acoustics, *Wave Motion* 45 (2007), 16–29.
- MaNaPl** [15] Maz'ya, V. G., Nazarov, S.A., Plamenevskii, B.A., *Asymptotische Theorie elliptischer Randwertaufgaben in singularär gestörten Gebieten I*, Akademie-Verlag, Berlin, 1991. (English transl. *Asymptotic theory of elliptic boundary value problems in singularly perturbed domains I*, Birkhäuser Verlag, Basel, 2000.)
- Me** [16] Meixner, J. Die Kantenbedingung in der Theorie der Beugung elektromagnetischer Wellen an vollkommen leitenden ebenen Schirmen. (German) *Ann. Physik* 6 (6) (1949), 2–9.
- na132** [17] Movchan, N.V., Nazarov, S.A., Asymptotics of singularity exponents at the tip of an angular crack, *Vestnik Leningrad. Univ.* 15 (1990), 34-38. (English transl. *Vestn. Leningr. Univ. Math.* 23 (3) (1990), 44-48.)

- na449** [18] Nazarov, S.A., Sufficient conditions for the existence of trapped modes in problems of the linear theory of surface waves, *Zap. Nauchn. Sem. St.-Petersburg Otdel. Mat. Inst. Steklov* 369 (2009), 202-223. (English transl. *Journal of Math. Sci.* 167 (5) (2010), 713-725).
- na457** [19] Nazarov, S.A., Variational and asymptotic methods for finding eigenvalues below the continuous spectrum threshold, *Sibirsk. Mat. Zh.* 51 (5) (2010), 1086-1101. (English transl. *Siberian Math. J.* 51 (5) (2010), 866-878.)
- na489** [20] Nazarov, S.A., Asymptotic expansions of eigenvalues in the continuous spectrum of a regularly perturbed quantum waveguide, *Theor. math. phys.* 167 (2) (2011), 239-262. (English transl. *Theor. math. phys.* 167 (2) (2011), 606-627)
- na510** [21] Nazarov, S.A., Enforced stability of an eigenvalue in the continuous spectrum of a waveguide with an obstacle, *Zh. Vychisl. Mat. i Mat. Fiz.* 52 (3) (2012), 521-538. (English transl. *Comput. Math. Math. Physics* 52 (3) (2012), 448-464.)
- na546** [22] Nazarov, S.A., Enforced stability of a simple eigenvalue in the continuous spectrum, *Funkt. Anal. i Prilozhen* 47 (3) (2013), 37-53. (English transl. *Funct. Anal. Appl.* 475 (3) (2013), 195-209.)
- NaPl** [23] Nazarov, S.A., Plamenevsky, B.A., *Elliptic Problems in Domains with Piecewise Smooth Boundaries*, Walter de Gruyter, Berlin New York, 1994.
- na436** [24] Nazarov, S.A., Taskinen, J., On essential and continuous spectra of the linearized water-wave problem in a finite pond, *Math. Scand.* 106 (2010), 141-160.
- na540** [25] Nazarov S.A., Taskinen J., Localization estimates for eigenfrequencies of waves trapped by a freely floating body in a channel, *SIAM J. Math. Anal.* 45 (4) (2013), 2523-2545.
- RS** [26] Reed, M., Simon, B., *Methods of modern mathematical physics*, M. Reed and B. Simon, *Methods of Modern Mathematical Physics, Vol. IV, Analysis of Operators*, Academic Press, New York San Francisco London, 1978.
- Ursell1** [27] Ursell, F., Trapping modes in the theory of surface waves, *Proc. Camb. Phil. Soc.* 47 (1951), 347-358.
- Ursell2** [28] Ursell F., Mathematical aspects of trapping modes in the theory of surface waves, *J. Fluid Mech.* 183 (1987), 421-437.
- VanDyke** [29] Van Dyke, M., *Perturbation Methods in Fluid Mechanics*, Academic Press, New York London, 1964; Mir, Moscow, 1967.
- na506** [30] Videman, J.H., Chiado Piat, V., Nazarov, S.A., Asymptotics of frequency of a surface wave trapped by a slightly inclined barrier in a liquid layer, *Zap. Nauchn. Sem. St.-Petersburg Otdel. Mat. Inst. Steklov* 393 (2011), 46-79. (English transl. *J. Math. Sci.* 185 (4) (2012), 536-553.)
- ViLu** [31] Vishik, M.I., Lyusternik, L.A., Regular degeneration and boundary layer for linear differential equations with small parameter, *Uspekhi Mat. Nauk* 12 (5) (1957), 3-122.

DIPARTIMENTO DI MATEMATICA, POLITECNICO DI TORINO, CORSO DUCA DEGLI ABRUZZI, 24, 10129 TORINO, ITALY

E-mail address: valeria.chiadopiat@polito.it

SAINT-PETERSBURG STATE UNIVERSITY, MATHEMATICS AND MECHANICS FACULTY, CHAIR OF ELASTICITY THEORY, UNIVERSITetskAYA NAB., 7-9, ST. PETERSBURG, 199034, RUSSIA, PETER THE GREAT SAINT-PETERSBURG STATE POLYTECHNICAL UNIVERSITY, LABORATORY "MECHANICS OF NEW NANO-MATERIALS", POLYTECHNICHESKAYA UL., 29, ST. PETERSBURG, 195251, RUSSIA, INSTITUTE OF PROBLEMS OF MECHANICAL ENGINEERING RAS, LABORATORY "MATHEMATICAL METHODS IN MECHANICS OF MATERIALS", V.O., BOLSHOJ PR., 61, ST. PETERSBURG, 199178, RUSSIA

E-mail address: s.nazarov@spbu.ru, srgnazarov@yahoo.co.uk

DEPARTMENT OF MATHEMATICS AND STATISTICS, P.O.BOX 68, UNIVERSITY OF HELSINKI, 00014 HELSINKI, FINLAND

E-mail address: jari.taskinen@helsinki.fi