



**ICOLD**  
Technical Committee A

---

# **14th International Benchmark Workshop on Numerical Analysis of Dams**

THEME B

**STATIC AND SEISMIC ANALYSIS OF AN ARCH-GRAVITY DAM**

Frédéric ANDRIAN., Pierre AGRESTI, Geoffrey  
MATHIEU  
**ARTELIA Eau & Environnement**



---

**DATE:** 6-8 SEPTEMBER 2017

## CONTENTS

|   |           |
|---|-----------|
| <b>1. INTRODUCTION</b>  | <b>1</b>  |
| <b>2. SPECIFIC BEHAVIOR OF ARCH-GRAVITY DAMS</b>  | <b>1</b>  |
| <b>3. GEOMETRY OF THE DAM</b>   | <b>2</b>  |
| <b>4. PROVIDED DATA</b>   | <b>4</b>  |
| <b>5. TYPES OF ANALYSES</b>   | <b>4</b>  |
| 5.1. CALCULATION PARAMETERS   | 4         |
| 5.2. SELFWEIGHT CALCULATION (*)   | 5         |
| 5.3. STATIC ANALYSES  | 5         |
| 5.3.1. Linear analysis (*)  | 7         |
| 5.3.2. Simplified non-linear analysis (*)   | 7         |
| 5.3.3. Non-linear analysis with propagation of uplift                                     | 7         |
| 5.4. SEISMIC ANALYSES   | 8         |
| 5.4.1. Linear pseudo-static analysis based on the site response spectrum acceleration (*) | 9         |
| 5.4.2. Linear time-history analysis with simplified dynamic interactions (*)              | 10        |
| 5.4.3. Non-Linear time-history analysis with simplified dam-reservoir interactions        | 11        |
| 5.4.4. Linear time-history analysis with advanced dynamic interactions                    | 11        |
| 5.4.5. Non-linear time-history analysis with advanced dynamic interactions                | 12        |
| <b>6. TIME FRAMEWORK</b>  | <b>13</b> |
| <b>7. REFERENCES</b>  | <b>13</b> |

## TABLES

|   |    |
|---|----|
| TABL. 1 - MAIN FEATURES OF THE JANNEH DAM | 2  |
| TABL. 2 - MATERIAL PROPERTIES             | 5  |
| TABL. 3 - SITE SPECTRUM ACCELERATIONS     | 10 |

## FIGURES

|   |    |
|---|----|
| FIG. 1. PLANE VIEW AND CROSS SECTION OF THE CENTRAL BLOCK OF THE JANNEH DAM   | 3  |
| FIG. 2. PLANE VIEW OF THE EXCAVATION OF THE JANNEH DAM                        | 3  |
| FIG. 3. 3D VIEW OF THE DAM  | 3  |
| FIG. 4. AREAS OF INTEGRATION OF STRESSES AT DAM / FOUNDATION INTERFACES       | 6  |
| FIG. 5. DISTRIBUTION OF UPLIFT ACROSS THE DAM                                 | 6  |
| FIG. 6. PATH OF THE CALCULATION OF THE OPENING AT DAM / FOUNDATION INTERFACE  | 7  |
| FIG. 7. MAXIMUM DISPLACEMENT AND ACCELERATION CALCULATION POINTS AT THE CREST | 8  |
| FIG. 8. MAXIMUM ARCH STRESS CALCULATION POINT                                 | 9  |
| FIG. 9. MAXIMUM VERTICAL STRESS CALCULATION POINTS                            | 9  |
| FIG. 10. SITE SPECTRUM OF ACCELERATIONS                                       | 10 |
| FIG. 11. POINTS FOR RESPONSE SPECTRA AND/OR HISTORIES OF ACCELERATIONS        | 11 |
| FIG. 12. LOCATION OF THE OUTCROP SIGNAL                                       | 12 |
| FIG. 13. HISTORIES OF SLIDING AND/OR OPENING POINTS                           | 13 |

# 1. INTRODUCTION

Under favorable conditions (shape of the valley, strength of the bedrock, availability of construction materials), the construction of an arch-gravity dam is a more and more interesting alternative.

More specifically, when Roller Compacted Concrete (RCC) is used, such alternative may be comparable to a Conventional Vibrated Concrete (CVC) arch dam in terms of costs of the project. Moreover, the higher overall thickness of the dam allows its construction on bedrocks of lower quality compared to that required for CVC arch dams.

There are several possible reasons which may induce the arching of the layout of a gravity dam:

- a) For hydraulic aspects: curving the spillway increases its discharge capacity;
- b) For seismic aspects: arching the dam prevents from an unacceptable sliding of the dam on its foundation;
- c) For the purpose of concrete saving: the downstream slope of an arch-gravity dam may be steeper than that of a straight gravity dam.

The case of the Janneh dam (157m high), under construction in Lebanon, refers to b) and c), subsequently.

The numerical simulation of this dam is proposed as the subject of the theme B of the 14<sup>th</sup> International Benchmark Workshop on Numerical Analysis of Dams.

# 2. SPECIFIC BEHAVIOR OF ARCH-GRAVITY DAMS

The behavior of straight gravity dams on wide valleys is rather well known and several international guidelines may be used in order to assist their design:

- The dam withstands the water pressure by means of shear strength at the dam/foundation interface and at several weak planes in the dam body and/or within the bedrock;
- Crack opening at the upstream toe is generally only allowed for unusual and extreme load cases.

Except for high-seismicity sites, 2D rigid block analysis is usually considered sufficient to assess the stability of such dams.

When the layout of a gravity dam is curved with a small enough radius of curvature referring to cases b) or c) mentioned earlier, arch effect is triggered, even under normal operating conditions.

The arch effect laterally transfers a part of the water pressure to the abutments of the dam. This leads to an offloading of the central blocks and an overloading of the bank blocks.

As a consequence:

- The overloaded bank blocks exhibits an opening at the upstream toe even for a usual load case (Normal Water Level);

- In addition to water pressure, the bank blocks are laterally loaded by the arch effect. Therefore, the bedrock excavation requires a specific geometry at this location in order to ensure a satisfactory stability against sliding.

Due to the opening at the upstream toe of the bank blocks, the grout curtain and the drainage gallery have to be moved back toward downstream in order to ensure their efficiency under static loads.

The converging geometry of the excavation prevents from any overall sliding toward downstream under the Safety Evaluation Earthquake (SEE). However, the dam and most of its appurtenant structures shall remain functional after the occurrence of the Operating Basis Earthquake (OBE).

### 3. GEOMETRY OF THE DAM

The Janneh dam is an arch-gravity RCC dam. The dam was initially designed as a straight-gravity dam. However, due to seismic reasons, its layout has been curved.

For the purpose of savings on concrete and excavation volume, the downstream toe of the dam has been vertically-truncated. Due to this feature, the 2D section of the central block does not satisfy the generally adopted stability criteria for straight gravity dams. The stability of the dam relies consequently on its 3D behavior.

The definition of the upstream and the downstream faces of the dam is cylindrical (simple curvature).

The dam is provided with an ungated overflow spillway at its crest.

The main features of the Janneh dam are provided in the following table.

**Tabl. 1 - Main features of the Janneh dam**

| Parameters                                  | Value        |
|---|--------------|
| Maximum height above excavation             | 157m         |
| Width at the crest                          | 10m          |
| Maximum width at the base                   | 66m approx.  |
| Crest length                                | 300m approx. |
| Radius of curvature of the upstream face    | 240m         |
| Elevation of the crest                      | 847m         |
| Elevation of the spillway                   | 839m         |
| Downstream slope from 831.2m down to 752.4m | 0.8H / 1V    |

The following figures provide with some views of the geometry of the dam.

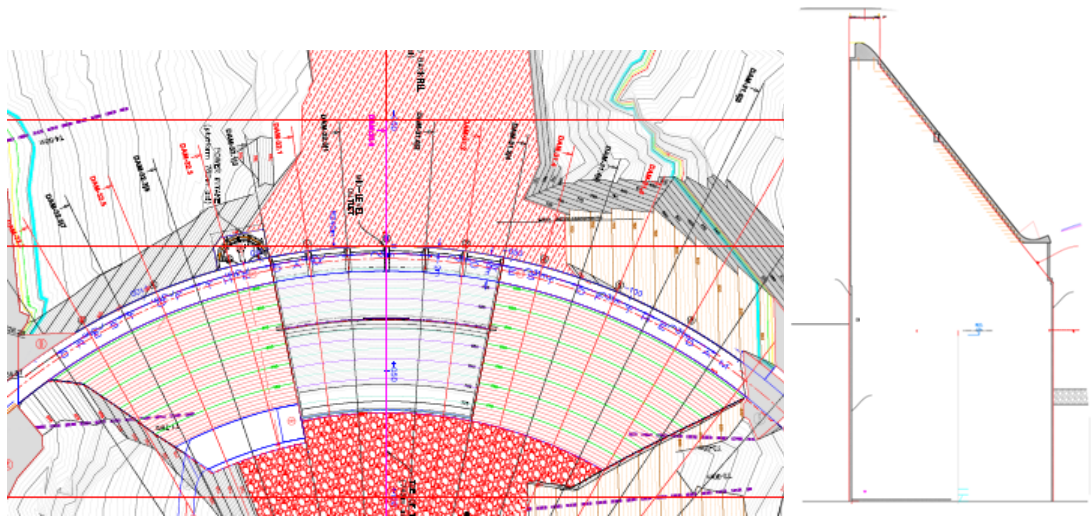

**Fig. 1. Plane view and cross section of the central block of the Janneh dam**

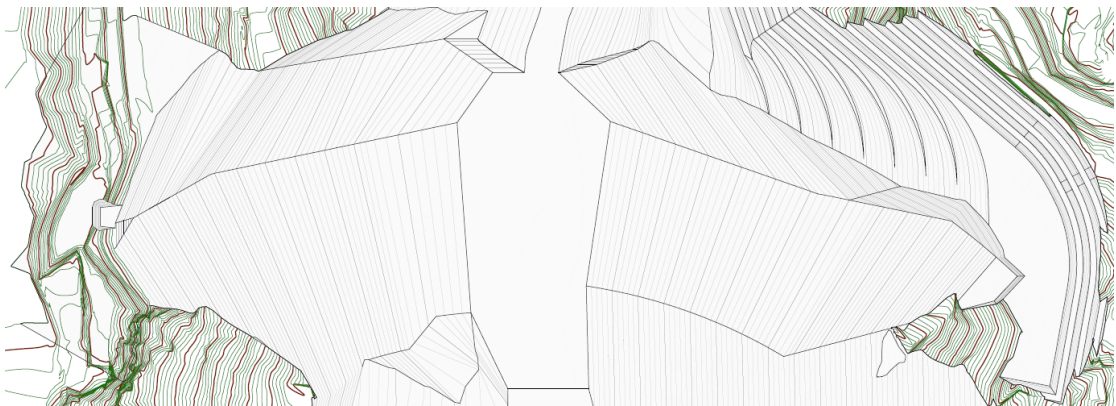

**Fig. 2. Plane view of the excavation of the Janneh dam**

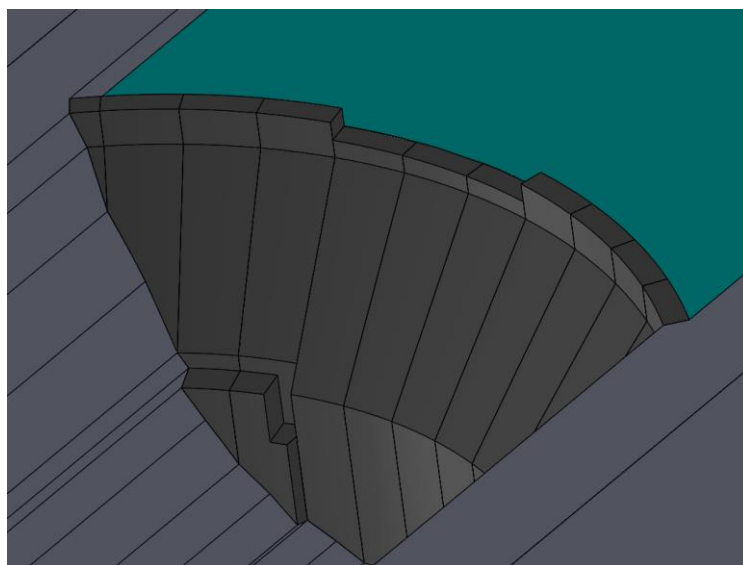

**Fig. 3. 3D view of the dam**

## 4. PROVIDED DATA

The following data are appended to this formulation document:

- 2 .dxf geometry files: one including the reservoir for the advanced dynamic interaction calculations. The origin of axes is located at the center of generation of the faces of the dam. X-axis is positive toward downstream whereas z-axis is positive upward;
- 2 .step geometry 3D files corresponding to the mentioned 2 geometries. **A scale factor x1000 needs to be applied to the .step geometries in order to get the dimensions of the model in meters;**
- 2 Ansys mesh files corresponding to the mentioned 2 geometries. The provided mesh files do not include interface elements;
- 2 sets of accelerograms (x+z): one for the simplified dynamic interaction and another one for the advanced dynamic interactions.

## 5. TYPES OF ANALYSES

The calculations to be carried out will follow a progressive approach: the subsequent stages are of increasing complexity.

The stages provided with (\*) are mandatory to report if participating to theme B.

The other stages are optional.

Every stage considers a model of the dam and its bedrock.

In order to simplify the calculations, the geometry, the water levels and the material properties specified in this formulation may be different from the real ones used in the design of the dam.

### 5.1. CALCULATION PARAMETERS

The concrete and the bedrock always follow a linear elastic constitutive law.

Depending on the calculation stage, the dam / foundation interface may follow a non-linear constitutive law. In such case, the interface elements will at least be able to model the opening at the dam / foundation interface. Ideally they will follow a Mohr-Coulomb constitutive law with a tension cut-off.

The main parameters of the model are summarized in the table below.

**Tabl. 2 - Material properties**

| Material                                | Density (kg/m <sup>3</sup> ) | Static deformation modulus (GPa) | Dynamic deformation modulus (GPa) | Poisson's ratio | p-wave velocity (m/s) | c (kPa) | φ (°) | Tensile strength (MPa) |
|---|------------------------------|----------------------------------|-----------------------------------|-----------------|-----------------------|---------|-------|------------------------|
| Concrete                                | 2400                         | 20                               | 30                                | 0.2             | -                     | -       | -     | -                      |
| Bedrock                                 | 2800 <sup>1</sup>            | 25                               | 30                                | 0.25            | -                     | -       | -     | -                      |
| Water                                   | 1000                         |                                  |                                   | 0.5             | 1414 <sup>2</sup>     | -       | -     | -                      |
| Dam / foundation interface <sup>3</sup> | -                            | -                                | -                                 | -               |                       | 0       | 45    | 0                      |

The stiffness parameters of the interface elements are to be defined by each participant.

## 5.2. SELFWEIGHT CALCULATION (\*)

Prior to any other stage, the participants are requested to carry out the selfweight calculation of the dam.

The dam is made of Roller Compacted Concrete (RCC). Therefore, the construction of the dam will be simulated by subsequently activating horizontal layers of approximately equivalent thickness. The construction of at least 10 subsequent layers will be simulated by the participants.

The construction stage will preferably consider a non-linear behavior of the dam / foundation interface as defined in Tabl. 2 - . However, the participants are allowed to consider the dam attached to its foundation if any numerical convergence issue is faced.

The requested results for each calculation stage described in this document are based on a model considering the combination of the selfweight calculation and the mentioned stage.

For the non-linear static analyses, the selfweight calculation shall be the initial state of the analysis.

At the end of the selfweight calculation, all the displacements of the model are reset to zero.

## 5.3. STATIC ANALYSES

The static analyses will be carried out for NWL at 839m. The downstream water level is considered at the bedrock level: 685m.

For each calculation stage, the mutual parameters to be provided by the participants for the static analyses are:

- The evolution of the upstream-to-downstream displacement of the upstream face of the central block B0 vs. elevation;
- The evolution of the upstream-to-downstream displacement of the upstream face of the bank block B5 vs. elevation;

<sup>1</sup> To be used when relevant. A massless foundation may be considered unless required by the calculation approach.

<sup>2</sup> To be used when the compressibility of water needs to be considered.

<sup>3</sup> To be used only for non-linear calculations.

- The evolution of the out-of-plane stress (also called hoop or arch stress) of the upstream face of the central block B0 vs. elevation;
- The resultant shear and normal forces (integration of stresses) at the dam / bedrock interface for the central block B0 and the bank block B5 (Fig. 4).

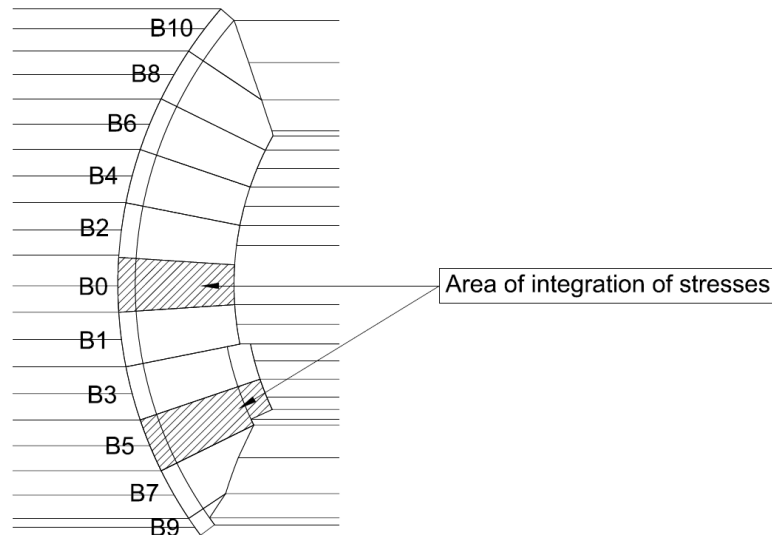
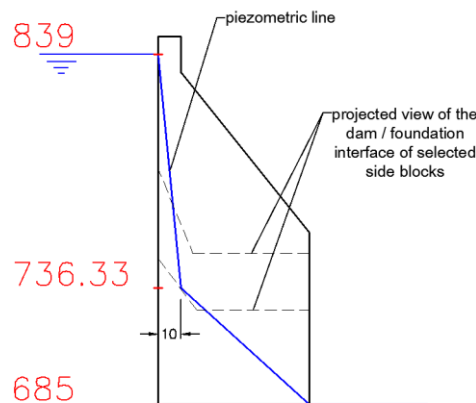

**Fig. 4. Areas of integration of stresses at dam / foundation interfaces**

Some parameters are also to be provided for specific stages. They are described in the paragraphs related to each stage.

Due to its thickness, the effect of uplift is significant on the stability of the dam.

The distribution of uplift is given in the following sketch.



**Fig. 5. Distribution of uplift across the dam**

A drainage efficiency equal to 1/3 is considered 10m behind the upstream face of the dam.

It is to be noted that as long as the line defining a cross section of the dam is coincident with the center of generation of the dam, this uplift distribution is relevant in the mentioned cross section.



The uplift is generally applied at the dam / foundation interface. When the piezometric line is located below the dam / foundation interface, the uplift to be applied is considered null.

### 5.3.1. Linear analysis (\*)

The linear analysis will consider the dam attached to its foundation. Each participant may choose whether to use or not interface elements at the dam / foundation interface. In any case, the used model shall behave as if the dam was attached to its foundation.

The participants are encouraged **not** to use the uplift distribution as external forces in the model for this stage. The uplift will only be subtracted to the resultant force as a post-treatment.

### 5.3.2. Simplified non-linear analysis (\*)

The simplified analysis will include interface elements at the dam / foundation interface. The uplift will be applied to the dam as external forces.

The interface elements will at least be able to model the opening at the dam / foundation interface. Ideally, they can follow a Mohr-Coulomb constitutive law with a tension cut-off.

The participants are also requested to provide with the evolution of the opening along a path at the dam / foundation interface of the joint between blocks B3 and B5 (Fig. 6).

The opening mentioned here refers to the normal relative displacement at the dam / foundation interface.

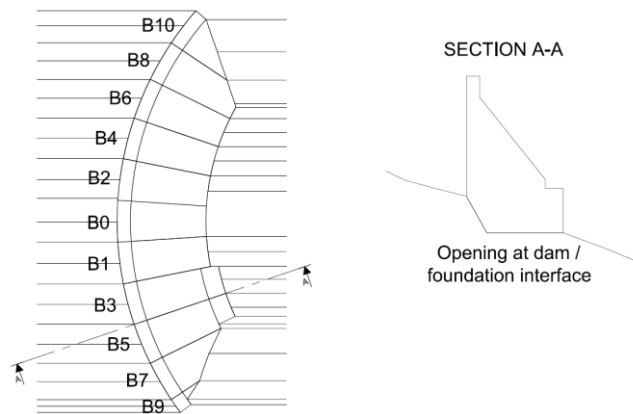

**Fig. 6. Path of the calculation of the opening at dam / foundation interface**

### 5.3.3. Non-linear analysis with propagation of uplift

This stage is basically the same as the previous one except the propagation of uplift is modeled at the opened region of the dam / foundation interface.

The formulators propose to apply a full uplift pressure at the opened regions of the interface but the participants are free to propose any other law that they believe to be relevant.

For this stage, the participants are also allowed to use the pore pressures as a variable of the model i.e. the calculations are carried out under effective stress state. The distribution of pore pressure within the dam body (and possibly the bedrock) then generates a heave which resultant is more or less equivalent to the uplift.

The participants are also requested to provide with the evolution of the opening along the same path as the one described in the previous stage (Fig. 6).

## 5.4. SEISMIC ANALYSES

The seismic analyses will be carried out for the OBE event. The PGA is 0.37g.

The water level to be considered is NWL at 839m.

The mutual parameters to be provided by the participants are as follows:

- The maximum upstream-to-downstream displacement at the crest of the central block B0 and at that of the bank block B5 (Fig. 7);
- The maximum vertical stress at two locations of the vertically-truncated toe of the central block (Fig. 9);
- The maximum out-of-plane stress (also called hoop or arch stress) at one location of the upstream face of the central block (Fig. 8).

Some parameters are also to be provided for specific stages. They are described in the paragraphs related to each stage.

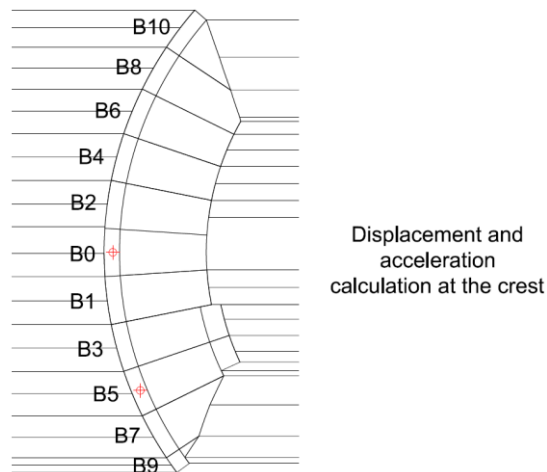

**Fig. 7. Maximum displacement and acceleration calculations points at the crest**

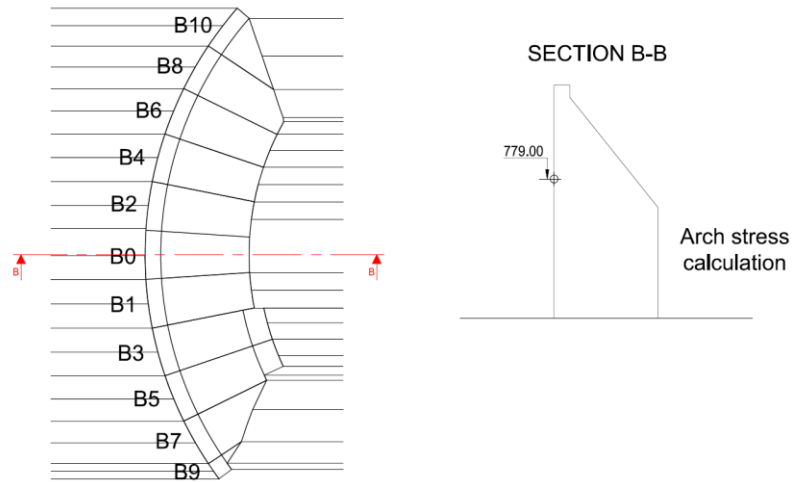

**Fig. 8. Maximum arch stress calculation point**

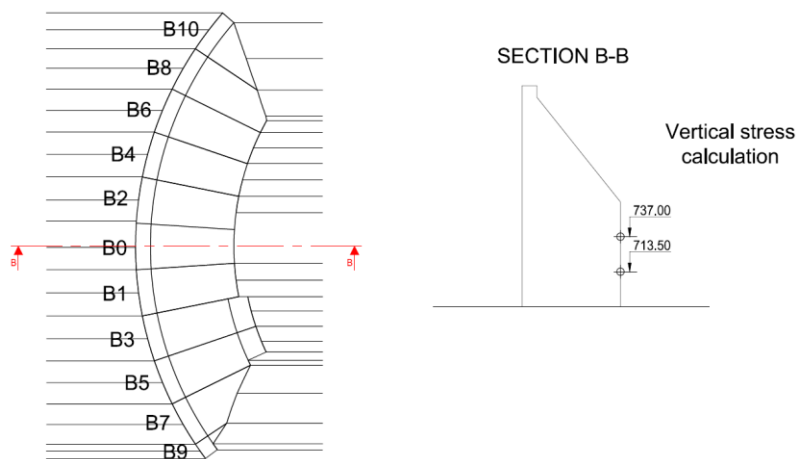

**Fig. 9. Maximum vertical stress calculation points**

#### 5.4.1. Linear pseudo-static analysis based on the site response spectrum acceleration (\*)

The calculations are based on a **non-linear** model conforming at least to the model used in the analysis described in 5.3.2 which results are considered as the initial state of the calculations.

The calculations will be carried out considering the following:

- The seismic inertia load is applied subsequently toward downstream and then toward upstream;
- The hydrodynamic pressure is calculated according to Westergaard's approach;
- When the seismic inertia load is applied toward upstream, so is the Westergaard's hydrodynamic pressure. The water static pressure is directed toward downstream;
- The foundation will be considered massless.

Prior to the pseudo-static analysis, an eigenvalue analysis will be carried out by the participants in order to assess the period and the modal mass of the 1<sup>st</sup> resonant mode of the system.

The seismic loads are calculated based on the site spectrum acceleration related to the 1<sup>st</sup> resonant mode of the system.

The site spectrum acceleration will be identified based on the site spectrum given in the following figure. The site spectrum is provided with a damping of 5%.

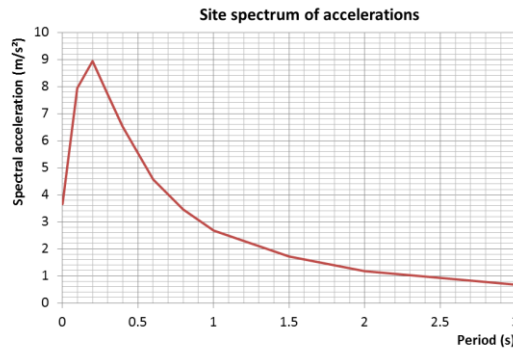

**Fig. 10. Site spectrum of accelerations**

**Tabl. 3 - Site spectrum accelerations**

| Period (s) | Acceleration (m/s <sup>2</sup> ) |
|------------|----------------------------------|
| 0.003      | 3.66                             |
| 0.1        | 7.95                             |
| 0.2        | 8.94                             |
| 0.3        | 7.71                             |
| 0.4        | 6.53                             |
| 0.6        | 4.57                             |
| 0.8        | 3.46                             |
| 1          | 2.68                             |
| 1.5        | 1.72                             |
| 2          | 1.18                             |
| 3          | 0.68                             |

#### 5.4.2. Linear time-history analysis with simplified dynamic interactions (\*)

The calculations are based on a linear model: the dam is attached to its foundation.

The participants will carry out a time history analysis. The input will be a set of accelerograms to be provided by the formulators.

For this calculation the following assumptions are to be adopted:

- The generalized Westergaard's added masses are to be used to simulate the fluid-structure interaction;
- The foundation will be considered massless;
- The damping to be used is 5% (dam and foundation).

The participants are free to choose the dynamic integration method. If the modal superimposition method is used, the considered modes will cumulate at least 85% of the total modal masses of the system in the upstream to downstream direction.

The participants are also encouraged to provide with the response spectra of accelerations calculated at the crest and at a mid-height elevation for the central block B0 and for the side block B5 (Fig. 11). At least, the participants will provide with the histories of calculated accelerations at the mentioned locations.

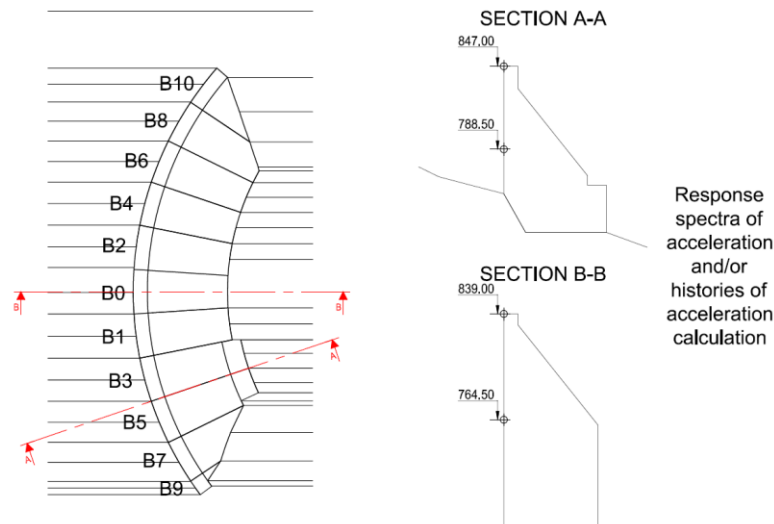

**Fig. 11. Points for response spectra and/or histories of accelerations**

#### **5.4.3. Non-Linear time-history analysis with simplified dam-reservoir interactions**

The calculations are basically the same as the one described in the previous stage except the calculations are based on a **non-linear** model. The model will conform at least to the one used in the analysis described in 5.3.2 which results are considered as the initial state of the calculations.

The uplift is considered steady during the seismic calculations.

#### **5.4.4. Linear time-history analysis with advanced dynamic interactions**

The calculations are basically the same as the one described in the previous stage except the assumptions related to dynamic interactions which are as follows:

- The compressibility of water will be considered in the approach used to simulate the fluid-structure interaction. The absorption of waves at the bottom of the reservoir is not considered. The approach will consider the reservoir of infinite length toward the upstream direction. The participants are encouraged to describe the used formulation;
- The foundation is provided with density and the boundary of the model can account of the radiation of outward waves toward the free-field domain. The participants are also encouraged to describe the used formulation;
- The considered material damping is 5% for the dam only. The foundation is not provided with material damping.

Due to the resolution of wave propagation in the foundation, the participants is provided with specific geometry/mesh and set of accelerograms to be applied at the bottom of the model. It is to be noted that the provided set of accelerograms is only relevant for the provided geometry of the foundation. Therefore, the participants shall not change the depth of the modeled foundation.

If the used method is based on boundary element method (sub-structuring method), the participants will use the same set of accelerograms provided for 5.4.2 as outcrop signal. The outcrop signal chosen here is the one measured at the downstream of the dam, at the bottom of the valley and on a free-field domain (Fig. 12).

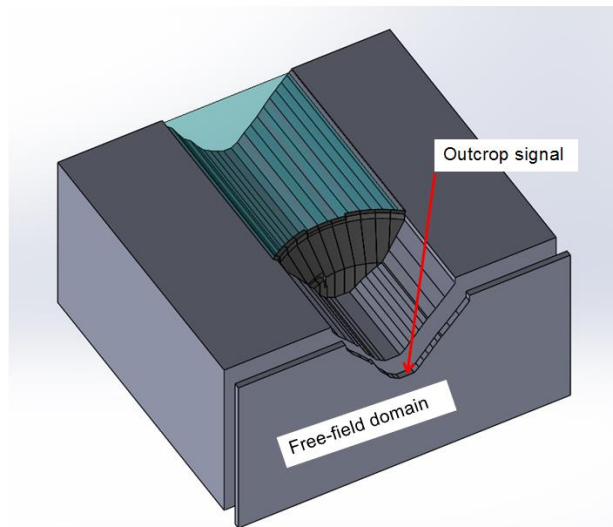

**Fig. 12. Location of the outcrop signal**

The participants are also encouraged to provide with the response spectra of accelerations calculated at the crest and at a mid-height elevation for the central block B0 and for the side block B5 (Fig. 11). At least the participants will provide with the histories of calculated accelerations at the mentioned locations.

#### **5.4.5. Non-linear time-history analysis with advanced dynamic interactions**

The calculations are based on the same assumptions as the previous stage except the dam / foundation interface follows a non-linear constitutive law.

The model will conform at least to the one used in the analysis described in 5.3.2 which results are considered as the initial state of the calculations.

The uplift is considered steady during the seismic calculations.

This constitutive law is at least able to allow the subsequent opening and closure of the interface. Ideally, the constitutive law will be Mohr-Coulomb with a tension cut-off.

The participants are also encouraged to provide with the response spectra of accelerations calculated at the crest and at a mid-height elevation for the central block B0 and for the side block B5 (Fig. 11). At least the participants will provide with the histories of calculated accelerations at the mentioned locations.

The participants will also provide with the histories of sliding and/or opening at the upstream and downstream toe of the central block B0 and of the bank block B5 (Fig. 13).

The sliding mentioned here is the tangential relative displacement at the dam / foundation interface

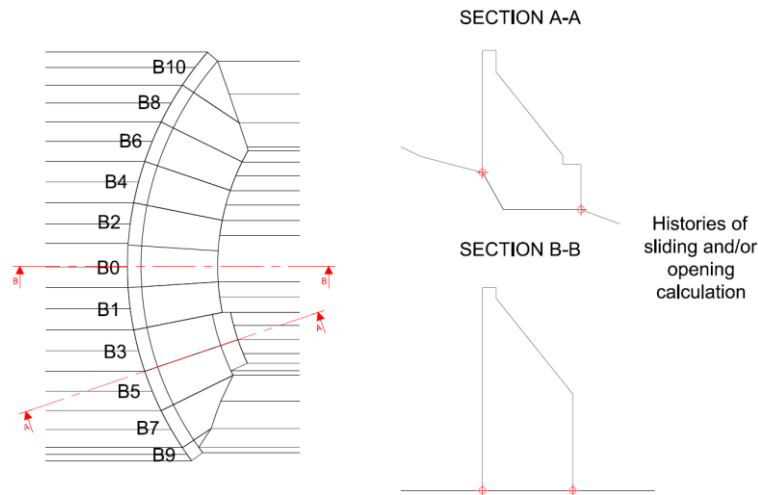

**Fig. 13. Histories of sliding and/or opening points**

## 6. TIME FRAMEWORK

The estimated time needed for the analyses is as follows:

- 5.2: 1 week (\*);
- 5.3.1: 1 week (\*);
- 5.3.2: 1 week (\*);
- 5.3.3: 2 weeks;
- 5.4.1: 1 week (\*);
- 5.4.2: 2 weeks (\*);
- 5.4.3: 2 weeks;
- 5.4.4: 2 weeks;
- 5.4.5: 2 weeks.

The mandatory parts will require about 6 weeks whereas the overall stages will require about 14 weeks.

## 7. REFERENCES

- Yziquel A., Andrian. F. and Agresti P., “Janneh dam Project – Non-linear simulation of an arch gravity dam”, Proceedings of the 13<sup>th</sup> International Benchmark Workshop on Numerical Analysis of Dams, Lausanne, Switzerland, October 2015;

- Andrian. F., "Effects of radiative boundary conditions on seismic analysis of gravity dams", Presentation at the International Symposium – Qualification of dynamic analyses of dams and their equipments and of probabilistic assessment seismic hazard in Europe, St-Malo, France, Septembre 2016.

oOo