

14th International Benchmark Workshop on Numerical Analysis of Dams

Original

14th International Benchmark Workshop on Numerical Analysis of Dams / Valente, Silvio; Chiara, Capriulo. -
ELETTRONICO. - (2017). (Intervento presentato al convegno 14th International Benchmark Workshop on Numerical
Analysis of Dams tenutosi a Stockholm(SE) nel 6-8 september 2017).

Availability:

This version is available at: 11583/2686448 since: 2017-10-16T17:33:09Z

Publisher:

KTH literature database (<http://kth.diva-portal.org/>)

Published

DOI:

Terms of use:

This article is made available under terms and conditions as specified in the corresponding bibliographic description in
the repository

Publisher copyright

(Article begins on next page)

ICOLD 14th International Benchmark Workshop on Numerical Analysis of Dams

Theme B: Static and seismic analysis of an arch gravity dam

Valente S.¹ and Capriulo C.¹

¹*Politecnico di Torino, Department of Structural, Geotechnical and Building Engineering (DISEG), Turin, ITALY*

E-mail: silvio.valente@polito.it

ABSTRACT: The Janneh dam is a 162-meter high Roller Compacted Concrete arch-gravity dam under construction in the Nahr Ibrahim Valley of Lebanon. The impounded reservoir will supply water, irrigate agricultural areas and generate hydropower [1]. The dam will serve the Northern areas of Greater Beirut Mount Lebanon [2]. The project site is located in high-seismicity region. The Peak Ground Accelerations are 0.37g and 0.51g respectively for OBE and SEE. Under favorable conditions (shape of the valley, strength of the bedrock, availability of construction materials), the construction of an arch-gravity dam is a more and more interesting alternative. The construction stages are simulated in ABAQUS environment in order to perform both linear and non-linear analyses.

1 Introduction

The reservoir, with a catchment area of some 242 km², extends for 3.2 km upstream from the dam and is expected to contain 37 Mm³ of water [2]. The resulting arch-gravity dam behaves differently from both straight gravity and arch dams. For thick dams, arch effect generates openings at the dam/foundation interface [1].

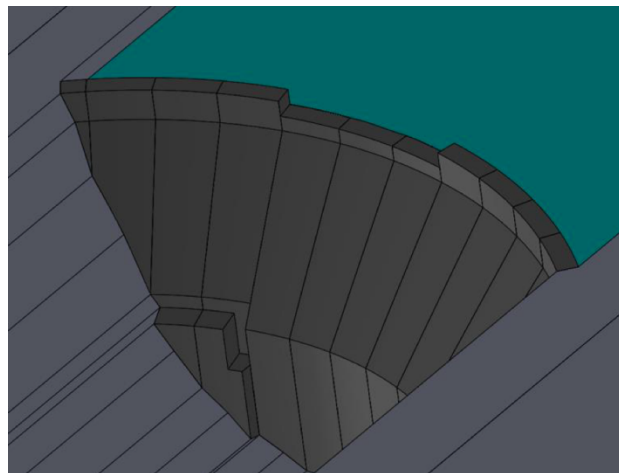

Figure 1: 3D view of the dam [3]

Current approach for the earthquake resistant design of dams relies on the “performance based design” based on the guidelines of the Committee on Seismic Aspects of Dam Design of the International Commission on Large Dams (ICOLD, 2010).

2 Behavior of arch-gravity dams

The behavior of straight gravity dams on wide valleys is rather well known and several international guidelines may be used in order to assist their design:

- The dam withstands the water pressure by means of shear strength at the dam/foundation interface.

When the layout of a gravity dam is curved with a small enough radius of curvature, arch effect is triggered, even under normal operating conditions. The arch effect transfers a part of the water pressure to the abutments of the dam laterally. This leads to the offloading of the central blocks and the overloading of the bank blocks. As a consequence:

- The overloaded bank blocks exhibit an opening at the upstream toe even for a usual load case (Normal Water Level);
- In addition to water pressure, the bank blocks are loaded by the arch effect laterally. Therefore, the bedrock excavation requires a specific geometry at this location in order to ensure a satisfactory stability against sliding.

Due to the opening at the upstream toe of the bank blocks, the grout curtain and the drainage gallery have to be moved back toward downstream in order to ensure their efficiency under static loads. The converging geometry of the excavation prevents from any overall sliding toward downstream under the Safety Evaluation Earthquake (SEE). However, the dam and most of its appurtenant structures will remain functional after the occurrence of the Operating Basis Earthquake (OBE).

3 Geometry of the dam

The Janneh dam is an arch-gravity RCC dam. The dam has been designed curved due to seismic reasons. The definition of the upstream and the downstream faces of the dam is cylindrical (simple curvature). The downstream toe of the dam has been vertically-truncated. The 2D section of the central block does not satisfy the stability criteria for straight gravity dams generally adopted. The stability of the dam relies consequently on its 3D behavior.

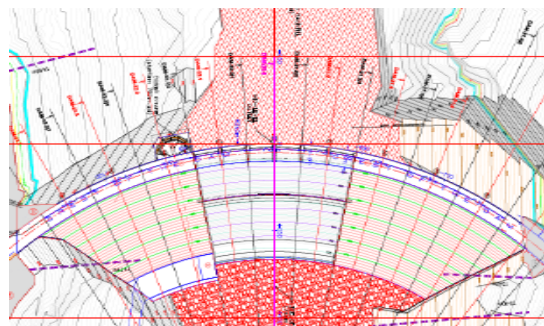

figure 2: Plane view of Janneh dam

Parameters	Value
Maximum height above excavation	157m
Width at the crest	10 m
Maximum width at the base	66 m approx
Crest length	300 m approx.
Radius of curvature of the upstream face	240 m
Elevation of the crest	847 m
Elevation of the spillway	839 m
Downstream slope from 831.2m down to 752.4m	0.8H/1V

Table 1: Main features of the Janneh dam

4 Calculation parameters

The main parameters of the model are summarized in the table below.

Material	Density (kg/m ³)	Static deformation modulus (GPa)	Dynamic deformation modulus (GPa)	Poisson's ratio	c (kPa)	φ (°)	Tensile strength (MPa)
Concrete	2400	20	30	0.2	-	-	-
Bedrock	2800	25	30	0.25	-	-	-
Water	1000			0.5	-	-	-
Dam / foundation interface	-	-	-	-	0	45	0

Table 2: Material parameters used for the modeling

5 Self-weight calculation

The analysis of self-weight calculation is mandatory for high arch dams made of Roller Compacted Concrete (RCC). Moreover, the downstream slope of Janneh dam is steeper than that one of a straight gravity dam, which makes it more sensitive to sequential changes of structural system during construction. In this study, a time step of 56 days is used to simulate each of the 10 approximated layers of construction. The relationship of time dependent strain model $\varepsilon(t)$ due to the varying load scheme is given by [1]:

$$\varepsilon(t) = \varepsilon_{el}(t) + \varepsilon_c(t) \quad (1)$$

The elastic strain $\varepsilon_{el}(t)$ is:

$$\varepsilon_{el}(t) = \frac{\sigma(t)}{E_{cm}} \quad (2)$$

Where $E_{cm} = 30 \text{ GPa}$ is given by [3] and $\sigma(t)$ is the stress history given by the load due to the layer construction stages. According to the formulation text, the thermal effects and shrinkage are neglected. Under a constant σ_c the creep strain ε_c evolves as follows:

$$\varepsilon_c(t - t_0) = \frac{\sigma_c}{E_{cm}} \varphi(t - t_0) \quad (14)$$

Where $\varphi(t - t_0)$ is given according to eq. 5.1-71a [4]:

$$\varphi(t - t_0) = \varphi_u \left[\frac{t - t_0}{350 + (t - t_0)} \right]^{0.3}$$

For the standard conditions, in the absence of specific creep data for local aggregates and conditions, the average value proposed for the ultimate creep coefficient φ_u is 2.35 according eq. (A-19) [5]. The principle of superposition is assumed to be valid and the numerical viscoelastic model [6] uses a Prony series representation of creep data according to [4].

6 Static analysis

The static analysis of this arch dam is carried out for self-weight and hydrostatic pressure of the impounded water at NWL at 839m. The downstream water level is considered at the bedrock level: 690m. More details are included in results and survey files attached.

6.1 Linear analysis

The linear static analysis considers the dam attached to its foundation without uplift distribution applied as external forces. The hydrostatic water pressure is considered as a surface load applied according to the normal vector of the local boundary system. It is relevant the knowledge of the upstream-to-downstream displacement of the upstream face of the central block B0 and bank block B5 vs. elevation. The evolution of the upstream-to-downstream displacement of the upstream face of the central block B0 vs. elevation is given in the following figure 3.

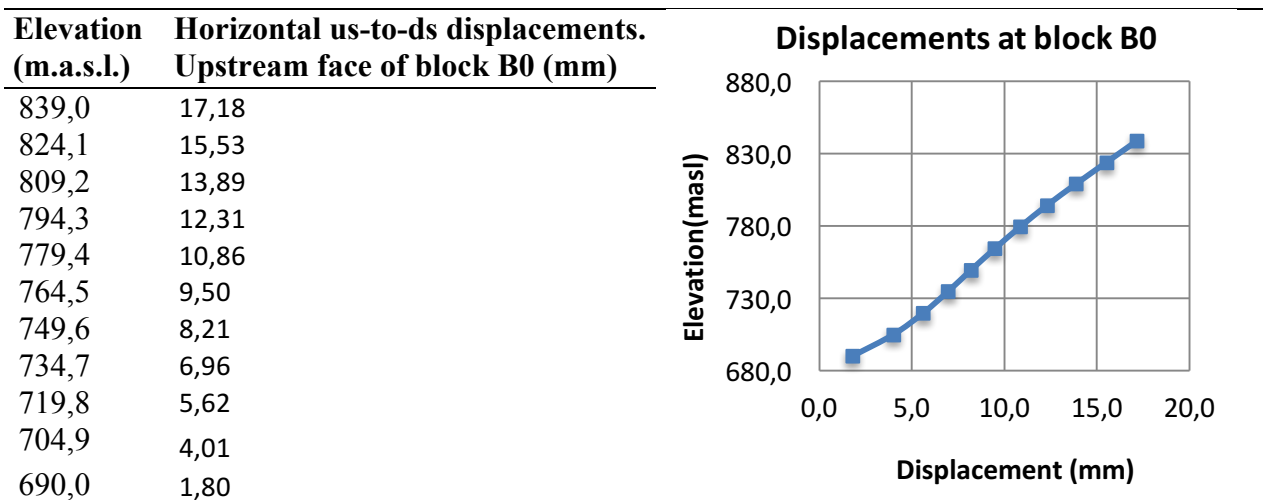

Figure 3: Horizontal us-to-ds displacement at block B0

The evolution of the upstream-to-downstream displacement of the upstream face of the bank block B5 vs. elevation is given in the following figure 4.

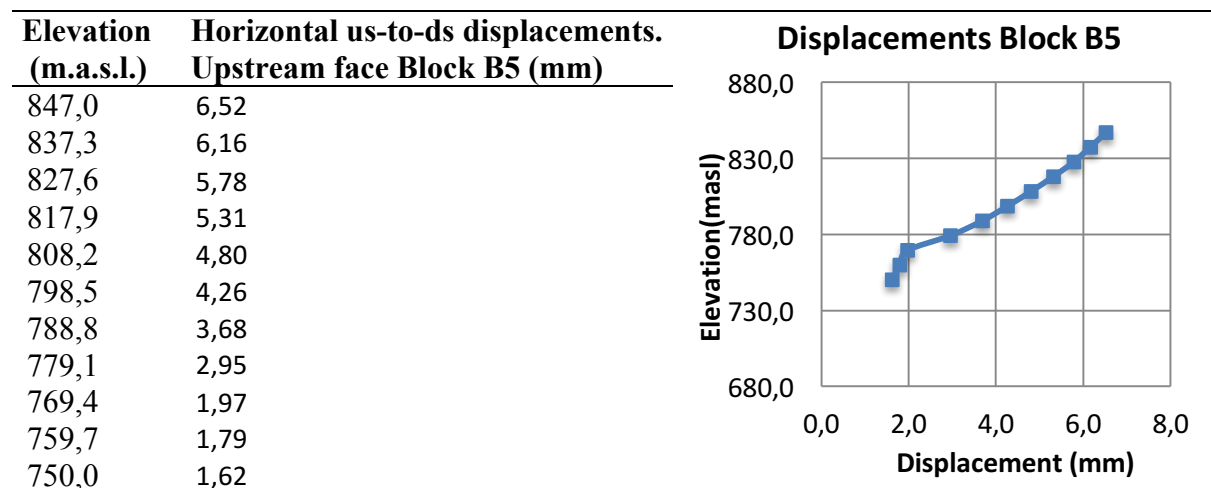

Figure 4: Horizontal us-to-ds displacement at block B5

The evolution of the out-of-plane stress (also called hoop or arch stress) of the upstream face of the central block B0 vs. elevation is given in following figure 5.

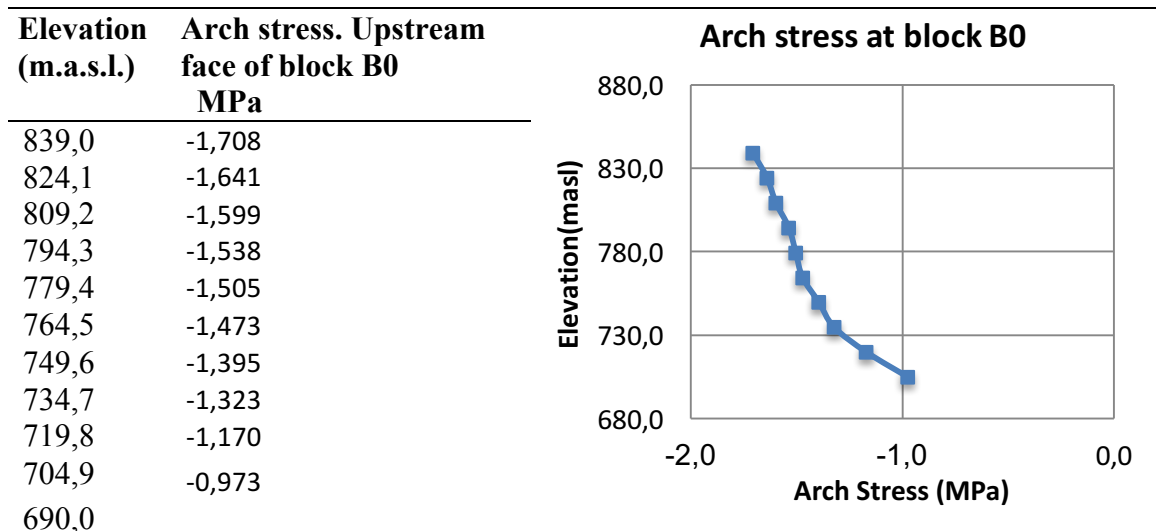

Figure 5: Arch stress. Upstream face at block B0

Starting by the self-weight model, it is important to evaluate the arch and cantilever stresses in the areas shown in figure 6. The resultant shear and normal forces at the dam / bedrock interface for the central block B0 and the bank block B5 are given in the following figure 6.

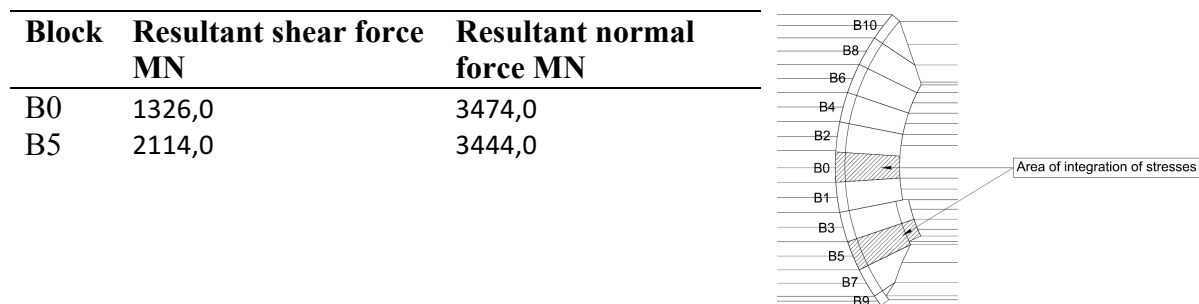

Figure 6: The resultant shear and normal forces

6.2 Simplified non-linear analysis

At the dam / foundation interface a node-to-surface contact problem is solved. When the slip displacement is smaller than 0.2 mm, an elastic interaction is applied. Otherwise the friction force follows the Coulomb's law. The uplift is applied to the dam as external forces.

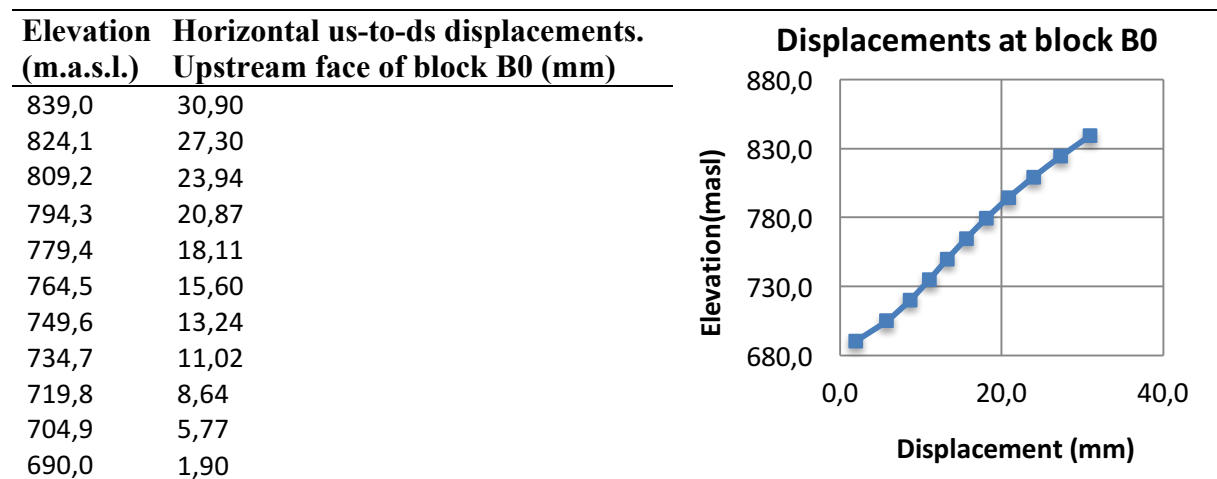

Figure 7: Representation horizontal us-to-ds displacements upstream face of block B0 (mm)

Displacements shown in figure 7 are computed using a viscoelastic material model, neglecting the aging of concrete and assuming $t = \infty$. A purely elastic model gives smaller displacements.

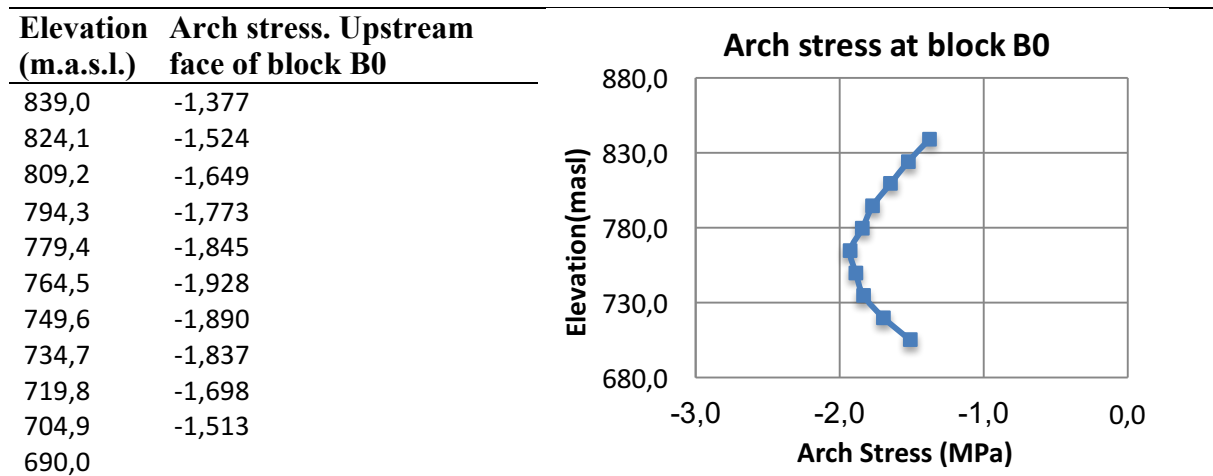

Figure 8: Representation arch stress upstream face at block B0

The resultant shear and normal forces at the dam / bedrock interface for the central block B0 and the bank block B5 taking into account the uplift pressure are given in the next table 9.

Block	Resultant shear force MN	Resultant normal force MN
B0	1510,0	4363,0
B5	2090,0	3388,0

Table 9: The resultant shear and normal forces taking into account the uplift pressure

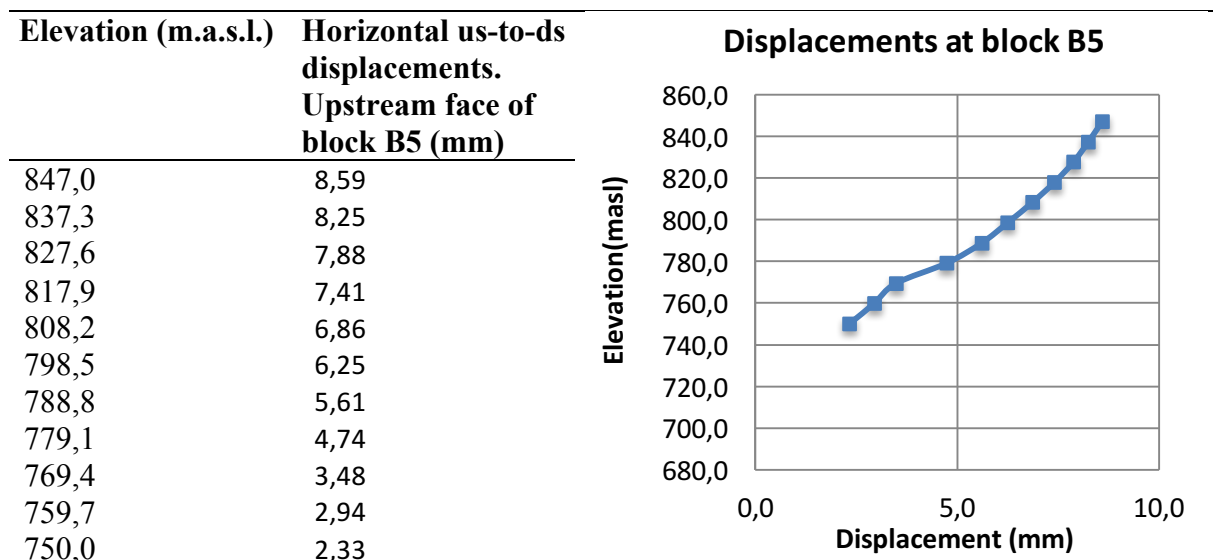

Figure 9: Representation arch stress upstream face of block B5

In this case, it is important to study the evolution of the opening along a path at the dam / foundation interface of the joint between blocks B3 and B5 as shown in the figures 10 and 11:



Figure 10: Path of the calculation of the opening at dam/foundation interface

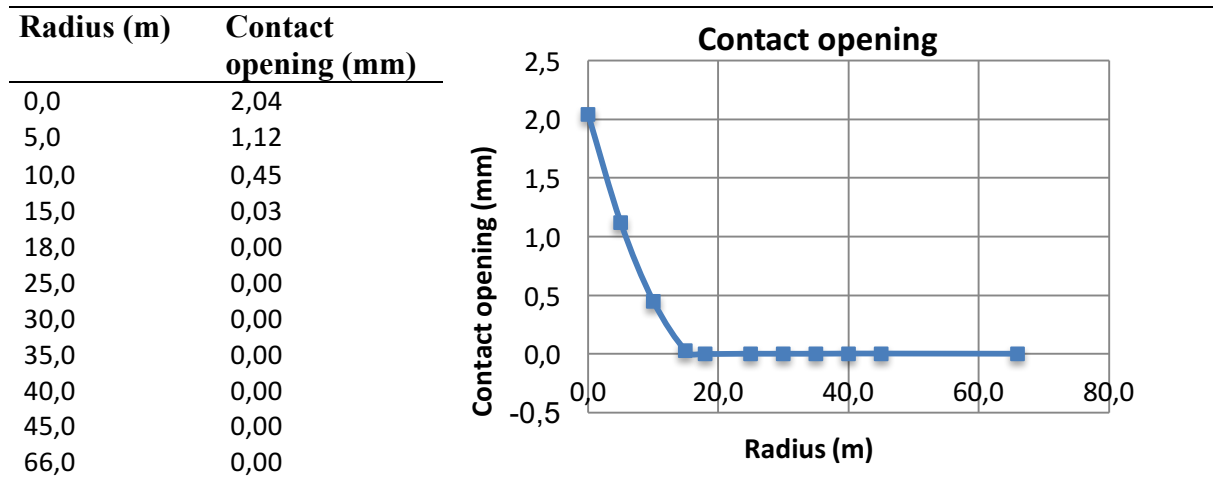

Figure 11: Representation of contact opening (mm) at dam/foundation interface

7 Seismic analysis

The earthquake response of an arch dam is influenced by its dynamic interaction with its deformable foundation rock and the impounded water [9]. The seismic analyses is carried out for the OBE event. The PGA is 0.37g. The water level to be considered is NWL at 839m.

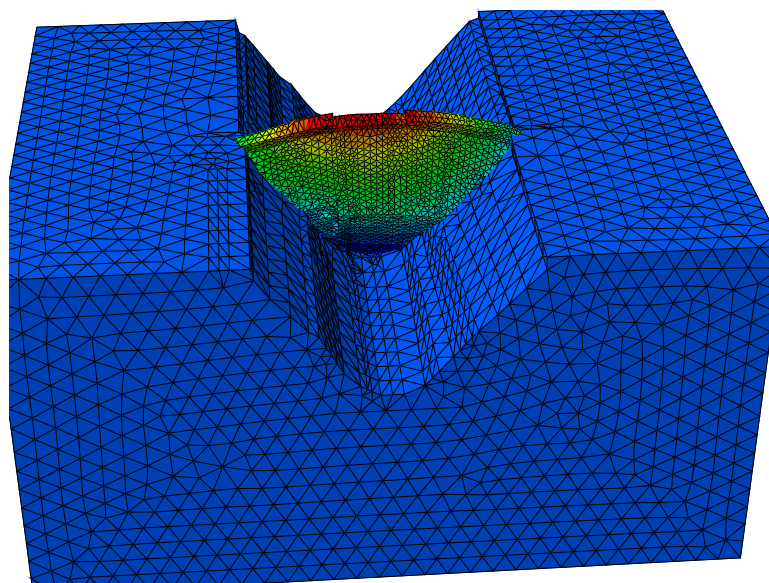

Figure 12: 1st eigenmode of linear model

7.1 Non-Linear pseudo-static analysis based on the site response spectrum acceleration

The calculations are based on a non-linear model conforming to the model described in previous section 6.2 whose results are considered as the initial state of the calculations. The calculations are carried out considering the following:

- The seismic inertia load is applied subsequently toward downstream and then toward upstream;
- The hydrodynamic pressure is calculated according to Westergaard's approach;
- When the seismic inertia load is applied toward upstream, so is the Westergaard's hydrodynamic pressure. The water static pressure is directed toward downstream;
- The foundation is considered massless.

The 1st eigenmode period is 0.39 (s) and its modal mass is equal to 57.8 % of total mass. According to the response spectrum given by the formulators, the related pseudo-acceleration is 6.65 m/s^2 .

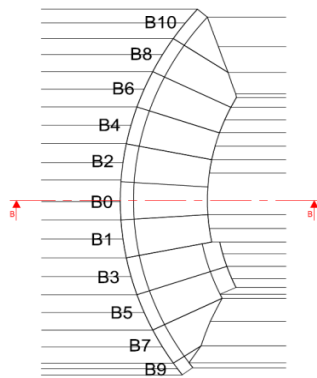

Figure 13: Section B-B

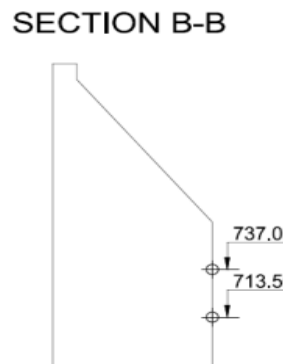

Figure 14: Maximum vertical stress calculation points

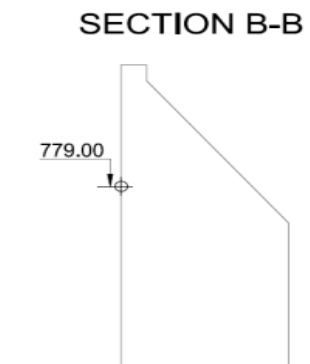

Figure 15: Maximum arch stress calculation point

Block	Maximum horizontal us-to-ds displacement at the crest	
	Inertia towards downstream (mm)	Inertia towards upstream (mm)
B0	79,0	-31,0
B5	33,7	-43,8

Table 13: Maximum horizontal us-to-ds displacement at the crest

Elevation m.a.s.l.	Maximum vertical stress at B0	
	Inertia towards downstream (MPa)	Inertia towards upstream (MPa)
737,0	-0,820	0,820
713,5	-1,900	1,250

Table 14: Maximum vertical stress at B0

Elevation m.a.s.l.	Maximum arch stress at B0	
	Inertia towards downstream (mm)	Inertia towards upstream (mm)
779,0	-5.5	0.6

Table 15: Maximum arch stress at B0

7.2 Linear time-history analysis with simplified dynamic interactions

The calculations are based on a linear model: the dam is attached to its foundation. The input is a set of accelerograms provided by the formulators. The generalized Westergaard's added masses [7,8] are used to simulate the fluid-structure interaction. The foundation is considered massless and the damping parameter is equal to 5% (dam and foundation).

The added masses are x-directed. The seismic analyses are carried out for the OBE event. The model superposition method is based on the first 12 modes shown in table 16. The considered modes cumulate, in x-direction, 93% of the total mass.

Mode	1	2	3	4	5	6	7	8	9	10	11	12
Eigenfrequency (cycle/s)	2.87	4.16	5.30	5.7	6.70	6.91	6.97	7.60	8.53	8.83	9.78	9.93
Modal mass %	54.0	0.00	4.19	25.7	0.00	0.00	0.01	0.00	0.14	0.84	0.05	8.05

Table 16: Eigenmodes used in the model superposition method

Block	Maximum horizontal us-to-ds displacement at the crest
	Inertia towards downstream (mm)
B0	42,0
B5	13,4

Table 17: The maximum upstream-to-downstream displacement at the crest of the central block B0 and at that of the bank block B5

Elevation m.a.s.l.	Maximum tensile vertical stress at B0 (MPa)
737,0	0,90
713,5	0,75

Table 18: The maximum tensile vertical stress at two locations of the vertically-truncated toe of B0

Elevation m.a.s.l.	Maximum compressive arch stress at B0 (MPa)
779,0	-1,00

Table 19: Maximum compressive arch stress at B0

Elevation m.a.s.l.	Maximum tensile arch stress at B0 (MPa)
839,0	4,70

Table 20: Maximum tensile arch stress at the crest of B0

8 Conclusions

The results presented show a transition between two mechanical regimes: the first one is purely elastic, when the dam is attached to its foundation, the second one is characterized by contact with friction.

From a physical point of view the above mentioned transition probably occurs when the reservoir is filled up for the first time.

From a numerical point of view two independent models are considered starting from the first stage of the dam construction.

When the classical Newton-Raphson method is applied to the second regime a loss of convergence sometimes occurs [10] due to a large number of sticking-to-slipping transitions. In order to reduce this phenomenon, when the slipping displacement is less 0.2 mm, an elastic interaction is considered.

Further details on the mechanical hypothesis assumed are described in the formulation text [3] and in two documents related to our contribution: the survey.xlsx and results.xlsx.

9 Acknowledgment

The support of the Italian Super Computing Resource Allocation of CINECA, through the Grant IsC49_icold_bw, is gratefully acknowledged.

10 References

- [1] Yziquel, F. Andrian and P. Agresti (2015). “13th ICOLD International Benchmark Workshop on Numerical Analysis of Dams, Janneh dam Project – Non linear numerical simulation of an arch-gravity dam”.
- [2] Greater Beirut - Water supply augmentation project - Environmental and social impact - Assessment (2014). Final ESIA Vol. 1, Beirut, Liban.
- [3] 14th ICOLD BMW theme B formulation FINAL 2.
- [4] International Federation for Structural Concrete (2010). CEB-FIP Model Code of Concrete Structures, Berlin, Germany.
- [5] American Concrete Institute Committee 209 (2008). Guide for Modelling and Calculating Shrinkage and Creep in Hardened Concrete, Report 209.2R-08. Farmington Hills, MI.
- [6] Simulia ABAQUS version 6.14.
- [7] U.S. Army Corps of Engineers (1993). Theoretical Manual for Analysis of Arch Dams, Technical Report ITL-93-1, Emeryville, CA.
- [8] U.S. Army Corps of Engineers (2003). Time-History Dynamic Analysis of Concrete Hydraulic Structures, EM No. 1110-2-6051, Washington, DC.
- [9] Chopra A. (2012). Dynamic of structures, Fourth edition: Theory and Applications to Earthquake Engineering. Prentice Hall.
- [10] Valente S., Alberto A., Barpi F. (2016). A large time increment method applied to an interface cohesive crack growing in compression-shear conditions. Engineering fracture mechanics, DOI: [dx.doi.org/10.1016/j.engfracmech.2016.04.019](https://doi.org/10.1016/j.engfracmech.2016.04.019).