

Calibration system for low-current transresistance amplifiers with a low-frequency sinewave source

Original

Calibration system for low-current transresistance amplifiers with a low-frequency sinewave source / Finardi, Ilaria; Callegaro, Luca. - STAMPA. - (2017). (XXXIInd General Assembly & Scientific Symposium Montreal, Canada 19-26 Agosto 2017).

Availability:

This version is available at: 11583/2681651 since: 2017-09-22T13:35:17Z

Publisher:

URSI Union Radio-Scientifique Internationale

Published

DOI:

Terms of use:

This article is made available under terms and conditions as specified in the corresponding bibliographic description in the repository

Publisher copyright

(Article begins on next page)

Calibration system for low-current transresistance amplifiers with a low-frequency sinewave source

Ilaria Finardi⁽¹⁾⁽²⁾ and Luca Callegaro⁽¹⁾

(1) INRIM - Istituto Nazionale di Ricerca Metrologica, Strada delle Cacce 91, Torino, Italy, Email: i.finardi@inrim.it

(2) Politecnico di Torino, Corso Duca degli Abruzzi 24, 10129 Torino, Italy

Abstract

The calibration of the transresistance gain of low-current dc amplifiers can be performed with the capacitance-charging method, where the calibration current is generated by a calibrated voltage ramp applied to a reference capacitor. The method is typically implemented with a purposely-built voltage source having a very low-frequency trapezoidal periodic waveform output. Here we propose a variation of the method based on a sinusoidal excitation, that can be provided by a commercial oscillator and therefore more easily implemented. Sampled sinusoidal input and output are processed with a seven-parameter sine-fitting algorithm. The comparison between calibration with sinusoidal and trapezoidal excitations is ongoing and will be presented at the Conference.

1 Introduction

In the following, we present a calibration system for low-current transresistance amplifier based on the capacitance-charging method [1–5]. The calibrating current is the displacement current of a gas-dielectric capacitor C generated by a time-varying voltage $v(t)$. The nominal currents generated are typically in the range 100 fA to 100 pA, with uncertainties down to parts in 10^5 . Typically, the $v(t)$ chosen waveform has a trapezoidal shape, composed of two linear ramps and two constant voltage sections: hence, a periodic sequence of constant current values $+I, 0, -I, 0, \dots$ is available as source output.

The capacitance-charging method is employed for the calibration of low-current meters [1–4], where the quantity being calibrated is the (adimensional) gain, close to unity, of the displayed current reading versus the excitation current. Recently, we proposed an implementation of the method for the calibration of low-current amplifiers [5], where the quantity to be calibrated was the transresistance gain R expressed in Ω .

An inconvenience of the choice of the trapezoidal-shaped waveform for $v(t)$ is that it requires a voltage source realized for purpose, since commercial generators are not available.

We here propose a variation of our calibration setup for transresistance amplifiers [5] that employs a low-frequency

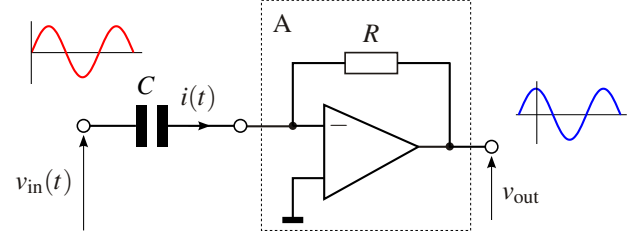

Figure 1. Principle schematics of the capacitance-charging method. The test current $i(t)$ is generated by the application of a voltage $v_{in}(t)$ to a capacitor C ; the amplifier A under calibration, having transresistance R , outputs the voltage $v_{out}(t)$.

sinusoidal waveform $v(t)$, generated by a commercial source. The signals involved are asynchronously sampled by two multimeters. The new setup, not employing purposely-built instrumentation, can be easily replicated in electronic or physics laboratories which require accurate measurement of low currents, such as those working on single-electron experiments (see e.g. [6, 7]).

2 The capacitance-charging method

In the capacitance-charging method (see Fig. 1) a voltage $v_{in}(t)$ is applied to a capacitor C to generate a current

$$i(t) = C \frac{dv_{in}(t)}{dt} \quad (1)$$

Assuming a sinewave excitation $v_{in}(t)$ described by a voltage phasor $V_{in} = A_{in} + jB_{in}$, in the linear response approximation the output $v_{out}(t)$ can be written as $V_{out} = Z(\omega)(j\omega C)V_{in}$, where $Z(\omega) = R(\omega)(1 + j\omega\tau)$ is the complex transimpedance of A at the angular frequency ω , and τ is its time constant. Because of (1),

$$Z = \frac{1}{j\omega C} \frac{V_{out}}{V_{in}} = \frac{1}{j\omega C} \frac{A_{out} + jB_{out}}{A_{in} + jB_{in}} \quad (2)$$

Under the assumption of a very slow excitation $\omega\tau \ll 1$, we can approximate $Z(\omega) = R(\omega = 0)$, and

$$R = \frac{1}{\omega C} \left| \frac{A_{out} + jB_{out}}{A_{in} + jB_{in}} \right|. \quad (3)$$

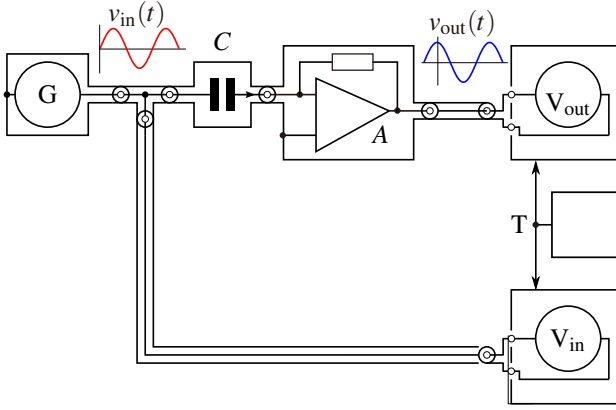

Figure 2. Schematic diagram of the calibration setup. G is the voltage generator, C is the injection capacitor, and A is the transresistance amplifier to be calibrated. V_{in} and V_{out} are the multimeters that sample the voltages $v_{in}(t)$ and $v_{out}(t)$; they are both triggered by the same timebase T .

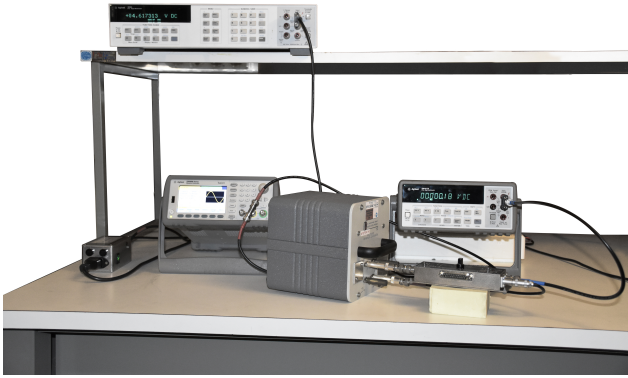

Figure 3. Picture of the calibration setup corresponding to the scheme represented in Fig. 2. V_{in} is on the top left, under it there is the generator G . The capacitor C is in the center while A and V_{out} are on the bottom right.

3 Calibration setup

The schematic diagram of the implementation proposed is displayed in Fig. 2. The generator G outputs the sinewave voltage v_{in} , which is applied to the two-port capacitor C and measured by the sampling voltmeter V_{in} .

The amplifier A under calibration outputs v_{out} , which is sampled by the voltmeter V_{out} . The samples from v_{in} and v_{out} are synchronized by the trigger signal generated by a precision timebase T , but are not synchronous with the period of v_{in} . The samples are acquired and stored using an interface bus IEEE-488.

Fig. 3 shows a picture of the calibration setup. The circuit is coaxial to minimize interferences. C is directly connected to A , without any cable, in order to reduce possible dielectric absorption caused by cables.

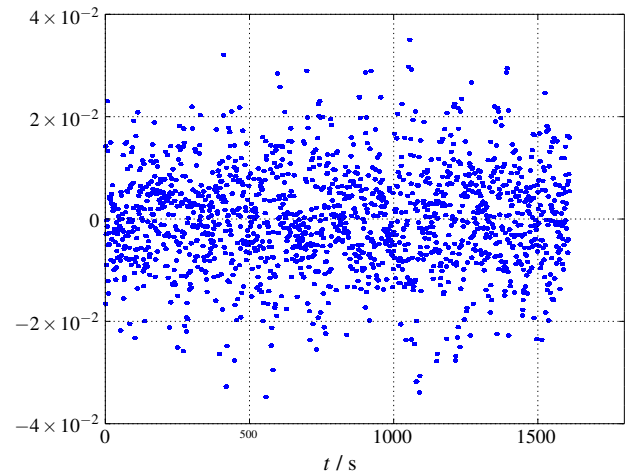
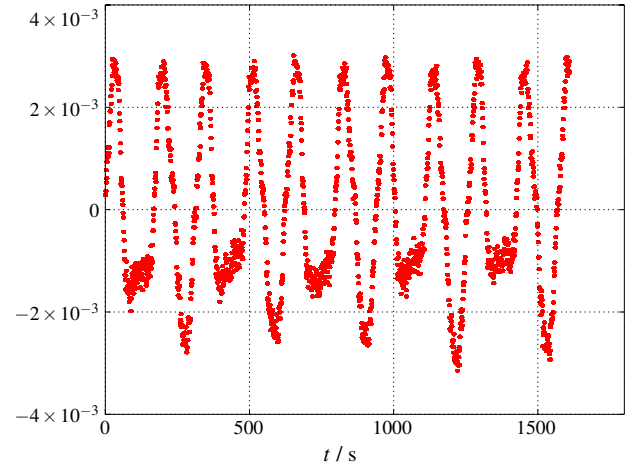
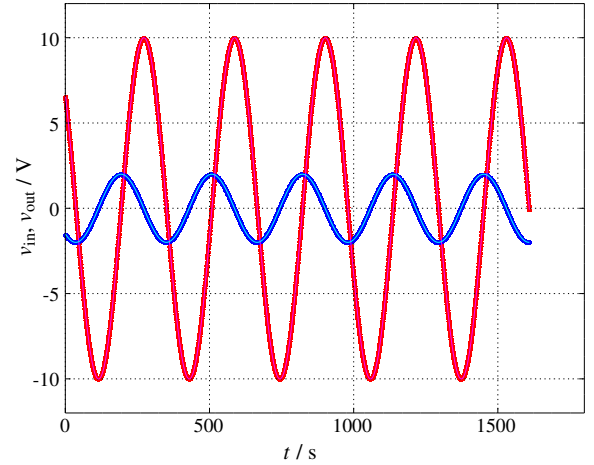

Figure 4. An example of the outcome of a measurement, for the case $R_{nom} = 10 \text{ G}\Omega$ and $C_{nom} = 1 \text{ nF}$. (top) Time series of sampled signals v_{in} (—) and v_{out} (—). (middle) Residuals of the seven-parameter fitting on v_{in} , showing the distortion of G . (bottom) Fit residuals of v_{out} , dominated by the noise of A .

3.1 Instrumentation

The present implementation, under development, employs for G a commercial Agilent mod. 33500B. The capacitors C available are in the range $C_{\text{nom}} = 1 \text{ pF}$ to 1000 pF , with a gas dielectric to avoid dielectric absorption phenomena typical of solid-dielectric capacitors [9]. V_{in} is a multimeter Agilent mod. 3458A, while V_{out} is a multimeter Agilent mod. 34401A. Both instruments are in the dc sampling, external trigger mode; autozero and autorange functions are disabled. The quartz timebase T has a frequency of $\approx 950 \text{ MHz}$.

The results reported in Sec. 4 refer to a transresistance amplifier FEMTO mod. DDP-300, often employed in experiments with single-electron devices [6, 7]. This instrument has a manually-switchable nominal transresistance gain R_{nom} in the range $10 \text{ k}\Omega$ – $10 \text{ T}\Omega$; the specified R_{nom} accuracy is $\pm 1 \%$. The instrument allows input capacitances up to 1 nF . The amplifier has a voltage output span of $\pm 10 \text{ V}$ and three different lowpass output filter configurations: the measurements here reported are obtained with a cut-off frequency of 400 Hz .

4 Results and discussion

The test results here reported refer to a calibration of the nominal gain $R_{\text{nom}} = 10 \text{ G}\Omega$ of A . The sinewave input voltage $v_{\text{in}}(t)$ had a peak-to-peak amplitude of 10 V and a frequency of $\approx 3 \text{ MHz}$. An acquisition lasts about 5 waveform periods, corresponding to a duration of 15 min .

The v_{in} and v_{out} sinewaves are identified by sine-fitting. The algorithm employed [10] allows to estimate the seven parameters of two sampled sinewave signals with arbitrary amplitude and phase and possible dc offset, with the same frequency:

$$\begin{aligned} v_{\text{in}}(t) &= A_{\text{in}} \cos(\omega t) + B_{\text{in}} \sin(\omega t) + C_{\text{in}}, \\ v_{\text{out}}(t) &= A_{\text{out}} \cos(\omega t) + B_{\text{out}} \sin(\omega t) + C_{\text{out}}, \end{aligned} \quad (4)$$

The parameters identified by the fitting allow to calculate R with Eq. (3).

An example of data acquisition and processing is reported in Fig. 4.

5 Conclusions

The use of a low-frequency sinewave signal in the implementation of the capacitance-charging method allows to employ commercial instrumentation in the setup, which can thus be easily replicated. The measurements are performed in the same way of setups based on a trapezoidal-wave source, but require a different data treatment, here based on sine-fitting techniques.

The setup is presently being optimized to reduce distortion effects (that can be appreciated in Fig. 4), by performing

calibration experiments on different current values and amplifier ranges. A preliminary analysis shows that, for the particular amplifier model being calibrated, the effects of the amplifier nonzero input impedance and limited bandwidth can be considered negligible for the measurement frequency here employed. A more complete analysis of these effects will be reported at the Conference.

References

- [1] G.-D. Willenberg, H. N. Tauscher, and P. Warnecke, "A traceable precision current source for currents between 100 nA and 10 pA ," *IEEE Trans. Instr. Meas.*, vol. 52, no. 2, pp. 436–439, Apr. 2003.
- [2] G.-D. Willenberg and H. N. Tauscher, "Novel digital voltage ramp generator for use in precision current sources in the picoampere range," *IEEE Trans. Instr. Meas.*, vol. 58, no. 4, pp. 756–760, Apr. 2009.
- [3] H. van den Brom, P. de la Court, and G. Rietveld, "Accurate subpicoampere current source based on a differentiating capacitor with software-controlled non-linearity compensation," *IEEE Trans. Instr. Meas.*, vol. 54, no. 2, pp. 554–558, Apr. 2005.
- [4] L. Callegaro, V. D'Elia, and B. Trinchera, "A current source for picoammeter calibration," *IEEE Trans. Instr. Meas.*, vol. 56, no. 4, pp. 1198–1201, Aug. 2007.
- [5] I. Finardi and L. Callegaro, "Calibration setup for ultralow-current transresistance amplifiers," vol. 2017 IEEE International Instrumentation and Measurement Technology Conference, Torino, Italy, May 22, 25 2017, in press. See also arXiv:1610.05148.
- [6] J. Lehtinen, "Quantum fluctuations in superconducting nanostructures," Ph.D. dissertation, ISBN: 978-951-39-5688-9. [Online]. Available: <http://www.jyu.fi/static/fysiikka/vaitoskirjat/2014/Lehtinen-Janne-2014.pdf>
- [7] A. Rossi, T. Tanttu, K. Y. Tan, I. Iisakka, R. Zhao, K. W. Chan, G. C. Tettamanzi, S. Rogge, A. S. Dzurak, and M. Möttönen, "An accurate single-electron pump based on a highly tunable silicon quantum dot," *Nano lett.*, vol. 14, no. 6, pp. 3405–3411, 2014.
- [8] E. Mykkänen, J. Lehtinen, A. Kemppinen, C. Krause, D. Drung, J. Nissilä, and A. Manninen, "Reducing current noise in cryogenic experiments by vacuum-insulated cables," *arXiv:1604.03903*, 2016.
- [9] R. A. Pease, "Understand capacitor soakage to optimize analog systems," *Electronic Design*, pp. 125–129, 1982.
- [10] P. M. Ramos and A. C. Serra, "A new sine-fitting algorithm for accurate amplitude and phase measurements in two channel acquisition systems," *Measurement*, vol. 41, no. 2, pp. 135–143, 2008.