

Forming Simulations of Niobium Sheets - Upgrade of the Numerical Model and Outcome for Novel Productions

Original

Forming Simulations of Niobium Sheets - Upgrade of the Numerical Model and Outcome for Novel Productions / Amorim Carvalho, A., Brachet, J., Bulat, B., Capatina, O., Dallochio, A., Garlaschè, M., Narduzzi, M., Peroni, L., Prever Loiri, L., Scapin, M.. - ELETTRONICO. - (2017), pp. 1-8. (European LS-DYNA Conference Salisburgo (Austria) 9-11 Maggio 2017).

Availability:

This version is available at: 11583/2677126 since: 2017-07-24T11:07:09Z

Publisher:

-

Published

DOI:

Terms of use:

This article is made available under terms and conditions as specified in the corresponding bibliographic description in the repository

Publisher copyright

(Article begins on next page)

Forming Simulations of Niobium Sheets: Evolution of the Numerical Model

A. Amorim Carvalho¹, J. Brachet¹, B. Bulat¹, O. Capatina¹, A. Dallochio¹,
M. Garlaschè¹, M. Narduzzi¹, L. Peroni², L. Prever-Loiri¹, M. Scapin²

¹CERN, ²Politecnico di Torino

1 Introduction

One of the work-packages in the framework of the Large Hadron Collider (LHC) High-Luminosity (HL-LHC) upgrade involves the fabrication, installation and commissioning of Crab Cavities in the particle accelerator [1]. Crab Cavities are special Radio Frequency (RF) cavities that produce rotation of the protons beam leading to a larger number of collisions by augmenting the area of intersection between two crossing beams [2].

Two alternative concepts of such systems were proposed: the Double Quarter Wave (DQW), shown in Fig. 1, and the Radio Frequency Dipole (RFD), shown in Fig. 2. Two units of the DQW Crab Cavity were successfully produced between early 2016 and the beginning of 2017; while two units of the RFD Crab Cavity will be produced in the second quarter of 2017.

To fabricate these cavities, the different sub-components are shaped from 4 mm thick niobium sheets, machined and then Electron Beam Welded (EBW) into one final assembly. Sheet metal forming is the preferred fabrication method as it minimizes the amount of Niobium required, whose high market price constitutes a considerable factor of the total cost of the Crab Cavity. To obtain its final exotic shape while keeping manufacturing feasibility, the DQW crab cavity was divided into 3 major components: Bowl, Main Body and Elliptical Cap (see Fig. 1.b).

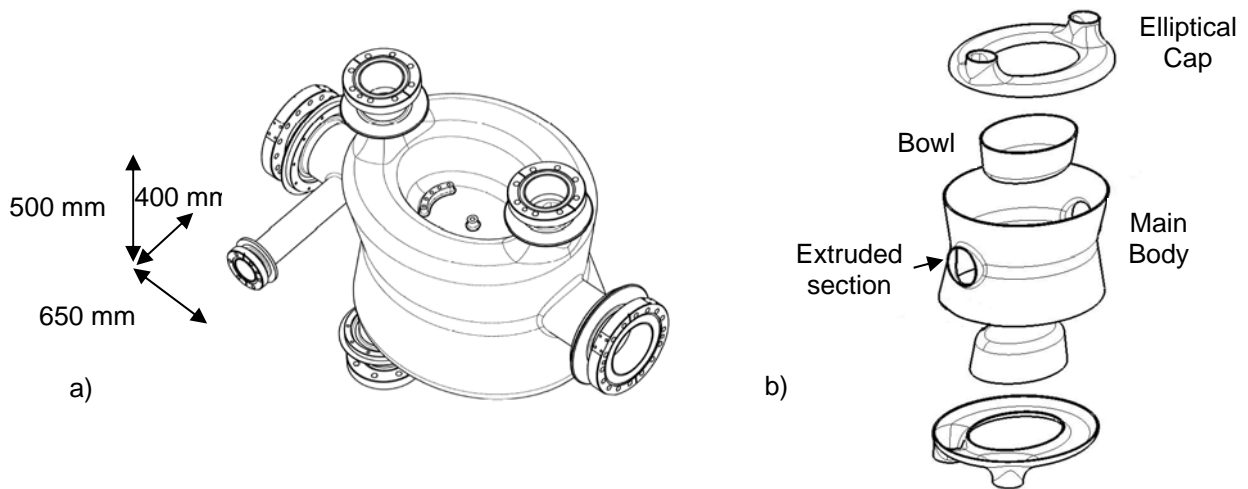

Fig. 1: (a) Double Quarter Wave (DQW) and
(b) its components: Elliptical Cap, Bowl and Main Body.

The ability of the cavity to rotate the protons beam with the right frequency is highly dependent on the shape of the cavity. This dependency directly translates into tight geometrical tolerances, ranging from 0.6 mm for most of the shape down to 0.3 mm in the most critical areas for RF.

Given the large deformation and displacements embedded in the shaping processes, an explicit approach via LS-DYNA[®] was chosen for simulation.

The simulation campaign has been performed in parallel with the shaping of the DQW Crab Cavity. The simulation results allowed a faster iteration on the design of the fabrication tools and a better understanding of the physical phenomena involved in the processes, thus ultimately helping to steer manufacturing choices. The results also allowed an estimation of the expected shape outcome and the thickness distribution of the Niobium components. A thorough presentation of the simulations performed for these forming processes, the evaluation of fabricated components, the model benchmarking procedures and results were made in the LS-DYNA Forum in 2016 [3].

To allow further guidance and accuracy for the production of the second Crab Cavity type, the RFD (Fig. 2), an upgraded numerical model is currently under development.

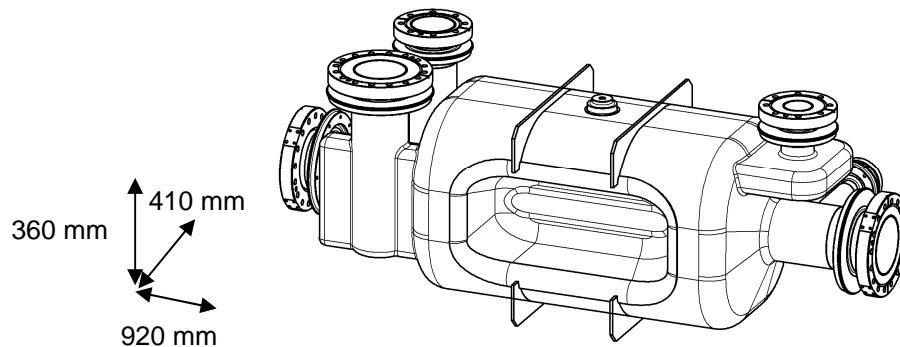

Fig. 2: Radio Frequency Dipole (RFD).

This paper presents the latest results from the simulations of the DQW Crab Cavity and the ongoing work for the upgrade of the numerical model, focusing on the material model and on the element formulation, which will be used to simulate the forming processes of the RFD Crab Cavity. The paper details the procedures followed to perform such upgrade and the main challenges faced. In chapter 2, the motivation that led to the study is presented in a conceptual approach and further comments regarding the previous experience with the current model are mentioned. In chapter 3, the procedure followed is presented together with the main challenges faced.

2 Niobium Sheets Properties and its Modeling

Given the small series production and the high material cost, simulation plays an important role in the production of Crab Cavities. To minimize costs and time spent in initial manufacturing tests, the objective is to simulate the forming processes with a precision equivalent to the tightest fabrication tolerances (0.3 mm). Furthermore, diverse physical phenomena occurring during the processes are of key importance for the detailed design of the fabrication tools, for example: the appearance of wrinkles, the effects of coining processes and springback effects.

2.1 Conceptual Approach

When considering the sheet metal forming processes foreseen for the cavity production, many phenomena need to be modeled, such as bending, stretching and compression of the niobium sheets, cyclic behavior of the stress field and complex frictional contacts. Choosing an appropriate element formulation for these effects - together with a validated material model formulation - is the core of this study.

2.1.1 Material Model

The chosen material model must be able to correctly represent the behavior of niobium sheets under the sheet metal forming processes, including the abovementioned effects. Three main material properties have been considered as pertinent for a successful modeling:

- Anisotropy: is one of the main parameters of interest in sheet metal forming processes due to the developed preferred orientations of grains during the severe plastic deformation of the sheet rolling process. Pure niobium sheets have shown to be anisotropic in the through thickness direction in relation to the sheet surface plane [4,5];
- Strain rate: is of interest due to niobium's crystallographic structure – Body Centered Cubic (BCC) [6]. Metals with this crystallographic structure exhibit yield stress and plastic stress curve highly dependent on strain rate. Even though the forming processes foreseen do not carry a large variation in tool speed, strain rate still varies on non-negligible amounts on a local level. For the relevant processes, a maximum strain rate value of 10^{-1} s^{-1} is expected;
- Cyclic plasticity: is a relevant parameter for the processes under study. Deep drawing of the Bowl (component of the DQW Crab Cavity), for example, forces regions of the niobium sheet to undergo compression-tension cycles, such stresses being released during the following phase of springback. Figure 3 shows the complex tension – compression behavior in the process: a) compression in the lower surface of the sheet and tension in the upper surface during bending of the

sheet; b) compression in the azimuthal direction as the sheet travels inside the mould; c) tension due to high stretching occurring in the sheet while the punch travels downwards. After the forming process, follows the release of the tensions during springback.

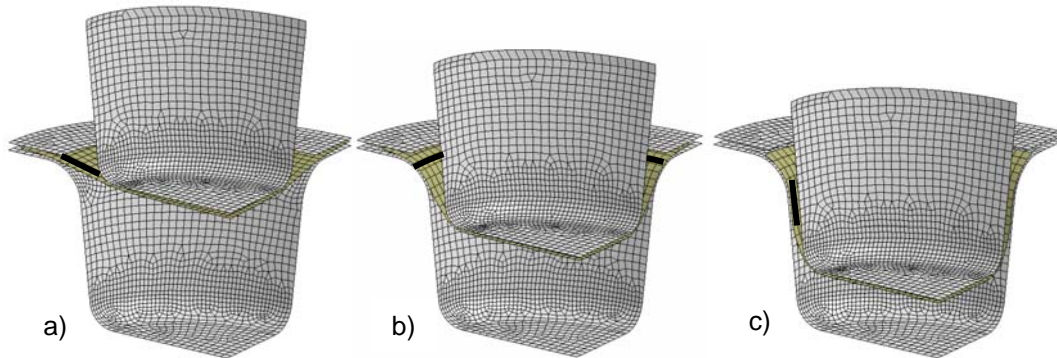

Fig. 3: Deep drawing process of the component Bowl where there is a complex tension-compression behavior which can be followed by the darker lines: a) tension (upper surface) and compression (lower surface) b) compression c) tension

2.1.2 Numerical Model

The choice of element formulation stems from a compromise among the different advantages and disadvantages which each formulation possesses with respect to the scope of the simulation. Three alternatives are being considered for the ongoing modelling campaign:

- i) Shell elements present themselves as a good compromise between computational cost and accuracy. They are computationally efficient due to the associated low number of nodes. Furthermore, it is generally easier to obtain a good mesh with shell elements than with solid elements and the post processing is faster when considering larger models. LS-DYNA provides a combination of options optimized for the use of shell elements in sheet metal forming processes which give them a considerable advantage. Shell elements perform best in a bending only stress condition; even so, they have a plane stress formulation and under compression between two surfaces, the contact forces will act on the same nodes (therefore on the same surface).
- ii) Solids elements have a three dimensional stress state formulation. This means that under a multidimensional compression process such as coining, load would act on the two different surfaces (instead of one, as happens in shells). In fact, solids generally have more realistic boundary conditions as they possess faces instead of edges. Solids are, nevertheless, computationally more expensive than shells. Additionally, under bending, solids are prone to element locking and a discretization with several layers of elements is recommended in the through thickness direction, aggravating the cost of the calculation.
- iii) Thick shells are a mix between solids and shells. They are solid elements with a shell oriented formulation and can be a good compromise for the forming processes as they merge the computational slenderness of shells with the ability of multidirectional stress state solution of solids.

2.2 Modelling Experience from DQW manufacturing

The DQW Crab Cavity has been produced and it provides a useful validation of the numerical approach followed as well as a lesson learned.

Modelling for DQW manufacturing processes has been performed following standard recommendations for sheet metal forming simulations in LS-DYNA [7, 8, 9]: shell element formulation ELFORM 16 was used with seven integration points through thickness (NIP) and element size ranging between 1 mm and 4 mm – depending on the aim of the given simulation.

Other important parameters used were shell thickness update with membrane straining (ISTUPD=1); thickness strain formulation governed by the contact stress (IDOF=3); and the full projection warping stiffness (IHQ=8) for the niobium sheet [3]

To avoid unrealistic effects such as inertia or shock waves while still keeping the computational cost low, the tool velocity was kept below 2 mm/ms and a maximum added mass of 2% was allowed.

All the punches, pads and molds were modeled as rigid bodies with material model *MAT_RIGID and element formulation ELFORM 2.

The material model `*MAT_PIECEWISE_LINEAR_PLASTICITY` was used which allowed modeling of the plastic regime. A stress strain curve, obtained from tests performed at CERN, was introduced in the model.

The results obtained are well aligned with the objectives set for the simulations: errors of 0.1 mm on the thickness estimation and 0.3 mm on the geometrical estimations [3].

As an example of these results is the outcome obtained from the fabrication of the Bowl by a deep drawing process. Figure 5 shows $R_{METR}(\alpha)$ and $R_{SIM}(\alpha)$, which are the error of results obtained from metrology and simulation, respectively, with regard to the theoretical shape of the Bowl $R_{THEO}(\alpha)$ where the radius $R(\alpha)$ is calculated at the trimming height of the external Bowl surface in relation to the Bowl center (see Fig. 4). This comparison shows that maximum error between simulation and reality is 0.3 mm and the average error 0.15 mm.

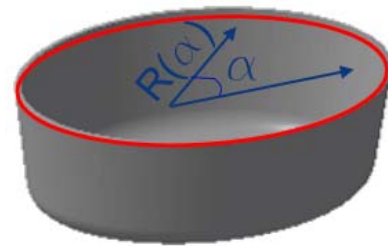

Fig.4: Trimming line in the Bowl.

The oscillations observed in the $R_{SIM}(\alpha)$ curve, defined in figure 5, are the result of incipient wrinkles which appear on the top of the Bowl. These wrinkles can also be observed with lower intensity in the $R_{METR}(\alpha)$ curve. While the current model thus allows a qualitative prediction of the appearance of wrinkles, a quantitative prediction is beyond its capabilities.

In regard to the thickness distribution, it was observed that the maximum error was 0.08 mm while the average errors were 0.025 mm for the minor axis and 0.03 mm for the major axis. Taking into account the percentile error in relation to the local measured thickness, the maximum error amounts to 2.2%.

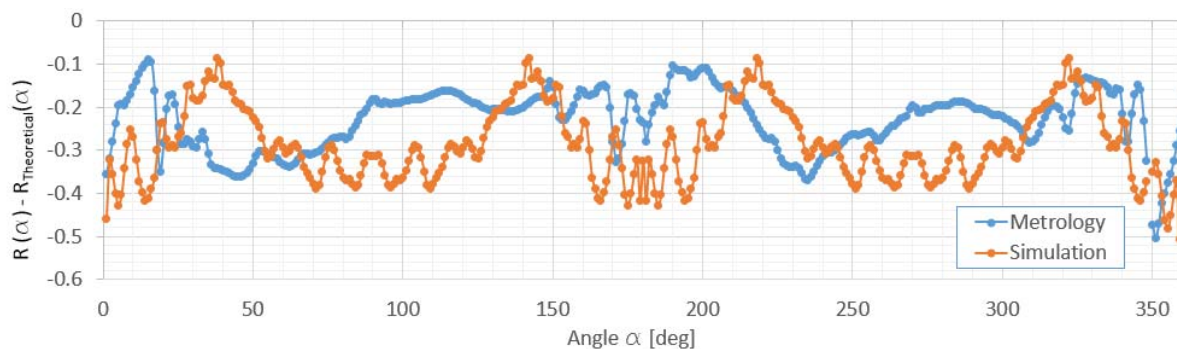

Fig. 5: Comparison of both the real error and the simulation error in relation to the theoretical line.

Although it is legitimate to conclude that simulations of the fabrication processes did steer the manufacturing choices and accelerated the iterative process of the tooling design, it is possible to identify aspects that can be improved. The modelling of the following phenomena requires particular attention:

- Coining is an important step in the forming processes at CERN as it forces local material to flow between the molds and the punches, thus inducing a further shaping of non-conformal areas. It is usually performed after every forming process using the same tools and usually applying a higher load;
- Wrinkles are a typical nuisance of deep drawing processes, occurring due to local collapsing in areas of fiber compression. The intensity of the wrinkles can be controlled, to a certain extent, by the use of pressure pads;
- Occurrence of springback is a crucial part of the forming processes. Such phenomenon occurs both after shaping as after trimming – the subcomponents are machined to fit shape tolerances, this step entails springback due to the removal of material. Measurement of such phenomenon was not possible at CERN. On the contrary, displacements after coining and consequent springback were measured and compared with simulations.

In addition to the above-mentioned effects, few process parameters entail variability which cannot be easily accounted for in the simulations:

- Thickness of the procured niobium sheets ranges in the ± 0.1 mm interval, where such variation is not systematic along the sheets, due to the many uncontrollable variables in the production process.

- Friction coefficient values: implementation of lubricants prior to shaping is a manual process thus entailing high variability on the final friction coefficients. Friction values introduced have thus been based on the author's experience.

3 On-going Work: Procedures Followed for the Upgrade of the Numerical Model

As mentioned in chapter 2.2, the numerical and material models initially adopted have been based on available literature and experimental data obtained from standard tensile tests performed at CERN which allowed the immediate launch of simulations of the forming processes of the DQW Crab Cavity. In parallel to the fabrication of the DQW cavity, two actions have been launched to fully characterize the mechanical behavior of niobium sheets and improve the precision of the results by upgrading the model:

- A material characterization campaign to cover the material properties: anisotropy, strain rate and cyclic plasticity;
- A numerical formulation optimization campaign to develop a model that contemplates more accurate material models and elements formulations, so to include all phenomena of interest (see chapter 2.2).

If, on the one hand, these updates may result in a higher computational cost; on the other hand, they are expected to bring valuable insights into the details of the formed components.

3.1 Material Characterization Campaign

To obtain the required properties of anisotropy, strain rate and cyclic plasticity (section 2.1), the following tests were performed:

- Monotonic tensile tests for anisotropy in the directions: 0°, 45° and 90°;
- Monotonic tensile tests for strain rate at the strain rates: 10^{-3} s^{-1} , 10^{-2} s^{-1} and 10^{-1} s^{-1} ;
- Cyclic tests for cyclic plasticity: tension – compression – tension and compression – tension;

The specimen used for these tests is represented in figure 6. This shape was chosen for its adaptability to the testing equipment, for its small size (thus reducing overall material expenditure) while minimizing inclination to buckling.

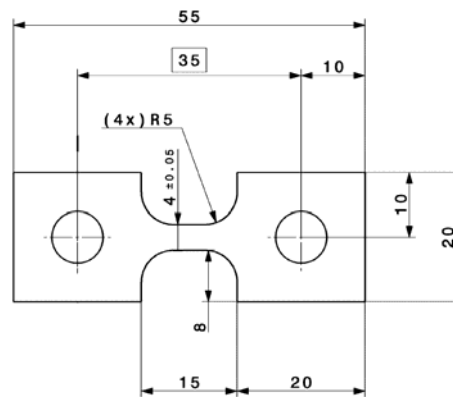

- Fig. 6: Specimen used for the tests. Thickness is 4mm. Units in mm.

The tests were recorded with cameras and, using the inverse method [10], the simulated Load vs. Displacement curve has been compared with experimental data. Using LS-OPT, the variables that define the material model were optimized to ensure a fit of the curve. Figure 7 illustrates how the evaluation between simulation and the recorded tests has been performed and the procedure for iterating the model.

The three different properties (anisotropy, strain rate and cyclic plasticity) are, in a first stage, considered independently. This approach allows the authors to understand what the driving property of the material is. In a second stage, it might be advantageous to combine two or three different properties, depending on their impact in the formability of the material.

Depending on the results observed: the impact that each property has in the overall performance of the material, different material models have been chosen to best suit each possibility. In table 1, the material models being considered are listed according to the relevant property.

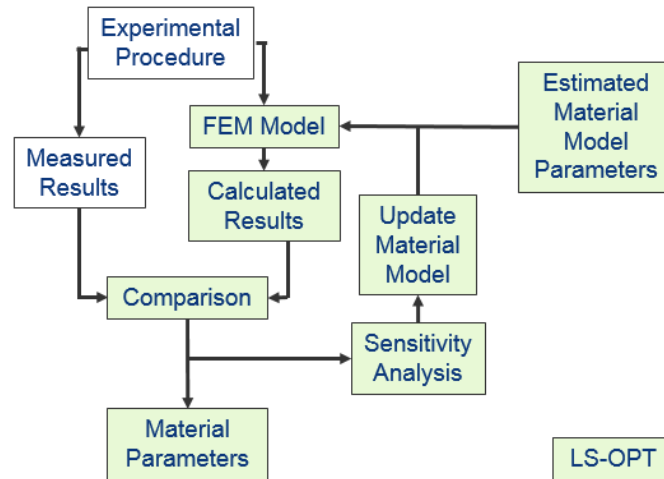

Fig. 7: Schematic of the procedure followed for the parameter identification [11].

Anisotropy	*MAT_036
Strain Rate	*MAT_036
Cyclic Plasticity	*MAT_125
Anisotropy & Strain Rate	*MAT_036
Anisotropy & Cyclic Plasticity	*MAT_226

Table 1: Material Models chosen according to the relevant properties

A set of iterative simulations has been performed to ensure that the identified parameters and the material model are appropriate for the forming processes under study. This is so because different combinations of the material model parameters may be produced from the optimization study and still fit the same tested curve. Another important aspect of this iteration is that these steps allow a gradual increase in complexity enabling a better understanding of the behavior of the model.

As illustrated in figure 8: in a first stage, standard simulation cases such as a cantilever test and a 3 point bend test which have known analytical solutions are performed. In a second stage, more complex simulations which are representative of the forming processes are tested – the processes performed for the fabrication of the DQW Crab Cavity are used which allow a thorough comparison with reality.

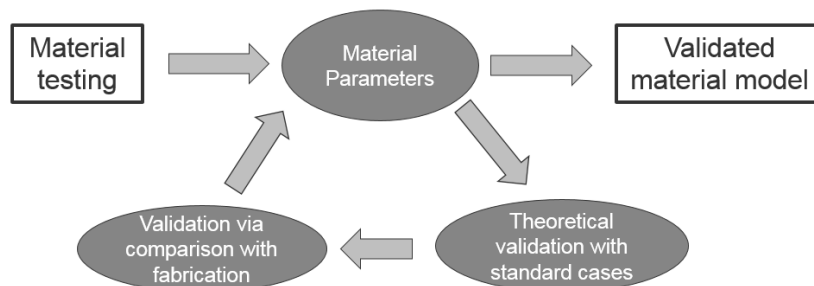

Fig. 8 Procedure adopted for validating the material models.

3.2 Numerical formulation

While shell elements are a convenient compromise for a fast design iteration, their limitations to grasp more demanding physical phenomena led the authors to look further into solid element formulations.

In this study, the authors are trying to guarantee the correct modeling of the processes and its final shape with particular emphasis in coining and the estimation of wrinkles.

To fit the element formulations, ELFORM-1 has demonstrated a good fit for SOLIDs and ELFORM 5 for TSHELLS. With the choice of element formulation, one must then consider appropriate contact definitions, controls and boundary conditions.

To find an appropriate combination of all these parameters, another iteration, based on available publications together with the world-known trial and error method, has been launched. In a similar fashion to what is done for the material model, this iteration is structured with increasing complexity to

guarantee that the difficulties arising are easy to master. In this iteration, several sensitivity analysis are being launched to understand the impact of the element formulations and the other relevant parameters: contact definitions, controls and boundary conditions. Figure 9 illustrates this iterative procedure.

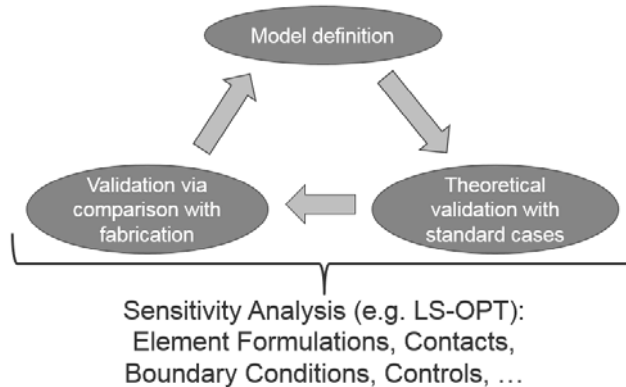

Fig. 9: Procedure followed to achieve an appropriate numerical formulation is similar to procedure to validate the material model alone.

4 Conclusions and Future Outlook

In this article, a description of the procedures followed to obtain a complete numerical model for niobium sheets under forming processes was presented.

A strategy for testing niobium sheets was presented together with a conceptual prediction of the behavior of different element formulations. Moreover, accumulated experience of sheet metal forming simulation processes allowed a more complete overview of the performance of the models.

The procedures pursued for the material models parameters identification were presented together with the chosen models to represent each of the targeted properties: anisotropy, strain rate and cyclic plasticity. The model evaluation procedure was then explained, consisting of different simulations with an increasing level of complexity.

The models are currently being evaluated and are expected to be used for simulating the forming processes necessary to fabricate the RFD Crab Cavity.

One further outcome intended from the material characterization campaign is to define an internal standard procedure to test niobium sheets originating from different batches. This is so due to a variability of about 30% that has been observed for the yield stress value when considering niobium sheets purchased from different suppliers. Performing a batch specific mechanical characterization campaign thus becomes of utmost importance.

5 Acknowledgments

This research is supported by the HL-LHC project.

6 References

- [1] Zaroni C. et al., "The Crab Cavities Cryomodule for SPS test", IPAC17, Copenhagen, Denmark, 2017
- [2] Apollinari, G.; Bejar Alonso, I.; Bruning, O.; Lamont, M.; Rossi, L., "High-Luminosity Large Hadron Collider (HL-LHC): Preliminary Design Report, Geneva: CERN, 2015. – 285 p.
- [3] Amorim Carvalho, A; Brachet, Jean-Pierre; Bulat, Bartosz; Capatina, Ofelia; Dalocchio, Alessandro; Garlaschè, Marco; Narduzzi, Manuele; Prever-Loiri; Laurent, "Simulation of Niobium Sheets Forming for Accelerating Cavities: Challenges and Achievements", LS-DYNA Forum 2016
- [4] Zamiri, A.; Pourgophrat, F.: "Characterization and development of an evolutionary yield function for the superconducting niobium sheet", International Journal of Solids and Structures 44 (2007) 8627-8647
- [5] Jiang, H.; Baars, H.; Zamiri, A.; Bieler, T. R. ; Bauer, P.; Compton, C.; Grimm, T.L.; Mechanical Properties of high RRR Niobium with Different Texture
- [6] Gray III, G.T.: High-strain rate deformation: mechanical behavior and deformation substructures induced, Annual Review of Materials Research, 2012, 42:285-303

- [7] Maker, Bradley N. and Zhu, Xinhai: "Input Parameters for Metal Forming Simulation using LS-DYNA", April, 2000
- [8] Maker, Bradley N. and Zhu, Xinhai: "Input Parameters for Springback Simulation using LS-DYNA", June, 2001
- [9] Maker, Bradley N. and Zhu, Xinhai: "A Procedure for Springback Analysis Using LS-DYNA, October", 2003
- [10] Scapin M., Peroni L., Peroni M., 'Parameters identification in strain-rate and thermal sensitive visco-plastic material model for an alumina dispersion strengthened copper', Int. J. of Impact Eng., vol. 40-41 (2012) 58-57
- [11] Fichera C., "High Strain-Rate and Temperature Behaviour of Metals: Advanced Testing and Modeling", PhD Thesis at Politecnico Di Torino, 2015