

Multi-physics analysis of a 1MW gyrotron cavity cooled by mini-channels

Original

Multi-physics analysis of a 1MW gyrotron cavity cooled by mini-channels / Bertinetti, Andrea; Avramidis, K. A.; Albajar, F.; Cau, F.; Cismondi, F.; Rozier, Y.; Savoldi, Laura; Zanino, Roberto. - In: FUSION ENGINEERING AND DESIGN. - ISSN 0920-3796. - STAMPA. - 123:(2017), pp. 313-316. [10.1016/j.fusengdes.2017.05.016]

Availability:

This version is available at: 11583/2676435 since: 2018-06-28T12:01:44Z

Publisher:

Elsevier Ltd

Published

DOI:10.1016/j.fusengdes.2017.05.016

Terms of use:

This article is made available under terms and conditions as specified in the corresponding bibliographic description in the repository

Publisher copyright

Elsevier postprint/Author's Accepted Manuscript

© 2017. This manuscript version is made available under the CC-BY-NC-ND 4.0 license
<http://creativecommons.org/licenses/by-nc-nd/4.0/>. The final authenticated version is available online at:
<http://dx.doi.org/10.1016/j.fusengdes.2017.05.016>

(Article begins on next page)

Multi-physics analysis of a 1 MW gyrotron cavity cooled by mini-channels

A. Bertinetti^a, K. A. Avramidis^b, F. Albajar^c, F. Cau^c, F. Cismondi^d, Y. Rozier^e, L. Savoldi^a, R. Zanino^a

^a NEMO group, Dipartimento Energia, Politecnico di Torino, corso Duca degli Abruzzi 24, 10129 Torino, Italy

^b IHM, Karlsruhe Institute of Technology, Kaiserstraße 12, 76131 Karlsruhe, Germany

^c Fusion for Energy, c/ Josep Pla 2, 08019 Barcelona, Spain

^d EUROfusion, Boltzmannstraße 2, 85748 Garching, Germany

^e Thales Electron Devices, Rue Marcel Dassault 2, 78140 Vélizy-Villacoublay, France

The interaction cavity of the European 170 GHz, 1 MW Continuous Wave (CW) gyrotron for ITER, which could also be water-cooled using mini-channels as recently proposed, experiences during operation a very large heat load ($>15 \text{ MW/m}^2$) localized on a very short ($< 1 \text{ cm}$) axial length. Such heat loads are typical for high power gyrotrons. As the thermal deformation of the cavity influences the electromagnetic field structure and consequently the gyrotron operation, the analysis of the cavity performance requires the simultaneous solution of the coupled thermal-hydraulic, thermo-mechanic and electro-magnetic fields. In this paper, the thermal behaviour of the cavity under nominal heat load is computed first by CFD. Then a 3D thermo-mechanical model of the cavity is developed, based on the temperature maps computed by CFD, to evaluate the resulting deformation of the inner cavity surface. Finally the deformation is used to compute the updated heat load coming from the electromagnetic field generated by the electron beam in the deformed cavity, which becomes the input for a new iteration of the thermal-hydraulic, thermal-mechanical and electromagnetic analyses. It is shown that this iterative procedure converges to a self-consistent heat-load/temperature-field/deformation-field picture in nominal operating conditions, without exceeding a temperature of $\sim 230 \text{ }^\circ\text{C}$ on the inner surface of the cavity.

Keywords: Nuclear fusion, Electron cyclotron heating, Gyrotron, Resonance cavity, CFD

1. Introduction

In the frame of the development of the European 170 GHz, 1 MW, CW gyrotron for ITER [1], the most critical sub-assemblies, such as the interaction cavity, are being fully qualified. During operation, the interaction cavity of a high power (1 MW) gyrotron experiences a very large heat load ($> 15 \text{ MW/m}^2$), localized on a very short ($< 1 \text{ cm}$) axial length, where any thermal deformation should be carefully assessed to guarantee the gyrotron performance required for ITER [2]. Among the different strategies which can be considered for the cavity cooling [3], we focus here on the use of mini-channels (MC) [4] drilled for the water flow in the annular region around the cavity, as shown in figure 1.

In this paper we consider equally spaced mini-channels drilled in the Glidcop sleeve all around the gyrotron cavity made of Glidcop also (see figure 1b). The manufacturing constraints allow a maximum number of 64 channels in the annular region, semi-circular in shape with a diameter $\phi = 1.5 \text{ mm}$, 0.67 mm apart and 2 mm detached from the cavity heated surface.

2. Analysis approach

The approach adopted in the present paper is based on a coupled 3D multi-field analysis as summarized in figure 2:

- the electro-magnetic (EM) analysis, based on the actual (deformed) profile of the cavity, returns the

heat load on the cavity inner surface, to be used in input for the thermal-hydraulic (TH) analysis

- the TH analysis returns the thermal field of the cavity, to be used in input for the thermo-mechanical (TM) analysis

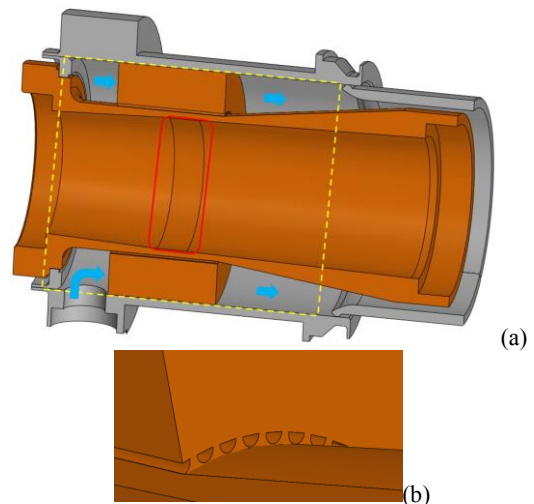

Fig. 1. CAD model of the gyrotron cavity equipped with mini-channels (a) and zoom in the region of the mini-channels block (b): the location of the heat flux peak is highlighted by the red box, the flow direction is specified by the blue arrows and the portion of the cavity used in the simulation is highlighted by the yellow box.

- the TM analysis returns the cavity deformation, to be used in input for the EM analysis.

While the heat load reacts instantaneously to the deformation, and the deformation adapts instantaneously to the variation of the thermal field, the temperature field takes a few seconds to reach a complete stabilization in the cavity. However, since this longest timescale is much shorter than the operating time of the gyrotron in Continuous Wave (CW) operation, the analysis could be performed in a sort of steady-state fashion, starting from an initial heat load, obtained with the undeformed cavity, and iterating on the steady-state solution of the coupled problem, without the need of performing a time-dependent analysis.

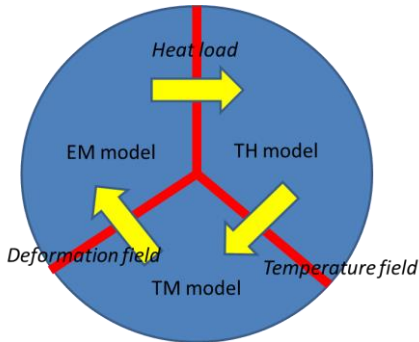

Fig. 2. Multi-physics approach and coupling between the different models.

The geometry used in the simulation is a simplification of the real cavity structure shown in figure 1: the external stainless steel envelop is removed, as well as the outlet part of the structure in order to remove a physical domain and to reduce the computational cost. The total length considered is ~ 80 mm.

3. EM model

For a given cavity inner profile, the high frequency (RF) electromagnetic wave in the cavity, generated from the electron beam, was calculated by the code-package EURIDICE [5], which simulates the beam-wave interaction. The heat load on the cavity wall is the average ohmic loading ρ (i. e. the ohmically dissipated power per surface unit), which was obtained using the well-known formula [6]:

$$\rho = \frac{1}{2\sigma\delta} |\mathbf{H}_t|^2 \quad (1)$$

Here, H_t is the tangential component of the RF magnetic field, σ is the electrical conductivity of the wall, and δ is the skin depth. The influence of both the roughness of the wall surface and of the temperature profile on the effective electrical conductivity were also considered.

4. TH model

For the TH simulations the commercial software STAR-CCM+ v10 [7] is used.

In order to reduce the computational cost, the simulated domain is halved according to the symmetry of the geometry. The coarsest computational mesh giving mesh-independent results is chosen as in [3].

The 3D, steady state, incompressible flow model, with the κ - ω SST turbulence closure [8] and “all y^+ ” wall treatment is adopted. The VOF multiphase flow model is chosen, with the Rohsenow model [9], [10] on in case of boiling onset. Temperature-dependent material properties are used, with the water properties evaluated at 9 bar, and the saturation temperature evaluated at the pressure computed at the heat load peak position (6.9 bar, giving $T_{\text{sat}} = 164$ °C).

An inlet mass flow rate of 22.5 l/min (on the halved domain) at a temperature of 26.85 °C, and an outlet (gauge) pressure of 0 bar are used as boundary conditions, while the solid is considered adiabatic, except for the inner surface where the heat load is applied.

5. TM model

The domain used in the TM simulation is restricted to the solid region (coloured in grey in figure 3) of the TH domain. The TM simulation is performed with STAR-CCM+ v10 [7]: a 3D, steady state, finite-element solid-stress model is adopted, with linear, isotropic and elastic material properties. The thermal stress is computed considering the zero-stress temperature as the inlet temperature of the fluid. The Glidcop density is 8690 kg/m³, its thermal expansion coefficient is 1.85e-5 1/K and Young’s modulus is 120 GPa. The constraints applied to the structure are shown in figure 3: the basement of the cavity is fixed on the gyrotron structure; the top part of the cavity (at the fluid outlet) is free to expand, as well as the external radial surface of the Glidcop where the mini-channels are drilled (this constraint should well represent the real structure).

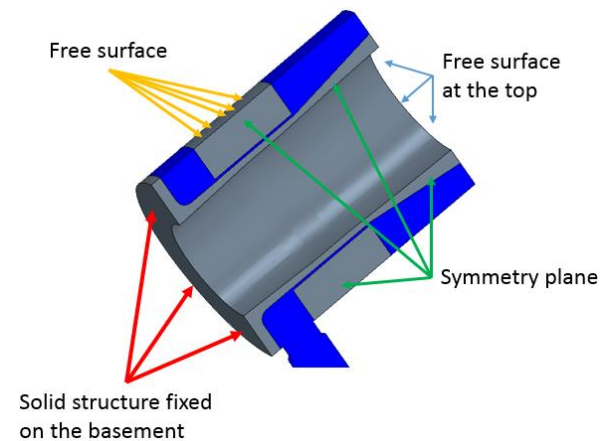

Fig. 3. Mechanical constraints applied on the solid structure in the TM simulations.

6. Results

The initial load on the non-deformed cavity, reported in figure 4, is uniform in the azimuthal direction and is

applied in the TH simulations to compute the steady state pressure field and flow field, which are shown in figure 5a and figure 5b, respectively. The fluid velocity in the central part of the mini-channels length is ~ 13 m/s, with a highly turbulent Re number (~ 15000). In the outlet region of the MC, fluid at high speed will help in the cooling of the wedged structure at the end of the cavity (figure 5b). The coolant pressure drop evaluated between the inlet and the outlet of the cavity is equal to 2.5 bar. The most important contribution on global pressure loss is due to the inlet region of the MC ($\Delta p > 1$ bar), which could be smoothed in future design optimizations.

Stable operating conditions are obtained at the end of the second loop of iterations between the TH-TM-EM simulations, and the results are shown in figures 4 - 8.

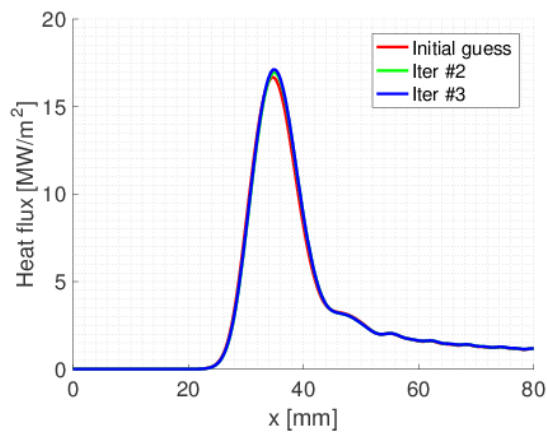

Fig. 4. Axial distribution of the heat loads applied on the cavity inner surface in the different iterations.

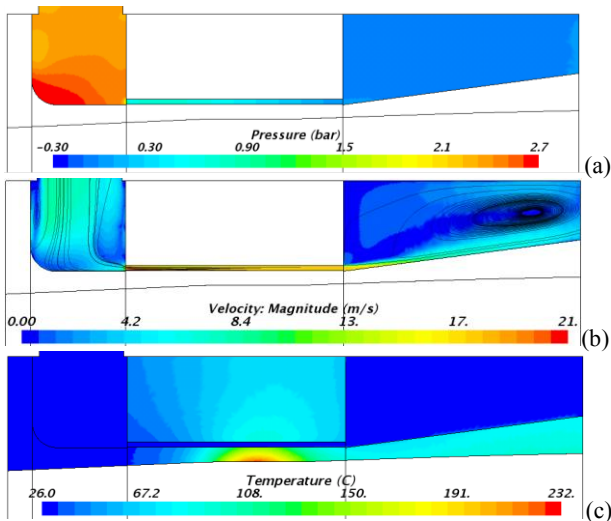

Fig. 5. Computed pressure field (a), velocity field with streamlines (b) and temperature field (c) on the symmetry plane of the cavity.

As far as the fluid temperature is concerned, figure 5c shows the temperature field on an axial (symmetry) plane of the cavity. The maximum coolant temperature (136°C) is lower than the saturation temperature evaluated at the pressure in the central region of the mini-channels (164°C).

Figures 6 and 7 show the temperature field in the solid structure, while in the inset the temperature distribution on the cross section located at the peak of the heat flux shows a maximum radial gradient of $\sim 50^\circ\text{C}/\text{mm}$ in the Glidcop sleeve. The maximum temperature reached by the solid structure is $T_{\text{max}} \sim 232^\circ\text{C}$, under the heat load peak as expected. The effect of the high water velocity in the region at the MC outlet, see figure 5b, cools down the tail of the structure efficiently, with a surface temperature of $\sim 100^\circ\text{C}$, see figure 7. Note that in this region the heat flux is not negligible, see figure 4, because the electromagnetic wave at the right end of the cavity is above cut-off and is traveling towards the quasi-optical output coupler. The maximum value of the heat flux in the last iteration is $17.1\text{ MW}/\text{m}^2$ and it is located in the middle region of the mini-channels block.

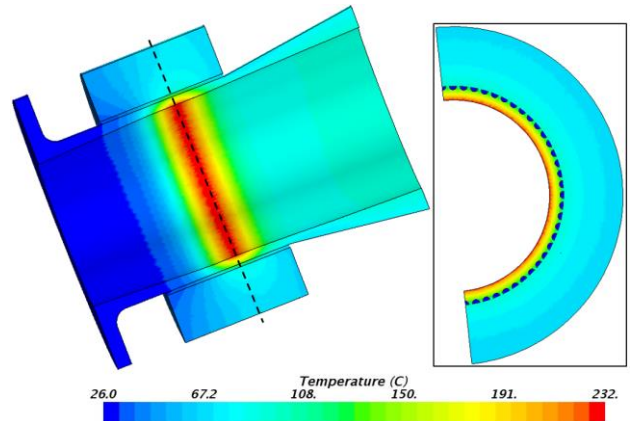

Fig. 6. Temperature field on the solid structure of the gyrotron cavity.

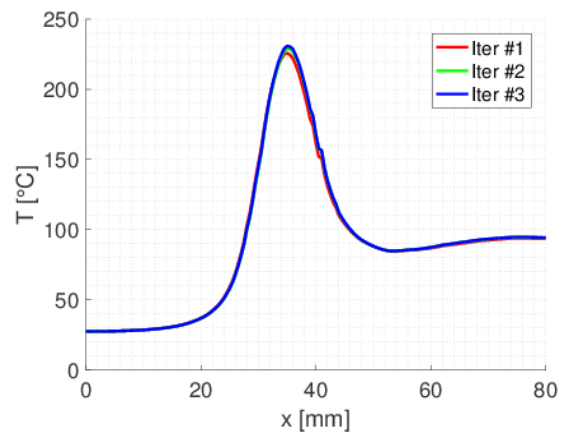

Fig. 7. Poloidal average of the temperature computed on the internal Glidcop surface, as a function of the axial position along the cavity.

Finally, the deformed axial profile of the inner cavity surface, as resulting from the TM simulations at the different iterations, is plotted in figure 8 - the inner surface of the cavity is pushed outward by thermal deformations in view of the free constraint imposed on the radial external surface of the MC block.

Iteration by iteration, the amplitude of the load is almost unchanged with respect to that computed in the cold, un-deformed cavity, leading in turn to a negligible

increase ($\sim 5^\circ\text{C}$) in the temperature peak value (see figure 7).

The nominal gyrotron performance, if the cavity deformation is not taken into account, is ~ 1 MW of microwave power delivered at the window, with an efficiency of $\sim 33\%$ without depressed collector, at the frequency of 170.24 GHz. When the self-consistent cavity deformation is considered, the above performance remains unchanged, which makes the MC cooling fully successful. There is only a frequency down shift to 170.14 GHz, due to the larger radius of the deformed cavity, which remains well within the ITER specification of 170 ± 0.3 GHz.

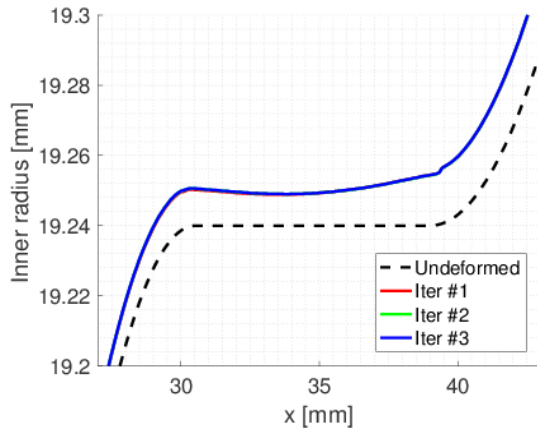

Fig. 8. Zoom of the computed profile of the cavity inner surface in the MC region.

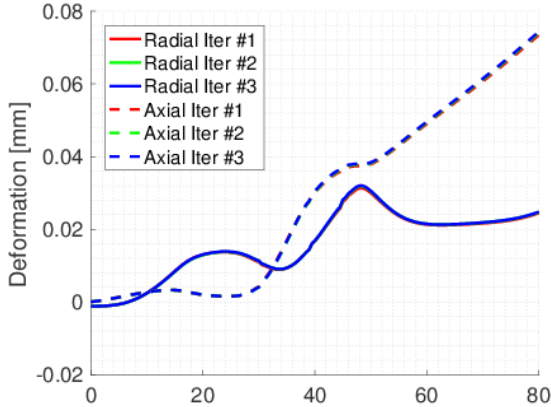

Fig. 9. Axial and radial deformation of the inner cavity surface.

7. Conclusions

A coupled approach based on subsequent iterations of TH, TM and EM analyses of a 170 GHz, 1 MW gyrotron cavity is adopted in this work, in order to evaluate the self-consistent behaviour of the cavity in CW working conditions with mini-channels cooling. The iterative procedure reaches the final cavity working condition after a few iterations.

The computed temperature profile under the operating heat load shows a peak of $\sim 232^\circ\text{C}$ and induces a deformation, which, however, does not impair

the nominal cavity operation. This fully validates the proposed cooling. Additional investigations with different mechanical constraints are underway, in view of further tuning the analysis towards realistic conditions.

Acknowledgements

L. Savoldi acknowledges the financial support by F4E. The work of KAA is partly supported by F4E under Grant F4E-GRT-553 to the European Gyrotron Consortium (EGYC). EGYC is a collaboration among SPC, Switzerland; KIT, Germany; HELLAS, Greece; IFP-CNR, Italy. The views and opinions expressed herein are the sole responsibility of the authors and do not necessarily reflect those of the ITER Organization, F4E, and the European Commission.

References

- [1] F. Albajar et al., Status of Europe's contribution to the ITER EC system, EC-18, Nara, Japan, Apr. 22-25, 2014, EPJ Web of Conferences 87 (2015) 04004.
- [2] C. Darbos et al., Status of the ITER Electron Cyclotron Heating and Current Drive System, Journal of Infrared, Millimeter, and Terahertz Waves 37 (1) (2016) 4-20.
- [3] L. Savoldi, A. Bertinetti, G.F. Nallo, A. Zappatore, R. Zanino, F. Cau, F. Cismondi and Y. Rozier, CFD Analysis of Different Cooling Options for a Gyrotron Cavity, to appear in IEEE Transaction on Plasma Science (2016).
- [4] L. Savoldi, A. Bertinetti, G.F. Nallo, A. Zappatore, R. Zanino, F. Cau, F. Cismondi and Y. Rozier, CFD Analysis of Mini-Channel Cooling for a Gyrotron Cavity, Proceeding of the Symposium on Fusion Engineering 2015, Austin, Texas, May 31 – June 4, 2015.
- [5] K. A. Avramides, I. Gr. Pagonakis, C. T. Iatrou, and J. L. Vomvoridis, EURIDICE: A code-package for gyrotron interaction simulations and cavity design, EC-17, Deurne, The Netherlands, May 7-11, 2012, EPJ Web of Conferences 32 (2012) 04016.
- [6] J. D. Jackson, Classical Electrodynamics, Second Edition, Wiley, 1975, Chapter 8.
- [7] Star-CCM+ User's Manual 10.06.
- [8] F. R. Menter, Review of the shear-stress transport turbulence model experience from an industrial perspective, International Journal of Computational Fluid Dynamics 23 (2009) 305-316.
- [9] W. Rohsenow, A Method of Correlating Heat-Transfer Data for Surface Boiling of Liquids, Transactions of ASME (1951) 969-976.
- [10] D.L. Youchison, M.A. Ulrickson and J.H. Bullock, Prediction of critical heat flux in water-cooled plasma facing components using computational fluid dynamics, Fusion Science Technology 60 (2011) 177-184.