

Natural Gas Trace Compounds Analysis with Innovative Systems: PTR-ToF-MS and FASTGC

Original

Natural Gas Trace Compounds Analysis with Innovative Systems: PTR-ToF-MS and FASTGC / Papurello, Davide; Silvestri, Silvia; Tomasi, Luca; Belcari, Ilaria; Biasioli, Franco; Santarelli, Massimo. - In: ENERGY PROCEDIA. - ISSN 1876-6102. - ELETTRONICO. - 101:(2016), pp. 536-541. (ATI 2016 - 71st Conference of the Italian Thermal Machines Engineering Association) [10.1016/j.egypro.2016.11.068].

Availability:

This version is available at: 11583/2665146 since: 2017-02-14T13:53:30Z

Publisher:

Elsevier

Published

DOI:10.1016/j.egypro.2016.11.068

Terms of use:

This article is made available under terms and conditions as specified in the corresponding bibliographic description in the repository

Publisher copyright

(Article begins on next page)

71st Conference of the Italian Thermal Machines Engineering Association, ATI2016, 14-16
September 2016, Turin, Italy

Natural gas trace compounds analysis with innovative systems: PTR-ToF-MS and FASTGC

Davide Papurello^{a,b*}, Silvia Silvestri^b, Luca Tomasi^b, Ilaria Belcari^b, Franco Biasioli^b,
Massimo Santarelli^a

^aEnergy Department, Politecnico di Torino, C.so Duca degli Abruzzi 24, 10129, Torino - ITALY

^bFondazione Edmund Mach, Via E. MACH 1, San Michele all'adige (TN), 38010 - ITALY

Abstract

The technique of proton transfer reaction mass spectrometry (PTR-MS) couples a proton transfer reagent, usually H₃O⁺, with a drift tube and mass spectrometer to determine concentrations of volatile organic compounds. Proton transfer reaction-mass spectrometry (PTR-MS) has successfully been applied to a wide variety of matrices to identify and to investigate on the behavior of trace compounds; among the possible field of applications we can find: food, air, energy, etc. Natural gas is considered as a fuel for high energy efficiencies applications such as SOFC generators. The ability to distinguish several isobaric aldehydes, ketones, isoprenoids and other compounds is impossible using PTR-MS instrument. In the present research work, PTR-ToF-MS was coupled to a prototype FastGC system allowing for a rapid (90 s) chromatographic separation of the sample headspace prior to PTR-MS analysis. The system was tested on natural gas trace compounds to individuate the major elements and to identify possible issues for the SOFC generators. In comparison to the results obtained by direct injection, FastGC provided additional information, thanks to a less drastic dilution of the sample and due to the chromatographic separation of isomers. This was achieved without increasing duration and complexity of the analysis.

© 2016 The Authors. Published by Elsevier Ltd. This is an open access article under the CC BY-NC-ND license

(<http://creativecommons.org/licenses/by-nc-nd/4.0/>).

Peer-review under responsibility of the Scientific Committee of ATI 2016.

Keywords: PTR-MS, FAST-GC, SOFC, trace compounds, biogas.

* Corresponding author. Tel.: +39-3402351692. E-mail address: davide.papurello@polito.it

Nomenclature

PTR-ToF-MS, Proton Transfer Reaction Time of Flight Mass Spectrometer,
FastGC, Fast Gas Chromatography,
SOFC, Solid Oxide Fuel Cell,

1. Introduction

Nowadays, high efficiency and high reliability of the energy generators systems must be achieved to penetrate the energy market. SOFC systems couple the high and stable efficiency values working even at partial loads, with the good reliability using as a fuel natural gas or biogenous fuels such as biogas [1,2]. One of the main draw back for these systems is the suffering against trace compounds [3]. These compounds are contained both in biogenous and fossil fuels and degrade the SOFC performance reversibly and irreversibly depending on the concentration and family of the compound considered [3]. The ability to distinguish several isobaric aldehydes, ketones, isoprenoids and other compounds is impossible using a classical PTR-MS instrument. To identify and to monitor isobaric compounds, a Time of Flight detector was adopted, while to identify isomers a new prototype developed by Ionicon was considered. The FastGC prototype allowed for a rapid (90 s) chromatographic separation of the sample headspace prior to PTR-MS analysis. The system was tested on natural gas trace compounds to individuate the major elements and to identify possible issues for the SOFC generators. In comparison to the results obtained by direct injection, FastGC provided additional information, thanks to a less drastic dilution of the sample and due to the chromatographic separation of isomers. This was achieved without increasing duration and complexity of the analysis.

2. Experimental and methods

A PTR-ToF-MS instrument was adopted (PTR-ToF 8000, IONICON Analytik, Innsbruck, Austria). This instrument is already able to provides separation and identification of isobaric compounds through its high mass resolution in real-time [4,5]. However, isomers, compounds with the same exact mass, cannot be separated. The built-in FastGC prototype, realized in Ionicon (IONICON Analytik, Innsbruck, Austria) it is now also possible to separate isomeric compounds in fast spectral runs. In short, in a gas chromatographic (GC) column, compounds are primarily separated in retention time according to their boiling point and can be further separated according to their polarity by choosing a polar column [6]. The complete set-up, described in Romano et al., (2014) is reported in figure 1. A short (3.5 m) nonpolar pure dimethyl polysiloxane GC column (MXT-1, 0.25 mm ID, 0.25 mm df, from Restek, Bellefonte, PA), a custom made valve block, a flow controller, and a heating controller, is built into the PTR-ToF-MS and uses the same sample inlet. The column is resistively heated by applying a current, which allows for fast heating rates (>10 °C/s). The low thermal mass of the heating module also ensures fast cooling rates (from 200 °C to 50°C in less than 20 s). The FastGC mode can be activated when required while not affecting the normal PTR-ToF operation otherwise. During all measurements the ionization conditions in the drift tube were the following: 100 °C drift tube temperature, 2.30 mbar drift pressure, 550 V drift voltage. This led to an E/N ratio of 130 Td ($1 \text{ Td} = 10^{17} \text{ cm}^2 \text{ V}^1 \text{ s}^{-1}$). The inlet line consisted of a PEEK capillary tube (internal diameter 0.40 mm) heated at 100 °C. The inlet flow was set at 100 sccm. Analysis took place at an acquisition rate of one spectrum every 900 ms and 90 ms for direct injection and FastGC, respectively. The switch between direct injection and FastGC measurement modes was carried out by means of the custom made valve block electronically controlled (Fig. 1). The natural gas samples were collected in Nalophan bags from the gas network (Snam rete gas - San Michele a/A). Nalophan bags were selected as preferable to Tedlar bags because they gave a cleaner background, as shown by Beghi and Guillot (2008) [7]. It is noted that for some compounds, such as H₂S, Tedlar bags permit better compound recovery as shown by Hansen et al., (2011) [8]. The injection time was set to 2.5 s. The temperature of the FastGC column was left at the temperature inside the instrument of 35 °C, which was optimal for the separation of the investigated highly volatile compounds.

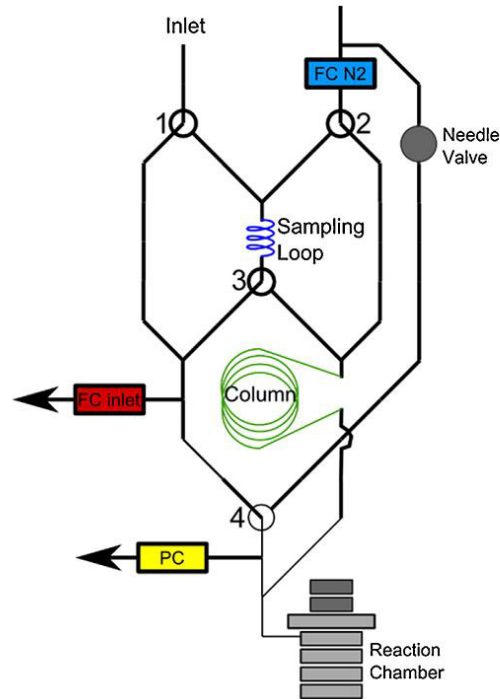

Figure 1 – Schematic drawing of a PTR-ToF-MS inlet system with a FastGC setup, including the additional components valves 1–4, and the flow controller (FC N2).

3. Results

Natural gas is a fossil fuel that is gaining an increasingly significant portion of the global energy matrix. This change is due to the technical and economic benefits provided by the use of this energy source. Natural gas is cheaper than other sources of fossil fuels and reduces the costs associated with maintenance. As for the environmental aspects, the use of natural gas as a form of energy brings benefits such as reductions in sulfur dioxide (SO₂), nitrogen oxides (NO_x), particulate matter and carbon dioxide (CO₂). The composition of natural gas is not consistent and varies with location (see Table 1) and gas supplier where different odorants are added.

Table 1 – Natural gas composition.

Composition (%V/V) of natural gas in different locations	North America #1	North America #2	Europe #1	Europe #2	Asia #1
Compound					
Methane (%)	95	95	89	67	89
Ethane (%)	3	3	5	0.5	5
Propane (%)	0.4	0.4	2	0.5	3.5
Butanes (%)	0.1	0.1	0.5	13	2.5
Carbon dioxide (%)	1	1	1	0.5	0
Nitrogen (%)	0.5	0.5	2.5	14.5	0
Oxygen (%)	0	0	0	4	0
DMS (ppmv)	0	2	0	0	6
TBM (ppmv)	3	4	0	0	5

THT (ppmv)	0	0	8	8	0
COS (ppmv)	0	1	2	2	0
H₂S (ppmv)	0	1	0.5	0.5	0
Other Mercaptans (ppmv)	1	0	0.1	0.1	0

The concentration and the elution time of the peaks for the isomers identified in the natural gas are reported in Fig.2 and Table 2. Peaks for C₄H₈, C₂H₆O, C₇H₈, C₂H₄O₂ and C₁₀H₁₄ are reported in figure 2. The highest ions extraction rate was identified for C₄H₈ with the first peak that eluted from the column at 15 s. At 23 s and at 116 s two other peaks are identified. In this condition at 57.07 g/mol it is possible to identify three isomers that can be tentatively identified with isobutene, cyclobutane and methylcyclopropane [9].

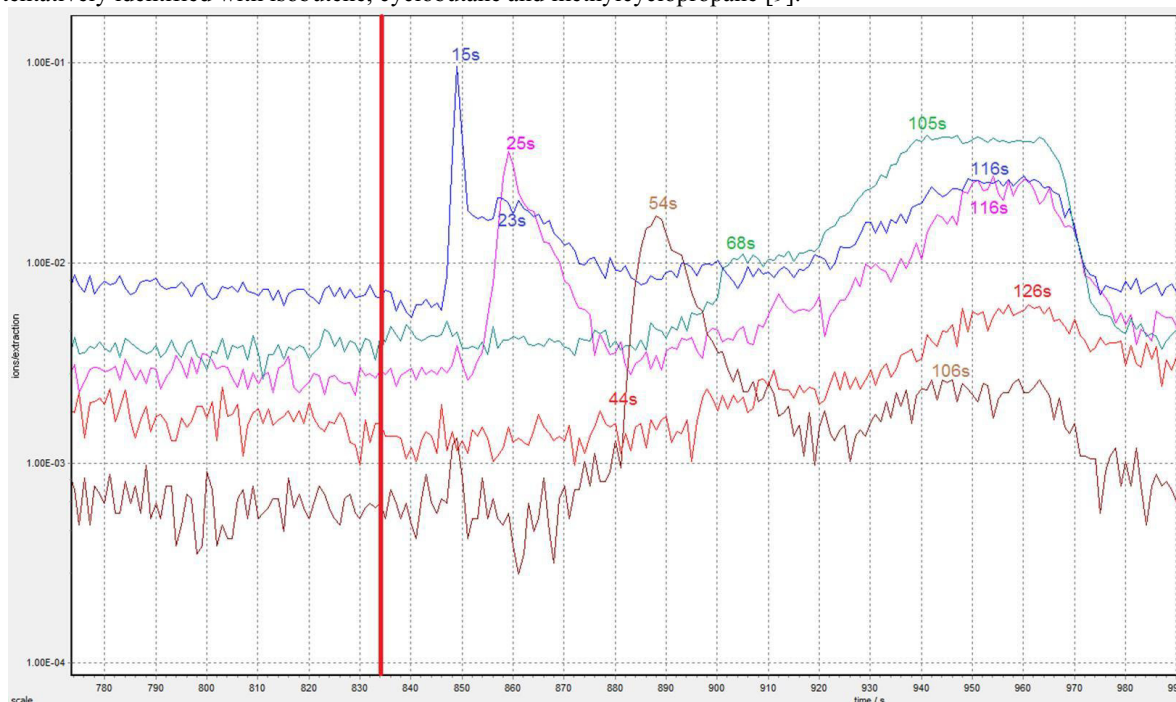

Figure 2 – Natural gas isomers identification for some trace compounds: blue) C₄H₈, pink) C₂H₆O, brown) C₇H₈, green) C₂H₄O₂, red) C₁₀H₁₄.

Mass at 93.07 g/mol (C₇H₈) showed two peaks that identify two isomers compounds. The elution time was recorded at 54 s and 106 s. The possible isomers detected could be toluene, cycloheptadiene, norbornadiene, 6methylfulvene and norbornadiene that are representatives of hydrocarbon and aromatic compounds [9]. At mass 61.03 g/mol organic compound isomers are identified, may be acetic acid, methylformate, ethenediol and others. Other isomers are reported in table 2, the most important ones for the natural gas content are hydrocarbons and sulfur compounds.

In detail the main compounds are:

- Hydrocarbons, mainly C₃H₄ (probably propyne, allene and cyclopropene that elute at 15 s, 59 s and 104 s), C₅H₁₀ (probably cyclopentane, 2methylbutene and pentene that elute at 15 s, 64 s and 101 s), C₆H₆ (probably benzene, fulvene and cyclohexadiene), C₇H₈ (probably toluene cycloheptatriene that elute at 54 s and 106 s) and C₇H₁₂ (probably norbornane and cycloheptene that elute at 25 s and 106 s);
- Sulfur compounds, mainly C₄H₈S (probably tetrahydrothiophene and allylmethylsulfide that elute at 48 s and 106 s) and C₄H₁₀S (probably tertbutyl mercaptan and butanethiol that elute at 65s and 106 s).

Table 2 – Natural gas main isomers identified with PTR-ToF-MS - FastGC.

Possible isomers detected (Nist[9])	Chemical formula	MWH ⁺ (g/mol)	ppb(v)	Time (s) for peaks identification			
				1.00	2.00	3.00	4.00
methanol	CH4O	33.03	3.00	15.00	27.00	39.00	106.00
propyne, allene, cyclopropene	C3H4	41.04	961.35	15.00	59.00	104.00	
ethanol, dimethyl ether	C2H6O	47.05	0.01	25.00	116.00		
isobutene, 1butene, 2butene, cyclobutane, methylcyclopropane	C4H8	57.07	20.39	15.00	23.00	116.00	
acetone, propionaldehyde, allyl alcohol, oxetane, propylene oxide, epoxypropane, methyl vinyl ether, 2propenol, 1propenol	C3H6O	59.05	143.58	46.00	105.00		
acetic acid, methylformate, glycolaldehyde, dioxetane, 1,2ethenediol, ethenediol, 1,3 dioxetane, 2oxiranol, vinylhydroperoxide, 3methyl dioxirane	C2H4O2	61.03	39.44	68.00	105.00		
isoprene, cyclopentene, pentyne, transpipericycene, 2pentyne, 1,4pentadiene, 1,1dimethylallene	C5H8	69.07	388.43	27.00	63.00	107.00	
cyclopentane, 2methylbutene, 3methylbutene, pentene, ethylcyclopropane, 1,2 dimethylcyclopropane, pentane	C5H10	71.08	811.40	15.00	64.00	101.00	
2 butanone, tetrahydrofuran, butyraldehyde, isobutyraldehyde, cyclobutanol, 2metoxypropene, propionic acid, methyl acetate, ethyl formate, 3hydroxypropanol, lactaldehyde, methoxyacetaldehyde, hydroxyacetone, propenediol, glycidol acetol	C4H8O	73.06	40.65	57.00	120.00		
benzene, hexadiyne, fulvene, divinylacetylene, benzvalene, prismane, bicyclopentenyl, cyclohexadiene, phenylium, cyclohexadiene	C6H6	79.05	988.93	81.00	107.00		
cyclopentenone, cyclopentenone, 2methylfuran, 3cyclopentenone, 4hpyran, 2pentyne, 4pentyne, 3 methylenecyclobutanone	C6H8	81.07	28.99	64.00	116.00		
cyclohexene, cyclohexene, dimethylbutadiene, hexyne, tbutylacetylene	C5H6O	83.05	0.60	47.00	96.00		
cyclohexane, cyclohexane, tetramethylethylene, hexane, methylcyclopentane, 4methylpentene, 2,3dimethylbutene	C6H10	83.08	429.58	50.00	111.00		
tetrahydrothiophene, allylmethylsulfide, cyclobutanethiol, butanethiol	C6H12	85.10	646.43	18.00	115.00		
tertbutyl mercaptan, butanethiol, ethylsulfide, tert butanethiol	C4H8S	89.04	10006.94	48.00	106.00		
toluene, cycloheptatriene, norbornadiene, 1,6heptadiyne, quadricyclane, 6methylfulvene	C4H10S	91.05	66.43	65.00	106.00		
norbornane, cycloheptene, heptyne, 1methylcyclohexene, methylenecyclohexane, norcarane	C7H8	93.07	710.40	54.00	106.00		
xylene, ethylbenzene, oxylene, pxylylene, mxylylene, 6,6dimethylfulvene, 1ethynylcyclohexene	C7H12	97.10	639.08	25.00	106.00		
cyclooctene, allylcyclopentane, octyne, methylstyrene, indane, allylbenzene, 4vinyltoluene, propenylbenzene	C8H10	107.09	152.71	60.00	125.00		
pymene, butylbenzene, durene, diethylbenzene, tetramethylbenzene	C8H14	111.12	306.50	60.00	121.00		
monoterpene, apinene, bpinene, limonene, 3carene	C9H10	119.09	12.79	64.00	85.00	108.00	
	C10H14	135.12	6.77	44.00	126.00		
	C10H16	137.13	7.94	65.00	120.00		

4. Conclusions

The main trace compounds detected analyzing natural gas are related to the hydrocarbon family, sulfur compounds and organic compounds. The highest concentration detected is related to the hydrocarbons followed by sulfur compounds, with THT. The main isomers detected are still related to the hydrocarbons and sulfur compounds. Propyne, allene and cyclopropene were tentatively identified at C3H4, while tetrahydrothiophene and allylmethylsulfide were tentatively identified at C4H8S.

Acknowledgements

This work has been funded by the BWS project (Biowaste for SOFCs); project funded by the Fondazione Cassa di Risparmio di Trento e Rovereto.

References

- [1] Hagen A, Hendriksen P V, Frandsen HL, Thydén K, Barfod R. Durability Study of SOFCs Under Cycling Current Load Conditions 2009;814–22. doi:10.1002/fuce.200900013.
- [2] Papurello D, Lanzini A, Tognana L, Silvestri S, Santarelli M. Waste to energy: Exploitation of biogas from organic waste in a 500 Wel solid oxide fuel cell (SOFC) stack. *Energy* 2015;85:145–58. doi:10.1016/j.energy.2015.03.093.
- [3] Papurello D, Lanzini A, Drago D, Leone P, Santarelli M. Limiting factors for planar solid oxide fuel cells under different trace compound concentrations. *Energy* 2016;95:67–78. doi:10.1016/j.energy.2015.11.070.
- [4] Cappellin L, Karl T, Probst M, Ismailova O, Winkler PM, Soukoulis C, et al. On quantitative determination of volatile organic compound concentrations using proton transfer reaction time-of-flight mass spectrometry. *Environ Sci Technol* 2012;46:2283–90. doi:10.1021/es203985t.
- [5] Jordan A, Haidacher S, Hanel G, Hartungen E, Märk L, Seehauser H, et al. A high resolution and high sensitivity proton-transfer-reaction time-of-flight mass spectrometer (PTR-TOF-MS). *Int J Mass Spectrom* 2009;286:122–8. doi:10.1016/j.ijms.2009.07.005.
- [6] Romano A, Fischer L, Herbig J, Campbell-Sills H, Coulon J, Lucas P, et al. Wine analysis by FastGC proton-transfer reaction-time-of-flight-mass spectrometry. *Int J Mass Spectrom* 2014;369:81–6. doi:10.1016/j.ijms.2014.06.006.
- [7] Beghi S, Guillot J-M. Use of poly(ethylene terephthalate) film bag to sample and remove humidity from atmosphere containing volatile organic compounds. *J Chromatogr A* 2008;1183:1–5. doi:10.1016/j.chroma.2007.12.051.
- [8] Hansen MJ, Adamsen APS, Feilberg A, Jonassen KEN. Stability of odorants from pig production in sampling bags for olfactometry. *J Environ Qual* 2011;40:1096–102. doi:10.2134/jeq2010.0497.
- [9] Coblenz Society Inc. NIST Chemistry WebBook. NIST Chem WebBook, NIST Stand Ref Database Number 69 n.d. <http://webbook.nist.gov>.