

External Metrology System for the Stabilization of Large Ring-Lasers

*Original*

External Metrology System for the Stabilization of Large Ring-Lasers / Donazzany, Alberto; Nalettoyz, Giampiero; Pelizzozy, Maria Guglielmina; Cuccatoy, Davide; Beghiy, Alessandro; Ortolanx, Antonello; Belfi, Jacopo; Bosi, Filippo; Virgilio, Angela Di; Beverinik, Nicol`o; Carellik, Giorgio; Maccionik, Enrico; Santagatak, Rosa; Simonellixi, Andreino; Porziyyx, Alberto; Tartaglia, Angelo. - ELETTRONICO. - (2016), pp. 266-270. (Intervento presentato al convegno Metrology for Aerospace tenutosi a Florence, Italy nel 22-23 June 2016).

*Availability:*

This version is available at: 11583/2664167 since: 2017-01-30T13:33:47Z

*Publisher:*

IEEE

*Published*

DOI:

*Terms of use:*

This article is made available under terms and conditions as specified in the corresponding bibliographic description in the repository

*Publisher copyright*

(Article begins on next page)

# External Metrology System for the Stabilization of Large Ring-Lasers

Alberto Donazzan<sup>\*†</sup>, Giampiero Naletto<sup>\*†‡</sup>, Maria Guglielmina Pelizzo<sup>†‡</sup>, Davide Cuccato<sup>\*†</sup>,  
Alessandro Beghi<sup>\*†</sup>, Antonello Ortolan<sup>§</sup>, Jacopo Belfi<sup>¶</sup>, Filippo Bosi<sup>¶</sup>, Angela Di Virgilio<sup>¶</sup>,  
Nicolò Beverini<sup>||</sup>, Giorgio Carelli<sup>||</sup>, Enrico Maccioni<sup>||</sup>, Rosa Santagata<sup>||\*\*</sup>, Andreino Simonelli<sup>xi¶</sup>,  
Alberto Porzio<sup>††x</sup> and Angelo Tartaglia<sup>†‡</sup>

<sup>\*</sup> Department of Information Engineering, Università di Padova, I-35131 Padova, Italy

Email: alberto.donazzan@dei.unipd.it

<sup>§</sup> INFN – Laboratori Nazionali di Legnaro, I-35020 Legnaro (PD), Italy

<sup>†</sup> INFN – Sezione di Padova, I-35131 Padova, Italy

<sup>¶</sup> INFN – Sezione di Pisa, I-56127 Pisa, Italy

<sup>x</sup> INFN – Sezione di Napoli, I-80126 Napoli, Italy

<sup>‡</sup> CNR-IFN – Sezione di Padova, I-35131 Padova, Italy

<sup>††</sup> CNR-SPIN – Sezione di Napoli, I-80126 Napoli, Italy

<sup>||</sup> Department of Physics, Università di Pisa, I-56127 Pisa, Italy

<sup>\*\*</sup> Department of Physics, Università di Siena, I-53100 Siena, Italy

<sup>††</sup> Department of Applied Science and Technology, Politecnico di Torino, I-10129 Torino, Italy

<sup>xi</sup> Ludwig-Maximilians-Universität München, D-80333 München, Germany

**Abstract**—Active control of the geometrical parameters of large ring-lasers arrays is a challenging task, requiring the development of an accurate length monitoring system acting on the edges of these devices. The proposed solution is based on what was outlined by NASA JPL for its discontinued Space Interferometric Mission (SIM). It will be made up of a network of compact laser heterodyne interferometers, working together to keep the geometrical frame constantly well known (and fixed) to nanometer accuracy. We took the first steps towards the realization of this device by focusing on its fundamental element, i.e. the compact heterodyne laser interferometer. A starting simplified prototype has been conceived and is now under development. Its preliminary design will let us to evaluate parts behavior, alignment issues and links between single components and overall gauge performances. Concerned distance is investigated by means of a reference and a measurement beam, obtained by spatial splitting of the laser source. The phase shift between two heterodyne beatings will provide a reliable signal for precise monitoring of a linear distance.

## I. INTRODUCTION

Large size ring-laser gyroscopes based on the Sagnac effect are reaching increasingly higher sensitivities, already allowing for outstanding geodetic measurements [1], [2]. GINGER (Gyroscopes IN General Relativity) is an experiment proposal for the measurement, by means of large ring-lasers, of a very weak relativistic effect produced by the Earth's rotating mass [3], [4]. This effect, known as inertial frame dragging, or “Lense-Thirring effect” (LT), is predicted by General Relativity and was studied by Lense and Thirring [27] in 1918 for the case of the weak gravitational field of a slowly rotating body. A direct experimental evidence of the Earth induced frame dragging has been obtained so far by the data collected from laser ranged Earth-orbiting satellites

such as LAGEOS (LAsER GEodynamics Satellite), LAGEOS 2 and LARES (Laser Relativity Satellite) and from the dedicated space mission Gravity Probe B (GP-B), launched by NASA in 2004 after more than 30 years of research and development. Five years of data analysis allowed the GP-B group to measure the LT effect with an uncertainty of 19% [5]. With precise Satellite Laser Ranging (SLR) the same value was confirmed with approximately 10% accuracy, using LAGEOS, LAGEOS 2 and the Earth's gravity field determinations by the space geodesy mission GRACE [6]. A recent publication reports an improved accuracy of 5%, based on LAGEOS, LAGEOS 2 and LARES orbit data over a 3.5 years period [7].

All these results have been achieved thanks to freely falling objects orbiting around Earth and required years of data analysis and orbits averaging in order to extract a reliable value from all systematics and random errors. GINGER will represent a completely different approach, as it will detect the frame dragging effect in a ground-based laboratory, providing measurements in local space and time. Indeed, the LT effect will be determined at the laboratory location in a few days of signal integration.

## II. THE GINGER EXPERIMENT

GINGER will consist of an array of at least three mutually orthogonal square ring-lasers (6-10 m in side), arranged in a cubic or octahedral configuration. The tri-axial design will provide a complete estimation of the laboratory frame angular velocity, to be compared with the Earth's rotation estimate provided by IERS (International Earth Rotation and Reference Systems Service) with respect to the fixed stars frame. GINGER will be located in a deep underground site, possibly the

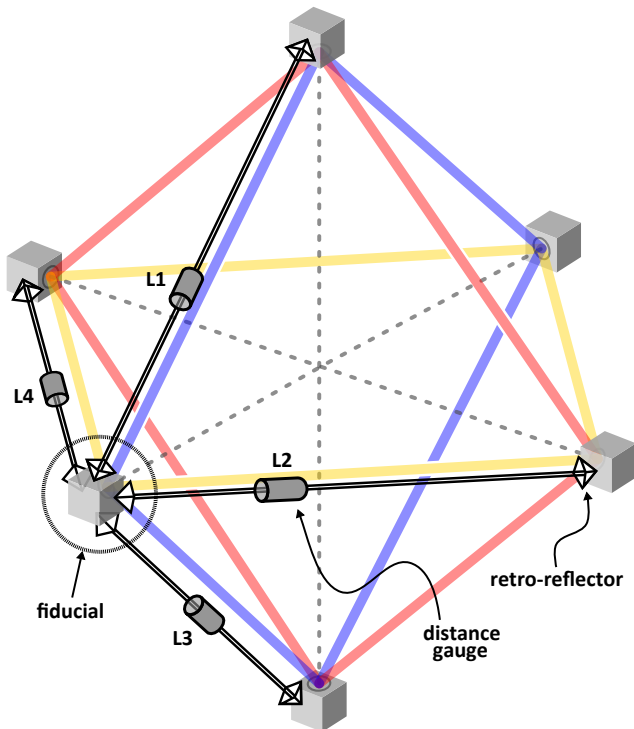

Fig. 1. Simplified structure of the external metrology truss matched with GINGER (octahedral version).

INFN - National Laboratories of Gran Sasso, which is now housing a site characterization prototype called GINGERino.

The required accuracy for Lense-Thirring effect measurements is better than  $10^{-14} \text{ rad/s}$  and therefore Earth angular velocity must be measured within one part in  $10^9$ . As previous experience on rigid ring-lasers has already demonstrated, ring-lasers with a passive stabilization of the cavity geometry do not allow to achieve the extremely high accuracy required for General Relativity tests, even in the most performing condition obtained with the “G” ring-laser in Wettzell [8]. To overcome this problem, GINGER will require an active control system, capable of compensating possible nanometer variations in the system geometry during every long lasting measurement of Earth’s rotation rate. This need for active control of the geometrical parameters of a ring-laser array, within such strictly binding specifications [3], translates in the need for a real-time monitor of the ring-lasers’ edge lengths, i.e. of the distances between all their mirrors.

The accuracy of a ring-laser measurement strongly depends on the ring’s geometry, that is, its output is directly proportional to the ratio  $A/P$ , where  $A$  is the area and  $P$  the perimeter of the ring. Therefore this ratio must be well known and actively stabilized for every ring of the array. Nevertheless, also the relative angles between different rings must be monitored, in order to properly reconstruct the angular velocity vector. The required accuracy for this additional task reaches the nano-radian level.

A control scheme for the geometrical factor of a single ring is at the moment under development and test at INFN of

Pisa with a prototype called GP2 [9]. Monitoring of relative angles between different rings was originally based on higher order modes of the ring cavity [3], but it was then realized that an independent metrology technique had to be developed, something independent of any ring-laser dynamics. Therefore a third approach, based on an external metrology system is now under development. This metrology system will be closely matched to the main instrument, providing real-time measurements of its geometrical frame and acting as the first element of a feedback control loop. Moreover, this external metrology could be applied both to the control of each ring and to the monitoring of the angles between different rings.

The best real world example of this alternative technique is represented by the “External Metrology Truss” [10], [11] devised by NASA’s Jet Propulsion Laboratory (JPL) for its discontinued Space Interferometric Mission [12]. This device was supposed to provide reliable distance measurements for the accurate monitoring of the baseline length of a stellar interferometer aimed to planet finding. The truss was made up of a network of laser heterodyne interferometers, working together to keep the spacecraft geometry constantly well known to the  $10 \text{ pm}$  precision. A common light source was provided by a fiber coupled  $1319 \text{ nm}$  Nd:YAG DPSS laser. Source light was split in half and each part sent to an acousto-optic modulator, where a frequency offset was introduced between the halves: a reference and a measurement beam were created in this way and, after proper splitting, sent to every interferometer via PM optical fibers. Each interferometer (beam-launcher) layed on a compact and portable Zerodur<sup>®</sup> base, where all the optics were firmly fixed. This breadboard was placed between two of the many fiducials laying on the spacecraft. The fiducials were made by multiple corner-cube retro-reflectors, rigidly connected to appropriate reference points of the truss to be monitored. Single distance measurements were retrieved by detecting the phase shift between two heterodyne beatings: the reference beating, generated by direct recombination of the source lights, and the measurement beating, generated by recombination between the source light and the measurement beam, which had travelled along a racetrack between the fiducials. Together with this main displacement monitoring system, there existed some other subsystems working to provide additional features and reliability:

- a frequency tuning system for the laser source, devoted to two-colors interferometry for the determination of the absolute distance between the fiducials [10];
- a pointing dithering system which protected against misalignments of the interferometer with respect to the axis ideally connecting the fiducials [13].

For a detailed description of the beam launcher we refer to [14].

### III. FULL SYSTEM CONCEPT: LOCKING AN ARRAY OF RING-LASERS

Basically, the idea is to adapt this concept to the case of GINGER, which will then rely on an effective geometry monitoring system. Moreover, this external metrology system

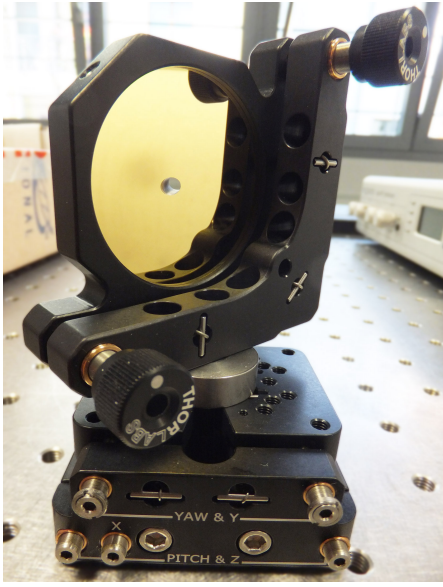

Fig. 2. Back side view of a 2in double sided gold mirror with a 45° central hole; the mirror is mounted on a x-y-z translator for alignment purposes.

will send its data to a feedback control loop, whose actuators will be multi-axial piezo-electric translational stages carrying all the ring-laser mirrors.

If for example an octahedral shape is chosen for GINGER, every fiducial (one for each vertex) could be ideally composed by a single bulk substrate featuring both the ring-laser super-mirror, which is shared by 3 ring-lasers, and 4 corner retro-reflectors, one for each edge leaving from the given vertex. Then the external metrology truss would be ideally set up by placing 12 compact distance gauges along the corresponding edges of the octahedron (see Figure 1). A dedicated vacuum system will be necessary to guarantee measurements independent of any ring-laser dynamics. Extremely precise manufacturing of the fiducials will be essential as well, together with their geometrical characterization.

Moreover, depending on the number of available interferometers and the type of physically craftable fiducials (either simple one-direction backreflectors, or multidirectional ones), an array of cross measurements can be realized to over-constrain the “rigidity” of the ring-laser array. Then, thanks to a detailed mathematical model of the ring-laser geometry and a multivariable control scheme, it will be possible to drive suitable nano-positioning actuators to properly move the mirrors and actively control all the relevant dimensions of the cavities. In such a way, it will be possible to keep GINGER’s geometry locked within the required accuracy, independently of any environmental disturbances.

The first step towards the realization of this device is the construction of its fundamental element, i.e. the compact heterodyne laser interferometer.

#### IV. SINGLE GAUGE PROTOTYPE DESIGN

The first working example of a distance gauge for GINGER will be a simplified prototype: its preliminary design will

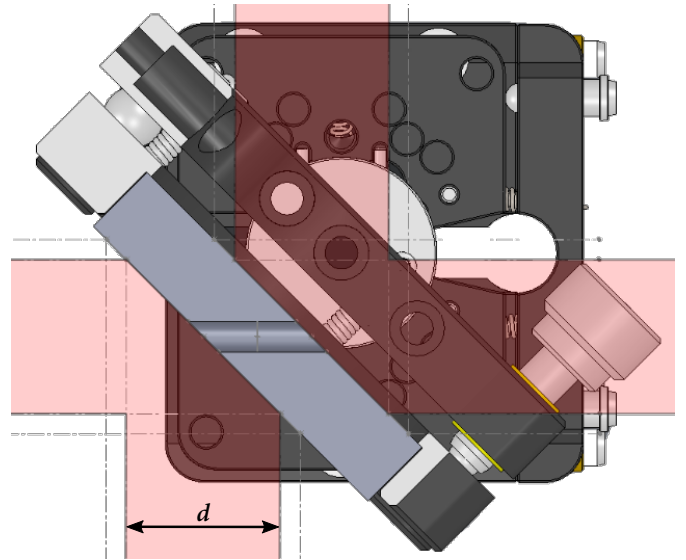

Fig. 3. Up view of the mirror 3D model, together with a representation of the racetrack beams hitting the mirror on both sides. The current mirror-mount configuration allows for a maximum beam diameter  $d = 15\text{ mm}$ .

let us evaluate parts behavior, alignment issues and links between single components and overall system performances. The prototype will lie on a vibration isolated optical table and work in a standard air environment, certainly without claim to reach the final desired precision. The goal for this first step is to be able to measure relative shifts between fiducials with sub-micron precision.

The prototype’s optical design mostly follows what was conceived for SIM, at least with respect to its basic working principle and the means of splitting between reference and measurement beams. Source light comes from a continuous wave Nd:YAG DPSS laser featuring a  $> 1\text{ km}$  coherence length and analog frequency tunability; its  $1064\text{ nm}$  beam is fiber coupled right after exiting the device and routed to a 50:50 fiber splitter by means of polarization-maintaining (PM) single mode fibers. Each half is then sent to a in-fiber acousto-optic modulator which shifts its optical frequency by respectively  $150\text{ MHz}$  and  $150\text{ MHz} + \Delta f$ , where  $\Delta f$  can be tuned in the range from  $0\text{ Hz}$  to about  $10\text{ MHz}$ . Finally, both beams travel through refractive fiber collimators and are ready to proceed across the free-space section of the distance gauge. The simplified optical schematic of a single interferometer is showed in Figure 4.

##### A. The racetrack

Spatial separation between measurement and reference beams is provided by a gold-coated double mirror, operating at 45° angle of incidence. A 3D model of this mirror showed non trivial footprint issues due to the 45° incidence angle and the necessity to keep a wide enough clear aperture on both sides of the mirror (see Figure 3). We chose a 2in diameter in order to avoid beam shading by mounts. The 45° tilted hole lets the reference beam walk through and reach the recombination beam-splitter (beam-combiner) immediately after; instead, the

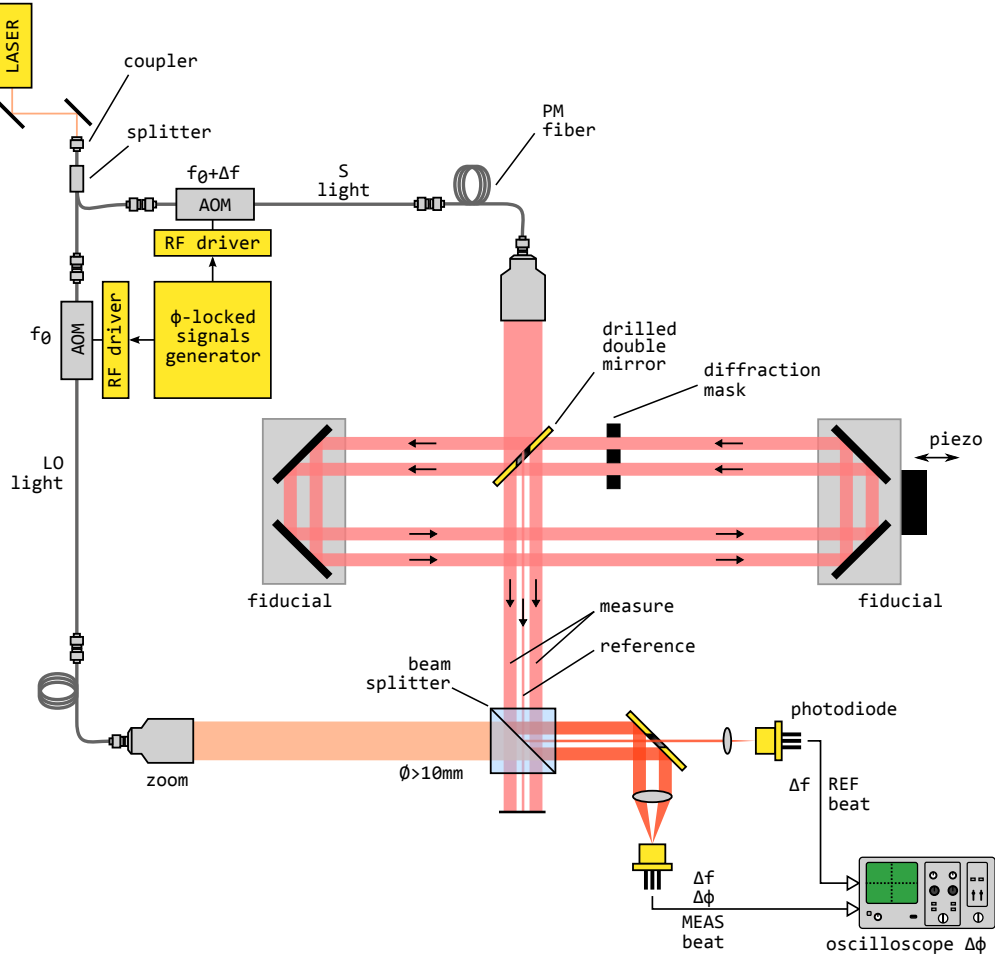

Fig. 4. Schematic of the distance gauge prototype.

annular part of the beam is sent along the racetrack, made up by the drilled mirror itself and 4 auxiliary gold mirrors. These additional gold mirrors are set up in two prealigned fixed pairs, as to form two 2D retro-reflectors which will act as distance fiducials; one of them is placed on a nano-positioning translational stage in order to carry out performance tests of the prototype. Furthermore, we plan to place properly shaped masks along the 8 m test distance for a better spatial isolation of the reference and measurement beams, given that a mixing of them badly compromises the distance measurements.

### B. The heterodyne interferometer

Except for the so called “racetrack”, the setup is similar to that of a standard Mach-Zehnder interferometer. Actually this is the optical path that the reference beams (central part of each source beam) follow before recombining and giving birth to a reference light beating at frequency  $\Delta f$ . The measurement beam is picked out by means of the double sided mirror. As already mentioned, this mirror spatially splits one of the source beams in two parts: the inner part, propagating straight through the hole along the Mach-Zehnder path, and the outer part, with a ring shaped section, hitting the mirror and travelling along the racetrack. In fact, this beam measures the distance between

the fiducials by making a loop: the beam goes to the first fiducial (on the left) and hits it off-center; the reflected beam is offset and goes past the gauge to hit the second fiducial on the right; then the beam is reflected and offset a second time and lines up again with the double-sided mirror; finally the beam hits the back side of the drilled mirror and proceeds down to the beam-combiner. With respect to its reference counterpart, the beam travelling along the racetrack gathers a phase delay  $\phi$  directly proportional to the relative displacement between the fiducials  $\Delta L$ :

$$\phi = \frac{2\pi}{\lambda} \cdot 2\Delta L$$

where  $\lambda$  is the optical wavelength of the laser source. A measurement light beating is therefore generated by the recombination between the outer parts of the source beams. We recall that the reference and measurement lights are spatially separated, reducing the risk of signals intermixing if compared to polarized light solutions [14].

A second drilled mirror provides for the deflection of the measurement beating on a detector different from the reference one. Both of these detectors are transimpedance amplified photodiodes with switchable gain and their generated voltage

signals are sent to an oscilloscope, on which first rough phase measurements will be performed. A suitable digital phasemeter will be used for high resolution sampling.

## V. CONCLUSION

A space-borne 3D metrology system has been studied and virtually tailored for the binding specifications of a ground-based array of large ring-lasers, devoted to detecting the Lense-Thirring effect, a thin relativistic effect produced by the rotation of planet Earth. Experimental work is now focusing on assembly and test of a single heterodyne distance gauge, with the goal of improving its accuracy down to the nanometer level in less than a year. Investigation of several key issues is underway as well: single gauge mechanical design, oriented towards compactness and reproducibility; design, manufacturing and characterization of multidirectional fiducials; geometry modeling and control scheme design for the stabilization of the full system. We are then faced with many challenges, which will require hard work and complex technological solutions in order to bring large ring-lasers in the realm of General Relativity tests.

## REFERENCES

- [1] K. U. Schreiber, T. Klügel, J.-P. R. Wells, R. B. Hurst, and A. Gebauer, "How to detect the Chandler and the annual wobble of the earth with a large ring laser gyroscope," *Physical Review Letters*, vol. 107, p. 173904, Oct 2011.
- [2] K. U. Schreiber, A. Gebauer, and J.-P. R. Wells, "Closed-loop locking of an optical frequency comb to a large ring laser," *Optics Letters*, vol. 38, p. 3574, Sep. 2013.
- [3] F. Bosi, G. Cella, A. Di Virgilio, A. Ortolan, A. Porzio, S. Solimeno, M. Cerdonio, J. P. Zendri, M. Allegrini, J. Belfi, N. Beverini, B. Bouhadef, G. Carelli, I. Ferrante, E. Maccioni, R. Passaquieti, F. Stefani, M. L. Ruggiero, A. Tartaglia, K. U. Schreiber, A. Gebauer, and J.-P. R. Wells, "Measuring gravitomagnetic effects by a multi-ring laser gyroscope," *Physical Review D*, vol. 84, p. 122002(23), 2011.
- [4] A. Di Virgilio, M. Allegrini, A. Beghi, J. Belfi, N. Beverini, F. Bosi, B. Bouhadef, M. Calamai, G. Carelli, D. Cuccato, M. Maccioni, A. Ortolan, G. Passeggio, A. Porzio, M. L. Ruggiero, R. Santagata, and A. Tartaglia, "A ring lasers array for fundamental physics," *Comptes Rendus Physique*, vol. 15, no. 10, pp. 866–874, 2014.
- [5] C. W. F. Everitt, D. B. DeBra, B. W. Parkinson, J. P. Turneaure, J. W. Conklin, M. I. Heifetz, G. M. Keiser, A. S. Silbergleit, T. Holmes, J. Kolodziejczak, M. Al-Meshari, J. C. Mester, B. Muhlfelder, V. G. Solomonik, K. Stahl, P. W. Worden, W. Bencze, S. Buchman, B. Clarke, A. Al-Jadaan, H. Al-Jibreen, J. Li, J. A. Lipa, J. M. Lockhart, B. Al-Suwaidan, M. Taber, and S. Wang, "Gravity probe b: Final results of a space experiment to test general relativity," *Physical Review Letters*, vol. 106, p. 221101, May 2011.
- [6] I. Ciufolini and E. C. Pavlis, "A confirmation of the general relativistic prediction of the lense-thirring effect," *Nature*, vol. 431, pp. 958–960, Oct. 2004.
- [7] I. Ciufolini, A. Paolozzi, E. C. Pavlis, R. Koenig, J. Ries, V. Gurzadyan, R. Matzner, R. Penrose, G. Sindoni, C. Paris, H. Khachatryan, and S. Mirzoyan, "A test of general relativity using the LARES and LAGEOS satellites and a GRACE Earth gravity model. Measurement of Earth's dragging of inertial frames," *European Physical Journal C*, vol. 76, p. 120, Mar. 2016.
- [8] K. U. Schreiber and J. P. R. Wells, "Invited review article: Large ring lasers for rotation sensing," *Review of Scientific Instruments*, vol. 84, pp. 041101–, 2013.
- [9] J. Belfi, N. Beverini, M. Calamai, G. Carelli, E. Maccioni, A. Di Virgilio, R. Santagata, A. Porzio, D. Cuccato, A. Ortolan, and S. Solimeno, "Absolute control of the scale factor in gp2 laser gyroscope: Toward a ground based detector of the lense-thirring effect," in *European Frequency and Time Forum & IEEE International Frequency Control Symposium (EFTF/IFC), 2013 Joint*, 2013, pp. 795–798.
- [10] P. G. Halverson, A. Kuhnert, J. Logan, M. Regehr, S. Shaklan, R. Spero, F. Zhao, and T. Chang, "Progress towards picometer accuracy laser metrology for the space interferometry mission," in *Proceedings of ICSO 2000, 4th International Conference on Space Optics*. NASA JPL, 2000, pp. 417–428.
- [11] P. G. Halverson, O. Alvarez-Salazar, A. Azizi, F. Dekens, B. Nemati, and F. Zhao, "Progress towards picometer accuracy laser metrology for the space interferometry mission - update for ics0 2004," in *Proceedings of ICSO 2004, 5th International Conference on Space Optics*. NASA JPL, 2004, pp. 515–522. [Online]. Available: <http://adsabs.harvard.edu/abs/2004ESASP.554..515H>
- [12] B. Nemati, "Sim planetquest: Status and recent progress," in *Proceedings of SPIE: Advances in Stellar Interferometry*, vol. 6268. NASA JPL, 2006.
- [13] J. E. Logan, P. G. Halverson, M. W. Regehr, and R. E. Spero, "Automatic alignment of a displacement-measuring heterodyne interferometer," *Applied Optics*, vol. 41, pp. 4314–4317, 2002.
- [14] L. B. Ames, B. Barrett, R. Bell, L. Dries, K. Dutta, P. G. Halverson, B. Holmes, E. T. Kvamme, D. F. Leary, P. Perkins, M. Scott, T. E. Van Eck, and F. Zhao, "Sim external metrology beam launcher (qp) development," in *Proceedings of SPIE: Interferometry in Space*, vol. 4852. NASA JPL, 2003, pp. 347–354.