

FPGA Implementation of DWT EEG Data Compression for Wireless Body Sensor Networks

Original

FPGA Implementation of DWT EEG Data Compression for Wireless Body Sensor Networks / Badawy, A.M.H.B.M., Massudi, M., Tarek, E., Amr, M., Khalid, A.. - STAMPA. - (In corso di stampa). (2016 IEEE Conferemce on Wireless Sensors).

Availability:

This version is available at: 11583/2664160 since: 2017-01-31T11:21:29Z

Publisher:

IEEE

Published

DOI:

Terms of use:

This article is made available under terms and conditions as specified in the corresponding bibliographic description in the repository

Publisher copyright

IEEE postprint/Author's Accepted Manuscript

©9999 IEEE. Personal use of this material is permitted. Permission from IEEE must be obtained for all other uses, in any current or future media, including reprinting/republishing this material for advertising or promotional purposes, creating new collecting works, for resale or lists, or reuse of any copyrighted component of this work in other works.

(Article begins on next page)

FPGA Implementation of DWT EEG Data Compression for Wireless Body Sensor Networks

Mohamed Elsayed*, Ahmed Badawy*[†], Massudi Mahmuddin[§],
Tarek Elfouly[‡], Amr Mohamed [‡] and Khalid Abualsaud[‡]

* Qatar University, Electrical Engineering Dept. (hamid, badawy@qu.edu.qa)

[†] Politecnico di Torino - DET (ahmed.badawy@polito.it)

[‡] Qatar University, Computer Science and Computer Engineering Dept. (tarekfouly, amrm, k.abualsaud@qu.edu.qa)

[§] University Utara Malaysia, Computer Science Dept., Graduate School of Computing (ady@uum.edu.my)

Abstract—Wireless body sensor networks (WBSN) provide an appreciable aid to patients who require continuous care and monitoring. One key application of WBSN is mobile health (mHealth) for continuous patient monitoring, acquiring vital signs e.g. EEG, ECG, etc. Such monitoring devices are doomed to be portable, i.e., batter powered, and agile to allow for patient mobility, while providing sustainable, energy-efficient hardware platforms. Hence, EEG data compression is critical in reducing the transmission power, hence increase the battery life. In this paper, we design and implement a complete hardware model based on discrete wavelet transform (DWT) for vital signs data compression and reconstruction on a field programmable gate array (FPGA) based platform. We evaluate the performance of our DWT compression FPGA implementation under different practical parameters including filter length and the compression ratio. We investigate the hardware and computational complexity of our design in terms of used resource blocks for future comparison with state-of-the-art techniques. Our results show the efficiency of the proposed hardware compression and reconstruction model at different system parameters, including the high pass filter coefficients, and DWT type, and DWT threshold.

Index Terms—WBSN, FPGA, EEG, ECG.

I. INTRODUCTION

Wireless body sensor network (WBSN), also referred to as body area network, comprises wearable sensors, typically in the form of probes that collect medical information and send it to the fusion center, also referred to as the network coordinator. WBSN modules can be embedded inside the human body or attached to it. WBSN monitor various vital signs and send them periodically to the networks coordinator to be ready for the medical care personnel. Research in WBAN has attracted a growing research recently. This due to the increasing number of patients with chronic diseases, who require an uninterrupted monitoring. WBSN allow remote monitoring of patients and hence enabling mobility, increased ability to avoid foreseen medical conditions as well as improved quality of medical care. Electrocardiogram (ECG) and electroencephalogram (EEG) monitoring devices are core WBSN technologies. EEG devices allow health care professionals to monitor and record electrical activity of the brain. Applications of EEG systems include detection and diagnosis of epileptic seizure, coma and brain death. With the recent technology trends, EEG

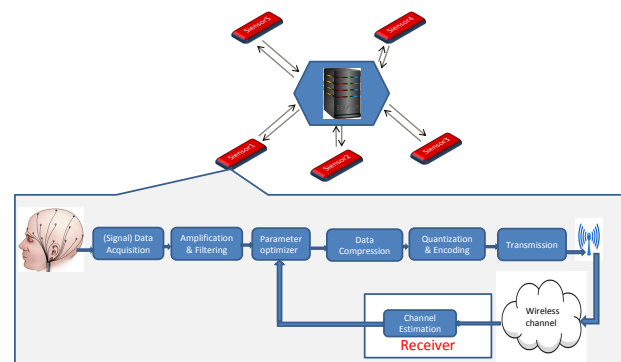

Fig. 1. Block diagram of WBSN architecture.

devices are highly desired to be portable and as tiny and non-intrusive as possible. The size of the battery of the portable EEG device determines the overall size as well as operational time. Therefore, data compression is paramount in any implementation of EEG systems [1] in order to reduce encoding and transmission powers, which are the two most preeminent elements limiting the life of the battery.

Several data compression techniques have been exploited within the context of EEG and ECG data, which can be categorized into two main categories.

- **Compressed sensing (CS) based:** In [2], the authors presented a framework for ECG data compression using compressed sensing. Their proposed solution has a low complexity that comes at the cost of poor performance when compared to wavelet transform based compression. In addition, within their proposed framework, limited control is provided over the encoder parameters, which causes their framework to lose the balance between power consumption and distortion rate. Practical implementation of CS data compression on scalp EEG signals is presented in [3], [4]. The authors investigated the reconstruction accuracy on different data sets. Although the data compression applied in the EEG module has low complexity, CS decoder has a high computational complexity, which may render the real-time implementation of the system.

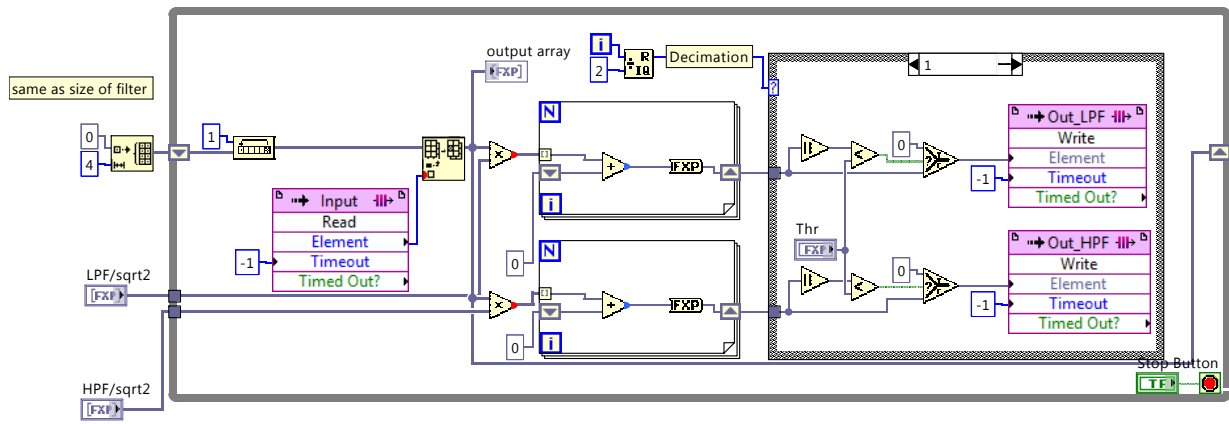

Fig. 2. Labview FPGA design of DWT compression: decimation and convolution.

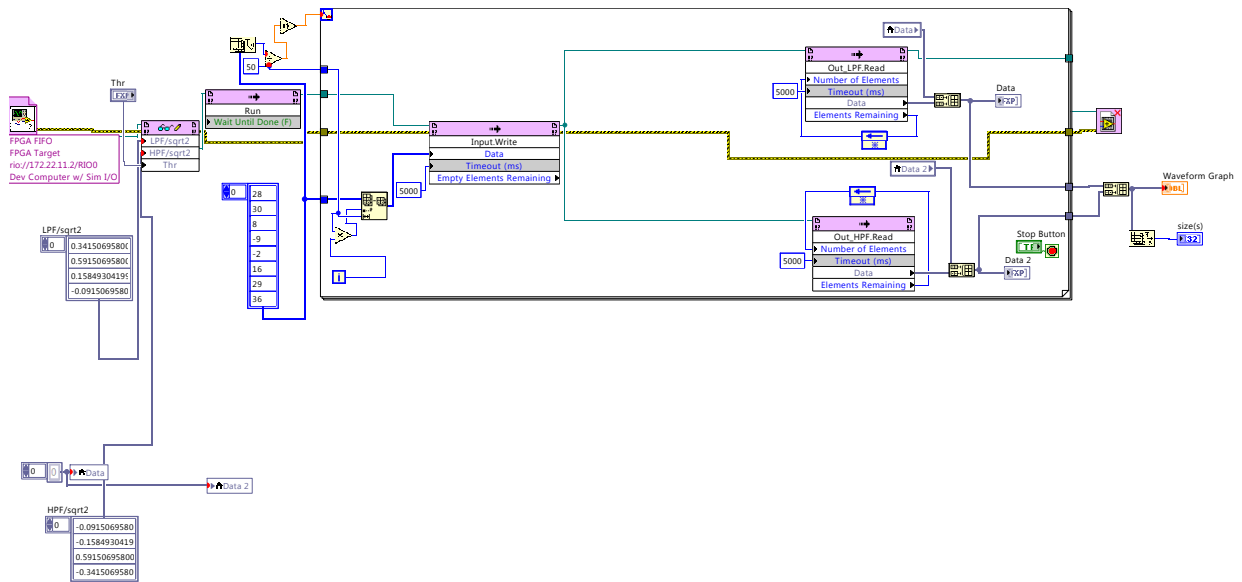

Fig. 3. Labview FPGA design of DWT compression.

The authors in [5] developed a CS framework for detection and classification of mother and fetal heartbeats using fetal-ECG signal. A thorough review on exploiting compressing sensing data for bioelectric data compression can be found in [6].

- **Discrete wavelet transform (DWT) based:** DWT data compression and reconstruction methods have high construction accuracy. EEG DWT data compression is presented in [7] as a lossless compression technique for EEG signal. However, because of the randomness of the EEG signal, high compression rates cannot be attained with lossless compression. The DWT based techniques presented [8], [9], [10], [11] provide the desired compromise between compression rate and residual distortion.

Extensive literature review shows a lack of hardware implementation of DWT EEG data compression, particularly real-time field programmable gate array (FPGA) implementation.

This is crucial for any future development or commercialization of EEG portable devices since it allows designers as well as academic researchers discover bottlenecks and implementation hurdles. Hence, develop new methods in order to tackle such problems.

Our contributions in this work as compared to existing literature are as follows. We design and implement an FPGA based real-time complete EEG data compression and reconstruction platform. We use real EEG data collected from [12]. We study the performance of our EEG data compression design under different filter length and for different compression ratios, which are the main parameters that affect distortion rate. We present the resource blocks used by the FPGA to implement the DWT compression algorithm.

As a matter of fact, our DWT FPGA implementation for data compression and reconstruction can be applied on other data types such as ECG. In the following, we apply our FPGA

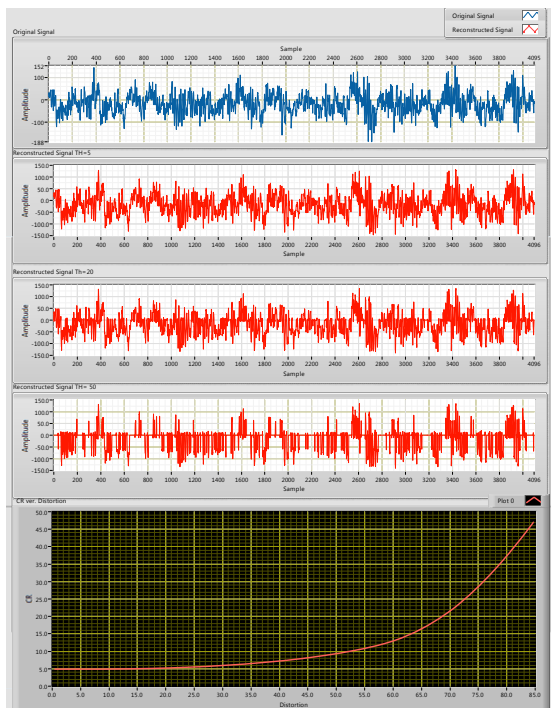

Fig. 4. Example of EEG data compression and reconstruction implementation.

implementation on both EEG and ECG data. In addition, applications of DWT data compression and reconstruction include other wireless sensor networks such as structure health monitoring (SHM) networks. However, we focus on WBSN, since EEG data is considered one of the largest data types. Note that the acceptable distortion rate depends on the characteristics of the application.

The rest of this paper is organized as follows. In Section II we present our system model. Basics of DWT is presented in II. In Section III, we describe our FPGA design and implementation. Results are then presented in Section IV. The paper is then concluded in Section V.

II. SYSTEM MODEL

Fig. 1 depicts a block diagram of typical WBSN architecture. The EEG data is collected from the patient through probes. The EEG signal is then passed through a low noise amplifier as well as a filter. The EEG signal is then passed through a parameter optimization block, which decides on the compression parameters such as filter length and appropriate compression ratio based on the selected application. EEG data is then compressed using any of the aforementioned techniques. The EEG data then gets quantized and transmitted through the wireless channel to the receiver, which estimates the quality of the channel and feed it back to the transmitter to adjust its compression ratio. In this paper, we focus on FPGA design and implementation of EEG data compression and reconstruction using DWT.

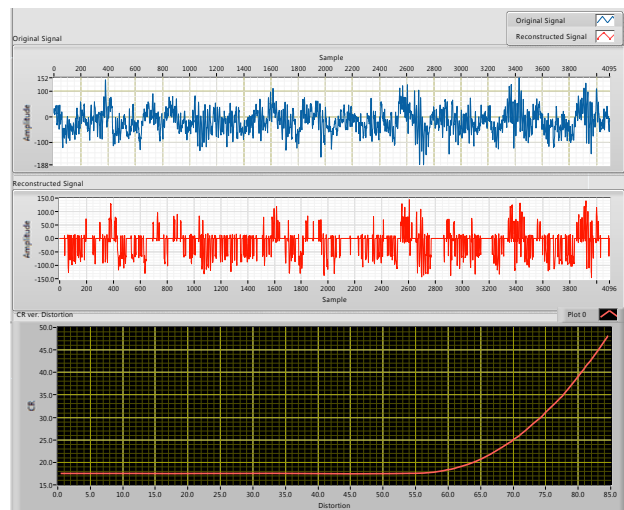

Fig. 5. DWT EEG data compression and reconstruction for filter length of 8 coefficients.

The wavelet series expansion for a given function $f(y)$ can be given by [13]:

$$f(y) = \sum_k c_{j_0}(k) \phi_{j_0,k}(y) + \sum_{j=j_0}^{\infty} \sum_k d_j(k) \Psi_{j,k}(y), \quad (1)$$

where c_{j_0} is the approximation coefficient, $\phi(y)$ is the scaling function used to provide an approximation of the function $f(y)$ at a scale j_0 , where j_0 is an arbitrary scale, $d_j(k)$ are the coefficients responsible for the coarse resolution and $\Psi(y)$ represents the wavelet function. Note that c_{j_0} can be calculated through

$$c_{j_0}(k) = \langle f(y), \phi_{j_0,k}(y) \rangle, \quad (2)$$

where $\langle \dots \rangle$ denote the inner product operation. Furthermore, $\Psi(y)$ is used to estimate the resolution coefficients according to

$$d_j(k) = \langle f(y), \Psi_{j,k}(y) \rangle. \quad (3)$$

DWT implements (2) and (3) through a tree of low and high pass filters.

TABLE I
FPGA RESOURCE UTILIZATION

Device Utilization	Used	Total	Percent
Slice register	16145	35200	45.9
Slice LUT	13896	17600	79
Block RAMS	18	60	30
DSP48s	16	80	20

III. FPGA DESIGN

We implement a complete DWT compression and reconstruction on FPGA based platform for real-time EEG data compression. We implement our design on National Instrument NI myRIO-1900 platform. It consists mainly of Xilinx

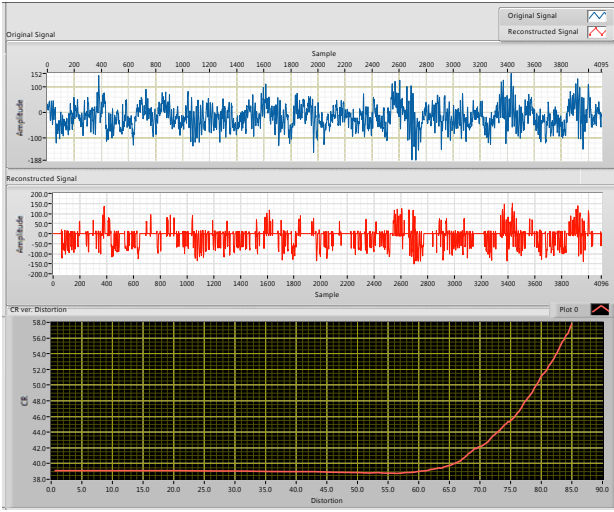

Fig. 6. DWT EEG data compression and reconstruction for filter length of 16 coefficients.

FPGA and Dual-core ARM Cortex-A9 processor as well as reconfigurable 8 analog inputs, 4 analog outputs, 32 digital I/O lines. The DWT is designed and tested first on Labview before it is downloaded and compiled on the FPGA for standalone operation.

Fig. 3 shows the complete Labview FPGA design of the DWT EEG data compression. The FPGA design consists of low pass filter block, high pass filter block and first input first output (FIFO) block. The EEG data is first passed through FIFO to read and buffer the data to the FPGA. The EEG data is convolved with both low pass and high pass filters simultaneously. The outputs of the two filters are combined in an alternating way where a sample from the low pass filter is followed by the following sample from the high pass filter output, i.e., a decimation of factor 2 as shown in Fig. 2. The resulted signal is then passed through the thresholding step. In this step, if the sample does not exceed the threshold, it is replaced by a zero. In other words, the threshold level controls the compression ratio. The resulted signal is the DWT output compressed signal.

The compression ratio is evaluated as:

$$C_R = \left(1 - \frac{M}{N}\right) \times 100, \quad (4)$$

where N is the length of the original signal and M is the number of non-zero samples generated after DWT thresholding. The distortion calculated through the root mean square difference of the reconstructed EEG data according to:

$$D = \frac{\|y - y_r\|}{\|y\|} \times 100, \quad (5)$$

where y is the original signal and y_r is the reconstructed signal.

IV. EXPERIMENTAL RESULTS

In the following we apply DWT compression on both EEG and ECG data types. We study the effect of different filter

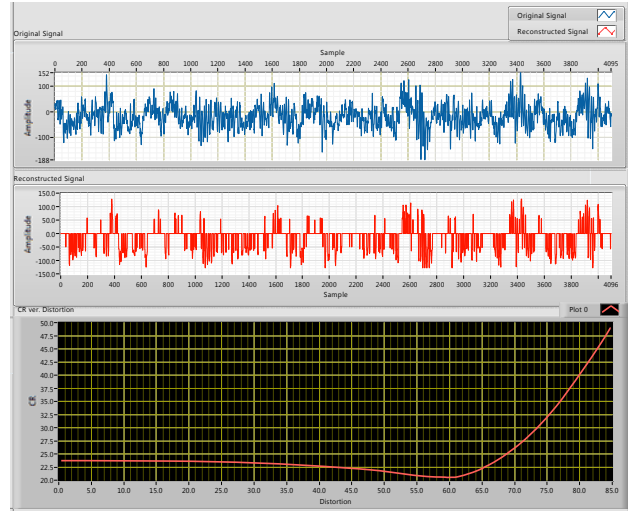

Fig. 7. DWT EEG data compression and reconstruction.

length on distortion ratio. In addition, apply different types of DWT on EEG data.

A. EEG data compression and reconstruction

Fig. 4 shows an inputted original EEG signal (top), three versions of the reconstructed signal at different threshold levels and the threshold to distortion ratio curve. As the threshold level increases, the EEG signal becomes more sparse resulting in less required transmitter power. In other words, the threshold represents the compression ratio. The tradeoff is that as threshold increases, more distortion occurs to the EEG signal, but the more compressed the data and the less required power to transmit it.

Table I presents a complete list of all the utilized resources of the FPGA used to implement the DWT compression such as look up tables (LUTs) and block random access memory (RAMs). The resources in Table 1 were estimated using Labview's FPGA toolbox compilation result. DWT requires a large number of LUTs throughout implementation. This indicates that a memory with an appropriate size should be dedicated in future commercialization of such compression technique.

In Figs. 5 and 6, we present the effect of different filter lengths on the performance of DWT data compression and reconstruction. We change the filter length from 8 (Fig. 5) to 16 (Fig. 6) coefficients. The lower the number of filter coefficients the better the compression and reconstruction process as seen from the compression ratio to distortion ratio curve.

B. Different DWT types

There exists several ways in which DWT is applied. In the previous figures, we used db02 DWT. In Fig. 7, we evaluate the performance of compression and reconstruction when used Haar DWT. Based on the application and type of signal, different DWT types should be used.

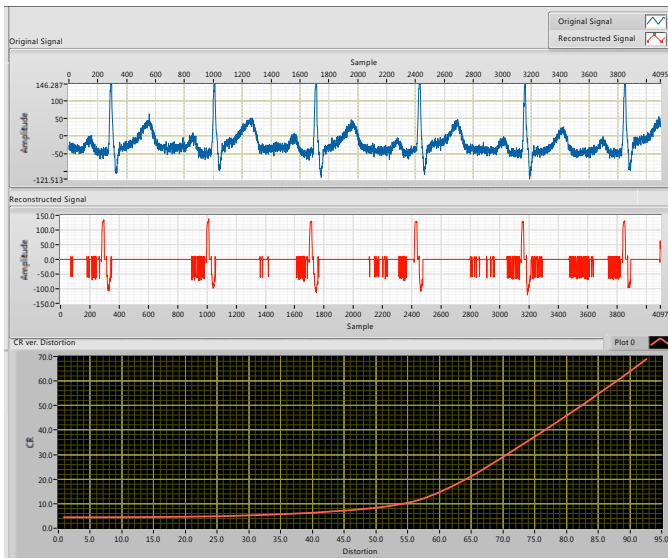

Fig. 8. Example of ECG data compression and reconstruction implementation.

C. ECG data compression and reconstruction

In Fig. 8, we show an example of applying our DWT FPGA implementation on ECG data. The ECG data is collected from [14]. The original ECG signal (top) is passed through the DWT compression before it gets reconstructed (middle). This shows that DWT compression and reconstruction can be applied on any generic data type.

V. CONCLUSION

We presented the design of a complete hardware model based on DWT data compression algorithm on FPGA based platform. We have presented the detailed low/high pass filter design and the hardware design blocks to realize the DWT transform, including, decimation and convolution design blocks. We used real EEG and ECG collected data. We showed that our design works for different filter lengths and different compression ratios. In addition, we presented a complete list of the resource blocks used by the FPGA to implement the design. We show that the performance of the compression and reconstruction model measured through distortion and compression ratio is heavily dependent on the DWT filter coefficient, type and threshold used. Hence, such parameters have to be tuned for desirable application performance, design complexity, and energy consumption.

ACKNOWLEDGMENT

This research was made possible by NPRP 6-150-2-059 and NPRP 7-684-1-127 grants from the Qatar National Research Fund (a member of The Qatar Foundation). The statements made herein are solely the responsibility of the authors.

REFERENCES

[1] A. J. Casson, D. C. Yates, S. J. M. Smith, J. S. Duncan, and E. Rodriguez-Villegas, "Wearable electroencephalography," *IEEE Engineering in Medicine and Biology Magazine*, vol. 29, no. 3, pp. 44–56, May 2010.

[2] H. Mamaghanian, N. Khaled, D. Atienza, and P. Vanderghyest, "Compressed sensing for real-time energy-efficient eeg compression on wireless body sensor nodes," *IEEE Transactions on Biomedical Engineering*, vol. 58, no. 9, pp. 2456–2466, Sept 2011.

[3] A. M. Abdulghani, A. J. Casson, and E. Rodriguez-Villegas, "Quantifying the performance of compressive sensing on scalp eeg signals," in *2010 3rd International Symposium on Applied Sciences in Biomedical and Communication Technologies (ISABEL 2010)*, Nov 2010, pp. 1–5.

[4] —, "Compressive sensing scalp eeg signals: implementations and practical performance," *Medical & Biological Engineering & Computing*, vol. 50, no. 11, pp. 1137–1145, 2012. [Online]. Available: <http://dx.doi.org/10.1007/s11517-011-0832-1>

[5] G. D. Poian, R. Bernardini, and R. Rinaldo, "Separation and analysis of fetal-ecg signals from compressed sensed abdominal eeg recordings," *IEEE Transactions on Biomedical Engineering*, vol. 63, no. 6, pp. 1269–1279, June 2016.

[6] D. Craven, B. McGinley, L. Kilmartin, M. Glavin, and E. Jones, "Compressed sensing for bioelectric signals: A review," *IEEE Journal of Biomedical and Health Informatics*, vol. 19, no. 2, pp. 529–540, March 2015.

[7] K. C. Yi, M. Sun, C. C. Li, and R. J. Scلابassi, "A lossless compression algorithm for multichannel eeg," in *[Engineering in Medicine and Biology, 1999. 21st Annual Conference and the 1999 Annual Fall Meeting of the Biomedical Engineering Society] BMES/EMBS Conference, 1999. Proceedings of the First Joint*, vol. 1, 1999, pp. 429 vol.1–.

[8] J. L. Crdenas-Barrera, J. V. Lorenzo-Ginori, and E. Rodriguez-Valdivia, "A wavelet-packets based algorithm for eeg signal compression," *Medical Informatics and the Internet in Medicine*, vol. 29, no. 1, pp. 15–27, 2004. [Online]. Available: <http://dx.doi.org/10.1080/14639230310001636499>

[9] P. de A Berger, F. A. de O Nascimento, J. C. do Carmo, and A. F. da Rocha, "Compression of emg signals with wavelet transform and artificial neural networks," *Physiological Measurement*, vol. 27, no. 6, p. 457, 2006. [Online]. Available: <http://stacks.iop.org/0967-3334/27/i=6/a=003>

[10] H. Daou and F. Labeau, "Dynamic dictionary for combined eeg compression and seizure detection," *IEEE Journal of Biomedical and Health Informatics*, vol. 18, no. 1, pp. 247–256, Jan 2014.

[11] G. Xu, J. Han, Y. Zou, and X. Zeng, "A 1.5-d multi-channel eeg compression algorithm based on nlspiht," *IEEE Signal Processing Letters*, vol. 22, no. 8, pp. 1118–1122, Aug 2015.

[12] R. G. Andrzejak, K. Lehnertz, F. Mormann, C. Rieke, P. David, and C. E. Elger, "Indications of nonlinear deterministic and finite-dimensional structures in time series of brain electrical activity: Dependence on recording region and brain state," *Phys. Rev. E*, vol. 64, p. 061907, Nov 2001. [Online]. Available: <http://link.aps.org/doi/10.1103/PhysRevE.64.061907>

[13] S. Mallat, *A Wavelet Tour of Signal Processing, Third Edition: The Sparse Way*, 3rd ed. Academic Press, 2008.

[14] P. Net. (2015, Aug.) Fantasia database subset. [Online]. Available: <https://physionet.org/physiobank/database/fantasia/subset/>