

A Simple Angle of Arrival Estimation System

Original

A Simple Angle of Arrival Estimation System / Badawy, A.M.H.B.M., Khattab, T., Trinchero, D., Elfouly, T., Mohamed, A..
- STAMPA. - (2017). (2017 IEEE Wireless Communications and Networking Conference (WCNC)).

Availability:

This version is available at: 11583/2664158 since: 2017-01-30T12:34:45Z

Publisher:

IEEE

Published

DOI:

Terms of use:

This article is made available under terms and conditions as specified in the corresponding bibliographic description in the repository

Publisher copyright

IEEE postprint/Author's Accepted Manuscript

©2017 IEEE. Personal use of this material is permitted. Permission from IEEE must be obtained for all other uses, in any current or future media, including reprinting/republishing this material for advertising or promotional purposes, creating new collecting works, for resale or lists, or reuse of any copyrighted component of this work in other works.

(Article begins on next page)

A Simple Angle of Arrival Estimation System

Ahmed Badawy^{*‡}, Tamer Khattab[†], Daniele Trinchero^{*}, Tarek ElFouly[‡], and Amr Mohamed[‡],

^{*}Politecnico di Torino, DET (ahmed.badawy,daniele.trinchero@polito.it)

[†]Qatar University, Electrical Engineering Dept. (tkhattab@qu.edu.qa)

[‡]Qatar University, Computer Engineering Dept. (tarekfouly,amrm@qu.edu.qa)

Abstract—We propose a practical, simple and hardware friendly, yet novel and very efficient, angle of arrival (AoA) estimation system. Our intuitive, two-phases cross-correlation based system requires a switched beam antenna array with a single radio frequency chain. Our system cross correlates a reference omni-directional signal with a set of received directed signals to determine the AoA. Practicality and high efficiency of our system are demonstrated through performance and complexity comparisons with multiple signal classification algorithm.

Index Terms—Angle of arrival estimation, AoA, Switched beam.

I. INTRODUCTION

Angle of arrival (AoA) estimation is a process that determines the direction of arrival of a received signal by processing the signal impinging on an antenna array. Estimating the AoA is a crucial step in many military and civilian applications, particularly related to security. Applications of estimating the AoA include beamforming, tracking [1], localization and physical layer secrecy [2].

The subject of AoA has been extensively studied in the literature [3], [4], [5], [6], [7]. From a system perspective, one can categorize AoA estimation systems into two main categories [3]: (i) **Switched beam system (SBS)** which uses a fixed number of beams to scan the azimuth plane. The AoA is the angle of the beam with the highest received signal strength (RSS). SBS is easy to implement since it requires a single receiver radio frequency (RF) chain and no baseband signal processing, however, it fails at low signal to noise ratio (SNR) levels, and (ii) **Adaptive array system (AAS)** which can steer the beam in any desired direction using baseband signal processing. AAS requires M receiver RF chains to estimate the AoA using baseband processing, where M is the number of antennas. AAS can operate at SNRs lower than SBS, but has higher hardware and computational complexities.

AoA estimation using AAS can be divided into two main techniques: (1) **Classical AoA techniques** based on one of two main methods: *Delay and Sum*, also known as *Bartlett* [8] and *Minimum Variance Distortionless Response (MVDR)*, also known as *Capon* [9]. In Bartlett, the AoA is estimated by steering the beams electronically and estimating the power spectrum of the received signal looking for the angle(s) corresponding to peak(s) in the spatial power spectrum. The main drawback of the Bartlett technique is that signal impinging with angular separation less than $2\pi/M$ can not be resolved. The Capon technique relatively solves the angular resolution drawback of the Bartlett method at the cost of more baseband

processing to perform matrix inversion [9], and (2) **Subspace techniques** based on the concept of orthogonality of signal subspace to noise subspace. The most widely investigated method in this group is multiple signal classification (MUSIC) [10], [11]. MUSIC provides high angular resolution while operating at low SNR levels. This comes at the cost of requiring full a priori knowledge of the number of sources and the array response, whether measured and stored or computed analytically [12]. The signal and noise subspaces are distinguished through an eigen decomposition operation on the covariance matrix of the received signal. This operation requires a substantial computational complexity.

Due to its attractive simplicity, several attempts have been performed to integrate SBS with other theories to estimate the AoA as presented in [13]. Their methodology is based on neural network, in which the AoA problem is transferred into a mapping problem. This requires a priori knowledge of the number of sources as well as the multiple access scheme adopted between them. It is also assumed that a power control scheme is implemented such that the source powers are equal. Such requirements and assumptions limit the deployment of the system to very few scenarios. Exploiting the power ratio between adjacent beams to estimate the AoA is presented in [14]. A table driven SBS system is presented in [15]. All of these variant techniques do not tackle the drawbacks of the conventional SBS, but rather make its implementation easier. In [16], [17] exploit sectorized antennas along to improve the performance of SBS.

Our contributions in this work as compared to available literature are as follows: We propose a new low complexity and hardware friendly AoA estimation system based on beam switching. We compare the proposed scheme with MUSIC algorithm (famous for being one of the best performing state-of-the-art for low SNR) and show that our proposed solution have a very comparable performance. We also compare the computational complexity of our approach with the existing ones and conclude that our approach has a significant lower hardware and computational complexities. To the best of the authors' knowledge, the proposed technique based on using the cross correlation coefficient between a collected reference omni-directional signal and a scanned directed beam signal to estimate the AoA has not been presented in the literature before.

The notation throughout the paper is chosen as: small letters to represent single samples, small bold letters to represent vectors and capital bold letters to represent matrices.

The rest of this paper is organized as follows: In Section II our system model is presented. A review of MUSIC algorithm is presented in Section III. We then propose our two-phase cross correlation based AoA estimation system in Section IV. Practical aspects of our system are addressed in Section V. The performance of our proposed system is evaluated in Section VI. Analysis of the complexity of our AoA estimation method is provided in Section VII. The paper is concluded in section VIII.

II. SYSTEM MODEL

Let us assume a source that transmits a signal $s(t)$ and a receiver equipped with an SBS consisting of M antenna elements separated by a fixed separation d and operating at frequency f (Fig. 1).

$$\mathbf{a}(\phi_k) = [w_{k1}, w_{k2}, \dots, w_{kM}], \quad (1)$$

where ϕ is the azimuth angle, \mathbb{C} is the set of complex numbers and w_{km} for $m \in [1 : M]$ are the weights applied across the antenna array elements such that the steering vector $\mathbf{a}(\phi)$ is pointing to an azimuth angle ϕ_k . The received and sampled signal, $x[n]$, in the vector notation for the k^{th} beam, \mathbf{x}_k , is

$$\mathbf{x}_k = \mathbf{a}(\phi_k)\mathbf{S} + \mathbf{v}, \quad (2)$$

where \mathbf{x}_k (with dimensions $1 \times N$) is the signal received from the k^{th} beam (beam pointing at angle ϕ_k) for $k \in [1 : K]$, K is the total number of generated beams, N is the total number of collected samples, \mathbf{S} is the sampled version of the transmitted signal (with dimensions $M \times N$) as seen by the M elements of the antenna array and \mathbf{v} is the additive white Gaussian noise (AWGN) (with dimensions $1 \times N$).

The weights are updated to change ϕ_k in order to scan the angular space of interest. The steering vectors, $\mathbf{a}(\phi)$, for linear, circular or planar array formations can be calculated analytically. It is worth noting that once the steering vector is set, the operation of our proposed system is independent of the antenna array formation. For a uniform linear array (ULA) with uniform excitation, $\mathbf{a}(\phi)$ is given by [3]:

$$\mathbf{a}(\phi) = [1, e^{j\beta d \cos(\phi)}, e^{j\beta 2d \cos(\phi)}, \dots, e^{j\beta(M-1)d \cos(\phi)}], \quad (3)$$

where $\beta = \frac{2\pi}{\lambda}$ is the wave number, λ is the wavelength and ϕ ranges between $[0 : \pi]$. For a uniform circular array (UCA), $\mathbf{a}(\phi)$, is given by [3]:

$$\mathbf{a}(\phi) = [e^{j\beta r \cos(\phi - \phi_1)}, e^{j\beta r \cos(\phi - \phi_2)}, \dots, e^{j\beta r \cos(\phi - \phi_M)}], \quad (4)$$

where $\phi_m = 2\pi m/M$, $m \in [1 : M]$, ϕ ranges between $[0 : 2\pi]$ and r is the radius of the antenna array. The elevation angle is assumed to be 90 degrees in 1-D AoA estimation techniques. For a linear array of M elements with uniform excitation, the total number of orthogonal beams that can be generated is M , i.e., $K = M$. However, using non-uniform excitation such as Dolph-Chebyshev or Taylor [18], it is possible to generate more orthogonal beams for the same number of antenna elements, M , i.e., $K > M$, as will be discussed later.

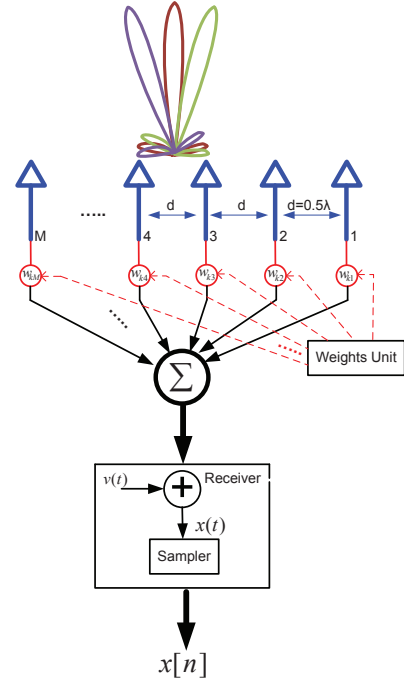

Fig. 1: Proposed cross correlation switched beam system for M antenna elements.

We assume that the our scanning time is much less than the the time it takes the transmitter to move from one location to the next. In addition, we assume that the transmitter continues to transmit highly correlated signal during our scanning time. This can be safely assumed since the scanning time should not exceed few milliseconds.

III. REVIEW OF MUSIC ALGORITHM

Since we compare our results to the MUSIC algorithm, a brief derivation follows for completeness. The MUSIC algorithm operates on the autocovariance function of the received signal matrix \mathbf{X} , with dimensions $M \times N$, which is denoted by \mathbf{R}_{XX} . After an eigenvalue decomposition (EVD) on \mathbf{R}_{XX} , it can be written as

$$\begin{aligned} \mathbf{R}_{XX} &= \mathbf{a}(\phi)\mathbf{R}_{SS}\mathbf{a}^H(\phi) + \sigma^2\mathbf{I} \\ &= \mathbf{U}_S\mathbf{\Lambda}_S\mathbf{U}_S^H + \mathbf{U}_V\mathbf{\Lambda}_V\mathbf{U}_V^H, \end{aligned} \quad (5)$$

where \mathbf{R}_{SS} is the autocovariance matrix of the transmitted signal, σ^2 is the noise variance, $(\cdot)^H$ denotes the hermitian operation, \mathbf{I} is the $M \times M$ unitary matrix, \mathbf{U}_S and \mathbf{U}_V are the signal and noise subspaces unitary matrices and $\mathbf{\Lambda}_S$ and $\mathbf{\Lambda}_V$ are diagonal matrices of the eigenvalues of the signal and noise. The spatial power spectrum for the MUSIC technique is given by [10], [19]:

$$P_{\text{MUSIC}}(\phi) = \frac{1}{\mathbf{a}^H(\phi)\mathbf{P}_V\mathbf{a}(\phi)}, \quad (6)$$

where $\mathbf{P}_V = \mathbf{U}_V\mathbf{U}_V^H$. For MUSIC, number of sources is a prerequisite. If the number of sources is not known a priori, it should be estimated prior to AoA estimation and fed to MUSIC.

IV. PROPOSED CROSS-CORRELATION SWITCHED BEAM SYSTEM (XSBS)

The existing high performance AoA estimation techniques either have a low resolution problem or require extensive computational complexity to estimate the AoA. Moreover, they require M receivers to implement the AoA estimation technique which increases the hardware complexity tremendously. On the other hand, although conventional SBSs have low hardware and computational complexities, they fail to operate at medium and low SNR levels.

We propose a novel cross-correlation based SBS (XSBS) AoA estimation technique. Our XSBS benefits from the low hardware complexity of the conventional SBS, which requires a single receiver, yet does not sacrifice the resolution or performance at medium and low SNR levels. Moreover, our XSBS requires low computational complexity to estimate the AoA since it is based on estimating the cross correlation between two collected one dimensional vector of samples. With such low hardware and computational complexity, our XSBS will consume less power which will be very beneficial, particularly, if implemented on a portable device. Furthermore, XSBS requires neither prior information on the number of the sources nor the sources to be uncorrelated.

In the following, we provide a detailed description of the operation of our proposed XSBS alongside the corresponding basic mathematical modelling of the system.

A. XSBS Design

XSBS goes through two phases to estimate the AoA as follows.

- **Phase I:** the *Weights Unit* depicted in Fig. 1 controls the RF switches such that a single antenna element is turned on, while the remaining antenna elements are switched off. In the selected antenna element branch, the applied weight is unity gain and zero phase shift. Assuming approximate omni-directional pattern for individual antenna elements, XSBS then acquires N samples to collect the signal \mathbf{x}_o .
- **Phase II:** In this phase the omni-directional signal collected in the first phase, i.e., \mathbf{x}_o , becomes our reference signal. The *Weights Unit* sends the sets of weights $\mathbf{a}(\phi_k)$, for $k \in [1 : K]$. The set $\mathbf{a}(\phi_k)$ steers the main beam of the antenna array to the direction ϕ_k . XSBS then acquires N samples to collect the signal \mathbf{x}_k . A cross correlation operation between our reference signal \mathbf{x}_o and the k^{th} beam signal is applied. The cross correlation coefficient (R_{ko}) is calculated for K beams. The AoA is the index $\hat{\phi}_k$ with the highest R_{ko} .

B. Cross Correlation Estimation

In the second phase of estimating the AoA, XSBS cross correlates the omni-directional reference signal, $\mathbf{x}_o = [x_o[1], \dots, x_o[n], \dots, x_o[N]]$, with the directed beam signals, $\mathbf{x}_k = [x_k[1], \dots, x_k[n], \dots, x_k[N]]$, for $k \in [1 : K]$ through

the region of interest as in (2). The cross correlation coefficient between the reference signal and the k^{th} signal is given by

$$R_{ko} = \frac{1}{N} (\mathbf{x}_k \mathbf{x}_o^H). \quad (7)$$

The cross correlation between the omni-directional reference signal and the signals received from the switched beams is the highest at the true AoA and relatively negligible otherwise. To show that, we provide the derivation below. The received signal from the k^{th} beam if k is the true AoA is

$$x_k^{Tr}[n] = G_k s[n + \tau] + v[n + \tau], \quad (8)$$

where G_k is the directive antenna array gain and τ is a random time shift. The received signal from the k^{th} beam if k is not the true AoA is $x_k^F[n] = v[n + \tau]$. The cross correlation function in the case of the true AoA, R_{ko}^{Tr} , can be written as

$$\begin{aligned} R_{ko}^{Tr} &= \frac{1}{N} \sum_{n=1}^N x_k^{Tr}[n] x_o^H[n] \\ &= \frac{1}{N} \sum_{n=1}^N \left[(G_k s[n + \tau] + v[n + \tau]) \right. \\ &\quad \left. (G_o s^H[n] + v^H[n]) \right] \\ &= \frac{G_o G_k}{N} \sum_{n=1}^N s[n + \tau] s^H[n] + \frac{G_k}{N} \sum_{n=1}^N s[n + \tau] v^H[n] \\ &\quad + \frac{G_o}{N} \sum_{n=1}^N v[n + \tau] s^H[n] + \frac{1}{N} \sum_{n=1}^N v[n + \tau] v^H[n]. \end{aligned} \quad (9)$$

The cross correlation function in the case that k is not the true AoA, R_{ko}^F , can be written as

$$\begin{aligned} R_{ko}^F &= \frac{1}{N} \sum_{n=1}^N x_k^F[n] x_o^H[n] \\ &= \frac{1}{N} \sum_{n=1}^N (v[n + \tau]) (G_o s^H[n] + v^H[n]) \\ &= \frac{G_o}{N} \sum_{n=1}^N v[n + \tau] s^H[n] + \frac{1}{N} \sum_{n=1}^N v[n + \tau] v^H[n]. \end{aligned} \quad (10)$$

With R_{ss} being the autocorrelation function of $s[n]$, R_{sv} the cross correlation between $s[n]$ and $v[n]$, and $s[n]$ and $v[n]$ are stationary processes, (9) can be written as

$$R_{ko}^{Tr} = G_o G_k R_{ss}[\tau] + G_k R_{sv}[\tau] + G_o R_{vs}[\tau] + \sigma^2, \quad (11)$$

where σ^2 is the noise variance. (10) can be written as

$$R_{ko}^F = G_o R_{vs}[\tau] + \sigma^2. \quad (12)$$

Since $s(t)$ and $v(t)$ are uncorrelated, R_{sv} and R_{vs} can be considered negligible. Consequently, (11) and (12) reduce to:

$$R_{ko}^{Tr} = G_o G_k R_{ss}[\tau] + \sigma^2, \quad (13)$$

$$R_{ko}^F = \sigma^2. \quad (14)$$

From (13) and (14), one can see that $R_{ko}^{Tr} > R_{ko}^F$. As the transmitted power increases, $R_{ko}^{Tr} \gg R_{ko}^F$.

V. ADDRESSING PRACTICAL ASPECTS

In this section, we address some practical aspects of our proposed XSBS. We start by presenting a schematic of XSBS, which details the required components needed to implement XSBS. Then, we proceed to discuss incorporating non-uniform excitation in order to increase the total number of orthogonal generated beams.

A. Number of generated orthogonal beams

Orthogonal beams indicate that the peak of the current beam is located at a minima of the two adjacent beams. Hence, when collecting a signal from one beam (assuming a signal is impinging from the direction of the peak), no signal is leaked from its adjacent ones. M is a key factor in determining the resolution of our XSBS. The higher the number of antenna elements, the smaller the half power beam width (HPBW) of the antenna array beam. Hence, our AoA location grid (assuming orthogonal beams) can become finer and finer, i.e., covering more and more locations as required. A smaller HPBW leads to a better resolution. It is possible to generate as many non-orthogonal beams as possible. For example, for ULA, it is possible to generate 180 beams. However, this approach will increase the scanning time significantly. When using orthogonal beams, the signal impinging on directions that are not the peak location, will be detected by two adjacent beams with different powers. On the contrary, a higher M will increase the hardware complexity of XSBS since they will require more weight adjustment components.

Using a non-uniform excitation such as Dolph-Chebyshev excitation, it is possible to generate more *orthogonal* beams using the same M antenna elements. In this case, for ULA, the array response vector $\mathbf{a}(\phi)$ is defined by the Chebyshev polynomial of degree $M-1$, $T_{M-1}(y)$, in the scaled variable y as [18]:

$$\mathbf{a}(\phi) = T_{M-1}(y), \quad y = y_0 \cos\left(\frac{\beta d \cos(\phi)}{2}\right). \quad (15)$$

The scale factor, y_0 , is estimated as $y_0 = \cosh\left(\frac{\cosh^{-1}(R)}{M-1}\right)$, where $\cosh^{-1}(\cdot)$ is the inverse hyperbolic cosine function, R is the main lobe to side lobe ratio. The elements of the weight vector $\mathbf{a}(\phi_k)$ for a fixed k and $m \in [1 : M]$ can be calculated by creating the z-transform of the array response factor from its zeros and then applying an inverse z-transform. The $M-1$ zeros of $T_{M-1}(y)$ are [18]:

$$y_i = \cos\left(\frac{(i-1/2)\pi}{M-1}\right), \quad \text{for } i = 1, 2, \dots, M-1. \quad (16)$$

Let $\psi = \beta d \cos(\phi)$, the pattern zeros are [18]:

$$\psi_i = 2 \cos^{-1}\left(\frac{y_i}{y_0}\right), \quad Z_i = 2 \exp[j\psi_i], \quad (17)$$

where $\cos^{-1}(\cdot)$ is the inverse cosine function, $j = \sqrt{-1}$. The z-transform of the array factor, $A(Z)$, is then [18]:

$$A(Z) = Z^{-(M-1)/2} \prod_{i=1}^{M-1} (Z - Z_i). \quad (18)$$

The coefficients, \mathbf{a}_c of dimension $1 \times M$, of the inverse z-transform of $A(Z)$ are the weight vector, which is steered towards ϕ_k to generate $\mathbf{a}(\phi_k)$ by $\psi_k = \beta d \cos \phi_k$, then $\mathbf{a}(\phi_k) = \mathbf{a}_c \exp[j * \psi_k]$.

VI. PERFORMANCE EVALUATION

First we present results for XSBS's angular resolution. XSBS AoA estimation performance is then compared to MUSIC in terms of peak to floor ratio (PFR), root mean square error (RMSE) and 3-dB success rate for single transmitter case.

A. XSBS practical aspects

We start by analyzing the resolution of XSBS; we plot the steered antenna array beam for $M = 17$, separation $d = 0.5\lambda$, $R = 15$ dB, with Dolph-Chebyshev non-uniform excitation in Fig. 2. The achieved HPBW is approximately 6 degrees with a total of $K = 32$ *orthogonal* beams scanning the 180 degrees¹. As M increases, the resolution of XSBS improves since the HPBW decreases.

B. XSBS AoA Estimation

In the following we evaluate the performance of XSBS AoA estimation with respect to different aspects. We present the PFR as an intuition that XSBS can correctly estimate the true AoA. We compare RMSE and 3-dB success rate of XSBS. We show how XSBS performs when two sources are impinging on the antenna array. The simulation settings in the subsequent figures is as follows. We simulate XSBS with linear antenna array with Dolph-Chebyshev excitation using $M = 17$. MUSIC uses uniform linear antenna array with $M = 16$. We plot the normalized cross correlation coefficient (7) to represent the spatial power, versus the azimuth angle ϕ .

¹Fig. 2 is plotted using the MATLAB toolbox of [18].

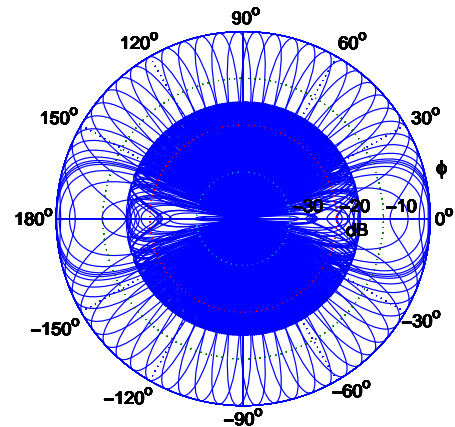

Fig. 2: Beam switching antenna array for $M = 17$ with Dolph-Chebyshev excitation, $R = 15$ dB and $d = 0.5\lambda$ with a total of 32 orthogonal beams with HBPW = 6 degrees.

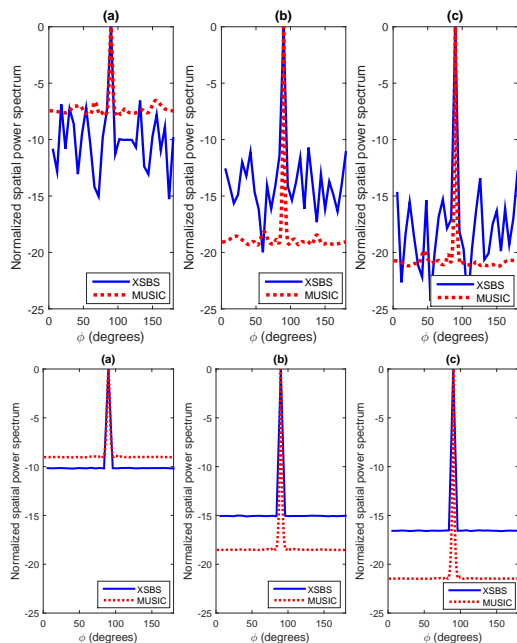

Fig. 3: PFR for XSBS vs. MUSIC for single run (top) and average of 1000 iterations (bottom) at SNR = -10 dB for different number of samples (a) $N = 100$, (b) $N = 1000$ and (c) $N = 2000$ samples.

We assume strong line of sight with block fading (i.e channel is almost constant during the whole processing time). The type of signal we use is modulated quadrature amplitude (QAM). The reference of the incident azimuth angle is the plane containing the linear antenna array.

As we stated in the System Model, we can safely assume that the transmitter continues to transmit a highly coherent signal during the scanning time of XSBS. For example, for a number of beams $K = 32$ and if we collect $N = 1000$ samples from each direction and for a sampling frequency of 5 MHz, the total scanning time is 6.4 milliseconds. Moreover, we proposed binary search approach that reduces the number of required scans from K to $\log_2 k$. For the provided example, the number of scans reduces to 5, which reduces our scanning time to 1 millisecond. For a sampling frequency of 20 MHz, the scanning time is further reduced to the quarter, i.e., 250 and 25 microsecond for $N = 1000$ and 100 samples, respectively.

1) *Peak to floor ratio*: In Fig. 3, we simulate XSBS and MUSIC at SNR = -10 dB for $N = 100, 1000$ and 2000 samples for a signal with arriving angle $\phi_k = 90^\circ$ for a single run (top) and an average of 1000 iteration (bottom). It is shown that XSBS can accurately determine the correct AoA by having the highest peak at the location of the incident angle. Increasing the number of samples improves the performance of XSBS. XSBS achieves PFR = 8 dB, 15 dB and 17 dB for $N = 100, 1000$ and 2000 samples, respectively. MUSIC has a higher PFR achieving PFR = 10 dB, 18 dB and 22 dB for $N = 100, 1000$ and 2000 samples, respectively.

2) *Performance for a single transmitter*: Fig. 4 depicts the RMSE of XSBS and MUSIC versus SNR (in steps of 2 dB) for different number of samples. XSBS achieves a comparable RMSE to MUSIC with approximately 2 dB performance gap in favor of MUSIC. For example, for $N = 1000$ samples XSBS requires SNR > -16 dB to achieve RMSE of approximately zero, while MUSIC requires SNR > -18.

VII. COMPLEXITY COMPARISON

Complexity analysis provides a qualitative measure of system power consumption as well as real-time processing abilities both on software and hardware subsystems which are critical in dynamic environment such as battlefield.

For MUSIC, there are three major computational steps needed to estimate the AoA. The first one is the autocovariance function, which requires multiplication of two matrices with sizes $M \times N$ and $N \times M$. The exact number of floating-point operations (flops) needed for this matrix multiplication is $M^2(2N - 1)$. The complexity of the first step is $\mathcal{O}(M^2N)$. The second step is the EVD operation, which has a complexity of $\mathcal{O}(M^3)$ [20]. The third step is obtaining the spatial pseudo-spectrum, which has a complexity of $\mathcal{O}(JM)$ [19], with J being the number of spectral points of the total angular field of view. Therefore, the complexity of MUSIC is given by $\mathcal{O}(M^2N + M^3 + JM)$. In [20], the complexity of MUSIC is given by $\mathcal{O}(M^2N + M^2P)$, with P being the number of potential AoAs. In [21], the EVD is simplified using the fast decomposition technique [22], which reduces the complexity of MUSIC to $\mathcal{O}(M^2P + M(M - P)J + (M - P)J)$.

For XSBS, (7) is applied on two vectors each has a dimension of $1 \times N$. The vector multiplication in (7) for each $k \in [1 : K]$ requires N multiplications and $N - 1$ additions. Therefore, for K beams, the exact number of flops is $K(2N - 1)$. Hence, the complexity of XSBS is $\mathcal{O}(KN)$. For non uniform excitation, $K \approx 2M$, which reduces the complexity to $\mathcal{O}(MN)$. Consequently, the computational complexity

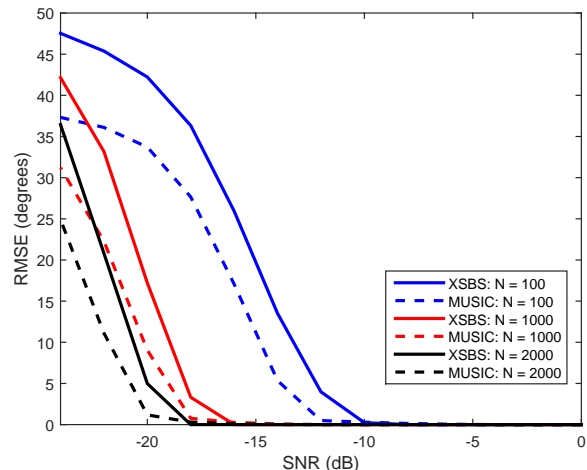

Fig. 4: RMSE of XSBS and MUSIC vs. SNR for different number of samples for single transmitter.

TABLE I: Comparison between MUSIC and XSBS

Item	MUSIC	XSBS
Number of receivers	M	1
EVD	Yes	No
Number of sources	Must be known a priori	Not needed
Correlation between sources	Must be uncorrelated	Works for both correlated and uncorrelated
Maximum number of sources	$M - 1$	K
Computational Complexity	$\mathcal{O}(M^2N + M^3 + JM)$	$\mathcal{O}(MN)$

of XSBS is considerably less than the complexity needed in the first step of MUSIC only. In Table I, we present a comparison between XSBS AoA estimation and MUSIC in terms of different criteria. It is clear that XSBS has lower hardware and computational complexities and less stringent requirements than MUSIC.

VIII. CONCLUSION

In this paper, we proposed a hardware friendly AoA estimation system. Our system first collects an omni-directional signal to be used as a reference signal. The system then switches the main beam to scan the angular region of interest. The collected signals from the switched beams are cross correlated with the reference signal. The cross correlation coefficient is the highest at the true AoA and relatively negligible otherwise. Our algorithm can operate with any antenna array formation with known steering vector. We showed that our system has a comparable performance to MUSIC. The number of sources that can be detected using our system is limited by the number of switched beams, which is greater than or equal to the number of antenna elements. In addition, we showed that our system has significantly reduces both hardware and computational complexities.

ACKNOWLEDGMENT

This research was made possible by NPRP 5-559-2-227 grant from the Qatar National Research Fund (a member of The Qatar Foundation). The statements made herein are solely the responsibility of the authors.

REFERENCES

- [1] B. Liao, Z. Zhang, and S. Chan, "A new robust kalman filter-based subspace tracking algorithm in an impulsive noise environment," *Circuits and Systems II: Express Briefs, IEEE Transactions on*, vol. 57, no. 9, pp. 740–744, Sept 2010.
- [2] A. Badawy, T. Khattab, T. Elfouly, D. Mohamed, A. Trincherro, and C. Chiasserini, "Secret key generation based on aoa estimation for low snr conditions," in *Vehicular Technology Conference (VTC Spring), 2015 IEEE 81st*, May 2015, pp. 1–7.
- [3] T. E. Tuncer and B. Friedlander, *Classical and Modern Direction-of-Arrival Estimation*. Academic Press, 2009.
- [4] C. A. Balanis and P. I. Ioannides, "Introduction to smart antennas," *Synthesis Lectures on Antennas*, vol. 2, no. 1, pp. 1–175, 2007.
- [5] Z. Chen, G. Gokeda, and Y. Yu, *Introduction to Direction-of-Arrival Estimation*. Artech House, 2010.
- [6] S. Chandran, *Advances in Direction-of-Arrival Estimation*. Artech House, 2006.
- [7] J. Foutz, A. Spanias, and M. K. Banavar, *Narrowband Direction of Arrival Estimation for Antenna Arrays*. Morgan & Claypool Publishers, 2006.
- [8] M. S. BARTLETT, "Periodogram analysis and continuous spectra," *Biometrika*, vol. 37, no. 1-2, pp. 1–16, 1950. [Online]. Available: <http://biomet.oxfordjournals.org/content/37/1-2/1.short>
- [9] J. Capon, "High-resolution frequency-wavenumber spectrum analysis," *Proceedings of the IEEE*, vol. 57, no. 8, pp. 1408–1418, 1969.
- [10] R. O. Schmidt, "A signal subspace approach to multiple emitter location and spectral estimation," Ph.D. dissertation, Stanford University.
- [11] P. Stoica, P. Handel, and A. Nehoral, "Improved sequential music," *Aerospace and Electronic Systems, IEEE Transactions on*, vol. 31, no. 4, pp. 1230–1239, Oct 1995.
- [12] A. Weiss and B. Friedlander, "Doa and steering vector estimation using a partially calibrated array," *Aerospace and Electronic Systems, IEEE Transactions on*, vol. 32, no. 3, pp. 1047–1057, July 1996.
- [13] K. Gotsis, K. Siakavara, and J. Sahalos, "On the direction of arrival (doa) estimation for a switched-beam antenna system using neural networks," *Antennas and Propagation, IEEE Transactions on*, vol. 57, no. 5, pp. 1399–1411, May 2009.
- [14] Y. Ozaki, J. Ozawa, E. Taillefer, J. Cheng, and Y. Watanabe, "Direction-of-arrival estimation using adjacent pattern power ratio with switched beam antenna," in *Communications, Computers and Signal Processing, 2009. PacRim 2009. IEEE Pacific Rim Conference on*, Aug 2009, pp. 453–458.
- [15] J. Lee, D. Kim, C. K. Toh, T. Kwon, and Y. Choi, "A table-driven aoa estimation algorithm for switched-beam antennas in wireless networks," in *Wireless Conference 2005 - Next Generation Wireless and Mobile Communications and Services (European Wireless), 11th European*, April 2005, pp. 1–6.
- [16] J. Werner, J. Wang, A. Hakkarainen, N. Gulati, D. Patron, D. Pfeil, K. Dandekar, D. Cabric, and M. Valkama, "Sectorized antenna-based doa estimation and localization: Advanced algorithms and measurements," *IEEE Journal on Selected Areas in Communications*, vol. 33, no. 11, pp. 2272–2286, Nov 2015.
- [17] J. Werner, J. Wang, A. Hakkarainen, D. Cabric, and M. Valkama, "Performance and cramer-rao bounds for doa/rss estimation and transmitter localization using sectorized antennas," *IEEE Transactions on Vehicular Technology*, vol. 65, no. 5, pp. 3255–3270, May 2016.
- [18] S. J. Orfanidis, *Electromagnetic Waves and Antennas*, 2010.
- [19] A. Khallaayoun, "A High Resolution Direction of Arrival Estimation Analysis and Implementation in a Smart Antenna System," Ph.D. dissertation, Montana State University.
- [20] C. Stoeckle, J. Munir, A. Mezghani, and J. A. Nossek, "Doa estimation performance and computational complexity of subspace- and compressed sensing-based methods," in *WSA 2015; 19th International ITG Workshop on Smart Antennas; Proceedings of*, March 2015, pp. 1–6.
- [21] Y. Zhang and B. P. Ng, "Music-like doa estimation without estimating the number of sources," *Signal Processing, IEEE Transactions on*, vol. 58, no. 3, pp. 1668–1676, March 2010.
- [22] G. Xu and T. Kailath, "Fast subspace decomposition," *Signal Processing, IEEE Transactions on*, vol. 42, no. 3, pp. 539–551, Mar 1994.