

A model-based methodology for rapid designing of hydraulic breakers

*Original*

A model-based methodology for rapid designing of hydraulic breakers / Franco, Walter; Ferraresi, Carlo. - In: INTERNATIONAL JOURNAL OF FLUID POWER. - ISSN 1439-9776. - ELETTRONICO. - (2017), pp. 1-9. [10.1080/14399776.2016.1270704]

*Availability:*

This version is available at: 11583/2664065 since: 2017-01-27T16:28:10Z

*Publisher:*

TuTech Innovation GmbH

*Published*

DOI:10.1080/14399776.2016.1270704

*Terms of use:*

This article is made available under terms and conditions as specified in the corresponding bibliographic description in the repository

*Publisher copyright*

(Article begins on next page)

# **A model-based methodology for rapid designing of hydraulic breakers**

**Walter Franco\* and Carlo Ferraresi**

*Department of Mechanical and Aerospace Engineering, Politecnico di Torino  
C.so Duca degli Abruzzi 24, 10129 Torino, Italy*

\* Corresponding author *e-mail*: [walter.franco@polito.it](mailto:walter.franco@polito.it)

## **Abstract**

The design and dimensioning of a hydraulic breaker with nitrogen spring is often carried out on the base of tradition and empirical considerations. This article proposes a methodology dedicated to such breakers that, with a simplified procedure, allows a rapid determination of the main dimensions of piston and spring, starting from the required performance, namely the impact energy and work frequency. The method is based on a simplified mathematical model of the breaker and has been validated by means of experimental test on commercial breakers.

**Keywords:** hydraulic breaker, rapid designing, functional design, nitrogen spring, impact energy

## **1. Introduction**

A hydraulic breaker is an indispensable device for demolition of artifacts, construction of any kind of civil infrastructures, mines excavation, and is often applied as an excavator tool. It is a machine able to

convert the hydraulic energy provided by a supply unit into mechanical energy, which is transmitted to a chisel in terms of cyclical percussions.

In the design and development phase of a new breaker, a dynamic model able to simulate its behavior could be an useful tool, allowing to study and optimize its performance. In this respect, Ficarella et al. (2006) highlighted already that scientific literature seems to be very scarce.

Some works are concerned with very detailed models, often implemented in commercial packages for simulation of hydraulic systems, which considers all single components of the device. Yan et al. (2010) proposed a model realized in ADAMS/Hydraulics, able to investigate the influence of the oil flow, accumulator pressure etc. on the working course of a piston. Giuffrida and Laforgia (2005) developed a model in the AMESim environment aimed at simulating the hydraulic circuit with reference to the real geometry of a commercial one, taking into account the real dimensions of the parts, the clearances, the bodies masses. Xu and Zhang (2009), studied the working performance of a hydraulic breaker considering in particular the viscous friction. Although this approach allows to realize very accurate models, their complexity makes it difficult to have a clear view of the main factors that influence the breaker performance.

Vice versa, in the preliminary project phase of a new machine, it may be convenient to make simplifications aimed at individuate those factors that influence the main breaker characteristics, like the impact energy and the work frequency.

In some cases, the number of parameters has been reduced by means of a dimensionless approach and similarity criteria. Gorodilov (2005) presented techniques of mathematical model-building for the hydraulic percussion systems. Gorodilov again (2000) analyzed the working cycle of a hydraulic breaker using similarity criteria, and the analogy method in which the factors defining the system are not considered separately, but in some combinations in the form of total effects, then deepening, in a subsequent work (2002), also the effect of an ideal distributor. In addition Gorodilov (2012, 2013) proposed a mathematical model of a two-way hydropercussion.

This paper presents a simplified model of a hydraulic breaker, aimed at supporting the designer in the determination of the main geometrical parameters, namely the dimensions of the piston and the gas spring. First a procedure for the functional design of the breaker, supported by a simplified model, is proposed, then the results of experimental tests for the validation of the design methodology, performed on commercial breakers, are shown.

## 2. The breaker working principle

This study considers hydraulic breakers whose impact energy is provided by a nitrogen spring. A breaker scheme is depicted in Figure 1.

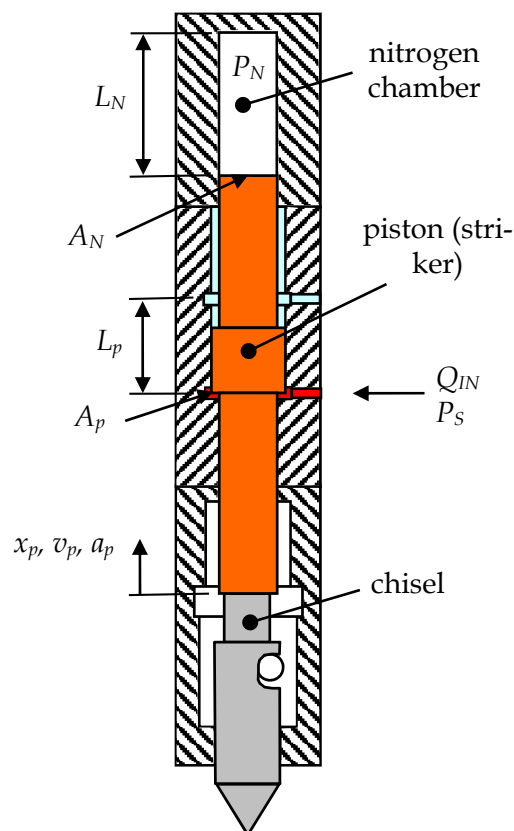

**Figure 1.** The hydraulic breaker scheme

The working cycle is divided in two phases.

First, by means of the automatic commutation of a valve (not shown in the figure), a hydraulic pump with supplying pressure  $P_S$  and flow rate  $Q_{IN}$  is connected to the lower chamber of a cylinder, causing the lifting of the piston with active area  $A_p$ . During the lifting stroke, a nitrogen chamber, with section  $A_N$  and pressure  $P_N$ , is charged to act as a gas spring (*phase 1*).

Then, when the piston lifting stroke reaches level  $L_p$ , a new automatic commutation of the distributor connects the lower chamber to discharge.

In this moment, since the upward thrust of the pressurized oil is missing, the push of nitrogen on the spring area causes the downward motion of the piston (*phase 2*) which reaches, just before impact, the maximum desired velocity  $|v_{pmax}|$ .

Finally the piston, acting as a striker, bumps against the chisel, which in turn will hit the object to be demolished, transferring the impact energy. At the end of phase 2 the cycle restarts from the beginning.

From energetic point of view, neglecting losses, first the hydraulic energy of the supplying pump is transferred to the nitrogen spring in form of potential elastic energy; subsequently the spring, discharging, gives back its elastic energy to the piston that, in downward stroke, acquires kinetic energy; finally the piston transfers energy to the chisel that must perform the mechanical demolition work.

### **3. The functional design**

In the first design step of a new hydraulic breaker, once the performance specifications have been defined, it is necessary to individuate the main functional characteristics that will constitute the starting point for the detailed design.

This article proposes a design tool with which the designer can calculate the stroke  $L_p$  and section  $A_p$  of the piston, the length  $L_N$  and section  $A_N$  of the nitrogen spring, starting from the flow characteristic of the supplying pump, in particular the value of the nominal flow rate  $Q_{IN}$ , and having fixed as design

specifications the value of the impact energy  $E_i$  that must be provided by the striker during impact and the desired work frequency  $f$ .

Hereinafter, first a simplified model aimed at the functional design of the breaker is described, then a dimensionless analysis of the system is presented, finally a complete designing procedure is proposed and the variation of the functional design parameters versus the dimensionless parameters is analyzed.

#### 4. The model

The proposed model considers lumped parameters, with ideal fluid, no mechanical friction and hydraulic resistance. Besides the operation of the switching valve is not taken into account. The whole modeling is made with the purpose of obtaining a simplified and explicit formulation, that can be used as a support for the rapid design of a new breaker.

In phase 1 of the working cycle, the pump supplies an oil flow rate  $Q_{IN}$  to the lower chamber of the cylinder, therefore the piston moves upward at a velocity  $v_{pu}$  that approximately can be considered constant. Thus the raising time  $t_u$  of the piston, to perform the upward stroke  $L_p$ , can be expressed as:

$$t_u = \frac{L_p A_p}{Q_{IN}} = \frac{L_p}{v_{pu}} \quad (1)$$

where

$$v_{pu} = \frac{Q_{IN}}{A_p} \quad (2)$$

is the average upward speed of piston.

Once the valve has switched the piston is subjected to the nitrogen spring pressure and starts the downward stroke (phase 2). In this condition the free-body diagram of the piston, neglecting weight, frictions, flow forces and back-pressures due to resistances of the hydraulic orifices, is the one depicted in Figure 2.

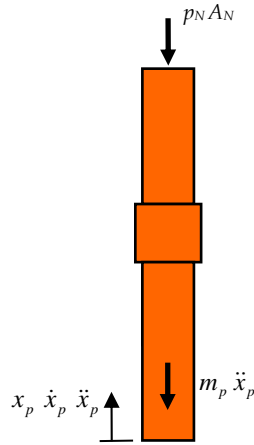

**Figure 2.** The free body diagram of the piston in phase 2

Consequently, the equilibrium equation is simply:

$$p_N A_N + m_p \ddot{x}_p = 0 \quad (3)$$

Where  $m_p$  is the mass of the piston.

Considering the high working frequency of the hydraulic breaker, the most appropriate model for the nitrogen spring would be adiabatic (Gorodilov 2002; Quaglia 2012), or, at most, a polytropic one (Giuffrida 2005; Ferraresi 2014). Assuming that the reduction of the chamber volume of a typical hydraulic breaker spring is about 20%, the adoption of an isothermal model rather than an adiabatic one underestimates the maximum pressure of nitrogen spring by approximately 8%. With the aim to simplify the model, we considered acceptable such an error in the case under study, and we decided to use an isothermal transformation for the nitrogen spring. Said  $P_{N0}$  the initial nitrogen pressure,  $V_{N0} = A_N L_N$  the initial spring volume, i.e. with piston fully lowered, one has:

$$P_N V_N = P_{N0} V_{N0} \quad (4)$$

hence, considering that:

$$V_N = V_{N0} - A_N x_p = A_N L_N - A_N x_p \quad (5)$$

the absolute spring pressure, at a generic position  $x_p$  of the piston, can be expressed as:

$$P_N = \frac{P_{N0}}{1 - x_p/L_N} \quad (6)$$

By substituting eqn. (6) into (3) and confusing the relative with the absolute pressure (acceptable assumption for quite high pressure in nitrogen chamber), it is possible to express the piston acceleration

$\ddot{x}_p$  in the downward stroke, at a generic position  $x_p$  of the piston:

$$\ddot{x}_p = - \frac{P_{N0} A_N}{(1 - x_p/L_N) m_p} \quad (7)$$

Integration of eqn. (7) leads to the downward velocity  $v_p = \dot{x}_p$  of the piston a generic position  $x_p$ :

$$\int_0^{v_p} v_p dv_p = - \frac{P_{N0} A_N}{m_p} \int_{L_p}^{x_p} \frac{1}{1 - x_p/L_N} dx_p \quad (8)$$

one has:

$$v_p = - \sqrt{\frac{2 P_{N0} A_N L_N}{m_p} \ln \left( \frac{1 - x_p/L_N}{1 - L_p/L_N} \right)} \quad (9)$$

Since the impact of the striker to the chisel occurs at the end of the downward stroke, imposing in eqn.

(9) the conditions of null stroke  $x_p=0$  and maximum velocity  $v_p=v_{pmax}$ , the impact energy can be expressed as:

$$E_i = \frac{1}{2} m_p v_{pmax}^2 = P_{N0} A_N L_N \ln \frac{1}{1 - L_p/L_N} \quad (10)$$



Finally, to express the falling time  $t_d$  of the piston, it is necessary to integrate the velocity as expressed in eqn (9):

$$t_d = \sqrt{\frac{m_p}{2P_{N0}A_N L_N}} \int_{0.95L_p}^0 \frac{1}{\sqrt{\ln\left(\frac{1-x_p/L_N}{1-L_p/L_N}\right)}} dx_p \quad (11)$$

Unfortunately, the integral in eqn. (11) cannot be solved in explicit form. With the aim of finding a compromise between accuracy and simplicity in modeling, we decided to assume a linear relation between the piston velocity  $v_p$  and its position  $x_p$ :

$$v_p = v_{p\max}(1 - x_p/L_p) \quad (12)$$

In order to calculate the falling time of the piston  $t_d$ , the velocity expressed by eqn (12) must be integrated. Taking into account that the falling velocity of the piston is null at the higher piston position  $L_p$ , the integral must be evaluated from a starting position close to the extreme one. Obviously, the falling time  $t_d$  depends on the choice of the integration limits. From the analysis of experimental tests, described in Section 7, it was found that choosing the starting position of the piston equal to the 95% of the total stroke  $L_p$ , the calculated falling times were consistent with the real ones.

$$t_d \approx \int_{0.95L_p}^0 \frac{1}{v_{p\max}(1 - x_p/L_p)} dx_p \approx -3 \frac{L_p}{v_{p\max}} \quad (13)$$

Remembering eqn. (10) one obtains:

$$t_d \approx \frac{3L_p}{\sqrt{\frac{2E_i}{m_p}}} \quad (14)$$

Through eqns. (1) and (14), the working frequency can be derived:

$$f = \frac{1}{t_u + t_d} \quad (15)$$

Finally, using the approximate expression (12) for the velocity  $v_p$ , through integration, it is possible to express, as a function of time, the piston position during the downward stroke:

$$x_p \approx L_p \left( 1 - 0.05 e^{-\frac{v_{p,max} t}{L_p}} \right) \quad (16)$$

## 5. The dimensionless model

In order to simplify the procedure for functional modeling, some dimensionless quantities are introduced in this section.

From eqn. (6) it is possible to express the dimensionless stroke of the piston  $K_L = L_p/L_N$  as a function of the maximum dimensionless pressure of the nitrogen spring  $K_{PN} = P_{Nmax}/P_{N0}$ , being  $P_{Nmax}$  the maximum pressure in the spring, reached at the piston maximum stroke  $x_p = L_p$ :

$$K_L = \frac{L_p}{L_N} = \frac{P_{Nmax}/P_{N0} - 1}{\frac{P_{Nmax}}{P_{N0}}} = \frac{K_{PN} - 1}{K_{PN}} \quad (17)$$

From (10), again as a function of the maximum dimensionless spring pressure  $K_{PN}$ , the dimensionless impact energy  $K_E$  can be derived:

$$K_E = \frac{E_i}{P_{N0} A_N L_N} = \frac{E_i}{P_{N0} V_{N0}} = \ln K_{PN} \quad (18)$$

The courses of  $K_L$  and  $K_E$  versus  $K_{PN}$  are reported in Figure 3.

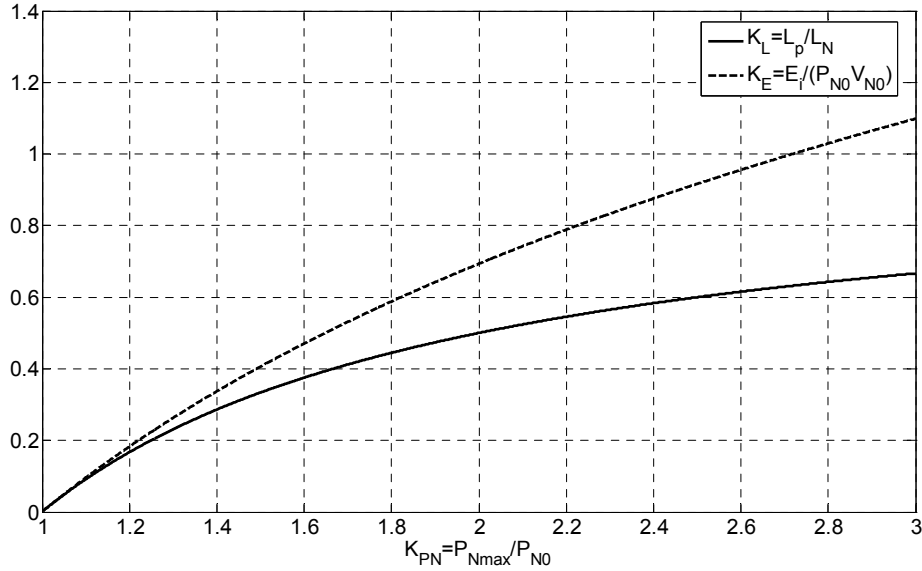

**Figure 3.** The dimensionless piston stroke  $K_L$  and the dimensionless impact energy  $K_E$  versus the dimensionless maximum pressure  $K_{PN}$  of the nitrogen spring

Now the velocity gain  $K_v$  is introduced, expressed as:

$$K_v = \frac{|v_{pmax}|}{v_{pu}} = \sqrt{\frac{E_i}{E_{pu}}} \quad (19)$$

which consists in the square root of ratio between the impact energy  $E_i$  obtainable from the analyzed breaker with respect to the impact energy  $E_{pu}$  obtainable from the same striker directly connected to the hydraulic supply unit.

The velocity gain allows to define two more dimensionless quantities, related to the dynamics of the system. First the dimensionless working frequency, representing the ratio between the piston rising time and the whole cycle period:

$$K_f = \frac{t_u}{t_u + t_d} = \frac{f}{1/t_u} = \frac{1}{1 + 3/K_v} \quad (20)$$

and also the ratio between raising and falling times  $K_t$ :

$$K_t = \frac{t_u}{t_d} = \frac{K_v}{3} \quad (21)$$

The course of dimensionless frequency  $K_f$  and the up/down time ratio  $K_t$  versus the gain velocity  $K_v$  are traced in Figure 4.

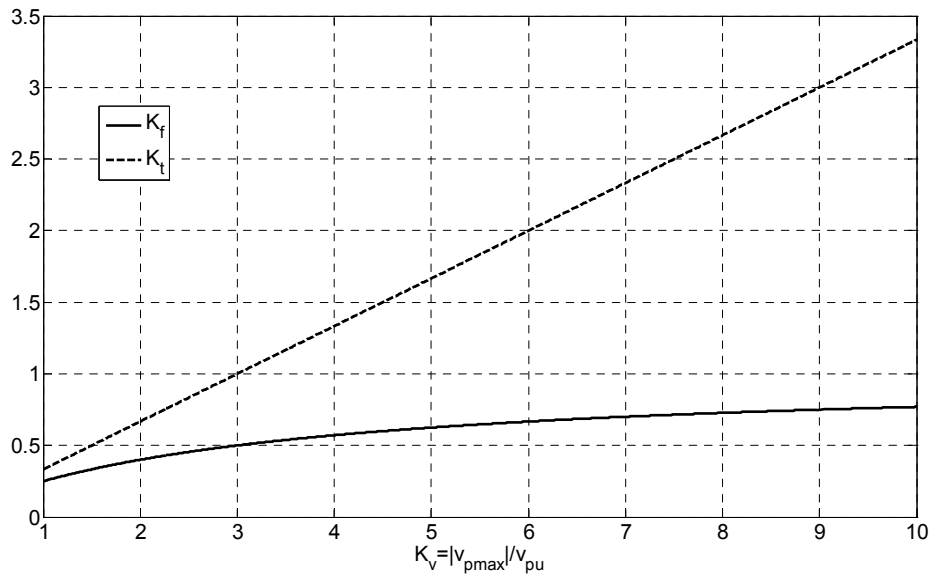

**Figure 4.** The dimensionless frequency  $K_f$  and the up/down time ratio  $K_t$  versus the gain velocity  $K_v$

## 6. The procedure for the functional design

Starting from the relationships of previous sections, a rapid design methodology has been conceived. It is depicted in Figure 5 and is divided in two stages.

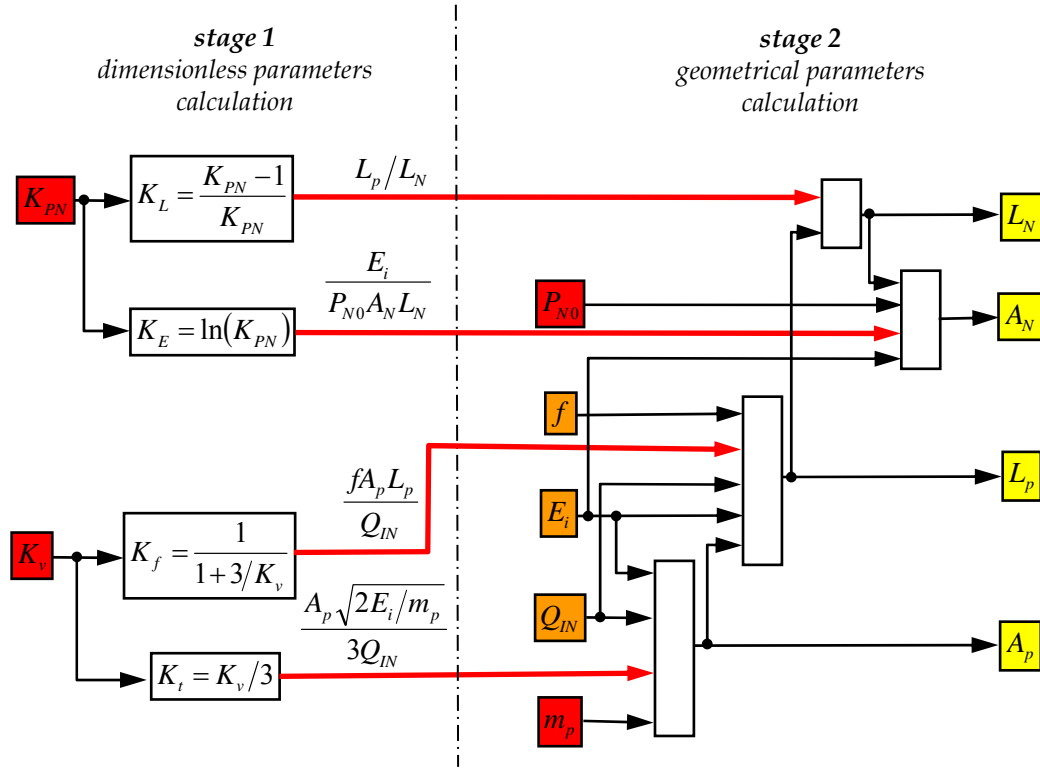

**Figure 5.** Block scheme of the rapid design process

In the first stage, the maximum dimensionless pressure of the nitrogen spring  $K_{PN}$  and the velocity ratio  $K_v$  must be fixed. The choice of initial value of these two parameters is a critical matter and claims for some discussion.

The value of  $K_{PN}$  is correlated with the impact energy  $E_i$  (see eqn. (18)). Therefore this latter benefits from high values of  $K_{PN}$ , once the value of preload energy of the nitrogen spring has been fixed. However, the pressure increasing cannot overcome some limits related to the system safety. Usual values for  $K_{PN}$  can be said as 1.3-1.5.

Also  $K_v$  is correlated with the breaker impact energy (see eqn. (19)). High values of this parameter correspond to large  $E_i$ , for a defined hydraulic power unit. However, when hydraulic unit has been defined, increasing values of  $K_v$  determine lower working frequencies, as evidenced by eqns. (19) and (20). Also in this case the value of  $K_v$  will be chosen on the base of a compromise. The order of magnitude for  $K_v$  can be said around 10.

Once the initial values of  $K_{PN}$  and  $K_V$  have been fixed, through eqns. (17), (18), (20) and (21) one can calculate the dimensionless stroke  $K_L$ , the dimensionless energy  $K_E$ , the dimensionless frequency  $K_f$  and the up/down time ratio  $K_t$ .

In the second stage the basic geometry of the breaker is determined. First the designer must impose the performance characteristics, namely the desired impact energy  $E_i$  and the working frequency  $f$ , together with the flow rate  $Q_{IN}$  of the supply unit. At the same time it is necessary to choose the initial pressure  $P_{NO}$  in the nitrogen spring and a tentative striker mass  $m_p$ .

By means of the mathematical relationships of the model, reported in Figure 5, it is then possible to calculate the geometrical parameters of the breaker, as concerns the piston (stroke  $L_p$  and active area  $A_p$  of the piston) and the nitrogen spring (length  $L_N$  and area  $A_N$  of the chamber).

## 7 Experimental validation

Some experimental tests have been carried out with the aim to verify the effectiveness of the rapid design process. The tests are related to a hydraulic breaker with nitrogen spring Vistarini VH160 installed on excavator Bobcat 331.

As concerns instrumentation, the nitrogen pressure  $P_N$  has been measured with a pressure transducer Parker PTDVB250 (full scale 100 bar; linearity  $< \pm 0.05\%$  f.s.; time response 1 ms); the supply flow rate  $Q_{IN}$  has been measured with a turbine flow sensor Flo-tech PFM6-60 (range 12÷227 l/min, accuracy  $\pm 1\%$  f.s.); the field signals have been acquired by means of National Instruments Board type DAQPad-6015 (BNC).

In the first step it has been necessary to validate the mathematical model of the breaker. To do that, starting from the experimental course of the nitrogen spring pressure, the piston position has been evaluated through eqn. (6); this allowed in turn to evaluate the experimental velocity and, from its maximum value, the impact energy.

On the other side, the model evaluated the theoretical position of piston in upward stroke assuming uniform linear motion, with velocity  $v_{pu}$  expressed by eqn. (2); conversely, the theoretical position in downward stroke has been calculated by eqn. (16).

The Figure 6 reports the course of the piston position as experimentally evaluated and theoretically calculated by the model. The good correspondence as concerns in particular the maximum values and the average dynamic trend certifies the validity of the mathematical model.

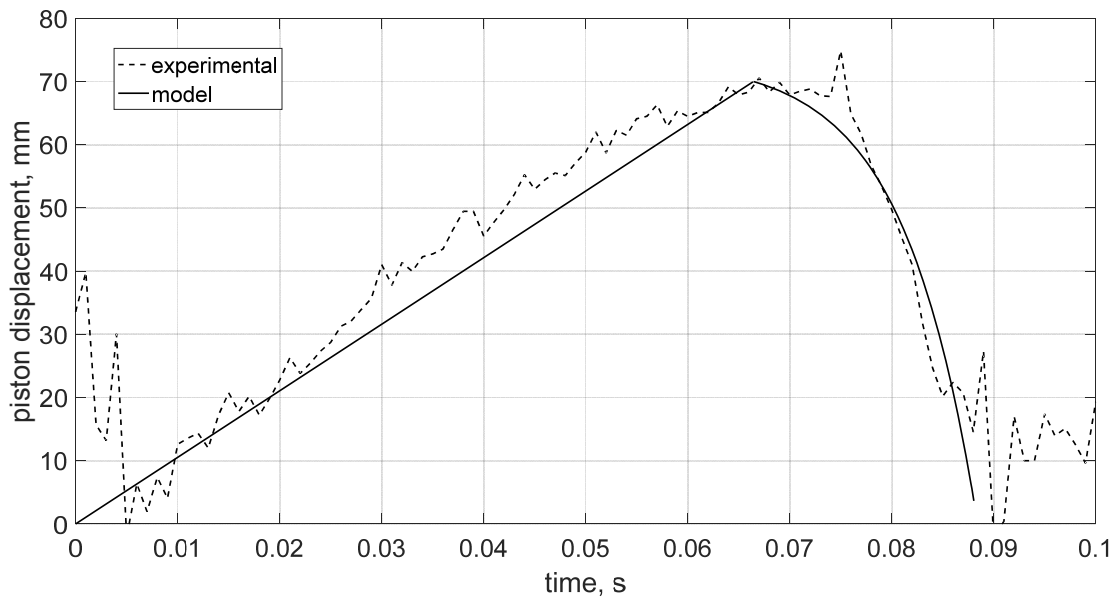

**Figure 6.** Comparison between the experimental and theoretical displacement of the piston

The experimental tests allowed also to complete the knowledge of the main functional parameters of the breaker, reported in table 1. In particular, by post processing the experimental pressure measures it was possible to obtain the initial nitrogen spring pressure  $P_{N0}$ , the maximum nitrogen spring pressure  $P_{Nmax}$ , and to calculate the dimensionless nitrogen spring pressure  $K_{PN}$ . The piston mass  $m_p$  was calculated from the drawings of the hammer. The mean up-velocity of the piston  $v_{pu}$ , and the impact velocity of the piston  $v_{max}$  were numerically calculated starting from the experimental displacement of the piston, and consequently the velocity gain  $K_v$  and the energy impact  $E_i$  were calculated. The experimental tests permitted also to measure the breaker working frequency  $f$  and the supply pump flow rate  $Q_{IN}$ .

TABLE 1. The main functional parameters of the real breaker Vistarini VH160

$P_{NO}$	21.0 $10^5$ Pa	$K_v$	8.88
$P_{Nmax}$	29.0 $10^5$ Pa	$f$	12.6 Hz
$K_{PN}$	1.38	$E_i$	413 J
$v_{pu}$	1.05 m/s	$Q_{IN}$	$5.66 \cdot 10^{-4}$ m <sup>3</sup> /s
$v_{max}$	9.33 m/s	$m_p$	9.5 kg

This enabled to apply the rapid design procedure described in section 3.3. Starting from the data of table 1, which constitute the design parameters, the geometrical characteristics of the breaker VH160 have been calculated in the way described above.

The table 2 reports the values of the four design parameters both as evaluated by the theoretical procedure and as detected from the real breaker. The third column reports the per cent difference. There is a very good correspondence as regards the piston and the nitrogen spring area; the volume of the spring is quite underestimated, but in the complex the effectiveness of the rapid design procedure can be confirmed.

TABLE 2. Theoretical and real design parameters for a nitrogen-spring breaker Vistarini VH160

	<b>Theoretical value (mm)</b>	<b>Real value (mm)</b>	<b>difference %</b>
$\Phi_p$	64.2	65.5	-1.9
$L_p$	62.3	62.0	+0.5
$\Phi_N$	58.6	60.0	-2.3
$L_N$	225.8	304.1	-34.7

A further validation of the methodology for rapid designing was made on another breaker model, the Vistarini VHX331, in this case starting from product catalog data (working frequency  $f$ , impact energy  $E_i$  and supply pump flow rate  $Q_{IN}$ ), manufacturer data (initial  $P_{NO}$  and maximum  $P_{Nmax}$  nitrogen spring pressure) and data taken from drawings (mass and dimensions). The mean up velocity piston  $v_{pu}$  was calculated using equation (2), knowing the pump flow rate  $Q_{IN}$  and the piston area  $A_p$ . The impact velocity of the piston  $v_{pmax}$  was calculated using the equation (10), knowing the catalog impact energy  $E_i$  and the piston mass  $m_p$ . Finally, starting from these data, the dimensionless nitrogen spring pressure  $K_{PN}$  and the velocity gain  $K_v$  were calculated (table 3).



The methodology for rapid designing, applied to the Vistarini VHX331 hammer, starting from the data of table 3, permitted to calculate the main geometrical characteristics of the breaker and to compare them to the real values (table 4).

TABLE 3. The main functional parameters of the real breaker Vistarini VHX331

$P_{NO}$	22.0 $10^5$ Pa	$K_v$	10.12
$P_{Nmax}$	29.0 $10^5$ Pa	$f$	13.2 Hz
$K_{PN}$	1.32	$E_i$	785 J
$v_{pu}$	1.22 m/s	$Q_{IN}$	$1.25 \cdot 10^{-3}$ m <sup>3</sup> /s
$v_{max}$	12.35 m/s	$m_p$	10.3 kg

TABLE 4. Theoretical and real design parameters for a nitrogen-spring breaker Vistarini VHX331

	<b>Theoretical value (mm)</b>	<b>Real value (mm)</b>	<b>difference %</b>
$\Phi_p$	83.0	70.0	+15.7
$L_p$	71.0	68.0	+4.2
$\Phi_N$	74.7	60.0	+19.7
$L_N$	294.2	303.1	-3.0

Also in this case, in the complex the effectiveness of the rapid design procedure can be confirmed. It must be indeed taken into account that the methodology allowed to calculate the main geometrical parameters of the Vistarini VHX331 hydraulic breaker with discrete approximation, although starting from necessarily uncertain initial data.

## 8 Influence of the dimensionless parameters on the functional parameters

The procedure of the functional design, described in section 6 and resumed in Figure 5, provides that the dimensionless parameters  $K_{PN}$  and  $K_v$  must be chosen a priori. In order to highlight the influence of these parameters on the functional geometrical dimensions of the hammer, the rapid design procedure has been applied assuming the design parameters collected in table 1, and varying the values of  $K_{PN}$  and  $K_v$ . Figure 7 reports the trend of the design parameters of the nitrogen-spring breaker Vistarini VH160 versus the dimensionless nitrogen spring pressure  $K_{PN}$ .

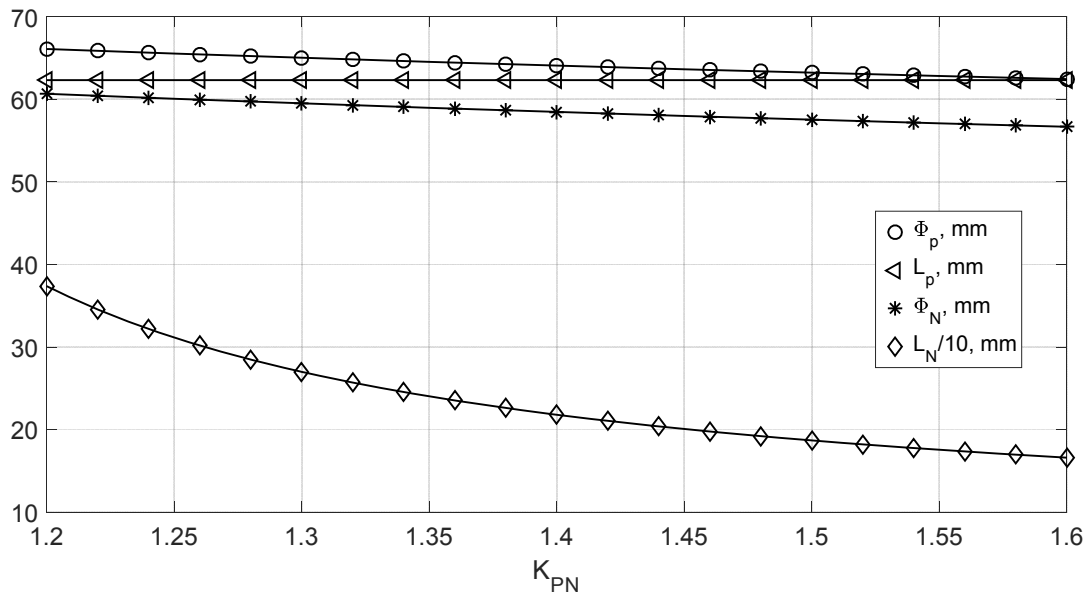

**Figure 7.** Design parameters of the nitrogen-spring breaker Vistarini VH160 versus the dimensionless parameter  $K_{PN}$

Figure 8 shows the behavior of the design parameters of the nitrogen-spring breaker Vistarini VH160 versus the dimensionless velocity ratio  $K_v$ .

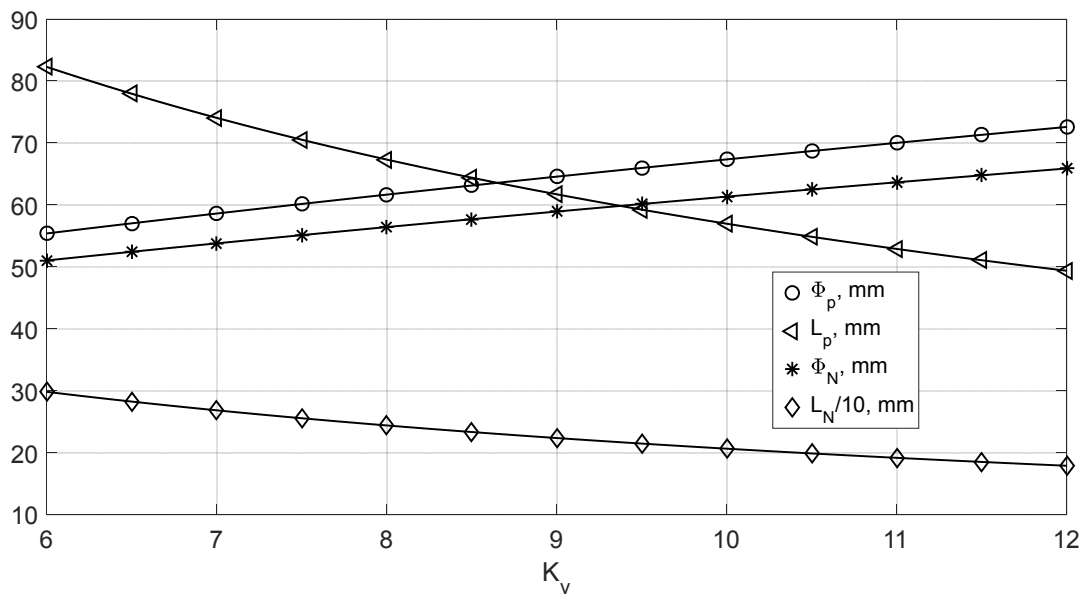

**Figure 8.** Design parameters of the nitrogen-spring breaker Vistarini VH160 versus the dimensionless parameter  $K_v$

From this analysis, it is clear that the nitrogen spring height  $L_N$  depends strongly on the dimensionless nitrogen spring pressure  $K_{PN}$ , while all the design parameters,  $(L_N, L_P, \Phi_N, \Phi_P)$  are heavily influenced by

the velocity gain  $K_v$ . Therefore high errors on the calculation of any of the geometrical functional design parameters can be caused by wrong estimation of the dimensionless parameters  $K_{PN}$  and  $K_v$ , as well as by neglecting friction and other possible losses.

## 9 Conclusions

In this work, first a simplified mathematical model of a hydraulic breaker with nitrogen spring has been realized, then the model has been used as the base of a procedure for the rapid design of new breakers. The procedure supports the designer in the definition of some parameters which are very influent on the dynamical performance of the breaker, like impact energy and working frequency.

Both the mathematical model and the rapid design procedure have been experimentally verified. The model has proved capable of simulating with good correspondence the dynamical course of the piston position during the working cycle. The design procedure allowed to foresee the dimensions of two piston-striker and nitrogen spring with a maximum difference of 34% with respect to the real dimensions of a commercial breaker.

In conclusion, the procedure was capable to individuate with acceptable accuracy a direct correlation between the main operating performances and some critical design parameters, and therefore could be adopted as a useful support in the first step of a new breaker development.

### Notes on contributors



Walter Franco is Assistant Professor in Applied Mechanics at the Department of Mechanical and Aerospace Engineering, Politecnico di Torino, Italy. His main research interests cover Hydraulics and Pneumatics, Robotics, Biomedical Engineering and Appropriate Technologies.



Carlo Ferraresi is Full Professor in Applied Mechanics at the Department of Mechanical and Aerospace Engineering, Politecnico di Torino, Italy. His main research interests are Robotics, Mechatronics, Biomedical Engineering and Appropriate Technologies.

## Nomenclature

A lowercase p indicates relative pressures, an uppercase P indicates absolute pressures. In the notation table only absolute pressures are reported.

$A_N$	nitrogen spring area
$A_p$	piston area
$E_i$	impact energy
$E_{pu}$	impact energy of a hydraulic striker
$f$	working frequency
$K_f$	dimensionless working frequency
$K_L$	dimensionless piston stroke
$K_{PN}$	dimensionless nitrogen spring pressure
$K_t$	up-down time ratio
$K_v$	velocity gain
$L_N$	nitrogen spring height
$L_p$	piston stroke
$m_p$	piston mass
$P_N$	nitrogen spring pressure
$P_{N0}$	initial nitrogen spring pressure
$P_S$	supply pressure
$Q_{IN}$	supply pump flow rate
$t_d$	down time (falling time)
$t_u$	up time (rising time)
$V_N$	nitrogen spring actual volume
$V_{N0}$	nitrogen spring initial volume
$v_p$	piston velocity
$v_{pmax}$	impact piston velocity
$v_{pu}$	mean up-velocity of the piston
$x_p$	piston position
$\Phi_N$	nitrogen spring diameter
$\Phi_p$	piston diameter

### **subscripts**

$0$	initial condition
$N$	nitrogen
$i$	impact
$p$	piston
$u$	up
$d$	down

## References

- Ferraresi C., Franco W., Quaglia G., 2014. A Novel Bi-Directional Deformable Fluid Actuator. *J. Mech. Eng. Sci.*, 228(15): 2799-2809.
- Ficarella A., Giuffrida A. and Laforgia D., 2006. Numerical Investigations on the Working Cycle of a Hydraulic Breaker: Off-Design Performance and Influence of Design Parameters. *Int. J. Fluid Power*, 7(3): 41-50
- Giuffrida A. and Laforgia D., 2005. Modelling and Simulation of a Hydraulic Breaker. *Int. J. Fluid Power*, 6(2): 47-56.

- Gorodilov L.V., 2000. Analysis of Working Cycle of Hydraulic Impact Machine Using Similarity criteria. *J. Min. Sci.*, 36(5): 476-480.
- Gorodilov L.V., 2002 Investigation into the Characteristics of Working Cycles of Hydraulic Percussive Machines with Ideal Distributor. *J. Min. Sci.*, 38(1): 74-79.
- Gorodilov L.V., 2005. Mathematical Models of Hydraulic Percussion Systems. *J. Min. Sci.*, 41(5): 475-489.
- Gorodilov L.V., 2012. Analysis of the Dynamics of Two-Way Hydropercussion Systems. Part I: Basic Properties. *J. Min. Sci.*, 48(3): 487-496.
- Gorodilov L.V., 2013 Analysis of the Dynamics of Two-Way Hydropercussion Systems. Part II: Influence of Design Factors and Their Interaction With Rocks. *J. Min. Sci.*, 49(3): 465-474.
- Quaglia G., Scopesi M., Franco W., 2012. A Comparison Between Two Pneumatic Suspension Architectures. *Vehicle Syst. Dyn.*, 50(4): 509-526.
- Xu T. and Zhang X., 2009. Viscous Friction Research to Hydraulic Hammer Working Performance By Simulation. In: International Conference on Intelligent Human-Machine Systems and Cybernetics, Hangzhou, Zhejiang, China, 26-27 August 2009
- Yan S. and Xu J., 2010. Study on Dynamic Characteristics of a Hydraulic Hammer. In: Third International Conference on Digital Manufacturing & Automation Changsha, Hunan, China, 18-20 December 2010

## FIGURE CAPTIONS

**Figure 1.** The hydraulic breaker scheme

**Figure 2.** The free body diagram of the piston in phase 2

**Figure 3.** The dimensionless piston stroke  $K_L$  and the dimensionless impact energy  $K_E$  versus the dimensionless maximum pressure  $K_{PN}$  of the nitrogen spring

**Figure 4.** The dimensionless frequency  $K_f$  and the up/down time ratio  $K_t$  versus the gain velocity  $K_v$

**Figure 5.** Block scheme of the rapid design process

**Figure 6.** Comparison between the experimental and theoretical displacement of the piston

**Figure 7.** Design parameters of the nitrogen-spring breaker Vistarini VH160 versus the dimensionless parameter  $K_{PN}$

**Figure 8.** Design parameters of the nitrogen-spring breaker Vistarini VH160 versus the dimensionless parameter  $K_v$