

Modelling of a safety relief valve through a MATLAB-Simulink and CFD based approach

Original

Modelling of a safety relief valve through a MATLAB-Simulink and CFD based approach / DALLA VEDOVA, MATTEO DAVIDE LORENZO; Maggiore, Paolo; Riva, Giorgio. - In: WSEAS TRANSACTIONS ON FLUID MECHANICS. - ISSN 1790-5087. - ELETTRONICO. - 11:(2016), pp. 173-178.

Availability:

This version is available at: 11583/2659162 since: 2016-12-13T16:08:52Z

Publisher:

WSEAS Press.

Published

DOI:

Terms of use:

This article is made available under terms and conditions as specified in the corresponding bibliographic description in the repository

Publisher copyright

(Article begins on next page)

Modelling of a safety relief valve through a MATLAB-Simulink and CFD based approach

M. D. L. DALLA VEDOVA P. MAGGIORE G. RIVA

Department of Mechanical and Aerospace Engineering

Politecnico di Torino

Corso Duca degli Abruzzi 24 – 10129, Turin

ITALY

matteo.dallavedova@polito.it

Abstract: - The aim of the work is to understand the proper way to address the design and optimization procedures of a hydraulic safety relief valve. These valves are a part of the hydraulic circuit of many aircraft models, so their performances must be adapted to the specific system or engine. The only real constraints are the geometrical dimensions and the need to limit the weight of the device. This work requires gathering all the possible information available in the literature, and condensing them in a set of operations that will allow to promptly manufacture a product fitting the requirements needed. This should lead to the reduction of the amount of physical prototypes needed to obtain testing devices. The process studied uses a numerical fluid dynamic calculation approach to define the pressure field inside the valve and the forces acting on it, together with a Computational Fluid Dynamic (CFD) calculation used to identify the force distribution inside the valve. The first step deals with the creation of a CAD model of the valve. Then the CAD is imported into the CFD software, which evaluates the pressure field required to calculate the forces acting on the poppet of the valve. After the numerical scheme has been calibrated, some investigations are done to reduce the computational cost: the final goal is to run a complete simulation (meshing and solving) on a standard (even if high-end) laptop or desktop PC. Some of the positions (i.e. strokes) of the valve have been simulated as static, so a steady-state condition has been applied to solve the motion field. The main result consists of creating a MATLAB-Simulink® model capable to reach results comparable to that obtained by the CFD simulation, but in faster times. This means relying on a first-guess instrument, capable to address an initial design geometry. The further use of the Look-Up Tables (LUTs) increases the time required to obtain a solution, but links the Simulink model to the CFD simulation in order to reduce the amount of modeled quantities in favor of a greater precision of the model.

Key-Words: - Pressure relief valve, hydraulic system, lumped parameters numerical model, orifice flow, steady CFD, quasi-dynamic numerical simulation.

1 Introduction

A safety relief valve (also known as pressure relief valve, or PRV) is a simple but extremely important device, needed to ensure the desired level of pressure inside a hydraulic circuit. In fact, in many applications (i.e. not only strictly aeronautical, but also mechanical or industrial in general), pressure inside a system could build up past a desired threshold, damaging or even the destructing the system itself. This is the case of a cold-start of an engine, when the oil is not viscous enough to ensure the creation of a protective layer of fluid around the mechanical components, or of an industrial machine, where an excessive amount of pressure could generate water hammers. Discharging a burst of oil on the internal components could heavily damage the machine or the workpieces.

Figure 1 defines the general structure of a typical hydraulic circuit, highlighting all the main components. Oil is collected from a tank (S) by a pump driven by a motor (M), then flows to a check valve (N). An accumulator (A) avoids pressure fluctuations and ensures a power backup (for a limited time) in case of failure of the pump. Oil flows through a pressure regulating valve (E) and a filter (F), but a way back to the tank (S) is ensured by the safety relief valve (B). Then the fluid moves into the valve (C) and is diverted in the desired chamber of the jack (T) or directly sprayed on the gearing of an engine/tool machine to lubricate it. The final destination of the oil depends on the specific application analyzed, but any kind of circuit needs a relief valve to reduce the excess pressure.

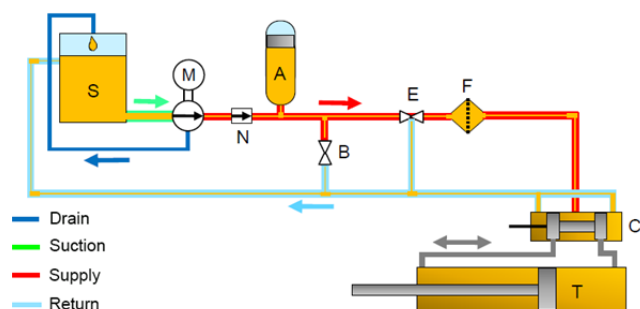

Fig. 1: General structure of a hydraulic circuit

The working principle of a pressure relief valve is quite simple, and the generic outline of this kind of valve can be found in Figure 2.

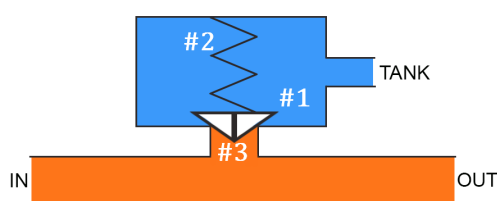

Fig. 2: Schematic view of a pressure relief valve

In particular, the aforesaid PRV is schematically composed by a moving element, called poppet (#1), pushed down by a spring (#2) that holds it in position inside a seat (#3). When the pressure of the supply line (orange zone of Fig. 2) is lower than a defined value (cracking pressure) the preload of the spring prevents the movement of the poppet, so the oil cannot flow. As the cracking pressure is reached, the valve poppet slides back in a way which is proportional to the amount of force generated; this opening value can be set by preloading the spring with a desired degree of compression: usually this happens through a screw fitted over the spring itself.

2 Experimental Setup

A test bench has been used to simulate a generic real-life hydraulic circuit. The prototype of a generic valve has been created to generate a set of experimental data used to compare the simulations' results. In order to obtain a relationship between the stroke (x) of the poppet, the mass flow of the oil (Q) and the pressure drop (Δp) inside the valve orifice, the following equation has been used:

$$Q = C_d A(x) \sqrt{\frac{2\Delta p}{\rho}} \quad (1)$$

where $A(x)$ represents the area of the orifice available for the oil flow; it must be noted that this variable area can be calculated as follows:

$$A(x) = \pi dx \quad (2)$$

The geometrical dimensions of the valve are reported in Fig. 3; in particular, d represents the inlet diameter of the abovementioned valve.

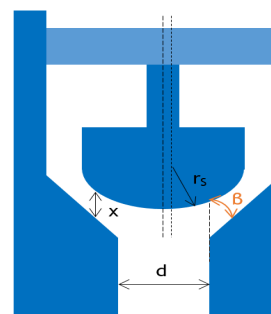

Fig. 3: Schematic of the considered pressure relief valve and description of its main characteristic dimensions

It is important to clarify the meaning of the coefficient indicated as C_d in (1): it is indeed the discharge coefficient, which represents the role of the geometry of the valve. Hence it indicates the capability of the device itself to allow a defined flow of oil in base to the interaction between pressure and density of the fluid (together with the available outflow area). This coefficient was first studied experimentally by Richard von Mises [1-2] and then evaluated analytically by Mikhail I. Gurevich [3].

Since the experimental rig uses a fixed displacement pump, the oil flow regulation is made by a series of valves, making it possible to vary the flow rate. Then the manual movement of the poppet through a screw defines the pressure that will be measured across the valve. In this case, given that a fixed spacer is used instead of the spring, the position of the poppet is measured by means of proportion between the pitch of the screw and the amount of turns of the screw itself. This generates a setting which is as stationary as possible, in order to obtain an experimental setting consistent with the CFD simulations. As the screw is turned, the poppet rises from the closed position to the fully opened one, making it possible to record the amount of pressure created for the specific flow rate and stroke. The values are recorded in an Excel® table and plotted to obtain a Δp - Q characteristic, which allows the calculation of the discharge coefficient. Pressure is measured via digital manometers and flow rate is measured with a flow meter. The same results are searched in the CFD simulations and in the simplified model used in MATLAB-Simulink, hence it is required to build a proper and reliable setup, capable to prove that the simulations can substitute the real-life prototypes.

3 CAD Geometry, Mesh Generation and CFD Simulation Settings

The geometry of the valve has been modelled in SolidWorks® 2015, used to generate an assembly made out by the valve body and the poppet. The assembly has been saved with the poppet located in four different positions¹, in order to reproduce the situation experimented with the test rig (schematically shown in Fig. 1); it must be noted that the main geometrical dimensions used to parameterize the valve are highlighted in Fig. 3. An algorithm was used to extract the fluid volume from the solid geometry (shown in Fig. 4)

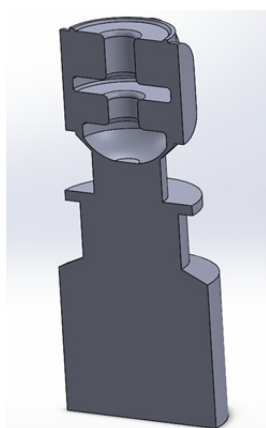

Fig. 4: Example of fluid volume extracted from the solid geometry of the pressure relief valve

Once the model is defined, it is needed to generate a mesh that can be used by OpenFOAM® in order to execute the fluid dynamic simulations. A tetrahedral mesh has been chosen, since it is reliable and capable to generate the calculation grid without an excessive computational effort. The mesh diagnostic tool of OpenFOAM® confirms the good quality of the cells and of the overall grid, as no interpenetrating cells or misaligned normal face vectors are found.

The valve is quite compact, but in order to obtain a good precision while executing the fluid dynamic calculations the number of cells used, since the domain is three-dimensional, ranges from 3 to 6 millions. The grid is made finer in the area of the orifice, since the very limited stroke (the useful value of poppet displacement x is always below 1 mm, even in maximum mass flow conditions) generates a very little outflow area.

¹ It must be noted that the number of steps tested must be defined in base to the linearity of the considered phenomenon and to the amount of resolution required to optimally fit the experimental data, but a linear characteristic can just require a small amount of points.

Having enough cells is paramount to allow a proper calculation of the strong gradients occurring inside the orifice, but at the same time a too fine subdivision of the domain would increase too much the computational time, wasting precious resources. The pressure field is integrated all over the poppet to obtain the distribution of forces required to size the spring and properly evaluate the stroke of the poppet itself.

4 CDF Results

The results obtained through the CFD simulations, as shown for instance in Fig. 5 and 6, have been compared with experimental results in order to evaluate the accuracy of the proposed approach. Pressure reaches the maximum value where the velocity of the fluid is nearly zero, while decreases as the velocity of oil increases.

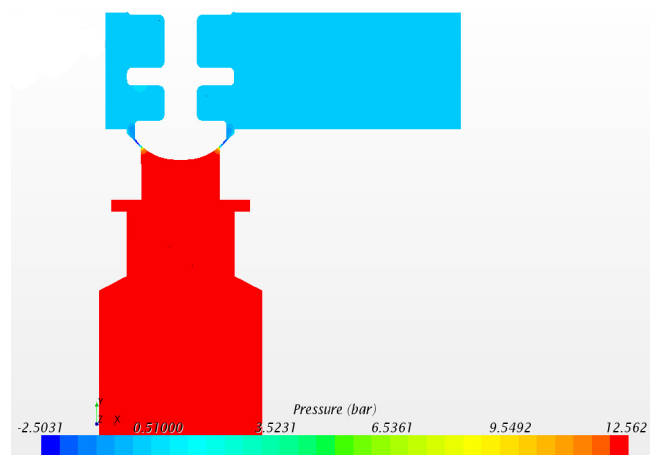

Fig. 5: Pressure profiles calculated by CFD simulation: $Q = 30$ [l/min] - Poppet Stroke $x = 0,398$ [mm]

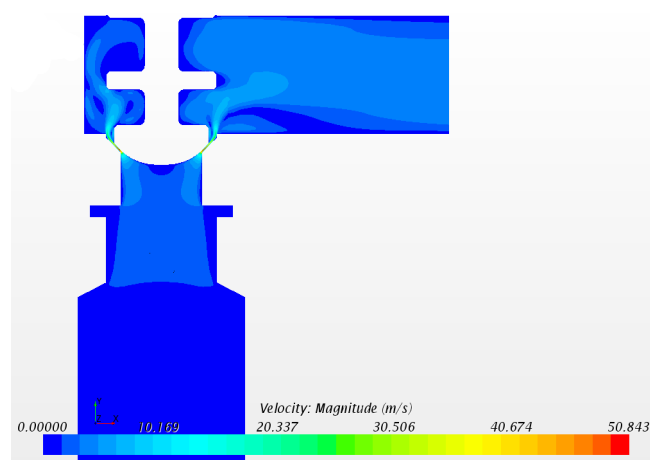

Fig. 6: Velocity profiles obtained by the CFD simulation: $Q = 30$ [l/min] - Poppet Stroke $x = 0,398$ [mm]

It is important to point out the negative values of absolute pressure obtained in the initial simulations. Such results are due to the fact that simulations are run as single phase ones, so it is not possible to accurately capture the phenomenon of bubble formation in certain areas of the valve [5-8].

5 MATLAB-Simulink® Model

Once defined the force and pressure fields acting on the poppet, it is important to analyze the dynamic behaviors of the mechanical components of the valve (i.e. the moving poppet driven by the spring). The properties of these components (poppet inertia, spring stiffness, viscous damping and dry friction) will determine the dynamic behavior of the valve, and its regulation field (e.g. acting on the spring preload the PRV's cracking pressure changes). To this purpose, a simplified numerical model has been developed in MATLAB-Simulink® simulation environment (shown in Fig. 7): it is able to simulate the dynamic behavior of the aforesaid PRV taking into account the effects of the mechanical properties of its components. It must be noted that it is a lumped parameter numerical model (i.e. spatially distributed entities of the examined physical system are condensed into a specific set of discrete elements, simplifying its real nature).

A data file is used to initialize the variables representing the geometry of the valve studied. At the same time two different calculation paths can be followed: indeed, forces used by the equations of dynamics can both be modeled (starting directly from physical or mathematical models given by literature) or interpolated by means of suitable look-up tables (LUT) containing the values calculated by the CFD simulations (e.g. the discharge coefficient C_d related to different values of poppet stroke x , oil mass flow Q and pressure drop Δp)

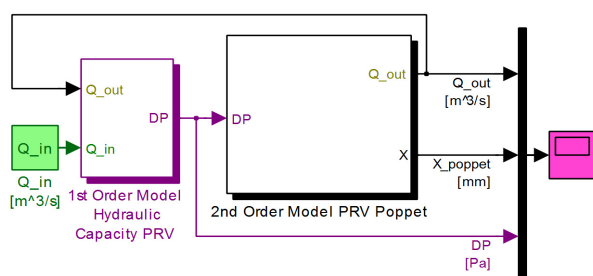

Fig. 7: MATLAB-Simulink block diagram of the PRV

The main forces used in the model are the flow force, the static pressure force, the dry friction (simulated by means of the Borello's model [9]) and the inertial force due to the mass of the poppet.

The CFD is able to consider the contributions due to pressure as a single term (inclusive of the effects of static pressure, friction and flow forces), while the direct modelling needs to take into account static pressure and dynamic pressure as two different contributions. It must be noted that, according to [10-12], the abovementioned flow force represents the reduction in pressure operated by the motion of the fluid inside the oil, which decreases the overall value of pressure to an extent that acts as a recall force, limiting the stroke of the poppet. In particular, as proposed by Heraković [10], in case of small stroke ($< 0,2$ [mm]) the flow force is modeled as:

$$F_{flow} = 2 \cdot C_d(x) \cdot \Delta p \cdot \cos\theta \cdot A(x) \quad (3)$$

where C_d is the discharge coefficient, θ is the outflow angle of the jet produced inside the orifice (seat-poppet area), Δp is the pressure drop through the valve orifice, $A(x)$ is the area of the orifice and x is the stroke of the poppet. Vice versa, in case of larger stroke x , the flow force is modeled as:

$$F_{flow} = \rho \cdot C_d^2(x) \cdot Q^2 \cdot \cos\theta / A(x) \quad (4)$$

In order to simulate the behavior of the valve, a quasi-dynamic scheme was chosen. This approach, proposed by Borello and Dalla Vedova in [13], is capable to handle complex systems of non-linear equations with reasonable ease, identifying by means of numerical calculation the corresponding stationary conditions. In fact the system uses the same equation as the dynamics, but the real physical meaning of the damping constants is neglected, in fact they are only used to allow a fast and numerically stable convergence to the regime condition of the system studied. It must be noted that, as shown in [14], such numerical scheme can find application also in other disciplines, like structural calculations. This kind of algorithm hence ensures fast convergence times (thanks to a suitable configuration of the constants), but also a high quality of the results, even if the transient loses its physical meaning.

6 MATLAB-Simulink® Results

Figures 11, 12 and 13 show the behavior of the proposed lumped numerical model, calculated for different mass flows Q . It must be noted that the considered mass flow Q (that flows through the valve) varying from 9,96 to 64,97 [l/min].

The parameters taken into account for the MS simulations are reported in Table 1 and the related color scheme is shown in Table 2.

Table 1: Parameters of the MATLAB-Simulink model

Parameter	Physical variable	Value	Units
K	spring stiffness	9,15	[N/mm]
C	damping coefficient	50	[N.s/m]
m	poppet's mass	0,01	[kg]
Dt	integration time step	1e-6	[s]
t	total simulation time	0,1	[s]

Table 2: Color scheme of MATLAB-Simulink model

Color	Physical variable	Units
Yellow	output mass flow	[l/min]
Pink	input mass flow	[l/min]
Cyan	leakage mass flow	[l/min]
Green	stroke of the poppet	[mm]
Red	pressure at the inlet	[bar]
Blue	cracking pressure	[bar]
Yellow (horizontal line)	maximum allowed stroke of the poppet	[mm]

It must be noted that, as reported in Table 3, all the considered cases (i.e. all the mass flows sets) are able to fit well the experimental results obtained. This means that the direct model of the flow force implemented in MS is able to synthetically capture the behavior of the fluid inside the valve.

Table 3: Comparison between experimental results and MATLAB-Simulink® simulations

Q [l/min]	P _{sim} [bar]	x _{sim} [mm]	P _{exp} [bar]	x _{exp} [mm]	%p	%x
64,97	13,41	0,7757	13,56	0,748	1,11	3,70
49,6	11,89	0,6483	12,09	0,629	1,65	3,07
29,96	10,19	0,4765	10,22	0,464	0,29	2,69
9,96	8,22	0,2912	8,4	0,2903	2,14	0,31

7 Conclusions

A 3D model of the full geometry of the valve has been developed to predict the distribution of pressures (hence forces) inside it to make an optimization process possible. The CFD calculations have been run with an open source software, OpenFOAM®. The mesh has been refined to take into account different strokes and various levels of accuracy of the results, in order to obtain a representation of the domain as accurate as possible.

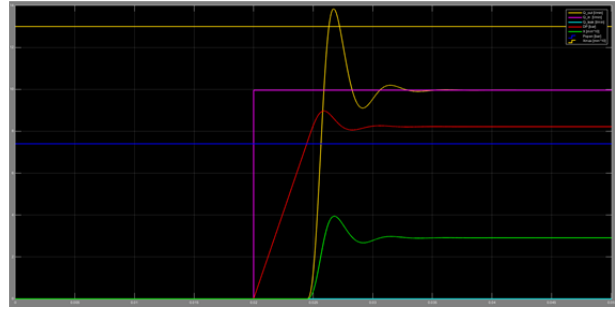

Fig. 10: MS simulation results for Q = 9,96 [l/min]

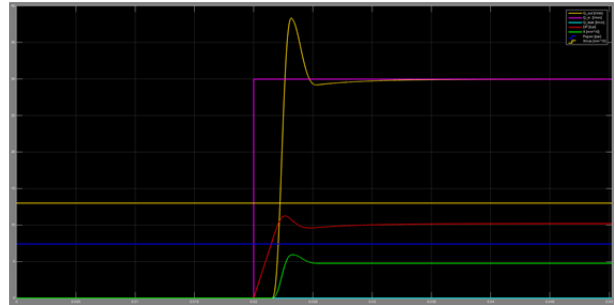

Fig. 11: MS simulation results for Q = 29,98 [l/min]

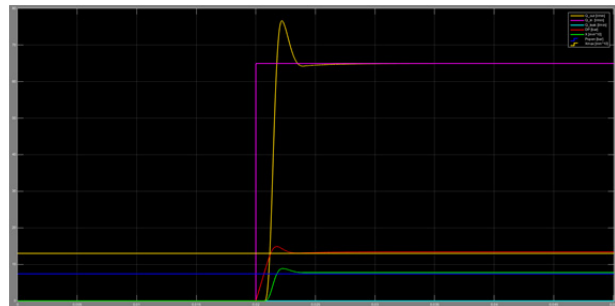

Fig. 12: MS simulation results for Q = 64,97 [l/min]

The meshing procedure was based on a trials and errors procedure, driven by previous examples found in literature [15]. The results show a good behavior of the MATLAB-Simulink® model for both the fully CFD modelled and CFD/Simulink interactive model. As a more accurate representation of the valve through the CFD will be reached, the sole MATLAB-Simulink® model could be enough to drive the very initial stages of the design, providing the preliminary information necessary to aim the successive detailed optimization procedure based upon extensive use of CFD-driven calculations. Clearly a full and accurate comprehension of the best geometry fitting the characteristics of flow rate and pressure can be reached only via the CFD, as a precious and cost-effective alternative to a purely practical approach. The results obtained by the initial CFD setting require a deeper analysis to clarify the need to use a more complex and rich simulation, with the use of a multiphase model.

In particular, the multiphase survey could also raise the need to introduce a cavitation model, thus making the model much more detailed and complex. To this purpose, authors are intended to continue this research developing more accurate numerical simulations based upon Matlab-SIMULINK® models enriched with look-up tables and, then, comparing them with a pure CFD dynamic simulation, created taking into account a multiphase fluid.

References:

- [1] R. von Mises, *Berechnung von ausfluß und ueberfallzahlen*, Zeitschrift des Vereine Deutscher Ingenieure, 1917 (in German).
- [2] R. Von Mises, *The calculation of flow coefficient for nozzle and orifice*, VDA, Vol.61, 1917, pp. 21-23.
- [3] M. I. Gurevic, *Theory of jets in ideal fluids*, Academic Press, 1965.
- [4] Nekropolistov Society, *OpenFOAM User Guide – Online*, 2016.
- [5] S. I. Bernad, R. Susan-Resiga, Numerical model for cavitational flow in hydraulic poppet valves, *Modelling and Simulation in Engineering*, 2012.
- [6] P. Zwart, A. G. Gerber, T. Belamri., A Two-Phase Model for Predicting Cavitation Dynamics, *ICMF 2004 International Conf. on Multiphase Flow*, 2004, Yokohama, Japan.
- [7] J. Sauer, G. H. Schnerr, W. Yuan, Modeling and computation of unsteady cavitation flows in injection nozzles, *Mecanique et Industries*, Vol.2, No.5, 2001, pp. 383-394.
- [8] A. C. Bayeul-Lainé, S. Simonet, D. Dutheil, G. Caignaert, Numerical study of cavitating flow inside a flush valve, *Mecanique et Industries*, Vol.12, No.6, 2011, pp. 421-431.
- [9] L. Borello, M. D. L. Dalla Vedova, A Dry Friction Model and Robust Computational Algorithm for Reversible or Irreversible Motion Transmission, *International Journal of Mechanics and Control (JoMaC)*, Vol.13, No.2, 2010, pp. 37-48.
- [10] N. Herakovič, Flow-force analysis in a hydraulic sliding-spool valve, *Strojarstvo*, Vol.49, No.3, 2007, pp. 117-126.
- [11] M. Šimic, N. Herakovič, Reduction of the flow forces in a small hydraulic seat valve as alternative approach to improve the valve characteristics, *Energy Conversion and Management*, Vol.89, 2015, pp. 708-718.
- [12] N. Herakovič, J. Duhovnik, M. Šimic, CFD simulation of flow force reduction in hydraulic valves, *Tehnicki Vjesnik*, Vol.22, No.2, 2015, pp. 453-463.
- [13] L. Borello, M.D.L. Dalla Vedova, Pseudo-dynamic simulation method solving hydraulic stationary problems, *International Journal of Mechanics and Control (JoMaC)*, Vol.8, No.2, December 2007, pp. 43-52.
- [14] L. Borello, M.D.L. Dalla Vedova, A pseudo-dynamic approach to a simple example of structural static problem, *XX AIDAA National Congress*, 2009, Milano (Italy).
- [15] L. Pace, M. Ferro, F. Fraternali, A. Caimano, P. Maggiore, M. D. L. Dalla Vedova, Comparative analysis of a hydraulic servo-valve, *International Journal of Fluid Power*, Vol.14, 2013, pp. 53-62, ISSN: 1439-9776.