

Development of a new hybrid bus for urban public transportation

*Original*

Development of a new hybrid bus for urban public transportation / Millo, F., Rolando, L., Fuso, R., Zhao, J.. - In: APPLIED ENERGY. - ISSN 0306-2619. - STAMPA. - 157:(2015), pp. 583-594. [10.1016/j.apenergy.2015.03.131]

*Availability:*

This version is available at: 11583/2656765 since: 2016-11-21T15:22:05Z

*Publisher:*

Elsevier Ltd

*Published*

DOI:10.1016/j.apenergy.2015.03.131

*Terms of use:*

This article is made available under terms and conditions as specified in the corresponding bibliographic description in the repository

*Publisher copyright*

Elsevier preprint/submitted version

Preprint (submitted version) of an article published in APPLIED ENERGY © 2015,  
<http://doi.org/10.1016/j.apenergy.2015.03.131>

(Article begins on next page)

## Highlights

- New plug-in series hybrid electric powertrain developed for revamping old urban buses
- Assessment of its performance through experimental tests in real world operating conditions
- Impressive energy and operating costs savings vs conventional buses highlighted

Figure 1: Scheme of the main hybrid powertrain components.

Figure 2: HYBUS prototype rendering.

Figure 3: HYBUS prototype production: original bus (top left); removal of the old 9.5 liter diesel engine from the rear section of the vehicle (top right); installation of the APU (bottom, left); first HYBUS prototype (bottom right).

Figure 4: Route 18-forward: real mission profile.

Figure 5: Route 18-forward: SOC profile.

Figure 6: Route 63-forward: real mission profile.

Figure 7: Route 63-forward: SOC profile.

Figure 8: ICE working points on Route 63.

Figure 9: Model validation: SOC trends on Route 18-forward.

Figure 10: Model validation: cumulative fuel consumption on Route 18-forward.

Figure 11. Model validation: ICE working points on the Brake Specific Fuel Consumption (BSFC) map versus engine speed and load (shown as Brake Mean Effective Pressure, BMEP).

Figure 12. DP Optimization: SOC variation over a real driving cycle.

Figure 13. DP Optimization: Power requested to ICE.

Figure 14. DP Optimization: Operating points of the ICE on the Brake Specific Fuel Consumption (BSFC) map versus engine speed and load (shown as Brake Mean Effective Pressure, BMEP).

Figure 15. DP Optimization: Operating modes selected by the DP over a real driving cycle.

Figure 16. Operating modes selected by the DP plotted on an EM speed vs requested power map.

Figure 17. Operating modes selected by the DP plotted on a vehicle acceleration vs vehicle speed map.

**Figure 18. Battery SOC comparison over the complete real driving cycle.**

**Figure 19. Comparison of operating points of ICE on the Brake Specific Fuel Consumption (BSFC) map versus engine speed and load (shown as Brake Mean Effective Pressure, BMEP).**

**Figure 20. Cumulative fuel consumption comparison over the complete driving cycle.**

Figure1

[Click here to download high resolution image](#)

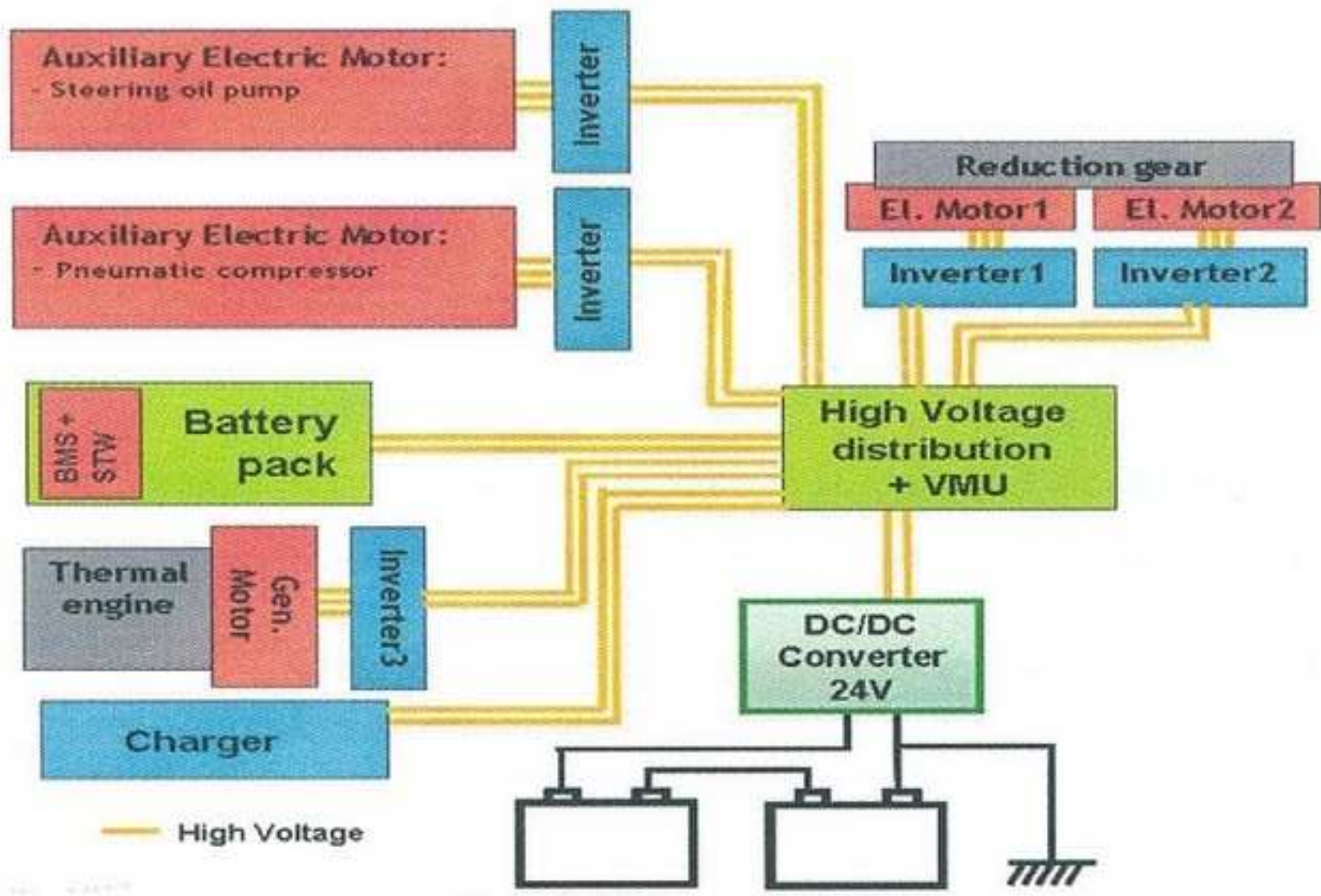

Figure2

[Click here to download high resolution image](#)

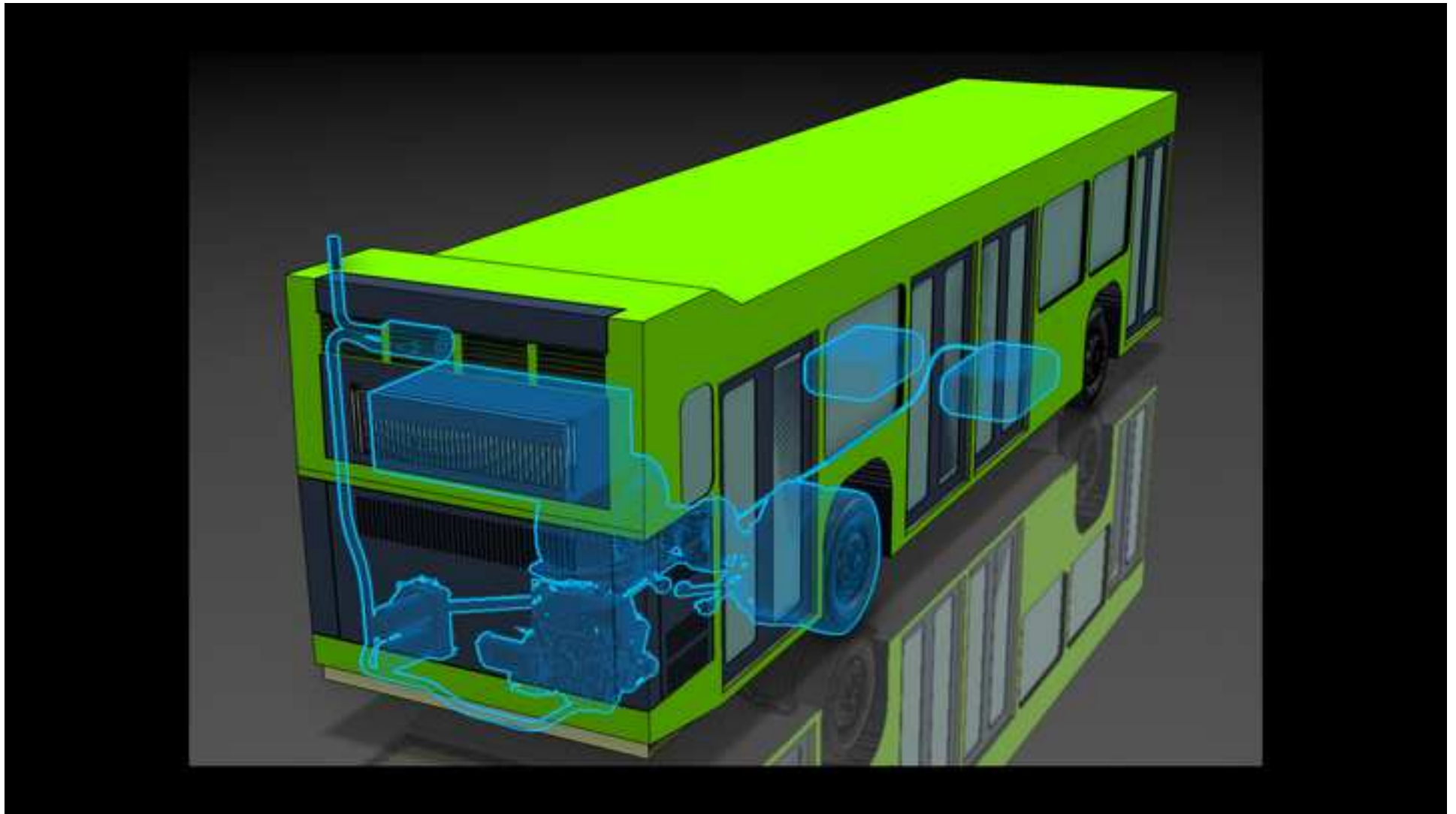

Figure3

[Click here to download high resolution image](#)



Figure4  
[Click here to download high resolution image](#)

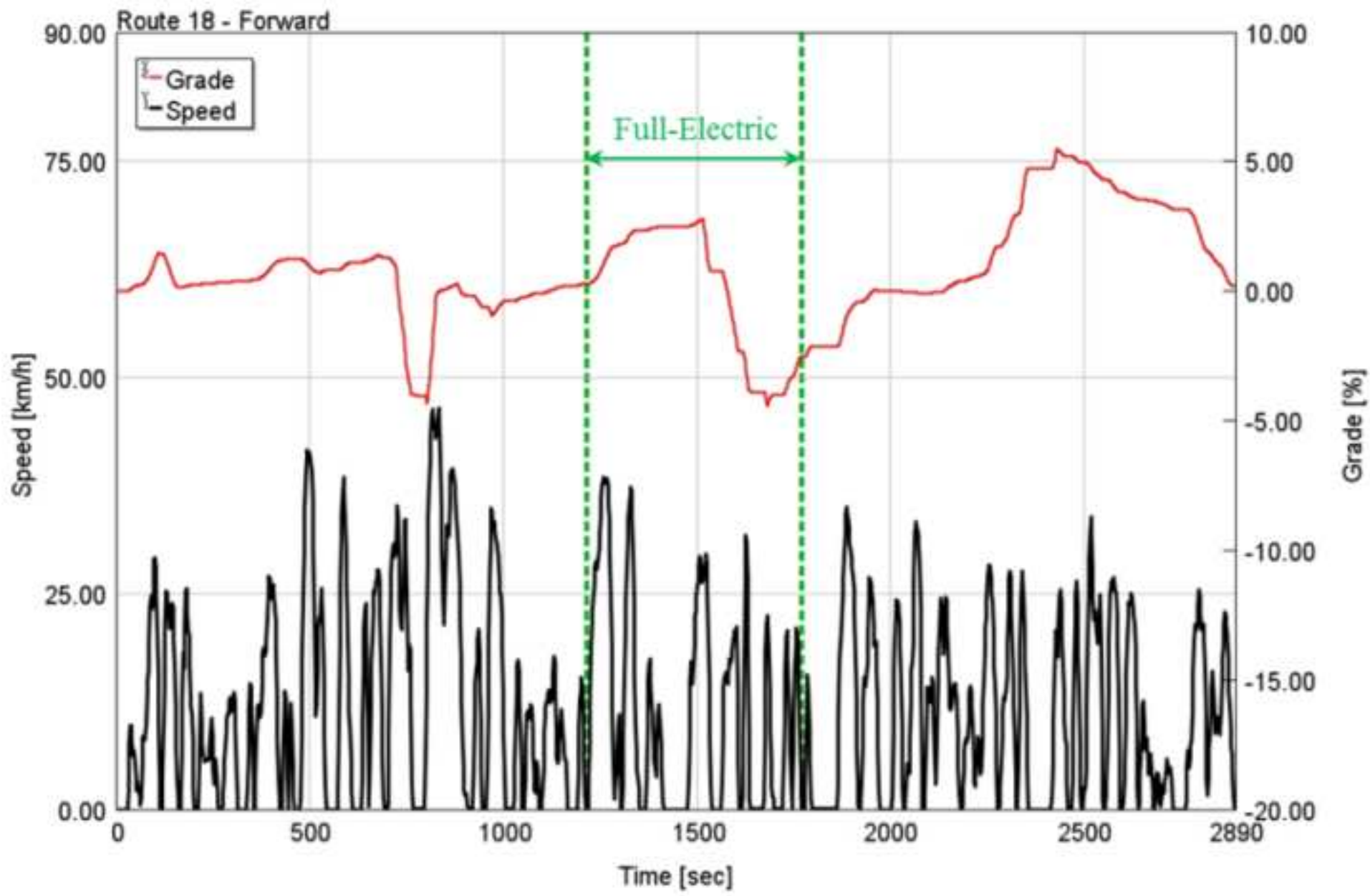

Figure5  
[Click here to download high resolution image](#)

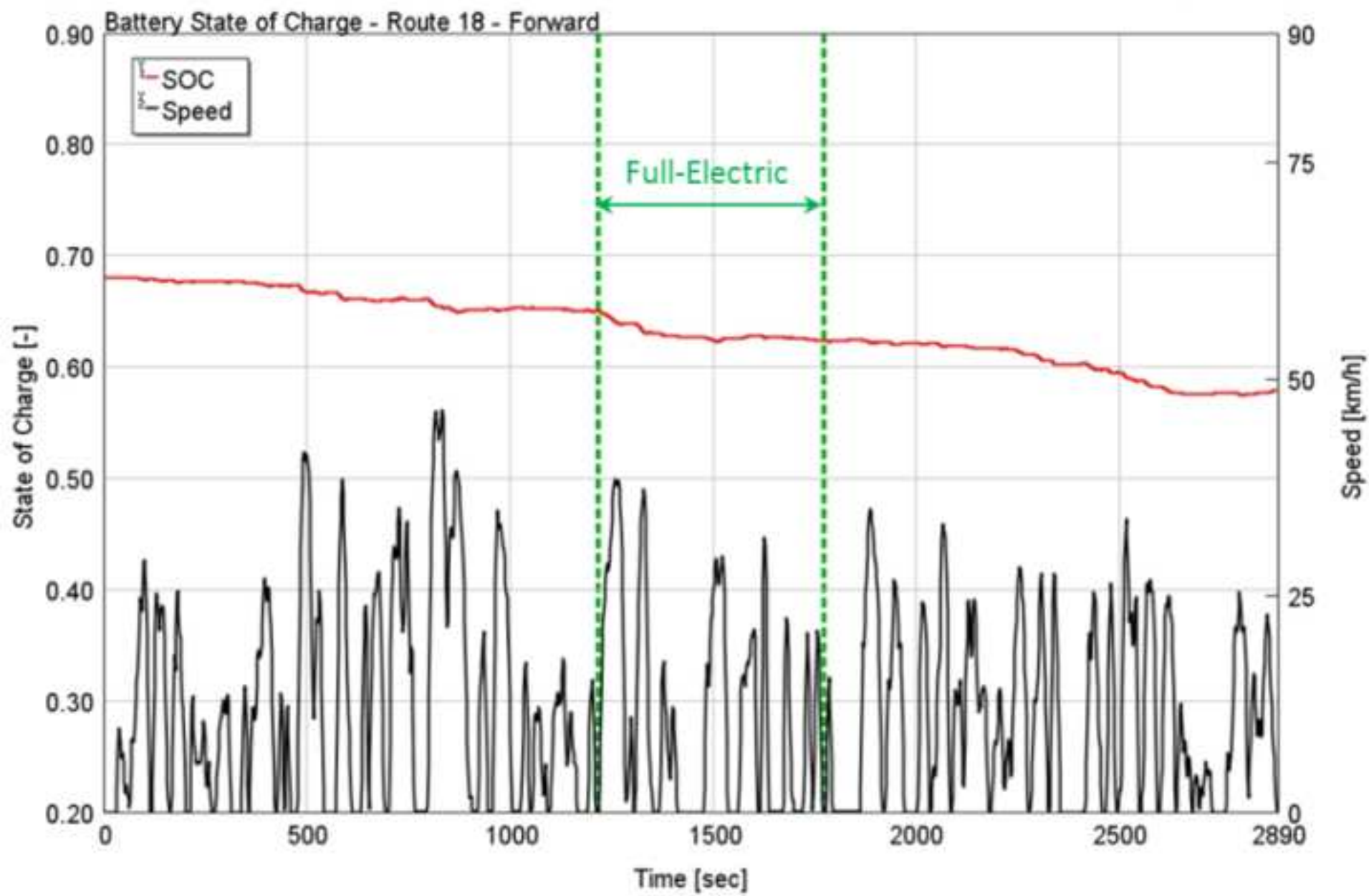

Figure6  
[Click here to download high resolution image](#)

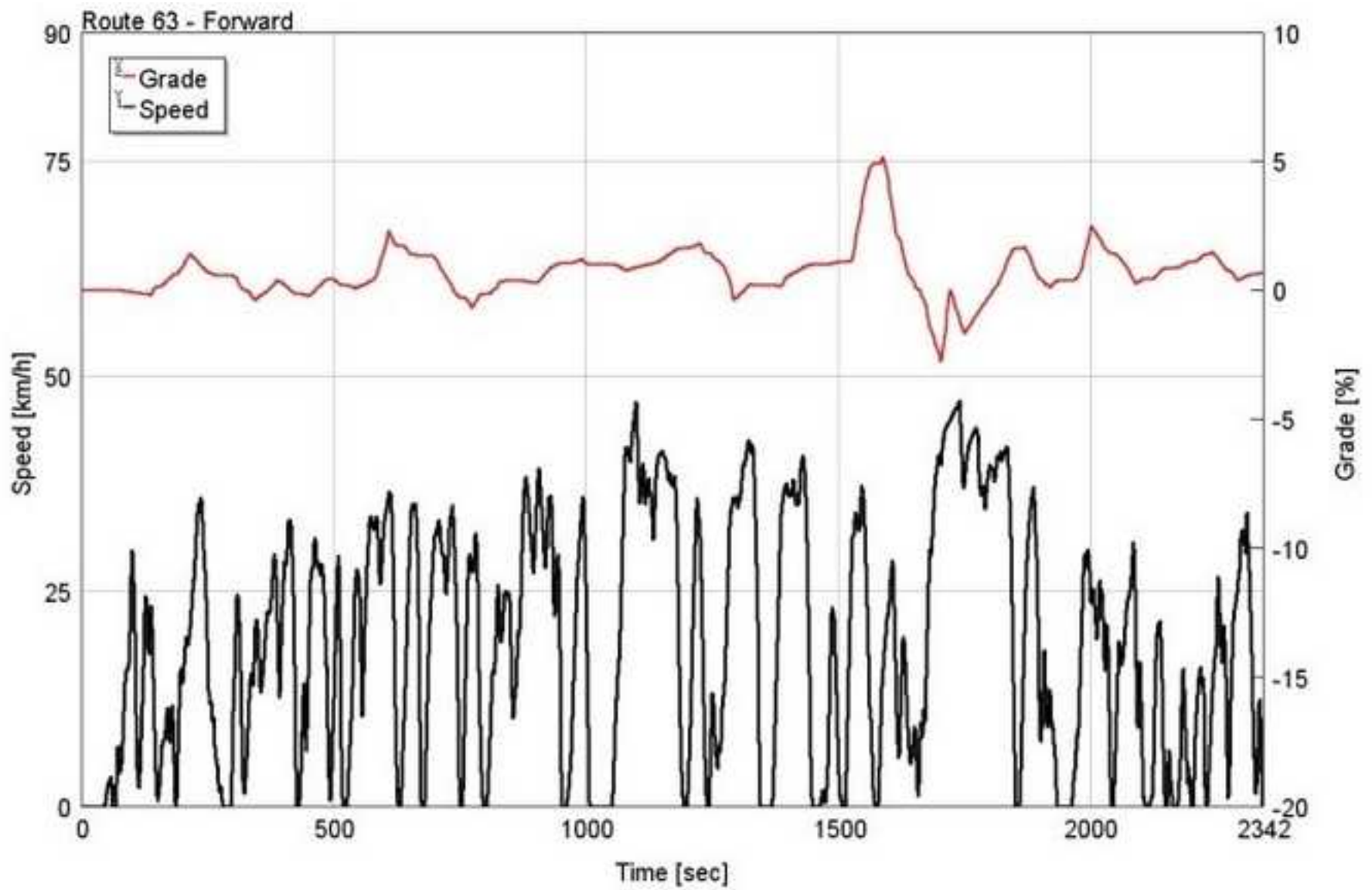

Figure7

[Click here to download high resolution image](#)

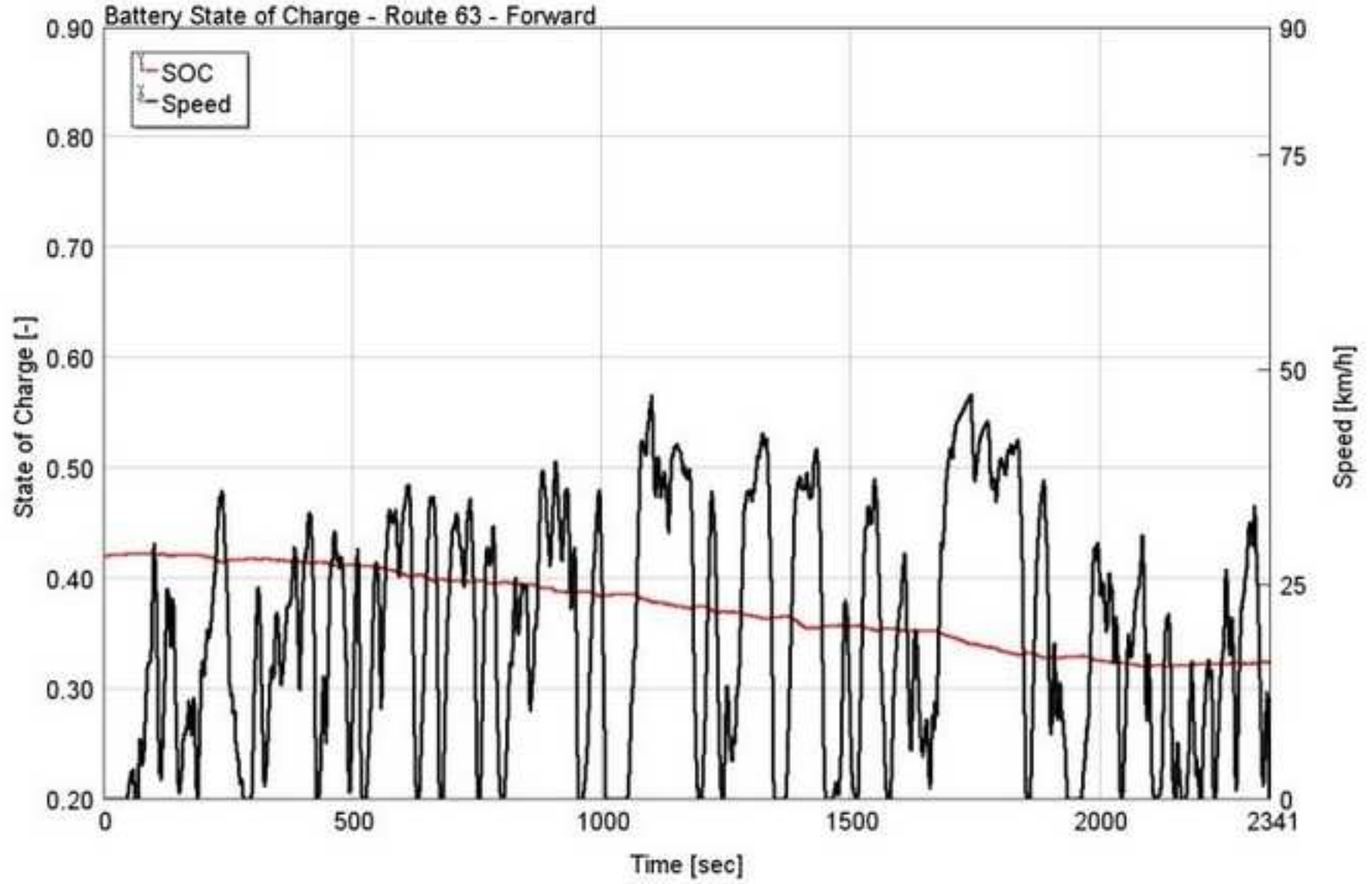

Figure8

[Click here to download high resolution image](#)

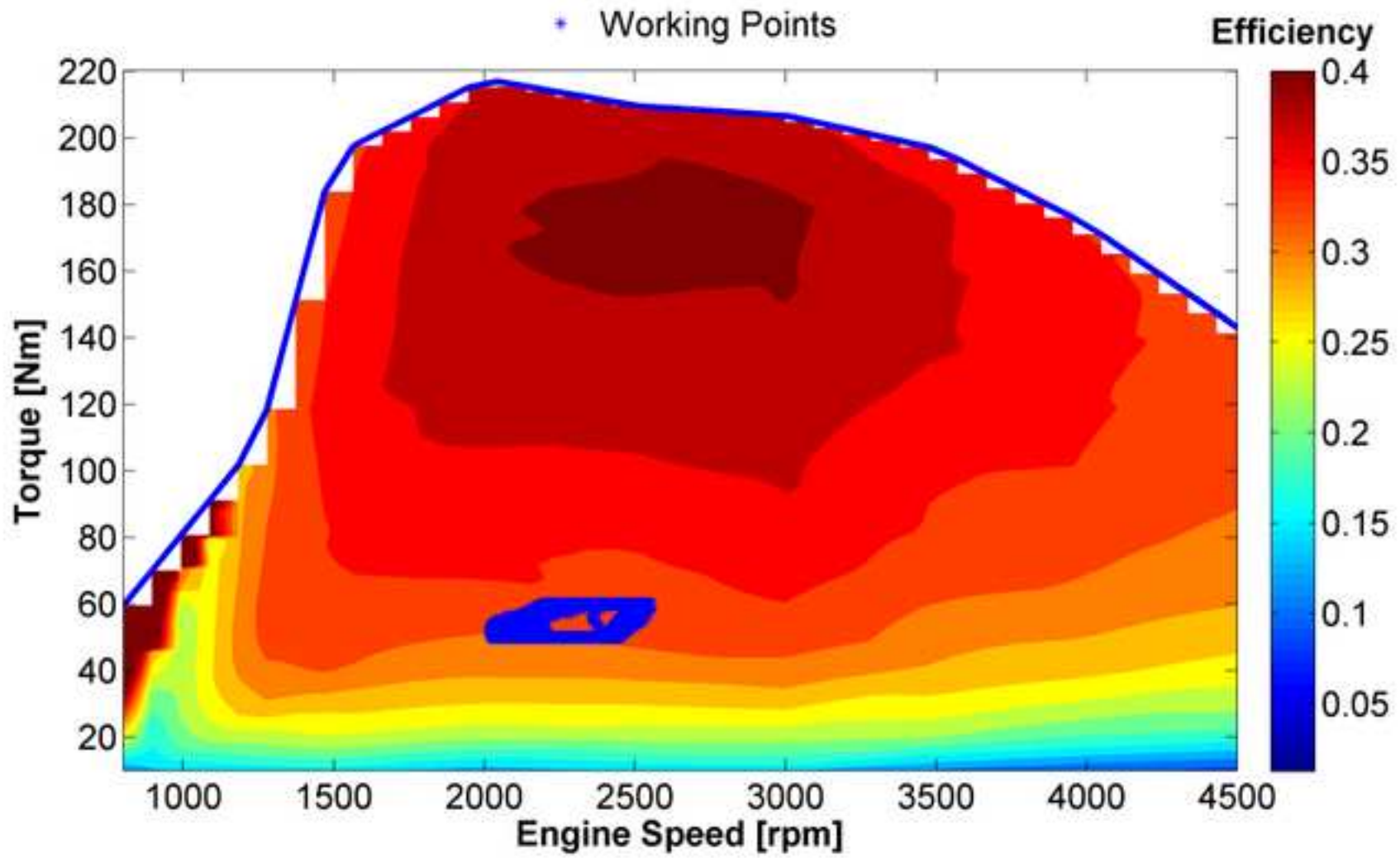

Figure9

[Click here to download high resolution image](#)

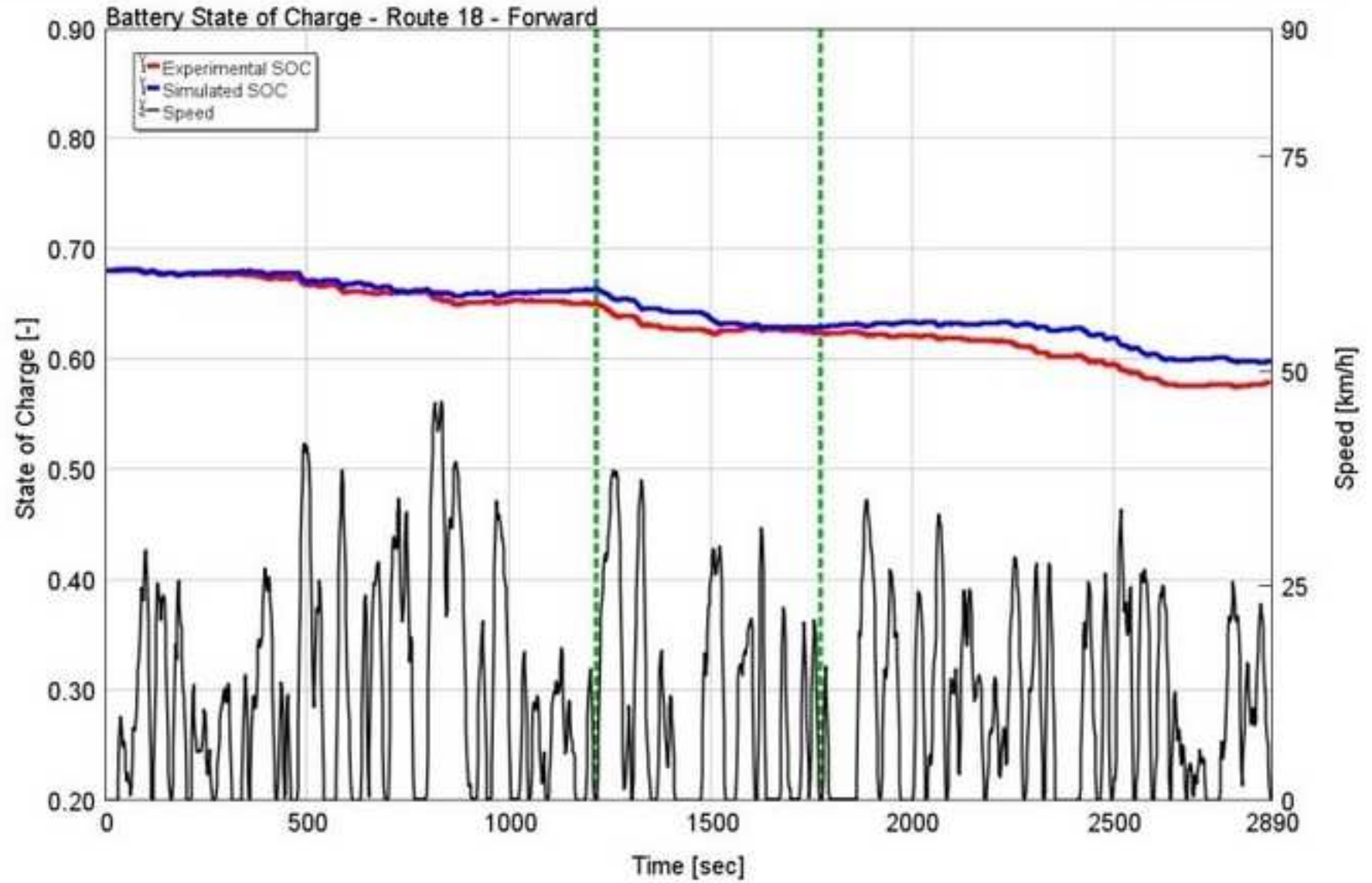

Figure10

[Click here to download high resolution image](#)

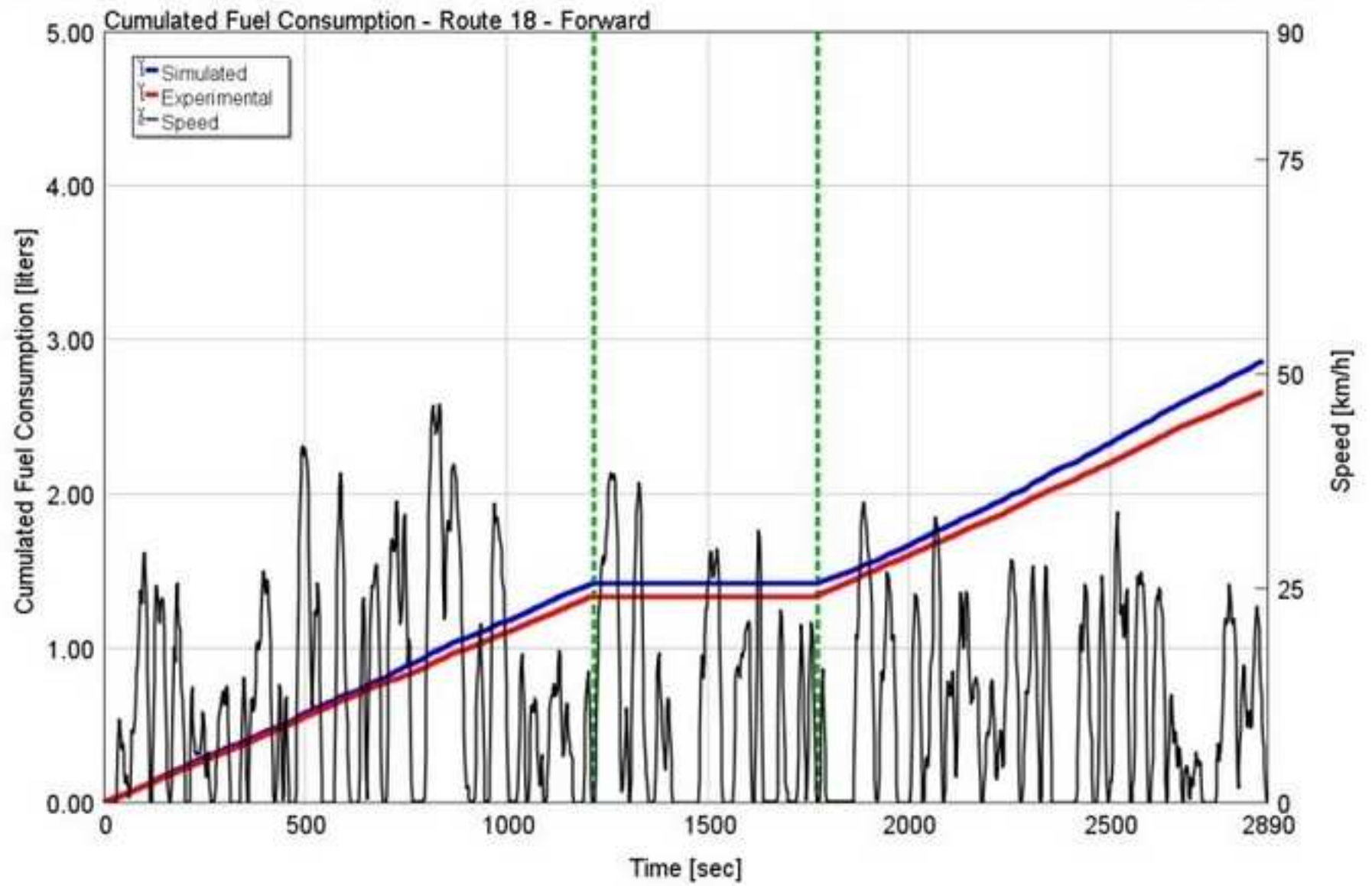

Figure11

[Click here to download high resolution image](#)

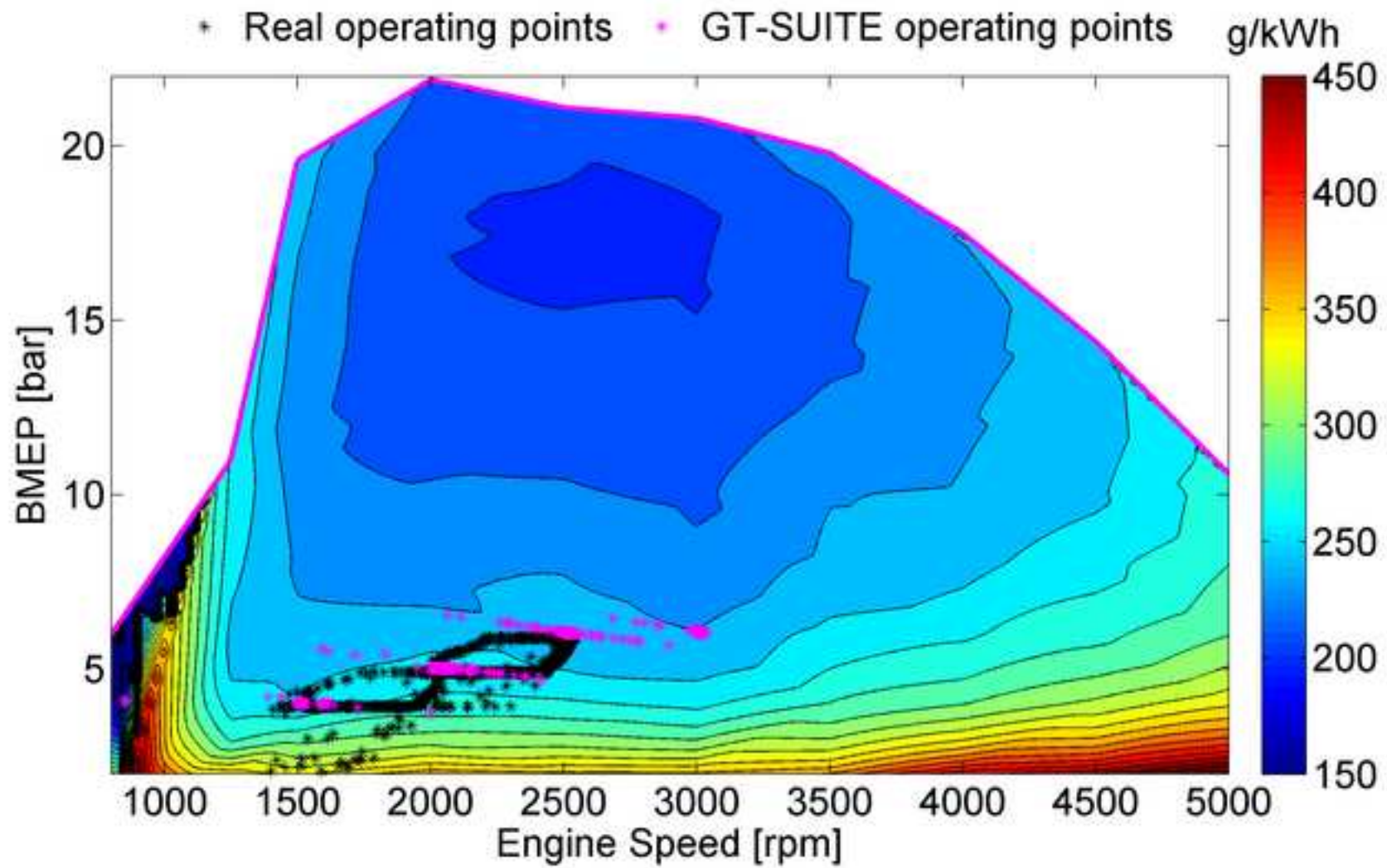

Figure12  
[Click here to download high resolution image](#)

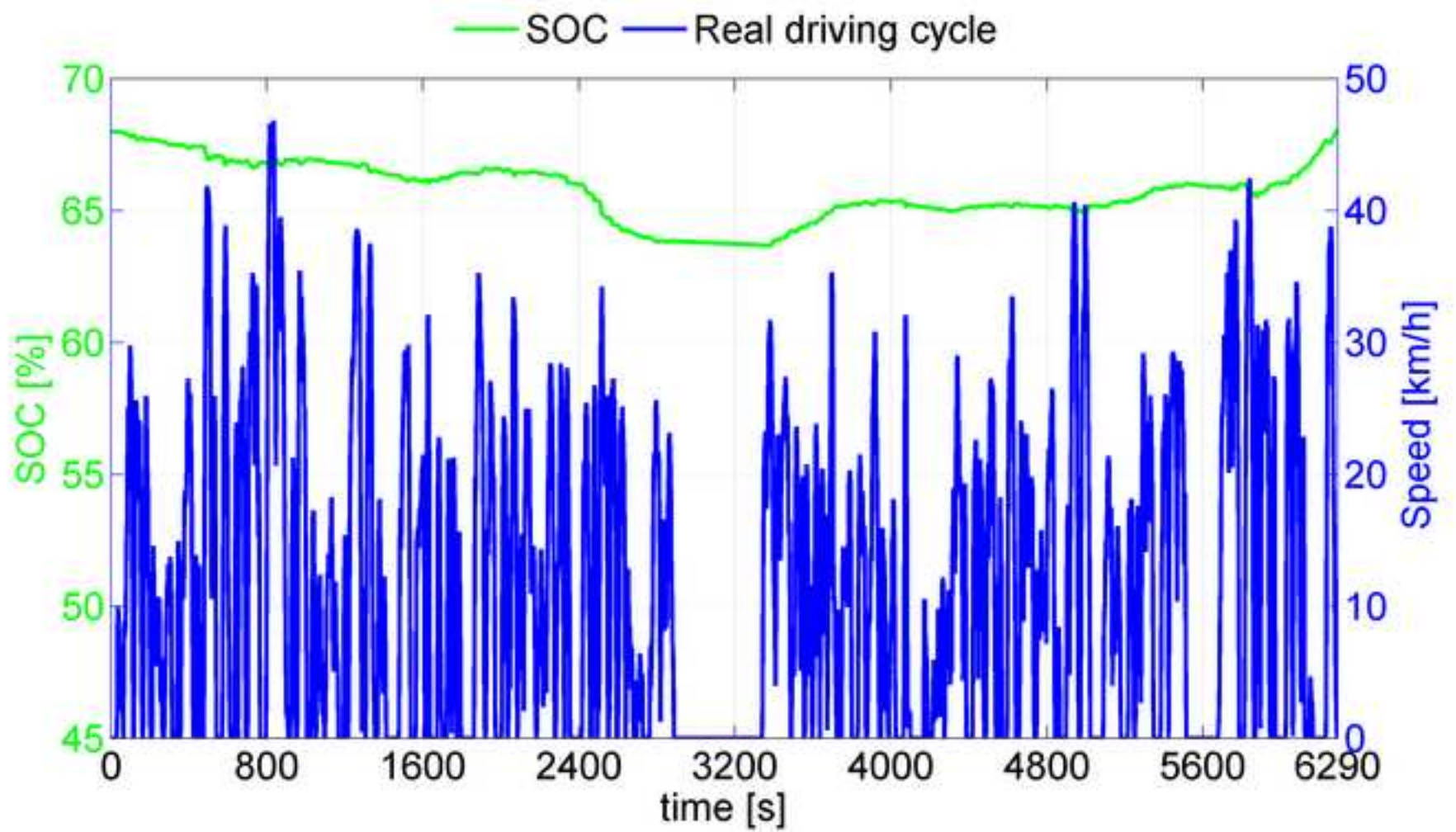

Figure13

[Click here to download high resolution image](#)

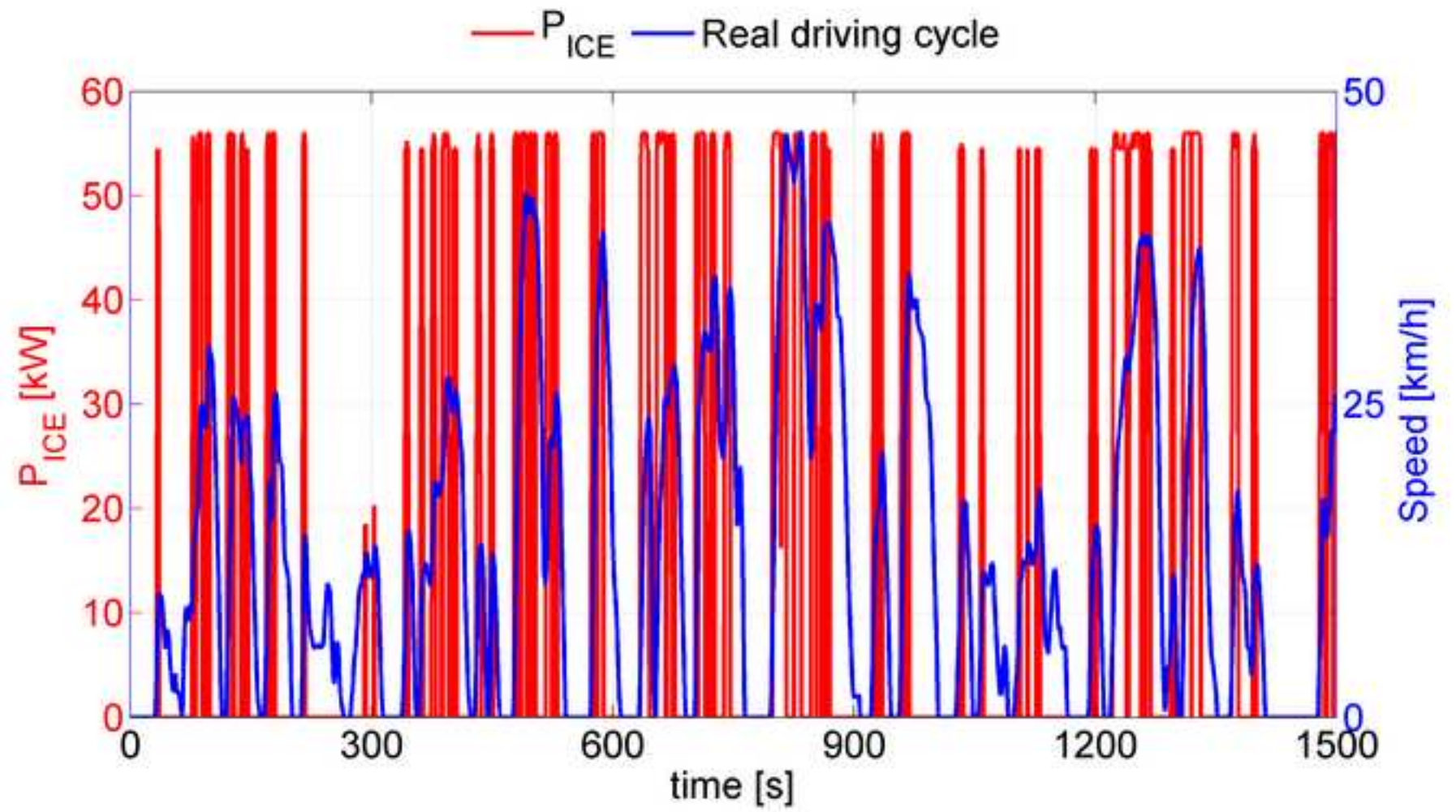

Figure14

[Click here to download high resolution image](#)

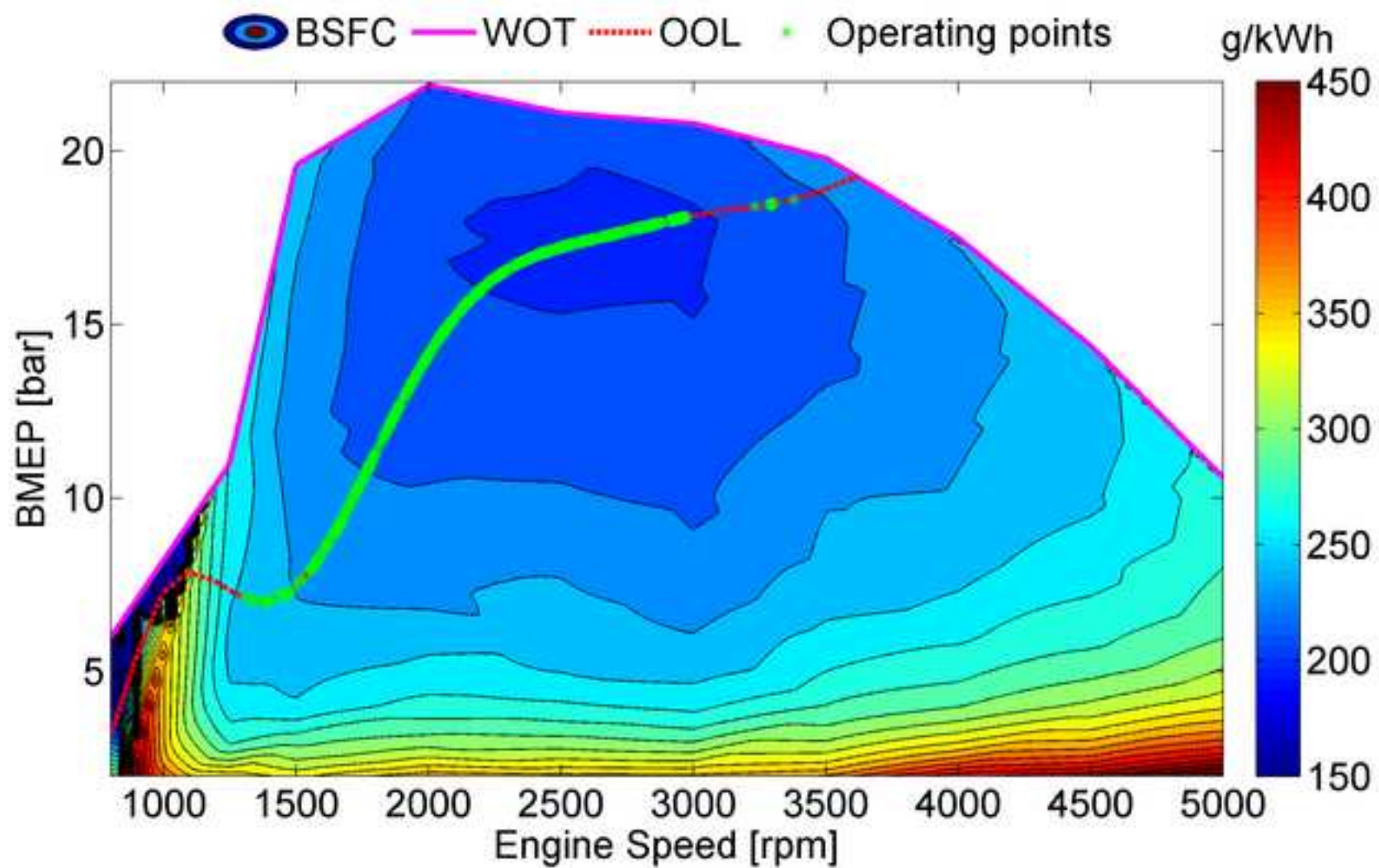

Figure15

[Click here to download high resolution image](#)

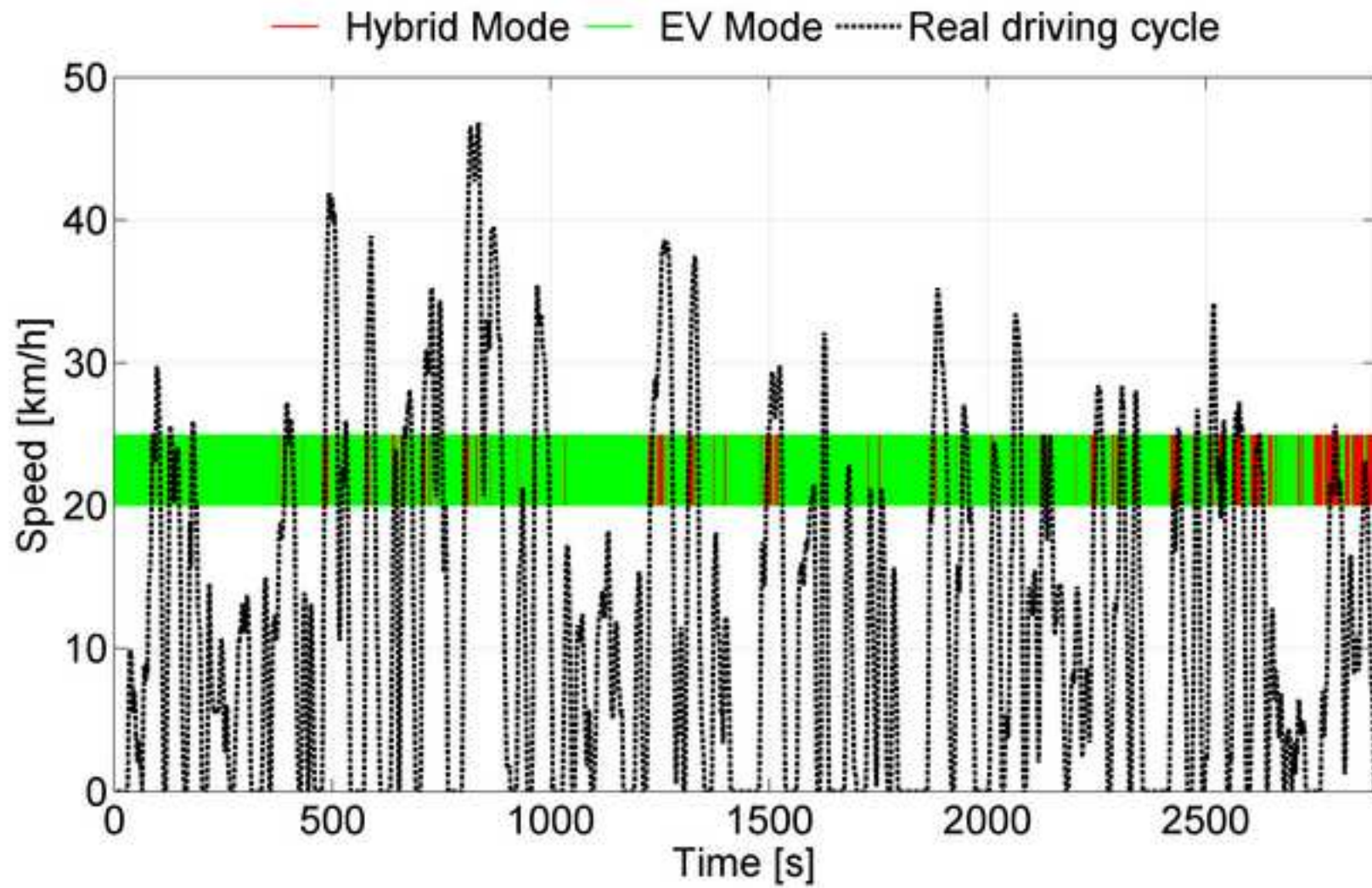

Figure16  
[Click here to download high resolution image](#)

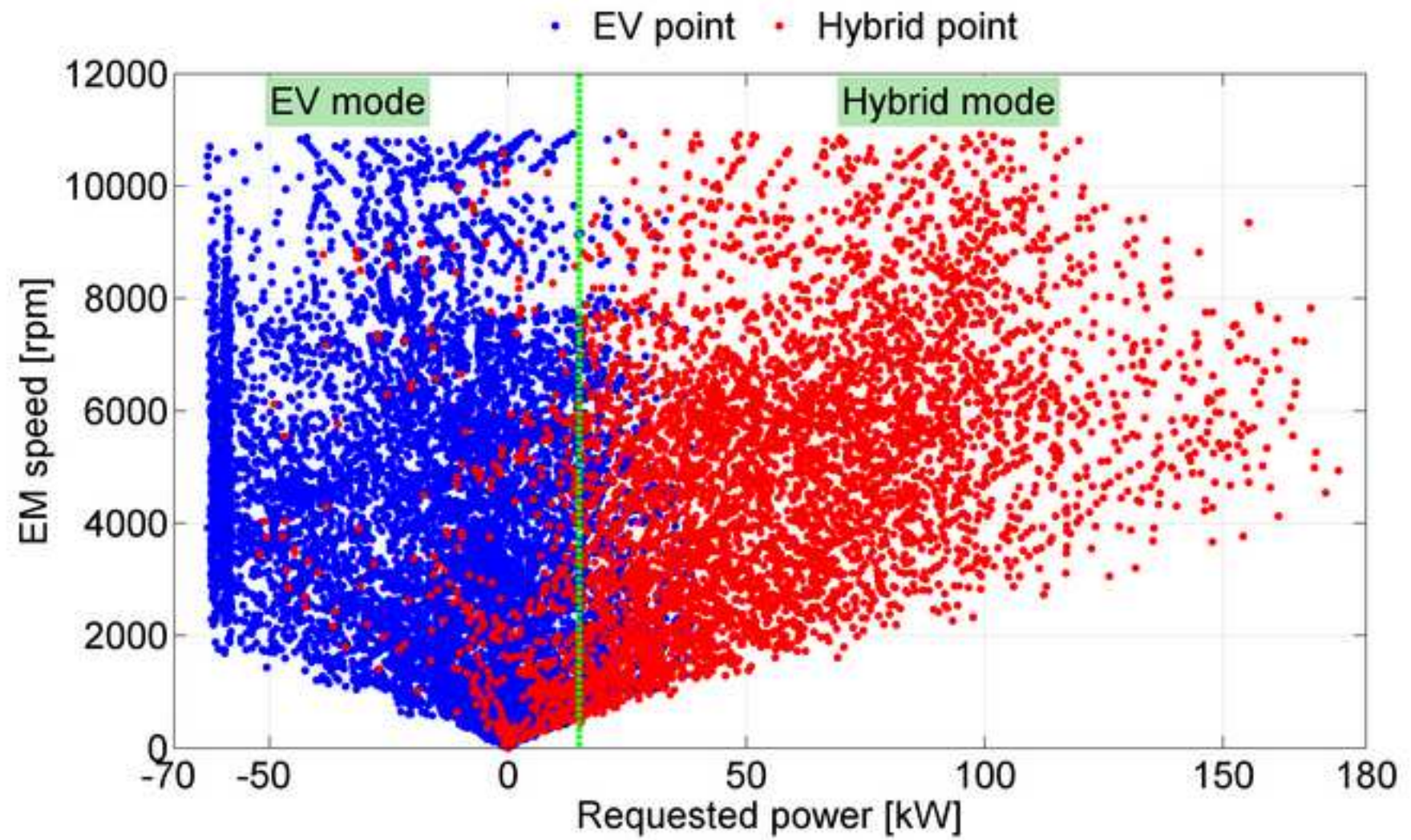

Figure17

[Click here to download high resolution image](#)

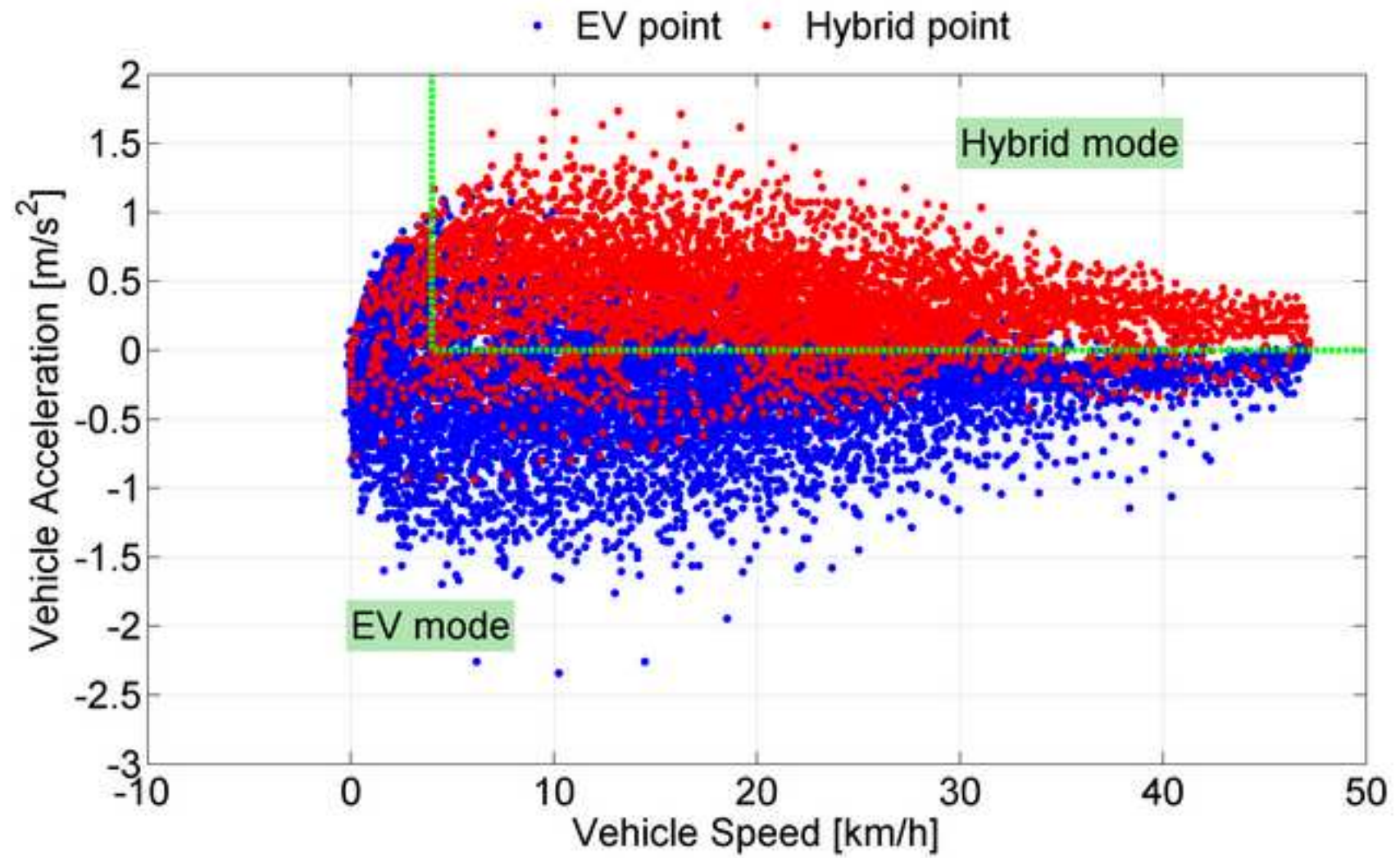

Figure18  
[Click here to download high resolution image](#)

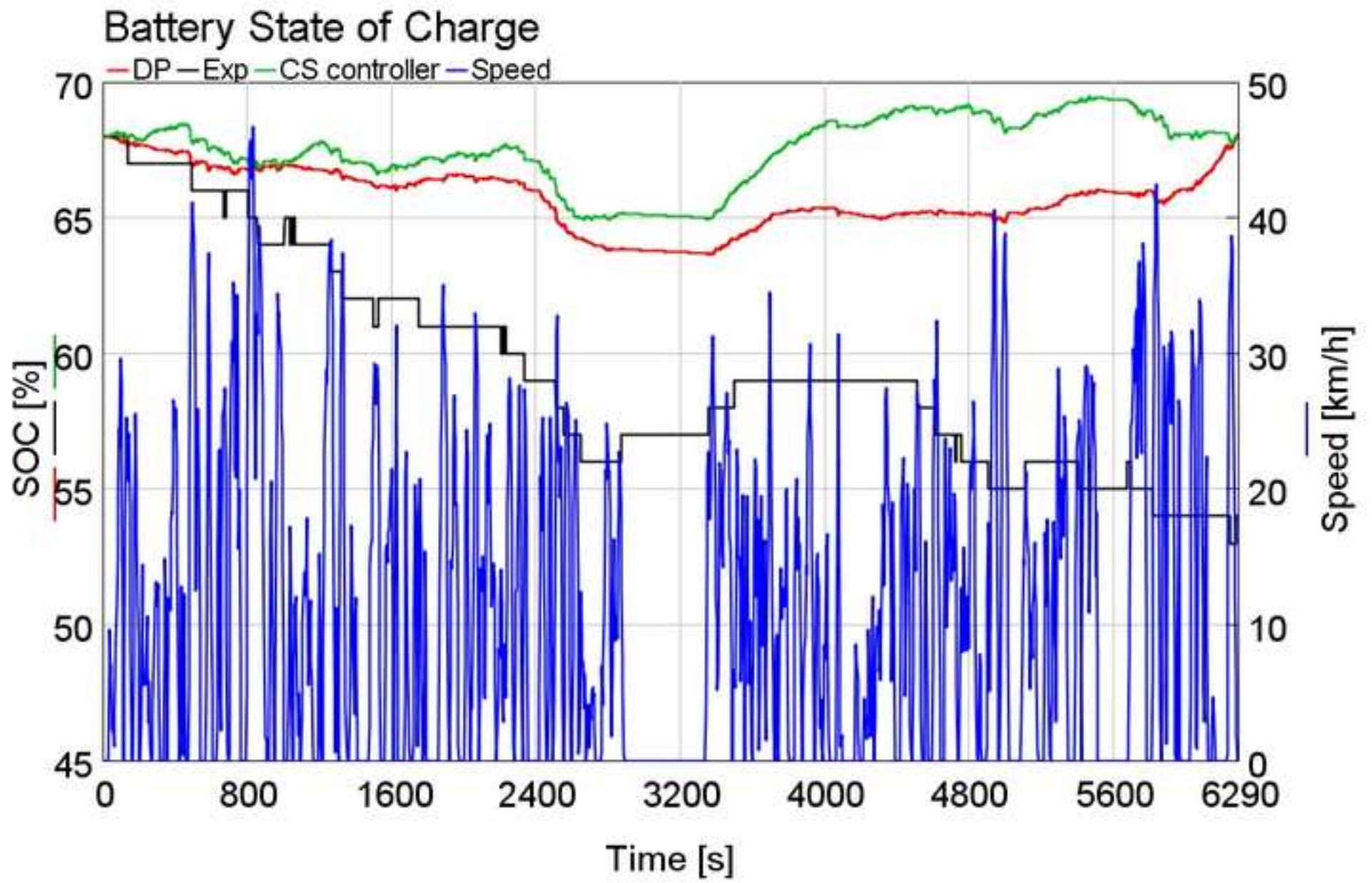

Figure19

[Click here to download high resolution image](#)

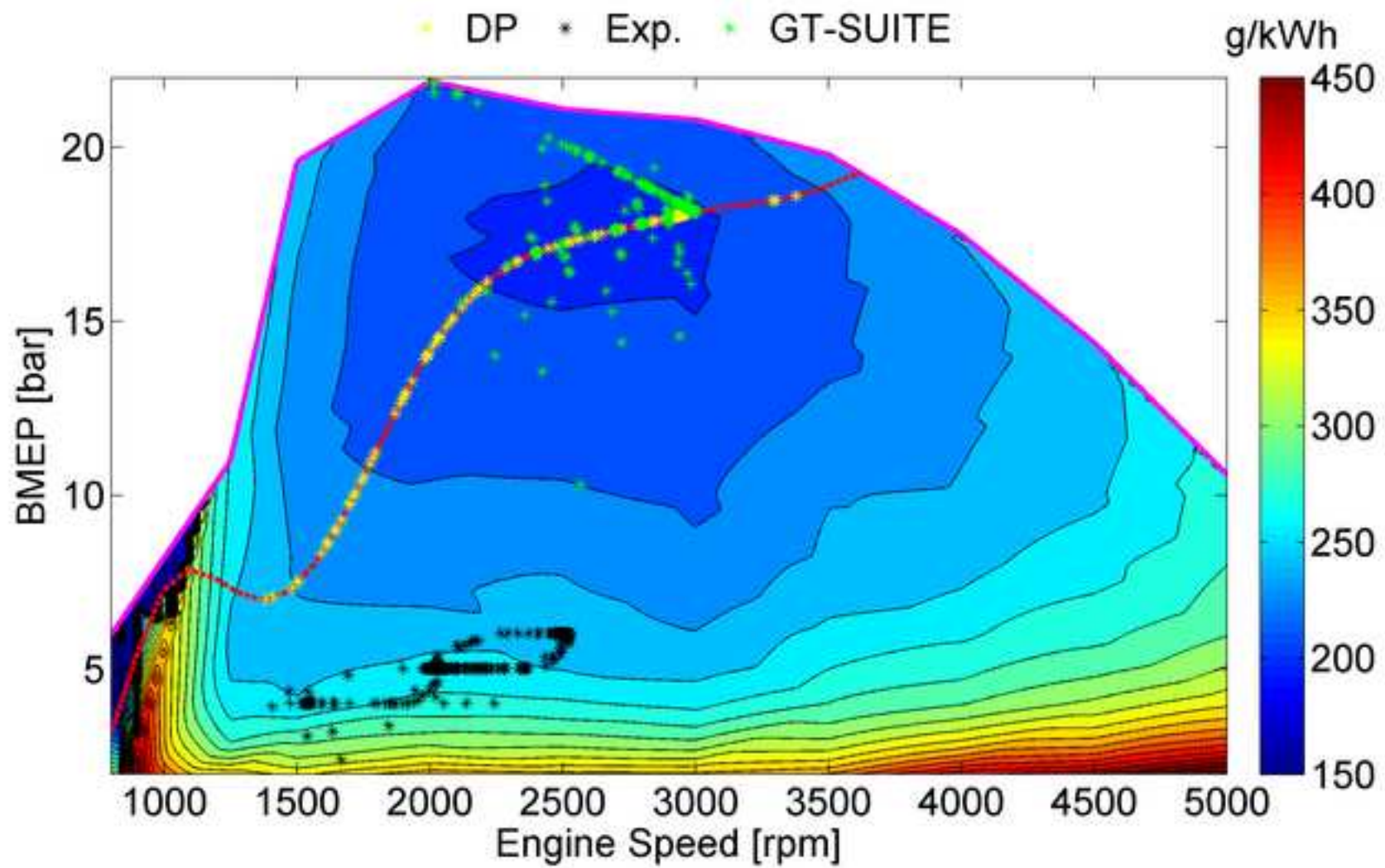

Figure20  
[Click here to download high resolution image](#)

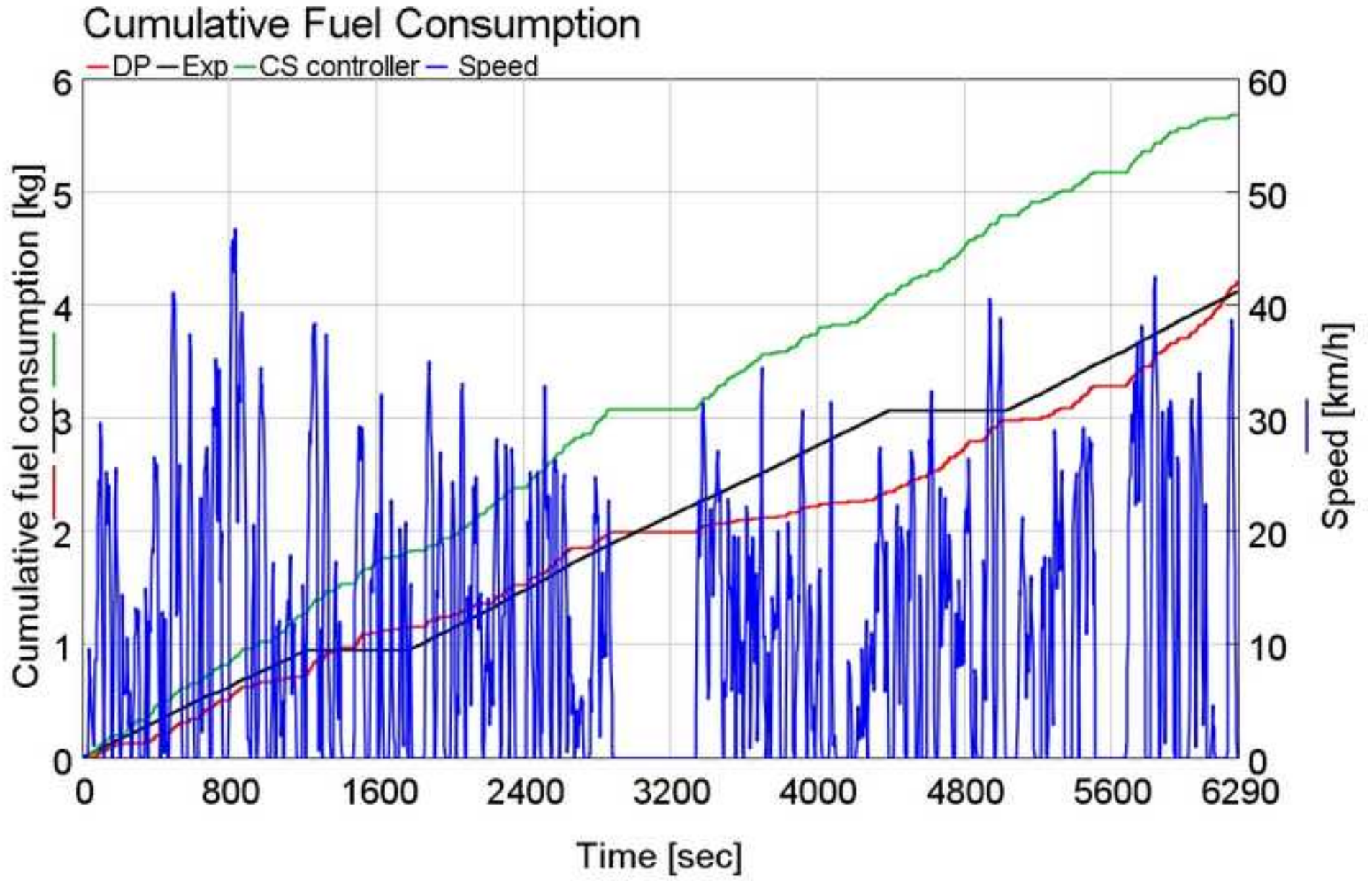

Table 1. TURBOCITY UR-GREEN data

Dimensions [mm]	12000x2500x3130 (LxWxH)
Wheelbase [mm]	6150
Wheel Track [mm]	Front 2086    Rear 1836
Curb Weight [kg]	11180
Max. Total Weight [kg]	19000
Frontal Area [m <sup>2</sup> ]	7.5
Drag Coefficient [-]	0.8
Tire Rolling Resistance [N]	$0.006+0.23 \times 10^{-6} \times V^2$ ( with V[km/h] )

**Table 1. Drivability requirements**

Max. Velocity [km/h]	65
Max. Gradeability in full-load [%]	14
Min. Acceleration [ $\text{m/s}^2$ ]	1.1

Table 3. HYBUS powertrain main specifications

Traction Motor:		
	Number [#]	2 Parallel Connected
	Type	Asynchronous
	Mass [kg]	48
	Peak Power [kW]	180
	Nominal Power [kW]	90
	Max Torque [Nm]	185
	Nominal Torque [Nm]	145
	Max. Speed [rpm]	12000
	Nominal Voltage [V]	350
	Overall Trans. Ratio ( $\omega_{wh}/\omega_{EM}$ )	1/42.5
APU		
	Generator	Traction Motor like, directly coupled to the ICE
ICE		
	Type	Diesel ( Euro 5 )
	Displacement [cm <sup>3</sup> ]	1300
	Peak Power [kW]	73
	Max Torque [Nm]	220
	Mass [kg]	236
Battery		
	Nominal Voltage [V]	384
	Maximum Voltage [V]	438
	Minimum Voltage [V]	300
	Total Capacity [Ah]	260
	Max Discharge Current (< 30s)[A]	600
	Max Discharge Current (Cont.) [A]	300
	Recommended charge current [A]	140
	Total weight [kg]	1230
	Max Output Power (kW) (< 30s)	230
	Energy [kWh]	99.84

**Table 4. Route 18 overall energy consumption data**

OVERALL CONSUMPTION	
Fuel Consumption [g/km]	258
Fuel Energy ( $m_{\text{fuel}}\text{LHV}$ ) [kWh]	58.3
Battery Consumption [kWh]	13.0
Total cost [€]	9.6

Table 5. Route 63 overall energy consumption data

OVERALL CONSUMPTION		
Fuel Consumption [g/km]		229
Fuel Energy ( $m_{\text{fuel}}\text{LHV}$ ) [kWh]		63.6
Battery Consumption [kWh]		11.3
Total cost [€]		10.00
TRANSIT AGENCY CONSUMPTION DATA		
Average Fuel Consumption [g/km]		416
Total cost [€]		14.82

Table 6. Compared “back-to-back” fuel consumption test on Route 48

FUEL CONSUMPTION		
Scania [g/km]		450
HYBUS [g/km]		330
BATTERY CONSUMPTION		
Scania [kWh]		-
HYBUS [kWh]		9.5
TOTAL COST OF THE TRIP		
Scania [€]		16.38
HYBUS [€]		13.54

**Table 7. Model validation: fuel consumption on Route 18-forward**

TOTAL FUEL CONSUMPTION	
Experimental [liters]	2.7
Simulated [liters]	2.8

**Table 8. Braunschweig cycle simulation: fuel consumption results compared with experimental results for an EEV Irisbus**

FUEL CONSUMPTION		
Irisbus [g/km]		340
Irisbus fuel energy ( $m_{\text{fuel}}\text{LHV}$ ) [kWh]		43.8
HYBUS [g/km]		182
HYBUS fuel energy ( $m_{\text{fuel}}\text{LHV}$ ) [kWh]		23.5
BATTERY CONSUMPTION		
Irisbus [kWh]		-
HYBUS [kWh]		10
TOTAL COST OF THE TRIP		
Irisbus [€]		5.64
HYBUS [€]		3.09

**Table 9. Fuel consumption and cost over the real driving cycle**

	Fuel (L)	Cost (€)
HYBUS Real test (Charge depleting)	Fuel: 4.83 L Electric Energy: 14 kWh	8.55
HYBUS DP (Charge sustaining)	4.93	6.44
HYBUS novel controller (Charge sustaining)	6.65	8.69
Conventional bus	9.32	12.18

# 1 Development of a new hybrid bus for urban public 2 transportation

3  
4  
5 **Federico Millo, Luciano Rolando, Rocco Fuso, Jianning Zhao**

6 Energy Department,

7 Politecnico di Torino,

8 c.so Duca degli Abruzzi, 24

9 10129 Torino - ITALY

10 E-mail: federico.millo@polito.it

11 E-mail: luciano.rolando@polito.it

12 E-mail: rocco.fuso@polito.it

13 E-mail: jianning.zhao@polito.it

## 14 15 16 17 **Abstract**

18 Nowadays the increasing demand for sustainable mobility has fostered the  
19 introduction of innovative propulsion systems also in the public transport sector in  
20 order to achieve a significant reduction of pollutant emissions in highly congested  
21 urban areas. This paper describes both the design and the optimization of an  
22 environmentally friendly hybrid bus (hereafter referred to as “HYBUS”) for urban  
23 public transportation.

24 After a preliminary description of the main features of the hybrid architecture, this  
25 paper assessed, through numerical simulations, the fuel economy potential of the  
26 hybridization in real world driving conditions. The promising results of this first part  
27 of the study led to the development of a first prototype.

28 The first prototype of the bus was built by integrating an innovative hybrid  
29 propulsion system featuring a plug-in series architecture into the chassis of an old  
30 IVECO 490 TURBOCITY. The bus is 12 meters long and capable to host up to 116  
31 passengers in the original layout. The project relied on a modular approach where  
32 the powertrain could be easily customized for size and power, depending on the  
33 specific application.

34 The prototype was then extensively tested in the city of Genoa, Italy, an urban  
35 context extremely challenging for a hybrid powertrain due to its frequent uphill  
36 routes and significant road grades. The outcomes of the test campaign confirmed  
37 the simulations forecasts, and fostered additional analysis aimed to optimize the  
38 energy management strategy of the hybrid powertrain.

39 Numerical simulations were then used in order to identify more refined energy  
40 management strategies capable of further enhancing the fuel economy potential of  
41 the hybrid architecture. Consequently, a novel energy management was  
42 developed, and virtually tested, to manage the HYBUS in a more effective way.  
43 The results demonstrated the interesting potential of such hybrid architecture.

#### 44 **Keywords**

45 Hybrid Electric Bus; CO<sub>2</sub> Emissions; Energy Cost.

### 46 **1. Introduction**

47 In a context of the global economic downturn, the high demand for sustainable  
48 transportation and for cost reduction for transit agencies could meet halfway.  
49 Indeed, fuel cost represents one of the most significant portions of transit agency  
50 budgets (by way of example for the 2012 for the Turin Transit Agency fuel cost was  
51 equal to 22% of sales proceeds [1]) and its reduction directly corresponds to a cut  
52 of CO<sub>2</sub> emissions. As a consequence, bus hybridization offers an attractive option  
53 in this direction and has the potential to significantly reduce operating costs for  
54 agencies.

55 Simulation tests have highlighted the strong capabilities that different hybrid bus  
56 concepts can exploit in terms of better fuel economy [2-4] and lower emissions  
57 compared to conventional buses equipped with Internal Combustion Engines  
58 (ICEs).

59 Although the best enhancement in terms of fuel consumption is usually reached by  
60 means of powertrain architectures with high flexibility like Hybrid Electric Vehicles  
61 (HEVs), to date HEVs had not been widely adopted due to their high costs related  
62 mainly to the battery pack. Therefore, sometimes low cost hybridization solutions  
63 such as for instance Hybrid Hydraulic Vehicles (HHVs), seem to be more attractive

64 even if they exhibit lower efficiency compared to equivalent electrified powertrains  
65 [5].

66 However, the amount of case-studies focused on hybrid buses and their  
67 experimental testing which is available in literature is still limited, although in the  
68 last few years it is possible to cite several examples of agencies that are currently  
69 employing experimental HEV buses in their fleets [6-11] to assess their real  
70 performance. Moreover, fuel economy can vary according to a huge number of  
71 factors, including number of stops per unit distance, road grade, surrounding traffic  
72 volume and conditions, environmental conditions, driving style, type of hybrid  
73 technology, roadway type, and passenger load [12-14].

74 For these reasons the real fuel economy gain which can be gathered during in-use  
75 vehicle operation sometimes leads to results which are very different from those  
76 expected.

77 Finally, it has to be mentioned that an additional barrier to the wider diffusion of  
78 hybrid electric buses is represented by their significantly higher purchase cost  
79 (approximately 50% to 70% higher) [15] in comparison with conventional diesel  
80 urban buses.

81 The HYbrid BUS (HYBUS) project, carried out in cooperation between Politecnico  
82 di Torino and Pininfarina, Italy, aims therefore to address the abovementioned  
83 issues, trying to reduce both the fuel consumption and the purchase cost of a new,  
84 environmentally friendly urban bus, which has been conceived through the study of  
85 a modular hybrid propulsion system, allowing the conversion of old vehicles  
86 currently equipped with Euro 0–1–2 diesel engines into buses with serial hybrid  
87 power packs.

88 The core idea of the project is to exploit the older buses present in the agencies'  
89 fleets, which can be still fully functional, but with pollutant emission rates too high  
90 to comply with current legal limitations: in the HYBUS the original diesel powertrain  
91 of an old IVECO 490 TURBOCITY (12 mt. long, 116 passengers urban bus) was  
92 removed and replaced by a new generation plug-in series hybrid powertrain.  
93 Moreover, thanks to the modularity of the proposed hybrid architecture, the  
94 powertrain could be adapted to different types of urban busses.

95 The cost saving is estimated to be about 50% compared to a new conventional  
96 diesel bus (for which a price estimate between 220-290 k€ can be made[16-17])  
97 and about 60% compared to a new hybrid bus (for which a price estimate of about  
98 350 k€ can be made [18-19]).

99 Such an approach could obviously not be considered the ultimate solution towards  
100 the green urban mobility: however, although a retrofitted bus, will not last as long  
101 as a new hybrid bus, with its upfront savings compared to a factory-new solution, it  
102 could pave the way to a fast upgrade of the fleets, allowing a gradual and  
103 affordable introduction of new advanced HEVs.

104 This article describes in the next Section 2 the steps that led to the HYBUS  
105 prototype production, from the concept idea to the design and manufacturing, as  
106 well as the first testing phases under real world operating conditions in the city of  
107 Genoa, Italy. Afterwards, in Section 3 the set-up, validation and exploitation of a  
108 numerical model of the HYBUS is described, in order to assess the potential of the  
109 selected hybrid powertrain in terms of fuel economy and to provide a virtual test rig  
110 for the development of more advanced energy management strategies, which are  
111 discussed in the last Section 4.

## 112 **2. HYBUS Development and Experimental Assessment**

### 113 **2.1. Powertrain Requirement Evaluation**

114 The revamping of a bus, with the goal to realize a completely new powertrain,  
115 requires the knowledge of the typical mission profile and of the main features of the  
116 vehicle.

117 For these reasons the first step of the project was the identification of a bus  
118 potentially suitable for the task. After a brief research among the Turin transit  
119 agency's fleet [20], the IVECO TURBOCITY UR-GREEN – EURO 1 was selected  
120 since it represented the largest fraction of the older buses in the agency's fleet, and  
121 by upgrading this model alone, more than 10% of overall vehicles of the Turin  
122 transit agency [21] could reduce their environmental impact in the city center.

123 The main features of the vehicle are summarized in Table 1.

124 As far as the driving pattern is concerned, the Standardized On-Road Test Cycles  
125 (SORT) 1 (Heavy Urban) and SORT 2 (Easy Urban) cycles [22] were initially used  
126 to obtain, through a simple kinematic model [23], a first estimate of the vehicle road  
127 load during typical operating conditions.

128 Although traction power peaks during the abovementioned test cycles can be  
129 larger than 150 and 200 kW, the average traction power levels do not exceed 6  
130 and 10 kW, respectively on SORT1 and SORT2 [2].

131 Benchmarking analysis on other buses of the same category led to set the  
132 additional quantitative targets which are reported in Table 2.

133

## 134 **2.2. Main HYBUS Characteristics**

135 A series hybrid architecture was chosen in order to allow the revamping of the  
136 vehicles independently from the characteristics of the buses owned by the transit  
137 agencies. Indeed, owing to the different layouts of the engine compartment, a  
138 different placement of the equipment could be necessary to satisfy requirements  
139 such as cooling, fuel supply, and safety without major modifications of the original  
140 chassis. From this point of view, a series hybrid powertrain is extremely flexible:  
141 the only constraints are the connection of the electric traction motor with the  
142 vehicle transmission and a mechanical connection between the internal  
143 combustion engine and the electric generator to realize the Auxiliary Power Unit  
144 (APU). All the other power links, being electrical, can be tailored for the specific  
145 application. A scheme of the connections between the main hybrid powertrain  
146 components is shown in Figure 1.

147 To achieve the objectives of modularity and easiness of updating, the main  
148 components of the powertrain were placed within aluminum frame structures, with  
149 anchorage points that can be adapted to different types of vehicles. Within each  
150 structure each component can be fixed by standardized brackets allowing an easy  
151 maintenance.

152 Once the power/energy requests and the additional drivability specifications were  
153 evaluated, as described in previous section 2.1, the components and the main  
154 features of the vehicle powertrain were selected (Table 3).

155 Considering a typical urban daily mission profile, an average energy requirement of  
156 about 5 MJ/km was estimated [24]; consequently, a battery pack of about 100 kWh  
157 was chosen to avoid excessively “deep” discharges (design specifications of the  
158 battery allow a peak discharge current of 600 A for at most 30 seconds) that could  
159 dramatically reduce battery life. Indeed, such a capacity allows the possibility to run  
160 on several routes before to recharge the plug-in vehicle at the bus end of line.

161 For the battery modules a Lithium Iron Magnesium Phosphate technology was  
162 chosen as the most suitable for this type of application. This technology chimes  
163 with the automotive requirements for a battery [25]. Among the benefits, are worth  
164 to be noted the high number of recharging cycles with deep discharge allowed  
165 during the battery life; a naturally good “thermal management”, reducing the on-  
166 board cooling requirements; extremely low self-discharge rate, limiting battery  
167 depletion after several days of stop; fast and safe recharging capabilities. An  
168 overall sketch of the system is depicted in Figure 2, where the main powertrain  
169 components are highlighted in blue.

170 As far as the choice of the ICE is concerned, a specific study to identify the best  
171 trade-off between fuel consumption, pollutant emissions and engine size was  
172 carried out [2],[26]. Since in a series hybrid architecture the internal combustion  
173 engine has only to provide the average power requested by the vehicle, a small  
174 displacement automotive ICE (1.3 liter) was selected, in order to fully exploit the  
175 potential offered by engine downsizing.

### 176 **2.3. Testing Activities**

177 After the preliminary evaluations carried out through numerical simulation, the first  
178 HYBUS prototype was built in the Pininfarina facilities (see Figure 3) and the real  
179 potential of the HYBUS architecture in terms of fuel economy was then verified with  
180 an extensive test campaign on the routes of the Italian city of Genoa, in  
181 cooperation with the local transit agency. The city is composed of a thin coastal  
182 strip behind which hills and mountains rise: this peculiar geography produced  
183 highly heterogeneous city roads, going from flat sections to steep climbs with  
184 grades up to 15 %. Consequently the daily routes of the local buses represent a  
185 quite challenging test for a series hybrid powertrain as well as for its energy  
186 management strategy.

187 Among these urban routes several were tested with the vehicle fully ballasted and  
188 in the following sections some brief excerpt of the most meaningful tests will be  
189 analyzed.

190 It is worth to be mentioned that these experimental tests were the first on-road  
191 experiences of the HYBUS prototype. Therefore the VMU (Vehicle Management  
192 Unit) dataset's variables were precautionary limited to avoid any reliability issue,  
193 limiting for instance the maximum vehicle speed at 50 km/h.

194

### 195 ***Pure Urban - Route 18***

196 Route 18 is representative of the usage in a pure urban context: traveling through  
197 the most congested streets of the city (with an average speed of about 11km/h on  
198 its 9.4 km of length and a variable grade between  $\pm 5\%$ ), with a lot of stops at  
199 traffic lights and continuous bus stops due to the high number of passengers  
200 (about 3.5 stops/km on average), this usage undoubtedly represents a challenging  
201 benchmark for conventional buses. The energy requirement of 2.75 MJ/km on this  
202 route confirms the conservative assumption made in paragraph 2.2. Besides the  
203 severe gradeability requirements, an increased power absorption from the  
204 ancillaries systems has also to be taken into account, due to the continuous usage  
205 of brakes and doors openings (which are pneumatically assisted), leading to an  
206 intensive activity of the air compressor.

207 One of the real mission profiles acquired during the experimental activity is shown  
208 in Figure 4. A restricted traffic area was also considered during the trip, switching-  
209 on the pure electric propulsion. The SOC depleting resulting from the trip is shown  
210 in Figure 5.

211 Taking into account both the forward and backward travel, and adopting the prices  
212 paid by the transit agency for electricity (0.16 €/kWh) and for diesel fuel (1.31 €/l) at  
213 time when tests were carried out (June 2012), the overall energy consumption data  
214 of the HYBUS are summarized in Table 4. In particular the vehicle exploited 13  
215 kWh of energy from the battery and a fuel consumption of 258 g/km from the ICE.  
216 Unfortunately the real fuel consumption data of the conventional buses on this  
217 route were not available, but considering the average mileage value of 1.5 km/l  
218 registered by Genoa transit agency, the total cost for each complete round trip on

219 route 18 for a conventional diesel bus will lead to more than 16 €, highlighting the  
220 impressive savings of the HYBUS.

### 221 ***Urban & Suburban Mix - Route 63***

222 After the urban tests previously described, an urban & suburban mix was tested on  
223 Route 63, which is representative of a commuter usage, with two urban sections  
224 connected by a central suburban piece. The total length of the round trip is about  
225 23.3 kilometers, with an average speed of about 19 km/h, and the grade profile  
226 (with a peak of 5%), together with a real speed profile, is depicted in Figure 6. The  
227 SOC depleting resulting from the trip is shown in Figure 7.

228 Also in this case the fuel and cost savings achieved by the HYBUS in comparison  
229 with a conventional bus (data provided by Genoa transit agency) were impressive,  
230 as shown in Table 5. In this case an average fuel consumption of 229 g/km was  
231 obtained by the HYBUS and 11.3 kWh were drawn from the battery.

232 These results are even more impressive when considering that the APU working  
233 points were kept, as a precautionary measure, in the lower part of the engine map,  
234 as shown in Figure 8, in order to avoid excessive stresses on the engine and on its  
235 cooling system, due to the high environmental temperatures (test were carried out  
236 during the month of July).

237 Therefore the efficiency of the APU could be further improved in the next version of  
238 vehicle, leading to an extra reduction of the fuel consumption. For these reasons  
239 further numerical simulations were performed in the following to evaluate the  
240 improvements that could be obtained with a refined energy management system  
241 without precautionary limits on the APU operation.

### 242 ***Compared “back-to-back” fuel consumption test***

243 In order to complete the assessment of the HYBUS performance also a  
244 comparative “back-to-back” test was performed: a city route, the urban Route 48,  
245 was performed with the HYBUS running first, immediately followed by a  
246 conventional bus, so to have the same traffic conditions, measuring at the end the  
247 overall fuel consumption of the two vehicles. Although the aerodynamic drag of the  
248 second bus was affected by the HYBUS, for this comparison these effects could be  
249 neglected, considering the low speeds reached during the test. The conventional

250 bus was a 12 meters long Scania CV AB Omnicity, selected among the newest  
251 part of the Genoa Transit agency fleet. Both the vehicle were ballasted to reach  
252 about 16 tons each.

253 The fuel consumption was measured starting with the full tanks for both the buses  
254 and refilling them at the end of the journey; the consumptions are summarized in  
255 Table 6. Considering the entire cost of fuel and electricity, the HYBUS saved more  
256 than 2€ compared to the Scania

257

### 258 **3. Numerical Simulation of the HYBUS**

259 Once the global features of the HYBUS were defined, extensive simulations were  
260 carried out in order to assess the potential of the selected hybrid powertrain in  
261 terms of fuel economy and to provide a virtual test rig for the development of more  
262 advanced energy management strategies.

263 However, before the simulation model could be used for these analysis, it had to  
264 be validated against experimental measurements, and the data collected during  
265 the Genoa campaign were therefore used as a reference for this purpose.

266 Finally, it is worth to be pointed out that, as far the assessment of the fuel economy  
267 potential is concerned, the HYBUS simulation results were not compared with the  
268 performance of the original bus, but rather with state of the art, EEV (Enhanced  
269 Environmentally-friendly Vehicle) buses of the same class, with which the HYBUS  
270 should compete on the market when transit agencies would need to update their  
271 fleets.

#### 272 **3.1. Model set up**

273 Computer simulations were carried out by means of a vehicle model developed in  
274 GT-Drive [27-29], where the internal combustion engine and the electric machines  
275 are represented through performance maps, which were experimentally measured  
276 under steady state operating conditions. Hence, although system dynamics are  
277 taken into account, the simulation model follows a “quasi-static” approach, because  
278 engine and electric machines behavior is described by steady state maps. This  
279 simulation approach has been demonstrated to be appropriate for the evaluation of

280 instantaneous fuel consumption of light-duty vehicles [30] over the most common  
281 regulatory driving cycles, due to the moderate speed (typically between 0 – 130  
282 km/h) and load transients which are usually prescribed, while the assessment of  
283 the simulation accuracy for urban buses driving cycles has been discussed in  
284 previous works of the research group, such as for instance in [31].

285 Driver behavior is represented through the use of a Proportional-Integral-Derivative  
286 (PID) controller aiming to follow the driving cycle schedule. A BMS (Battery  
287 Management System) handles the electric power flow avoiding dangerous  
288 overcurrent and aiming to maximize battery life by controlling the charge-discharge  
289 cycles of the battery pack.

290 Furthermore, during decelerations the braking controller exploits the traction  
291 electric motors to regenerate a part of the kinetic energy of the vehicle. The  
292 remaining of the braking energy required is provided by conventional brakes.

293 Finally, an APU Controller Unit manages the system according to a simple rule-  
294 based power management strategy.

### 295 **3.2. HYBUS Model Validation**

296 The experimental data collected during the Genoa campaign were used to validate  
297 the HYBUS model.

298 For this purpose the speed and grade profiles of the Forward route 18 have been  
299 used as model inputs, together with the experimentally measured auxiliary power  
300 absorption.

301 The agreement between the numerical and experimental results is quite  
302 satisfactory, as one can see from Figure 9 and 10, as well as from data reported in  
303 Table 7.

304 The ICE operating points are depicted in Figure 11. Results from the model are in  
305 relatively good agreement with the experimental data, although some  
306 discrepancies can be clearly seen, due to unavoidable differences in the  
307 implementation inside the real ECU. However, the gap in the total fuel consumption  
308 over the trip is limited, as summarized in Table 7, and the model accuracy can thus  
309 be considered as satisfactory.

310  
311

### **3.3. HYBUS potential assessment through numerical simulation**

312 The HYBUS fuel consumption results obtained through numerical simulation were  
313 then compared with the experimental results obtained by an Irisbus CITELIS S  
314 Diesel EEV bus, on the same driving cycle [32], as summarized in Table 8.

315 A noticeable fuel saving of the HYBUS compared to the Irisbus equipped with a  
316 conventional powertrain was observed, with a total fuel saving of 46 %. Obviously  
317 one of the drawbacks of the plug-in hybrid vehicle is the battery energy depletion,  
318 which, in this case, is estimated as 57% of the fuel energy. On one hand the  
319 contribution of the battery reduces the local pollutant emissions, but on the other  
320 hand, the financial saving of this solution depends on the price of the electricity for  
321 the transit agency. Nevertheless the HYBUS allows an impressive 45% energy  
322 cost saving compared to the Irisbus. However, it has to be pointed out that, in order  
323 to enable the achievement of such results, it should be possible to recharge the  
324 HYBUS battery from the grid at the end of the line stops and/or at the garage  
325 overnight: this could represent an issue for transit agencies, since all end of the  
326 line stops and garages should be equipped with chargers and safety problems due  
327 to the high voltage should be managed. For this reason, the capability of the  
328 HYBUS to operate in charge sustaining mode was also explored in a later phase of  
329 the project, as discussed in the following Section 4.

## **4. Energy Management Strategy development**

331 After the validation of the simulation model, further improvements of the energy  
332 management strategy were then investigated numerically, since the optimal control  
333 of the power flows in a hybrid vehicle is one of the keys to obtain a significant  
334 advantage in terms of fuel consumption.

335 Usually, due to the a-priori knowledge of the mission profile and the high  
336 computational requirements, Energy Management Strategies (EMS) optimization  
337 cannot be performed in real-time on hybrid vehicles. Nevertheless, for urban buses  
338 the mission profile can be known a-priori, at least to a certain extent, thus paving  
339 the way to the development of "route-tailored" energy management strategies.  
340 Therefore, a sub-optimal controller was developed based on heuristic rules, which  
341 were determined on the basis of the analysis of the results obtained by means of  
342 Dynamic Programming (DP) simulations. For this purpose, a forward and backward

343 trip, of a real driving cycle representative of a specific route of the Genova transit  
344 agency was used.

#### 345 **4.1. Dynamic Programming – Modelling Approach**

346 DP generates a numerical solution for an optimal control problem and it gives  
347 sufficient conditions for the global optimality. It is based on Bellman's principle of  
348 optimality [33] and is able to manage a dynamic model of the system; since DP is  
349 commonly used to solve time-continuous control problems, the model has to be  
350 discretized in a sequence of time steps for which DP is capable of determining the  
351 optimal control laws. In this work, an open-source MATLAB code developed by the  
352 ETH-Zurich [34] was used for the optimization and coupled with a simplified  
353 kinematic model of the vehicle.

354 The energy management can be optimized through DP using cost functions  
355 focused on different targets, such as for instance the minimum fuel consumption or  
356 the minimum pollutant emissions over a certain cycle. In this case, since the simple  
357 minimization of the fuel consumption is not a suitable target for a plug-in hybrid, the  
358 cost function was defined aiming to minimize the overall CO<sub>2</sub> emissions, including  
359 both emissions generated by the fuel burned by the ICE and the equivalent  
360 emissions due the electrical energy consumption from the battery (which will have  
361 to be recharged from the grid) along a real driving cycle. Previous studies [35]  
362 have highlighted that this approach will lead also to the minimization of the total  
363 cost of the fuel and of the electricity. Therefore, the cost function to be minimized  
364 can be written as:

$$365 \quad \min J = \int_0^T \left( \dot{CO}_{2f}(t, u(t)) + \dot{CO}_{2e}(t, u(t)) \right) dt \quad (1)$$

366 with:

$$367 \quad \dot{CO}_{2f} = \frac{\mu_{CO_2}}{\mu_{fuel}} \cdot \dot{m}_f \quad (2)$$

$$368 \quad \dot{CO}_{2e} = k_{CO_2} \cdot SoC \cdot E_{Batt, Norm} \quad (3)$$

369 where  $J$  is the cost-to-go function,  $CO_{2,f}$  is the instantaneous  $CO_2$  emission rate  
370 due to the burned fuel and thus is determined by the instantaneous fuel rate  $\dot{m}_f$   
371 with the knowledge of molar masses of  $CO_2$  and fuel;  $CO_{2,e}$  is the equivalent  $CO_2$   
372 emission rate arising from the instantaneous State Of Charge (SOC) variation of  
373 the battery, which can be estimated using equation (3) by means of the nominal  
374 energy of the battery  $E_{Batt, Norm}$  and the  $CO_2$  conversion factor  $k_{CO_2}$ ;  $u(t)$  is the  
375 vector of the control variable and  $T$  is the period corresponding to the duration of  
376 the driving cycle.

377 Although the HYBUS is a plug-in HEV and its battery could be recharged by the  
378 grid at the end of the day or at end of line stops, due to the issues and of the  
379 modifications that should be necessary to the infrastructure, in order to evaluate  
380 the fuel economy improvements which could be achieved by the HYBUS without  
381 any modifications of the infrastructures, the operation of the HYBUS in charge-  
382 sustaining mode was also simulated.

383 Finally it should be pointed out that, after removing the constraints applied to the  
384 ICE during the experimental tests to preserve the first prototype of the HYBUS,  
385 was now free to operate on its Optimal Operating Line (OOL), as shown in Figure  
386 14, corresponding to the minimum Brake Specific Fuel Consumption (BSFC).

#### 387 **4.2. Dynamic programming – Results & Rule Extraction**

388 The starting point to define a rule based energy management strategy is the  
389 analysis of the optimal strategy identified through the DP. The results obtained  
390 through the DP can as a matter of fact provide helpful information concerning the  
391 decisions that can be implemented in the rule based algorithm.

392 The SOC variation determined by the DP are shown in Figure 12 over the entire  
393 real driving cycle: it can be clearly seen that, with an initial value of the SOC equal  
394 to 0.68, the DP proved to be able to guarantee the charge sustainability. A zoomed  
395 in portion of the driving cycle is also reported in Figure 13, showing the requested  
396 power from the internal combustion engine: the most frequently requested power is  
397 about 56 kW, while the working points are exclusively located on the OOL as  
398 shown in Figure 14. Finally, the choice between the two different operating modes,  
399 i.e. pure Electric Vehicle (EV) and Series Hybrid mode, operated by the DP is

400 shown in Figure 15: it is pretty evident that series hybrid mode is mainly exploited  
401 when the power demand is high, e.g. during strong accelerations.

402 The operating modes selected by the Dynamic Programming were then further  
403 analyzed in order to point out any dependencies from significant input variables,  
404 which could be useful to extract a set of rules for a rule-based energy management  
405 strategy to be implemented in the VMU: some results of these analysis are shown  
406 in Figures 16 and 17. It is quite clear that the hybrid mode is mainly exploited  
407 during vehicle accelerations, at speeds higher than 4 km/h, and at high power  
408 requests levels, higher than 13 kW. However, it was not possible to infer any  
409 dependence of the operating mode selection from the battery state of charge.  
410 Therefore, a simple SOC threshold was established to choose between EV and  
411 hybrid mode selection when the battery is almost depleted.

#### 412 **4.3. Rule based strategy performance evaluation**

413 After extracting a set of rules from the analysis of the Dynamic Programming and  
414 implementing these rules in a heuristic energy management strategy, its  
415 performance was evaluated against both DP and experimental results.

416 It is worth to be recalled however, that, while the newly developed heuristic  
417 strategy and the DP are both aiming to achieve a charge sustaining condition, the  
418 only experimental results available for the comparison were obtained in charge  
419 depleting mode during the previous phases of the project.

420 The new controller was able to manage the SOC and guarantee the charge-  
421 sustainability (see Figure 18). On the other hand, it is worth to be noticed that  
422 during the experimental test on the field in Genova the final SOC decreased to  
423 54%. Consequently, the electrical energy consumed over the real driving cycle was  
424 about 14 kWh, with a specific electricity consumption of 0.75 kWh/km.

425 Moreover, it should be pointed out that, due to the engine's limitation on the  
426 HYBUS prototype, the instantaneous power of the ICE was restricted to 5 to 15 kW  
427 during the experimental tests, while both the DP and the newly developed control  
428 strategy were capable to operate the ICE in the high load and high efficiency zone  
429 of the map, as shown in Figure 19.

430 The cumulative fuel consumption is shown in Figure 20. While the real test  
431 achieved the minimum fuel consumption, with 4.12 kg, the additional energy  
432 consumption in terms of battery depletion should be taken into account, in order to  
433 allow a proper comparison between charge sustaining and charge depleting  
434 strategies.

435 A comparison regarding the total cost over the driving cycle is reported in Table 9.  
436 The experimental test achieved a 29.8% reduction compared to a conventional  
437 bus, while for the novel controller the improvement was of 28.7%. Therefore, the  
438 strong improvement introduced by the first HYBUS prototype could be maintained  
439 also with the notable limit on the battery SOC and avoiding the need of charging  
440 phases in the garage at the end of the day.

441

## 442 **5. Conclusions**

443 A prototype hybrid urban bus, called HYBUS, was built by integrating an innovative  
444 hybrid propulsion system featuring a plug-in series architecture into the chassis of  
445 an old diesel bus.

446 The prototype was then extensively tested in the city of Genoa, Italy, an urban  
447 context extremely challenging for a hybrid powertrain due to its frequent uphill  
448 routes and significant road grades.

449 The main outcomes of the tests were the followings:

- 450 • The HYBUS prototype system allowed fuel consumption reductions ranging  
451 from 27 % up to 45 % respectively, if compared with the newest buses or  
452 with the average buses of the Genoa transit agency fleet.
- 453 • Considering the current costs of diesel fuel and of electricity, and the  
454 amount of electric energy needed to restore the battery state of charge of  
455 the HYBUS at the end of the trip, the money savings corresponding to the  
456 abovementioned fuel savings were equal to 17% and 33% respectively.
- 457 • The HYBUS hybrid propulsion system demonstrated to be suitable also for  
458 urban routes with significant grades.

- 459       • Numerical simulations proved that issues related to the battery recharge can  
460       be solved by introducing a new charge sustaining control strategy, while  
461       maintaining significant operating cost reductions in comparison with busses  
462       equipped with conventional diesel powertrains.

463       In conclusion the HYBUS was proved to represent an effective way to reduce fuel  
464       consumptions and operating costs of transit agencies' fleets, offering an interesting  
465       option for the revamping of the oldest buses.

## 466       **6. Acknowledgements**

467       The authors would like to gratefully acknowledge the valuable contribution of  
468       Pininfarina, and of the transit agencies of the cities of Turin and Genoa.

469

## 470       **7. Funding**

471       This work was financially supported by the Regione Piemonte in the framework of  
472       the AMPERE project.

## 473       **8. Definitions and Abbreviations**

<i>APU</i>	<i>AUXILIARY POWER UNIT</i>
<i>BMEP</i>	<i>BRAKE MEAN EFFECTIVE PRESSURE</i>
<i>BMS</i>	<i>BATTERY MANAGEMENT SYSTEM</i>
<i>BSFC</i>	<i>BRAKE SPECIFIC FUEL CONSUMPTION</i>
<i>DP</i>	<i>DYNAMIC PROGRAMMING</i>
<i>EEV</i>	<i>ENHANCED ENVIRONMENTALLY FRIENDLY VEHICLE</i>
<i>EM</i>	<i>ELECTRIC MOTOR</i>
<i>EMS</i>	<i>ENERGY MANAGEMENT SYSTEM</i>

<i>EV</i>	<i>ELECTRIC VEHICLE</i>
<i>GTT</i>	<i>GRUPPO TORINESE TRASPORTI</i>
<i>HEV</i>	<i>HYBRID ELECTRIC VEHICLE</i>
<i>HHV</i>	<i>HYDRAULIC HYBRID VEHICLE</i>
<i>ICE</i>	<i>INTERNAL COMBUSTION ENGINE</i>
<i>OOL</i>	<i>OPTIMAL OPERATING LINE</i>
<i>PID</i>	<i>PROPORTIONAL INTEGRAL DERIVATIVE</i>
<i>SOC</i>	<i>STATE OF CHARGE</i>
<i>SORT</i>	<i>STANDARDIZED ON-ROAD TEST CYCLES</i>
<i>VMU</i>	<i>VEHICLE MANAGEMENT UNIT</i>

## 474 **9. References**

- 475 1. GTT, "Relazione e Bilancio al 31 Dicembre 2012",  
476 [http://www.gtt.to.it/gruppo/Bilancio\\_2012.pdf](http://www.gtt.to.it/gruppo/Bilancio_2012.pdf) (in Italian), accessed on Jan. 30<sup>th</sup>,  
477 2015.
- 478 2. Millo, F., Fuso, R., Rolando, L., Zhao, J. et al., "HYBUS: A New Hybrid Bus for  
479 Urban Public Transportation," *SAE Technical Paper 2013-24-0081*, 2013,  
480 doi:10.4271/2013-24-0081.
- 481 3. Louvigny, Y., Nzisabira, J. and Duysinx, P.: "Analysis of hybrid hydraulic  
482 vehicles and comparison with hybrid electric vehicles using batteries or super  
483 capacitors", EET-2008 European Ele-Drive Conference, *International Advanced  
484 Mobility Forum*, 11-13 March 2008, Geneva-Switzerland.
- 485 4. De Lorenzo, G., et al. "Numerical simulation model for the preliminary design of  
486 hybrid electric city bus power train with polymer electrolyte fuel cell",  
487 *International Journal of Hydrogen Energy*, Volume 39, Issue 24, 13 August  
488 2014, Pages 12934-12947.
- 489 5. de Oliveira, L. A., et al. "A financial and environmental evaluation for the  
490 introduction of diesel-hydraulic hybrid-drive system in urban waste

- 491 collection." *Transportation Research Part D: Transport and Environment*,  
492 Volume 31, August 2014, Pages 100-109.
- 493 6. Ribau, J. P et al. "Efficiency, cost and life cycle CO<sub>2</sub> optimization of fuel cell  
494 hybrid and plug-in hybrid urban buses." *Applied Energy*, Volume 129, 2014,  
495 Pages 320-335.
- 496 7. Briggs, I. et al. "Whole-vehicle modelling of exhaust energy recovery on a  
497 diesel-electric hybrid bus." *Energy*, Volume 65, 2014, Pages 172-181.
- 498 8. Wang, L., et al. "Hardware-in-the-loop simulation for the design and verification  
499 of the control system of a series-parallel hybrid electric city-bus." *Simulation  
500 Modelling Practice and Theory*, Volume 25, 2012, Pages 148-162.
- 501 9. Hu, X., et al. "Energy efficiency analysis of a series plug-in hybrid electric bus  
502 with different energy management strategies and battery sizes." *Applied Energy*  
503 Volume 111, 2013, pages 1001-1009.
- 504 10. Clark, N.N., and Zhen, F.: APPLICATIONS – TRANSPORTATION | Buses:  
505 ICE/Battery Hybrids, In *Encyclopedia of Electrochemical Power Sources*, edited  
506 by Jürgen Garche, Elsevier, Amsterdam, 2009, Pages 203-218, ISBN  
507 9780444527455, <http://dx.doi.org/10.1016/B978-044452745-5.00884-4>.
- 508 11. Xiong, Weiwei, Yong Zhang, and Chengliang Yin. "Optimal energy  
509 management for a series-parallel hybrid electric bus." *Energy conversion and  
510 management*, 50.7 (2009): 1730-1738.
- 511 12. Liang, X., Wang, C., Chapelsky, C., Koval D. and Knight, A. M.: "Analysis of  
512 Series and Parallel Hybrid Bus Fuel Consumption of Different Edmonton Transit  
513 System Routes", *5<sup>th</sup> IEEE Vehicle Power and Propulsion Conference, VPPC  
514 '09*, 7-10 September 2009, Dearborn, pp. 1470-1475.
- 515 13. Frey, H. C., Roupail, N. M., Zhai, H., Farias T. L., and Goncalves, C. A.:  
516 "Comparing Real-World Fuel Consumption for Diesel and Hydrogen-Fueled  
517 Transit Buses and Implications for Emissions", *Transportation Research Part D:  
518 Transport and Environment*, Vol. 12, No. 4, 2007, pp. 281-291.
- 519 14. Kies, A., Luz, R., Silberholz, G., Hausberger, S.: "Influence of the driving style  
520 on fuel consumption and battery wear of a parallel hybrid city bus", 13th  
521 Stuttgart International Symposium, 26-27 February 2013, Stuttgart, Germany.
- 522 15. Lajunen, Antti. "Energy consumption and cost-benefit analysis of hybrid and  
523 electric city buses." *Transportation Research Part C: Emerging Technologies*38  
524 (2014): 1-15.

- 525 16. Torino Oggi, "Torino: in arrivo 100 nuovi autobus GTT di ultima generazione",  
526 [http://www.torinoggi.it/attualita/3521-torino-in-arrivo-100-nuovi-autobus-gtt-di-](http://www.torinoggi.it/attualita/3521-torino-in-arrivo-100-nuovi-autobus-gtt-di-ultima-generazione.html?pag=3264)  
527 [ultima-generazione.html?pag=3264](http://www.torinoggi.it/attualita/3521-torino-in-arrivo-100-nuovi-autobus-gtt-di-ultima-generazione.html?pag=3264) (in Italian), accessed on March 2<sup>th</sup>, 2015
- 528 17. GTT, "Relazione e bilancio al 31 dicembre 2010",  
529 <http://www.gtt.to.it/gruppo/GTT%20Bilancio%2031%20dicembre%202010.pdf>  
530 (in Italian), accessed on March 2<sup>th</sup>, 2015
- 531 18. Rinnovabili.it, [http://www.rinnovabili.it/storico/arrivano-7-bus-ibridi-diesel-](http://www.rinnovabili.it/storico/arrivano-7-bus-ibridi-diesel-elettrico-2/)  
532 [elettrico-2/](http://www.rinnovabili.it/storico/arrivano-7-bus-ibridi-diesel-elettrico-2/) (in Italian), accessed on March 2<sup>th</sup>, 2015
- 533 19. EESI, "HYBRID BUSES COSTS AND BENEFITS",  
534 [http://www.eesi.org/files/eesi\\_hybrid\\_bus\\_032007.pdf](http://www.eesi.org/files/eesi_hybrid_bus_032007.pdf), accessed on March 2<sup>th</sup>,  
535 2015
- 536 20. GTT, "Parco Veicoli – scheda tecnica", October 2012  
537 [http://www.comune.torino.it/gtt/gruppo/veicoli/parco\\_veicoli\\_tpl.pdf](http://www.comune.torino.it/gtt/gruppo/veicoli/parco_veicoli_tpl.pdf) (in Italian),  
538 accessed on Jan. 30<sup>th</sup>, 2015.
- 539 21. GTT, "Rete Urbana e suburbana - Autobus in servizio", October 2012  
540 <http://www.comune.torino.it/gtt/gruppo/veicoli/autobus.shtml> (in Italian),  
541 accessed on Jan. 30<sup>th</sup>, 2015.
- 542 22. "Standardised On-Road Test Cycles - SORT – A project of the UITP Bus  
543 Committee in collaboration with manufacturers", 54<sup>th</sup> International UITP  
544 Congress, London, 20-25 May 2001.
- 545 23. Millo F., Rolando L., Andreatta M., Numerical Simulation for Vehicle Powertrain  
546 Development, In: *Numerical Analysis - Theory and Application* / Awrejcewicz  
547 J., InTech, Rijeka, pp. 519-540. ISBN 9789533073897
- 548 24. Guzzella, L., & Sciarretta, A. (2007). Vehicle propulsion systems (Vol. 1).  
549 Springer-Verlag Berlin Heidelberg.
- 550 25. Valence, "Why use Valence Lithium Phosphate?",  
551 <https://www.valence.com/why-valence/>, accessed on March 2<sup>th</sup>, 2015
- 552 26. Millo, F., Rolando, L., Fuso, R., & Mallamo, F. (2014). Real CO2 emissions  
553 benefits and end user's operating costs of a plug-in hybrid electric vehicle.  
554 *Applied Energy*, 114, 563-571
- 555 27. GAMMA TECHNOLOGY, (2013) GT-Suite User Manuals. Chicago, United  
556 States.
- 557 28. Ciesla, C., Keribar, R., and Morel, T., "Engine/Powertrain/Vehicle Modeling Tool  
558 Applicable to All Stages of the Design Process," SAE Technical Paper 2000-01-  
559 0934, 2000, doi: 10.4271/2000-01-0934.

- 560 29. Morel, T., Keribar, R. and Leonard, A., "Virtual Engine/Powertrain/Vehicle  
561 Simulation Tool Solves Complex Interacting System Issues", SAE Technical  
562 Paper 2003-01-0372, 2003.
- 563 30. Cipolla, G., Mallamo, F., Paladini, V., Vassallo, A., Millo, F., and Mafrici, G.:  
564 "Transient Correction of Diesel Engine Steady-State Emissions and Fuel  
565 Consumption Maps for Vehicle Performance Simulation", 16<sup>th</sup> Aachener  
566 Kolloquium Fahrzeug und Motorentechnik, Aachen, Germany 2007.
- 567 31. Millo, F., Mallamo, F., Pautasso, E. and Ganio Mego, G.: "The potential of  
568 Electric Exhaust Gas Turbocharging for HD Diesel Engines", SAE Technical  
569 Paper 2006-01-0437, 2006.
- 570 32. FVT Report – "Emissions and Fuel Consumption of Clean City Bus Concepts" –  
571 Report No. FVT/85/06/ Haus Em 29/04-6770 from 16.11.2006.
- 572 33. R. E. Bellman, Dynamic programming. Princeton - N.J.: Princeton University  
573 Press, 1957.
- 574 34. Sundstrom, O., and Guzzella, L. "A generic dynamic programming Matlab  
575 function." Control Applications, (CCA) & Intelligent Control, (ISIC), 2009 IEEE.  
576 IEEE, 2009.
- 577 35. Millo, F., Rolando, L., Mallamo, F., and Fuso, R.: "Development of an optimal  
578 strategy for the energy management of a range-extended electric vehicle with  
579 additional noise, vibration and harshness constraints," *Proceedings of the  
580 Institution of Mechanical Engineers, Part D: Journal of Automobile Engineering*,  
581 vol. 227, pp. 4-16, 2012.