

Second law analysis of horizontal geothermal heat pump systems

Original

Second law analysis of horizontal geothermal heat pump systems / Verda, V., Cosentino, S., LO RUSSO, S., Sciacovelli, A.. - In: ENERGY AND BUILDINGS. - ISSN 0378-7788. - 124:(2016), pp. 236-240. [10.1016/j.enbuild.2015.09.063]

Availability:

This version is available at: 11583/2651388 since: 2016-11-15T12:43:32Z

Publisher:

Elsevier

Published

DOI:10.1016/j.enbuild.2015.09.063

Terms of use:

This article is made available under terms and conditions as specified in the corresponding bibliographic description in the repository

Publisher copyright

(Article begins on next page)

Second law analysis of horizontal geothermal heat pump systems

Vittorio Verda^a, Sara Cosentino^b, Stefano Lo Russo^c and Adriano Sciacovelli^d

^a Politecnico di Torino Dipartimento Energia, Torino, Italy, vittorio.verda@polito.it

^b Politecnico di Torino Dipartimento Energia, Torino, Italy, sara.cosentino@polito.it

^b Politecnico di Torino Dipartimento di Ingegneria dell'Ambiente, del Territorio e delle Infrastrutture, Torino, Italy, stefano.lorusso@polito.it

^d Politecnico di Torino Dipartimento Energia, Torino, Italy, adriano.sciacovelli@polito.it

Abstract:

This paper presents an exergetic analysis of the operating conditions of a shallow horizontal ground source heat pump. The analysis is conducted through theoretical evaluation of the exergy potential and the evaluation of the main sources of unavoidable irreversibilities. This approach can be used to assess the main causes of performance reduction and degradation, as well as to select the optimal installation (depth, position) or to modify the operating parameters.

The analysis of a real installation is then considered. This is a horizontal ground heat exchanger, constituted of a network of pipes installed 1 m below the surface, covering an area of about 210 m². A comparison of the current installation with a deeper installation, 2 m below the surface, shows that the exergy output can be increased of more than 60%. This improvement can be easily compared with the increase in the installation costs in order to evaluate the optimal depth.

Keywords:

Exergy analysis, Ground heat exchanger, design improvement.

1. Introduction

Geothermal energy is a renewable and diffuse alternative energy source which is expected to play a significant role in sustainable energy development. Geothermal heating and cooling systems are good solutions in terms of investment and operating costs, especially in temperate climates [1]. Horizontal ground source heat pumps (GSHPs) are closed-loop systems that utilize shallow ground as a heat sink or source. In heating mode, heat absorbed from the ground feeds the evaporator of the heat pump; its thermal level is then increased by the compressor. Heat is then supplied to the heating system of the building by the condenser. In cooling mode, heat is absorbed from the building and transferred to the evaporator and then discharged, at higher temperature, to the ground by the horizontal ground heat exchangers (HGHEs) connected to the condenser. In GSHP systems using conventional HGHEs, a network of straight polyethylene pipes lie at the bottom of horizontal trenches [2] or excavations.

Considerable research has been focused on modeling and simulation of vertical borehole ground heat exchangers, with less focus on the modeling of HGHE systems, due to complex transients at the ground surface caused by weather and climatic conditions. The reliable quantification of vertical transient heat fluxes across a topographic surface directed to the ground is often impeded by a lack of suitable meteorological data. In the absence of appropriate data, the topographic surface is usually considered as adiabatic, and heat transfer from the surface is disregarded [3-11]. The main input data for calculation models for GHEs generally include the geometric characteristics of the system, thermal characteristics of the ground and pipes, and undisturbed ground temperature during system operation [12].

Several recent works on slinky-coil horizontal ground heat exchangers are also available in the literature. Fujii and co-workers [13] have applied a numerical analysis using the software FEFLOW to predict the performances of a horizontal heat exchanger. Congedo and coworkers [14] have developed a numerical model using the software Fluent to evaluate the effects of fluid velocity and depth of installation on the annual performances. In [15] a numerical analysis is performed in order to investigate the effects of the coil diameter on the heat extraction.

In the present work, a numerical analysis of ground heat exchangers is combined with exergy analysis. There are various papers in the literature proposing exergy analysis of geothermal heat pumps (see for example [16-18]). These are mainly focused on the design and analysis of the heat pump. This work, instead, is focused on the analysis of the ground heat exchangers, with the goal of highlighting possible improvements in the design or operation. In fact, exergy analysis allows one obtaining quantitative and coherent evaluation of the possible sources of irreversibilities that limit the energy performance of the entire system. The proposed procedure is alternative to parametric simulation of the complete ground heat exchanger and can be based on a simpler thermofluid dynamic model. This allows one to overcome problems related with the typically large aspect ratios that are involved in the simulation of the full system.

2. Exergy analysis of ground heat exchangers

One of the most interesting uses of the concept of exergy consists in comparing different forms of energy, or energies of different quality. Through the concept of exergy, all forms of energy are converted into the same form, i.e. work. Exergy is the maximum amount of work that can be obtained from an amount of energy, using it in a device which only interacts with the biosphere.

In the case of ground heat exchangers, exergy allows one to analyse the heat fluxes exchanged in a system also taking the temperatures of the source and external environment into account. The first temperature depends on the characteristics of the location, the depth of the ground heat exchanger and the operating conditions. In the case of shallow installations in urban areas, possible interactions between the ground heat exchanger and buildings, underground stations or tunnels, etc. might be also relevant. The temperature of the external environment, for a specific location, depends on the season, day and hour. Exergy associated with an amount of heat, extracted from the ground or injected, increases with increasing difference between these two temperatures.

An evaluation of the ground temperature as the function of time and depth can be obtained using the Kasuda equation [19], which behaviour is shown in Figure 1a in the particular case of a soil with thermal diffusivity of $0.4 \text{ m}^2/\text{s}$, annual average temperature of $15 \text{ }^\circ\text{C}$ and temperature variation amplitude of $17 \text{ }^\circ\text{C}$. The specific exergy of a heat flux exchanged with the ground can be obtained as

$$\theta = \left| 1 - \frac{T_0}{T} \right| \quad (1)$$

where T_0 is the ambient temperature and T the local temperature of the ground (both in K). The reason for the absolute value is related with the sign of the heat flux, which is positive when subtracted from the ground and negative when injected. In the first case, ground temperature is generally larger than ambient temperature while the opposite occurs in the second case. The specific exergy corresponding to temperature distributions of Figure 1a is shown in Figure 1b.

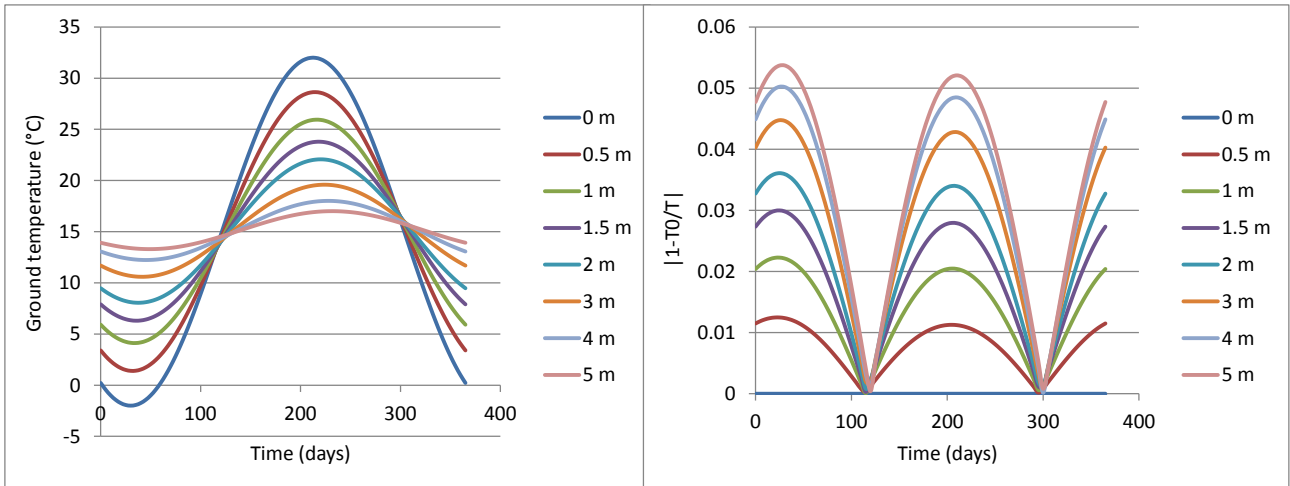

Figure 1 – Ground temperature (a) and specific exergy of a heat flux exchanged with the ground (b)

These curves show that there is no exergy transfer involved in the case of an installation on the surface. Specific exergy increases with the depth. Moreover, the largest advantage of deeper installations is particularly evident in the case of the coldest and warmest days. These are also the days with the largest heating and cooling requests and the largest heat fluxes exchanged with the ground. The marginal advantage in deeper installations decreases with the depth. This quantity is about 0.02 1/m for installations at 0.5 m and 0.001 1/m for installations at 5 m.

This evaluation is ideal since it does not consider two major effects: the resource degradation during its utilization and the temperature gradients in the portion of ground close to the heat exchanger. Both effects are related with the finite surface of the ground heat exchanger and can be evaluated using a numerical model. Using the continuum approach, exergy destruction can be calculated by applying the Guy-Stodola theorem and considering the expression of entropy generation due to heat transfer [20]:

$$\Psi_d = T_0 \cdot \Sigma_i = T_0 \cdot \int \frac{k}{T^2} (\nabla T)^2 \cdot dV \quad (2)$$

where k is the ground conductivity. This quantity mainly depends on the time variation of the heat flux. In the case of balanced heat request, exergy destruction does not depend significantly on the depth, as highlighted by the comparison shown in figure 2. This figure reports the distributions of exergy destruction per unit volume for two installations at different depths: 1 m (figure 2 left) and 2 m (figure 2 right). These plots refer to the maximum heat request in the coldest winter day (about 38 W/m^2). It is shown that irreversibilities due to the heat transfer with the ground do not significantly depend on the depth of installation. This means that this quantity is not particularly affected by the differences in the temperature distributions. Similar conclusions can be drawn in the case of smaller heat flux, therefore it is possible to state that, for a given heat flux, an increase in the exergy of the resource (the ground) becomes an equal increase in the exergy associated with the product (the fluid).

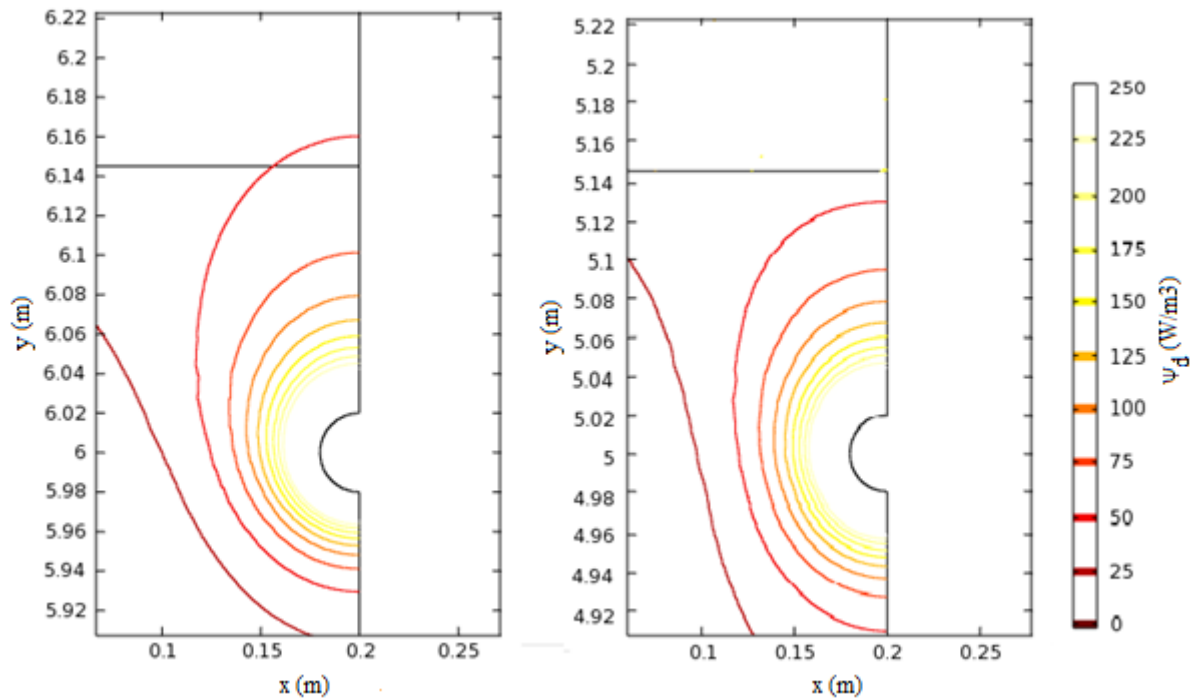

Figure 2 – Specific exergy destruction in the case of maximum heat request for a 1m depth installation (left) and 2m depth installation (right).

3. Application to a real installation

The horizontal GSHP system considered in this study is installed at the Caleffi Research Center, located in Fontaneto d'Agogna, in the North of Italy. The building connected to the existing GSHP plant, called the "Cubo Rosso" (which means the red cube), is used for research offices and laboratories. This system has been selected in the present work as it is a good example of the advantages of a second-law design approach with respect to parametric simulation of the full system.

The HGHEs are buried about 1 m below the surface and cover an area of 210 m². This closed-loop system is designed to meet heating and cooling requirements of the building during periods of high energy demand. The exchangers are separated into 3 circuits of 70 m². Each area is formed by 160 m of high density polyethylene pipes (HDPEs) 32 × 2.9 mm. The fluid in the pipes is a solution of water and propylene glycol (50%). The pipes are connected in series, and the wheelbase between the pipes is about 40 cm. The overall HGHE system is connected to an electrically driven 8-kW heat pump located in the main building.

Ground temperature distribution is measured by 5 thermometers, positioned about 80 cm below the ground surface. The thermometers are located at the 4 corners and at the center of the area, as shown in Fig. 3.



Fig. 3. View of the pipes and position of the thermometers.

The portion of ground which is of interest in the present analysis consists of alluvial deposits (Torrent Agogna Complex), mainly composed of gravel in a coarse sandy matrix and fluvio-glacial deposits (Borgomanero Complex), constituted by heterogeneous-grained sediments, with large clasts and blocks in sandy-silty matrix. The hydrogeological setting is well known thanks to vertical boreholes drilled in the same area. The unconfined aquifer is associated with a groundwater level of approximately 7 m below the ground surface. The groundwater level does not experience significant fluctuations throughout the year.

Thermal material properties in the subdomains are assumed to be homogeneous and isotropic: thermal conductivity 3 W/mK, density 1580 kg/m³, specific heat 700 J/kgK.

The HGHE (cylindrical pipe system) is modelled considering 18 cylinders, each corresponding to a single pipe, as shown in Figure 4. Only the longitudinal development of pipes is considered. U-bends are substituted with appropriate continuity boundary conditions, so that the temperature of the fluid entering the U-bend is equal to the temperature of the fluid exiting it. The linear development of each pipe is increased in order to account for the U-bend length. Depending on the objective of the simulation an appropriate boundary condition should be assumed at the pipes. If the objective consists in the calculation of the temperature evolution in the ground, heat flux can be prescribed on the external surface of the pipes. If the objective consists in a prediction of the operation of the heat pump, fluid flow in the tubes should be considered and then water temperature should be imposed on the inlet sections (I1, I2 and I3 in figure 4) and a convective flow condition should be imposed on the outlet sections (O1, O2 and O3). Moreover, inlet temperature should be related with the heat pump operation. This second type of simulation is much more problematic because of the geometrical aspect ratios of the system: the pipe diameter is only few centimetres while its length is various meters and the ground domain is various meters large and deep. This requires large computational efforts, also considering that a time dependent simulation is necessary.

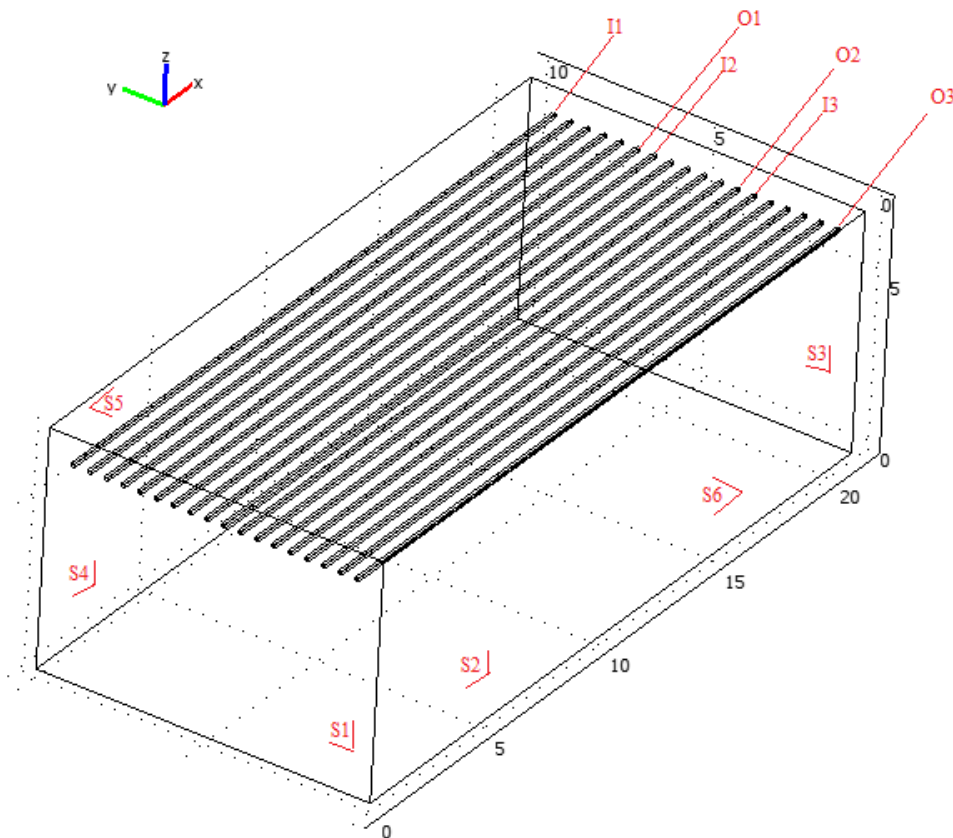

Figure 4. Computational domain for the complete system

Two of the vertical boundary surfaces of the domain are considered as adiabatic (surfaces S1 and S2 in figure 4), while a Robin condition is imposed on the two surfaces facing the building (surfaces S3 and S4 in figure 4) up to a depth of 4m. This is performed to take into account the thermal perturbations of the ground temperature due to the heat losses/gains of the underground level of the building. These boundary conditions are positioned in correspondence of the two walls shown in figure 3. For the remaining portion of the surfaces, a linear reduction down to the groundwater temperature is considered. The internal temperature in the basement of the building is calculated along the year through a dynamic model built in EnergyPlus since this information was not monitored during the year. The calculated annual temperature in the basement is shown in figure 5.

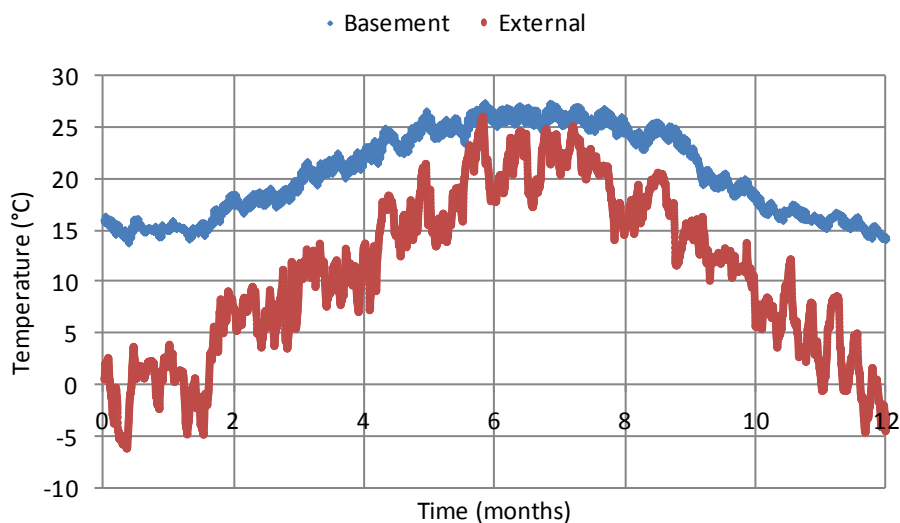

Figure 5. Air temperature in the basement and external temperature

A constant temperature (Dirichlet condition) equivalent to the temperature of the aquifer is imposed on the bottom surface (surface S6). Groundwater temperature is practically constant during the year and equal to 14 °C. A Robin boundary condition is finally considered on the top surface (surface S5). The initial condition for each simulation is the undisturbed earth temperature, i.e. the temperature distribution that was registered in January, before the system was switched on.

Temperatures registered by the thermometers show unexpected deviations. In particular, temperatures T1 and T2 are always very close, but different than the values of T3-T5, which are very close between them. These values are shown in figure 6 with plane lines. Temperatures T1-T2 are labelled as “undisturbed” (the average of the two values is shown), while temperatures T3-T5 are labelled as “near” (the average of the three values is shown). In winter operation, the undisturbed values are smaller than the near values, while the opposite occurs in summer operation. The numerical model confirms that there is an effect due to the interaction between the basement and the pipes, in fact the simulated values of the temperatures in the same points where the thermometers are located show similar trend. If an adiabatic boundary condition on the two surfaces facing the building was assumed, temperatures would be practically the same in all the five points. Despite the differences in the operation, ground temperatures near and far from the building are quite close, therefore a 2D simulation is sufficient to predict ground temperatures.

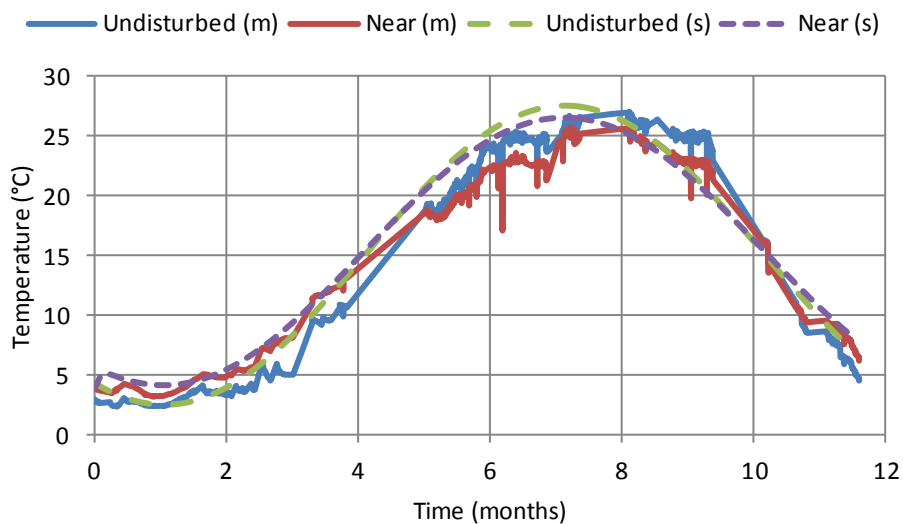

Figure 6. Measured (m) and simulated (s) ground temperatures

Using the numerical results of these simulations it is possible to calculate the exergy flows that are exchanged as the function of the depth of the installation. As an example, figure 7 shows the annual variations of the exergy flows exchanged by the current installation (1 m depth) and a deeper installation (2 m depth). In this latter case, the heat flux exchanged by the heat exchanger has been imposed as equal to that in current installation, to make the results easier to compare. A deeper installation allows to obtain higher water temperature in winter and colder temperature in summer, which also involves a larger exergy flux (+64%). In an ideal (reversible) case an equal reduction in the exergy necessary at the compressor in order to reach the same output exergy would be expected. The real reduction in the compressor power is larger than the additional exergy input because of the avoided irreversibilities in the compressor. This power reduction can be easily converted into economical savings and compared with the increase in the installation costs and then to select the optimal depth for this type of installation.

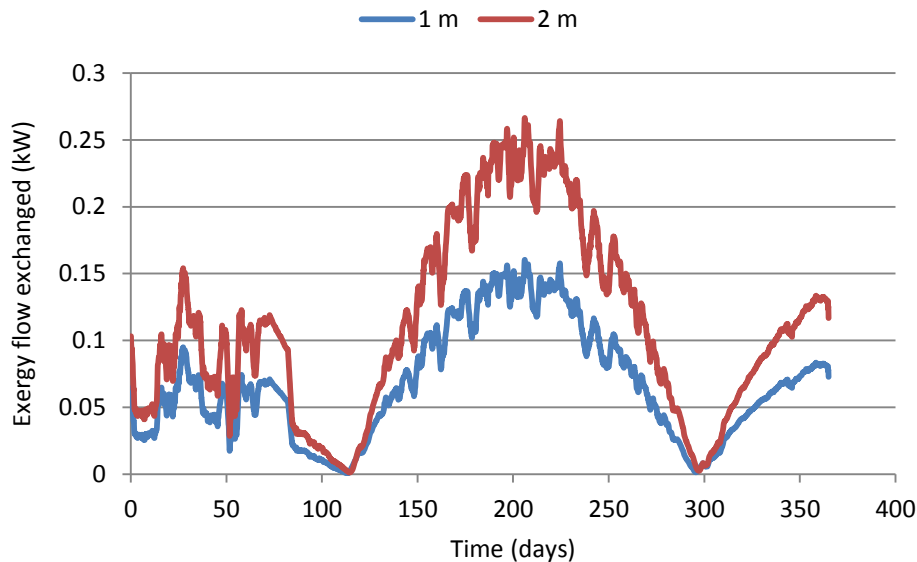

Figure 7. Exergy flows exchanged by a ground heat exchanger at two different depths.

4. Conclusions

In this paper exergy analysis is applied to the design/operation analysis of ground source heat exchangers. The proposed approach allows one to properly evaluate the potential of the resource by considering the differences between ground temperature and ambient temperature, as well as to take the unavoidable irreversibilities due to heat transfer in the ground or the type of heating/cooling load (i.e. balanced or unbalanced load) into account. Such approach gives the designer quantitative and coherent information about the possible improvements in the system that can be achieved by modifying the installation (position, depth) or the design characteristics (pitch, diameter, etc.).

The analysis can be conducted without detailed modeling of the ground heat exchanger, which would require large computational resources due to the large aspect ratios in the geometry and the transient behavior of the system.

The analysis is here used to provide a thermodynamic comparison between different installation depths of an horizontal ground heat exchanger. An application to a real system is proposed. The analysis shows that doubling the installation depth, from 1 m to 2 m, the exergy output increases of about 60%. This piece of information can be used as an input to an economic analysis in order to determine the optimal installation depth.

Further development of this method will be focused in the analysis of the effects due to the type of heating/cooling load and in the optimal operation.

REFERENCES

- [1] Tester J.W., Drake E.M., Driscoll M.J., Golay M.W. and Peters W.A. (2005). Sustainable Energy Choosing Among Options. MIT Press.
- [2] Kavanaugh, S.P., and Rafferty, K. (1995). *Ground-source heat pumps, design of geothermal systems for commercial and institutional buildings*. Atlanta: ASHRAE.
- [3] Piechowski, M. (1998). Heat and mass transfer model of a ground heat exchanger: theoretical development. *International Journal of Energy Research* 23, 571-588.
- [4] Mihalakakou, G. (2002). On estimating ground surface temperature profiles. *Energy and Buildings* 34, 251-259.
- [5] Inalli, M. and Esen, H. (2004). Experimental thermal performance evaluation of a horizontal ground-source heat pump system. *Applied Thermal Engineering*, 24 (14-15), 2219-32.
- [6] Salah El-Din, MM. (1999). On the heat flow into the ground. *Renewable Energy* 18, 473-490.

- [7] Esen, H., Inalli, M., and Esen, M. (2007). Numerical and experimental analysis of a horizontal ground-coupled heat pump system. *Building and Environment* 42, 1126-1134.
- [8] Burchart A., B. Leppig, B. Müller and G. Wimmer (2006). Mapping the Groundwater Vulnerability in North Rhine–Westphalia, Germany. *Environmental Engineering Science*. July/August 2006, 23(4): 574-578. doi:10.1089/ees.2006.23.574.
- [9] Bottarelli, M., and Di Federico, V. (2010). Adoption of GSHP System at the Residential Micro-Scale: Field Analysis and Energetic Performance. In R. Horne, Ed., *Proceedings World Geothermal Congress 2010*. Bali, Indonesia, 25-29 April 2010.
- [10] Nam, Y., Ooka, R., and Hwang, S. (2008). Development of a numerical model to predict heat exchange rates for a ground-source heat pump system. *Energy and Buildings* 40, 2133-2140.
- [11] Demir, H., Koyun, A., and Temir, G. (2009). Heat Transfer of horizontal parallel pipe ground heat exchanger and experimental verification. *Applied Thermal Engineering* 29, 224-233.
- [12] Florides, G., and Kalogirou, S. (2007). Ground heat exchangers - A review of systems, models and applications. *Renewable Energy* 32, 2461-2478.
- [13] Fujii H., Nishi K, Komaniwa Y., Chou N. (2012). Numerical modeling of slinky-coil horizontal ground heat exchangers. *Geothermics* 41: 55-62.
- [14] Congedo P.M., Colangelo G., Starace G. (2012). CFD simulations of horizontal ground heat exchangers: a comparison among different configurations. *Applied Thermal Engineering* 33-34: 24-32.
- [15] Wu Y., Gan G., Verhoef A., Vidale P.L., Gonzalez R.G. (2010). Experimental measurements and numerical simulation of horizontal-coupled slinky ground source heat exchangers. *Applied Thermal Engineering* 30: 2574-2583.
- [16] M.R. Ally, J.D. Munk, V.D. Baxter, A.C. Gehl (2012). Exergy analysis and operational efficiency of a horizontal ground-source heat pump system operated in a low-energy test house under simulated occupancy conditions. *International Journal of Refrigeration* 35: 1092-1103.
- [17] A. Hepbasli, O. Akdemir (2004). Energy and exergy analysis of a ground source (geothermal) heat pump system. *Energy Conversion and Management* 45: 737–753
- [18] Y. Bi, X. Wang, Y.Liu, H. Zhang, L. Chen (2009). Comprehensive exergy analysis of a ground-source heat pump system for both building heating and cooling modes. *Applied Energy* 86: 2560–2565
- [19] Kasuda, T., and Archenbach, P.R. (1965). "Earth Temperature and Thermal Diffusivity at Selected Stations in the United States", *ASHRAE Transactions*, Vol. 71, Part 1
- [20] Bejan A. (1996). *Entropy Generation Minimization*. CRC Press, Boca Raton, FL