

Developing a low cost multipurpose X-band FMICW radar

*Original*

Developing a low cost multipurpose X-band FMICW radar / Lucianaz, C., Bertoldo, S., Petrini, P., Allegretti, M.. - ELETTRONICO. - 1:(2016), pp. 1-4. (XXI RiNEm, Riunione Nazionale di Elettromagnetismo Parma 12-14 Settembre 2016).

*Availability:*

This version is available at: 11583/2649333 since: 2016-09-15T10:36:49Z

*Publisher:*

SIEM

*Published*

DOI:

*Terms of use:*

This article is made available under terms and conditions as specified in the corresponding bibliographic description in the repository

*Publisher copyright*

(Article begins on next page)

# DEVELOPING A LOW COST MULTIPURPOSE X-BAND FMICW RADAR

C. Lucianaz<sup>(1)</sup>, S. Bertoldo<sup>(1)</sup>, P. Petrini<sup>(1)</sup>, M. Allegretti<sup>(2)</sup>

<sup>(1)</sup> Department of Electronics and Telecommunications (DET),  
Politecnico di Torino

Corso Castelfidardo 39, 10129 Torino, Italy

{[claudio.lucianaz](mailto:claudio.lucianaz@polito.it), [silvano.bertoldo](mailto:silvano.bertoldo@polito.it), [paolo.petrini](mailto:paolo.petrini@polito.it)}@polito.it

<sup>(2)</sup> CINFAI (Consorzio Interuniversitario Nazionale per la Fisica  
delle Atmosfere e delle Idrosfere) c/o Politecnico di Torino

Corso Castelfidardo 39, 10129 Torino, Italy

[marco.allegretti@polito.it](mailto:marco.allegretti@polito.it)

## Abstract

*In the framework of a series of research projects a first prototype of an X-band FMCW (Frequency Modulated Interrupted Continuous Wave) was developed. Its main characteristics are the low cost and the complete software programmability, making it a multipurpose and versatile instrument. Without any hardware modifications and by simply varying the software for data acquisition and processing, it can be used for target detection, as radar altimeter and also for atmospheric monitoring operations (e.g. for rainfall estimation).*

*The present work briefly describes the radar standard electronics and presents the interfaces of the processing software. Some results are also given.*

**Index Terms** – FMCW radar, X-band, multipurpose radar, low cost, atmospheric monitoring, target detection, radar altimeter.

## I. INTRODUCTION

Frequency Modulated Continuous Wave (FMCW) radars have been always used in many applications, since both target range and speed can be detected analyzing the frequency spectrum of the received signal, using particular modulations, and adequate signal processing techniques.

The developed prototype of FMCW radar here presented is monostatic: it uses a single antenna to transmit radiofrequency signal and receive backscattered echoes. Single antenna operation could be achieved by using a circulator to isolate the transmitter from the receiver. Usually, the problem with this technique is that the circulator has limited isolation capability and forward energy may be reflected from the antenna and leak into the receiver path. The solution implemented in this prototypal radar exploits the possibility to switch the transmitter signal on and off. When the transmitter is off the receiver is switched on recording the received signal. A radar exploiting this technique is also called Frequency Modulated Interrupted Continuous Wave (FMICW). The effects of this gating are numerous and are well discussed in [1]. The most important ones for our applications are of course the reduction of the transmitted power, and the limitation

in range resolution due to the gating. However they do not heavily affect the desired performance for the system here described.

## II. HARDWARE DESCRIPTION

The prototypal FMICW radar hardware (Fig. 1) can be divided into different modules: synthesizer, power amplifier, receiver, filter, control unit, power supply and eventually the Oven Controlled Cristal Oscillator (OCXO). All of them are realized with electronic components as low cost as possible.

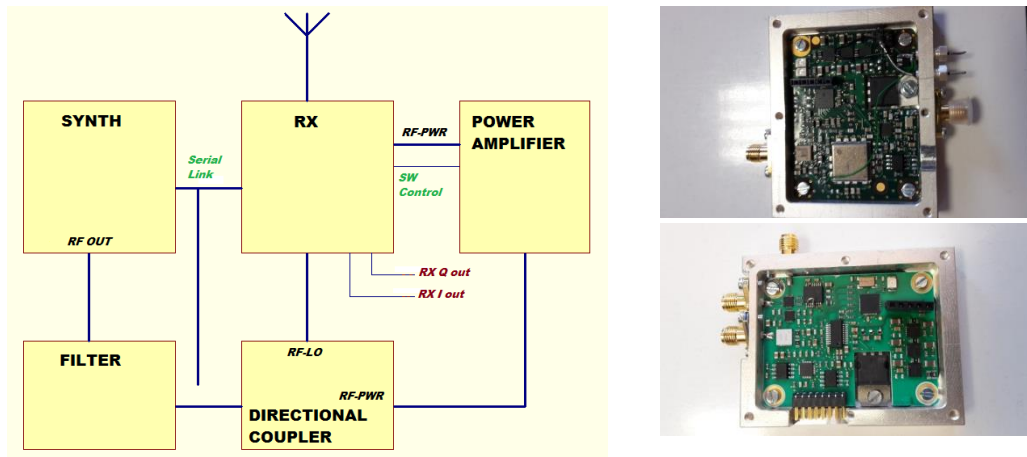

**FIG. 1** – FMICW radar electronics block scheme (left). Realized synthesizer and receiver modules (right)

The synthesizer is based onto an ADF4158 integrated circuit autonomously capable to produce FMCW signals with linear or parabolic ramp, tunable from 4700 to 4900 MHz, followed by a frequency doubler. This signal is then filtered and delivered to the receiver, for mixing operations and to the power amplifier.

The radar is equipped with 2D slotted array antenna with a Half Power Beam Width (HPBW) of 5 degrees which can be moved on the horizontal plane, keeping fixed the elevation.

The receiver module includes a low loss antenna switch operated by a 64 MHz microcontroller in order to operate as monostatic radar. The total noise figure is lower than 3 dB.

The LNA drives an active I/Q mixer which is followed by a dual channel variable gain amplifier. The acquired signal is then sent to the micro PC which acquires the signal using its own audio card properly programmed and then runs the control and processing software.

The control of the radar is done by a micro PC, model PIPO X7 running Windows 10© where the developed control software dialogs with the main microcontroller (MCU) of the radar. The MCU runs the ad-hoc developed firmware.

A power module produces all the voltages needed by the circuits, which are the stabilized  $\pm 5$  V and  $\pm 12$  V voltage.



**FIG. 2** – The realized prototype of multipurpose low cost FMICW radar.

### **III. CONTROL AND ACQUISITION/PROCESSING SOFTWARE**

It is possible to identify three different software sections: firmware, control and acquisition/processing software. The ad-hoc firmware is developed in embedded C and is resident on the MCU. The control and acquisition/processing software are developed in C# in a unique full package installed on the control PC. The control software allows users to properly program the prototype of FMICW radar to optimize the parameters (e.g. sweep time, bandwidth, transmitted frequency, etc.) needed to perform a specific operation. It sends the parameters to the radar exploiting the RS-232 interface. The control software package includes also the module to control the motion of the antenna. The acquisition/processing software allows acquiring the signal with the PC audio card and performing primary processing operations. It is possible to configure radar to act as target detection system by properly settings distance and power level thresholds, or weather radar by setting proper values for radar equations for meteorological target. Acquired data can be visualized and saved to file. As soon as the system is turns on, it can automatically start working for the desired and programmed application using the parameters stored in well formatted XML files.

### **IV. SOME EXPERIMENTAL RESULTS**

The first results aimed to test the radar proper working as a target detection system. At first a single corner reflector of known RCS was moved at different distance from the radar in order to verify the correct received power values (Fig. 3). A second test was then performed to show the radar resolution; according to theoretical calculation based on settled radar parameters, the FMICW radar resolution was 3.2 m, which was therefore the minimum distance at which the system can distinguish two different targets. The resolution was confirmed by experimental tests.

Other tests have been performed to verify the proper working as weather radar. Received power is converted into radar reflectivity factor and then into rain rate. Fig. 4 shows the comparisons between the rain rate measured by the FMICW radar (spatial resolution of 7.4 m) and an

extracted zoomed portion of a radar instantaneous map acquired by a calibrated X-band mini weather radar installed on the roof of the Politecnico di Torino. The reference track is highlighted in black. The FMICW radar underestimates rain with a bias of more than 5 dB. It means that further improvements and calibration procedures are required to use the radar as weather radar (adding also the automatic movement on the horizontal plane in order to obtain polar maps) or even a “microwave rain gauge” (the radar pointed in a single fixed direction).

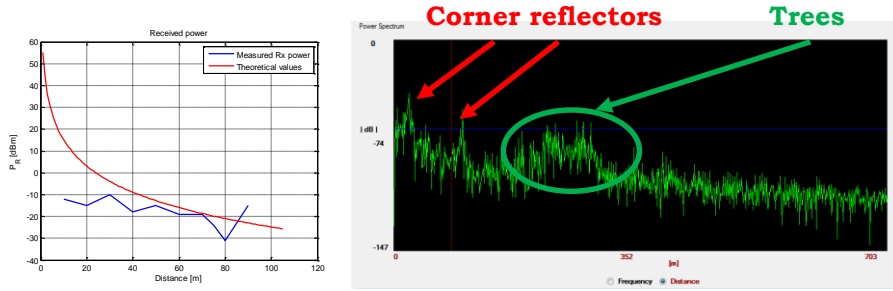

**FIG. 3** – Received power compared with theoretical values (left). Power spectrum acquired for radar resolution verification (right): first and second spikes are related to corner reflector. The peak power values before 350 m are related to trees at the end of the area where the tests were performed.

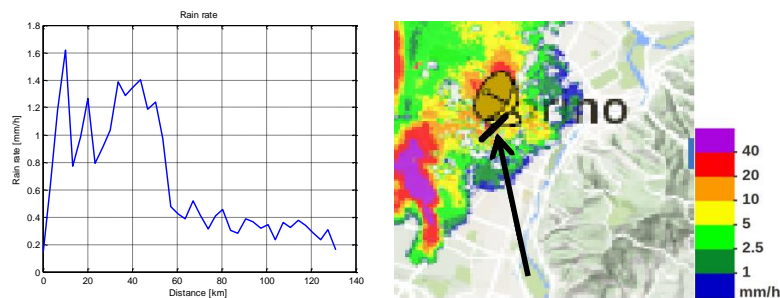

**FIG. 4** – Rain rate estimate with FMICW radar measurements (left) compared with zoomed portion of instantaneous radar map (right).

## V. CONCLUSIONS AND OUTLOOKS

The presented prototypal low cost and multipurpose FMICW radar shows good and encouraging results in different fields of applications. Future works will focus on improvement of radar performances for what concern both HW and SW. Main effort will be dedicated to use the system for atmospheric monitoring and meteorological purposes.

## REFERENCES

- [1] S. E. Hamran, T. Berger, L. Hanssen and M. J. Oyan, "Gated FMCW SAR system," *Proceedings of European Radar Conference (EuRAD)*, Amsterdam, 2008, pp. 487-490, doi: 10.1109/EUMC.2008.4751788.