

A Review of Numerical Simulation Strategies for Hydraulic Fracturing, Natural Fracture Reactivation and Induced Microseismicity Prediction

Original

A Review of Numerical Simulation Strategies for Hydraulic Fracturing, Natural Fracture Reactivation and Induced Microseismicity Prediction / Shahid, ARSHAD SHEHZAD AHMAD; Fokker, PETRUS ADRIANUS; Rocca, Vera. - In: THE OPEN PETROLEUM ENGINEERING JOURNAL. - ISSN 1874-8341. - ELETTRONICO. - 9:Suppl-1, M5(2016), pp. 72-91. [10.2174/1874834101609010072]

Availability:

This version is available at: 11583/2645817 since: 2016-07-29T13:40:00Z

Publisher:

Bentham Open

Published

DOI:10.2174/1874834101609010072

Terms of use:

This article is made available under terms and conditions as specified in the corresponding bibliographic description in the repository

Publisher copyright

(Article begins on next page)



The Open Petroleum Engineering Journal

Content list available at: www.benthamopen.com/TOPEJ/

DOI: 10.2174/1874834101609010072



REVIEW ARTICLE

A Review of Numerical Simulation Strategies for Hydraulic Fracturing, Natural Fracture Reactivation and Induced Microseismicity Prediction

A.S.A. Shahid¹, P.A. Fokker² and V. Rocca^{1,*}

¹Politecnico di Torino, Italy

²TNO, The Netherlands

Received: April 24, 2015

Revised: July 30, 2015

Accepted: August 12, 2015

Abstract: Hydraulic fracturing, natural fracture reactivation and resulting induced microseismicity are interconnected phenomena involved in shale gas exploitation. Due to their multi-physics and their complexity, deep understanding of these phenomena as well as their mutual interaction require the adoption of coupled mechanical and fluid flow approaches. Modeling these systems is a challenging procedure as the involved processes take place on different scales of space and also require adequate multidisciplinary knowledge. An extensive literature review is presented here to provide knowledge on the modeling approaches adopted for these coupled problems. The review is intended as a guide to select effective modeling approaches for problems of different complexity.

Keywords: Geomechanics, Hydraulic fracturing, Induced microseismicity, Shale.

1. INTRODUCTION

Shale gas reserves have become more and more important for the US energy mix and thus they have had a global impact. As it is well known, the very poor hydraulic properties of shales make the exploitation of these reservoirs uneconomical if produced conventionally. Only the activation of their natural fracture network and/or the opening of new fractures makes them economic [1]; if properly stimulated/generated *via* hydraulic fracture treatments, fractures become preferential flow channels for gas exploitation.

Hydraulic fracturing is a complex multi-physics phenomenon where fluid flow in the formation is fully coupled with the geomechanics of the reservoir rock. The efficiency of fracturing operations is strongly affected by the interaction with pre-existing natural fractures, which leads to more complex fracture geometries.

The mechanical and petrophysical (*i.e.* permeability) changes due to hydraulic fracturing occur deep in the subsurface and direct observation of all the processes is impossible. The only direct measurements of subsurface reservoirs come from the cores and the well logs, which provide very limited information about the reservoir. Well-testing and microseismic mapping may give good spatial information but these methods are indirect and contain lots of uncertainties due to a number of simplifying assumptions in the interpretation process. This incomplete set of information generates a need to develop an alternative workflow to obtain understanding of the physics involved and ultimately to optimize the hydraulic fracturing process. Various modeling approaches are used to study the system behavior using the limited information available.

Developing a representative model to simulate hydraulic fracturing is a challenging task as the coupled-physics processes involved take place on different spatial and temporal scales. An adequate model should give a realistic representation of the processes involved while keeping the computational cost within appropriate limits. Modeling

* Address correspondence to this author at the Politecnico di Torino, Italy; Tel: +390110907610; E-mail: vera.rocca@polito.it

approaches available in the industry range from simple standalone elasto-plastic correlations to complex multi-scale fluid-structure interaction (FSI) simulators.

The authors have not found a comprehensive review of existing techniques, strategies, advances, problems and ongoing research in numerical modeling for hydraulic fracturing and related phenomena like fracture reactivation and microseismicity for unconventional hydrocarbon resources. The present review has been compiled to fill that gap. In addition, it also deals with other geotechnical domains where hydraulic fracturing or fracture reactivation is used (like geothermal energy applications) if there can be a knowledge transfer with the domain of unconventional hydrocarbon resources. Indeed, if the relevant governing equations are the same and the boundary conditions are the same, the solutions provided for geotechnical applications will be valid for hydraulic fracturing as well.

As in any modeling effort, the quality of the input parameters is critical for the reliability of the model output. However, the procedures for determining these parameters are not discussed here. A large number of experimental and analytical studies are available that address the measurement of the required physical properties of the reservoir rock being modeled. In summary: indirect methods at well-scale and lab analysis at core scale. While the indirect methods usually lack in accuracy, they are able to address system heterogeneity. On the other hand, laboratory-scale experimental data can usually evaluate parameter values with a higher level of accuracy, but they must be subsequently extended at model scale. Moreover, compared to the intact rocks, fractures/faults samples are always disturbed and less representative of the real *in situ* conditions.

The paper starts with a brief overview of coupled geomechanical and fluid flow modeling schemes, followed by a basic geomechanical description of hydraulic fracturing and natural fracture behavior, as well as their applications. Then, different modeling workflows and simulation approaches for the phenomena under analysis are summarized and critically compared. This review is followed by a discussion of case-studies addressing simulations of interaction between natural fractures and hydraulic fractures. Finally, a concise survey on modeling setups developed to predict microseismicity in reservoirs undergoing fracturing or fracture reactivation is presented. The paper closes with observations about the suitability of the different schemes for different applications and under various circumstances.

2. BASICS ON HYDRAULIC FRACTURING, NATURAL FRACTURE REACTIVATION AND INDUCED SEISMICITY

The sweep efficiency of shale reservoirs is strongly affected by the extent and the continuity of the fracture networks induced *via* hydraulic fracture treatments. The presence of natural fractures leads to the development of complex fracture geometry, also with favorable effects on hydrocarbon production.

Natural fractures and faults can be viewed as a weakness plane in the rock which, on the one hand, reduces the mechanical strength of the overall rock mass and, on the other hand, alters the fluid flow characteristics. They are originated from different geological events such as regional and tectonic stresses, regional burial and local effects of major faults and folds. Over time, these discontinuities are sealed with minerals and locked due to, for example, frictional forces between the two fracture walls or fine migration, making them nearly impermeable to flow. If properly stimulated *via* hydraulic fracture treatments, natural fractures become preferential flow channels for gas exploitation. Furthermore, tensile failure induced by hydraulic fracturing stimulations can also lead to fracture propagation into intact rock and/or reactivation of existing fractures.

Hydraulic fracturing operations induce a stress state into the formation which exceeds the mechanical strength of the system: the induced failure can evolve both in tensile or in compressional mode with associated tensile or shear fracture generation, respectively. Fig. (1) shows the three possible fracture propagation modes.

When fluid pressure induces a tensile stress into intact rock that exceeds the minimum principal stress value, opening/tensile fractures start propagating perpendicular to the least principal stress direction (Mode I, Fig. 1a). The fluid pressure, the mechanical strength of the rock and the *in situ* stress state control the length and the direction of tensile fracture evolution. In normal faulting and strike-slip faulting regimes, these fractures are vertical because the minimum *in-situ* stress is oriented in horizontal direction. Furthermore, horizontal fractures are usually observed in shallow regions where the overburden weight is not predominant. In reverse faulting stress regimes or in shallow rock formations where the minimum *in-situ* stress can be in the vertical direction, a tensile fracture can be horizontal.

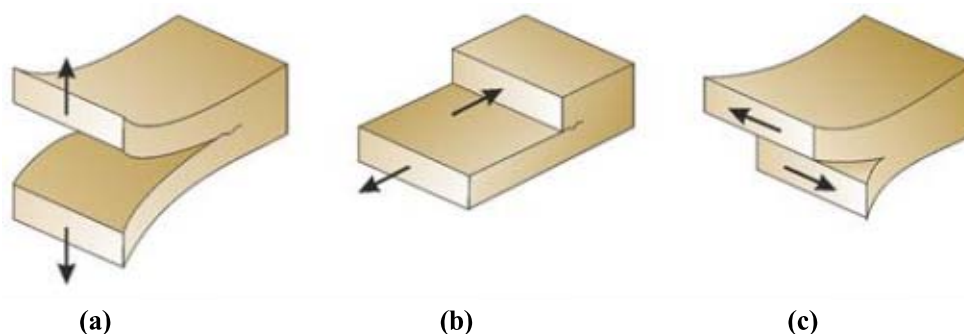

Fig. (1). Fracture Modes I (a) (left), II (b) (center) and III (c) (right) [2].

In a fracture/fault system, the presence of discontinuities or weakness planes affect the way the induced hydraulic fractures propagate. They can force the hydraulic fractures to deviate from the general propagation direction (direction of least resistance in case of tensile failure) and lead to extensive branching [3, 4], or they can arrest the hydraulic fracture at the point of interaction. Extensive technical literature [5 - 9] experimental studies and simulation analysis is available on the effects of pre-existing fractures on hydraulic fracturing evolution.

A microseismic event is a micro-earthquake resulting from hydraulic fracturing treatment when rock breaks and releases the energy in form of elastic waves that can propagate through the subsurface. Microseismic events can be generated whenever the rock breaks, as a result of induced fracturing or in case of reactivation of existing fractures. The induced microseismicity during hydraulic fracturing is mainly the result of shear failure (mode II) on existing natural fractures or induced hydraulic fractures.

Failure mechanisms of existing fractures are commonly represented by specific failure criteria conveniently selected according to the investigated scenarios [10]. If the shear stresses induced by the difference between principal stresses satisfy the failure criterion, natural fractures can be reactivated and slip along the fracture plane (Mode II, Fig. 1b). The onset of shear or sliding fracturing is controlled by the effective stresses and the failure criterion; the dynamics of the rupture process are controlled by the frictional behavior of the fault and the elasticity of the intact rock walls. The failure characteristics depend on fracture plane roughness and asperities that interlock the fracture planes making it difficult to slide against each other. Normal stress on the fracture planes press these planes against each other keeping them stable while the shear stress tends to shear the fracture. Once the acting stress increases to a level where it overcomes the resistance to sliding, the fracture reactivates. [11].

Mode III fractures (also called tear fractures) (Fig. 1c) also initiate because of an excess in shear stress and they propagate perpendicular to the maximum principle direction [12].

3. MODELING APPROACHES

Mechanical analysis can be developed at different scales and levels of integration with the other disciplines. Traditionally, rock mechanics has been included in conventional reservoir simulations by the adoption of a constant, or at most, pressure-dependent rock compressibility parameter [13]. In reality the effects of rock mechanics on fluid flow phenomena and *vice versa* can be much more complex: for example, the behavior of unconsolidated porous media, of critically stressed faults and of highly stress-sensitive rocks is strongly affected by the coupling effects. Furthermore, the rock mechanics and fluid flow coupling represents a principal factor for the phenomena involved in fault reactivation processes with associated transmissivity changes and induced seismicity, in high-pressure injection operations and in hydraulic fracturing activities. A deep insight of these systems/phenomena requires appropriately addressing the dependencies between fluid flow and stress-strain processes.

The key concept of coupled processes is based on Terzaghi's principle: a change in fluid pressure will change the effective stresses and cause the reservoir and the surrounding rocks to deform; conversely, the pressure field itself is also a function of the deformations and, hence, the coupling [14].

Stress affects the total pore space (and porosity, as well) with a consequent modification in pressure. Furthermore, porosity change results in a permeability variation, which again affects fluid flow behavior [15].

The degree of interaction between mechanics and fluid flow aspects is also a function of the loading condition and of the system deformation/strength characteristics. Consequently, the adopted simulation technique must be adequate to the complexity of the phenomena under analysis. In case of linearly elastic deformation behavior, for example, mechanical effects can be included in the reservoir simulation using appropriate position-dependent relationships to approximate pressure-dependent permeability and/or porosity changes. Hettema *et al.* [16] showed the importance of the stress path, which is defined as the change of stress induced by the change in pressure, and which can vary depending on the position in and around the reservoir. Settari *et al.* [17] presented different approaches to transfer stress-dependent parameters to pressure-dependent functions, which then can be used in conventional standalone reservoir simulators. A different situation evolves when linear elasticity does not apply anymore. For instance, if rock failure is reached due to mechanical loading, the changes in porosity and permeability will be much more pronounced and irreversible (plastic) and they cannot be properly addressed through linear relationships with pressure. In addition, while the change in porosity under elastic behavior is a linear relationship, models to describe those changes under plastic deformation are still a matter of debate. Mostly in these cases, the use of geomechanical modeling to better define the complete reservoir behavior is essential to fully define all the processes.

The technical literature shows several approaches to model formation behavior with different degrees of coupling between rock deformation and fluid flow. Most of the coupled modeling studies, published in the literature, deal with conventional reservoirs under compaction, wells reaching failure, seal-integrity and mechanical problems associated with injection and production. The following sections provide a brief overview of the techniques employed and the tools available currently.

3.1. Coupling Techniques

Different strategies were developed and successfully applied to solve coupled hydro-mechanical problems: fully-coupled, iteratively-coupling and one-way coupling.

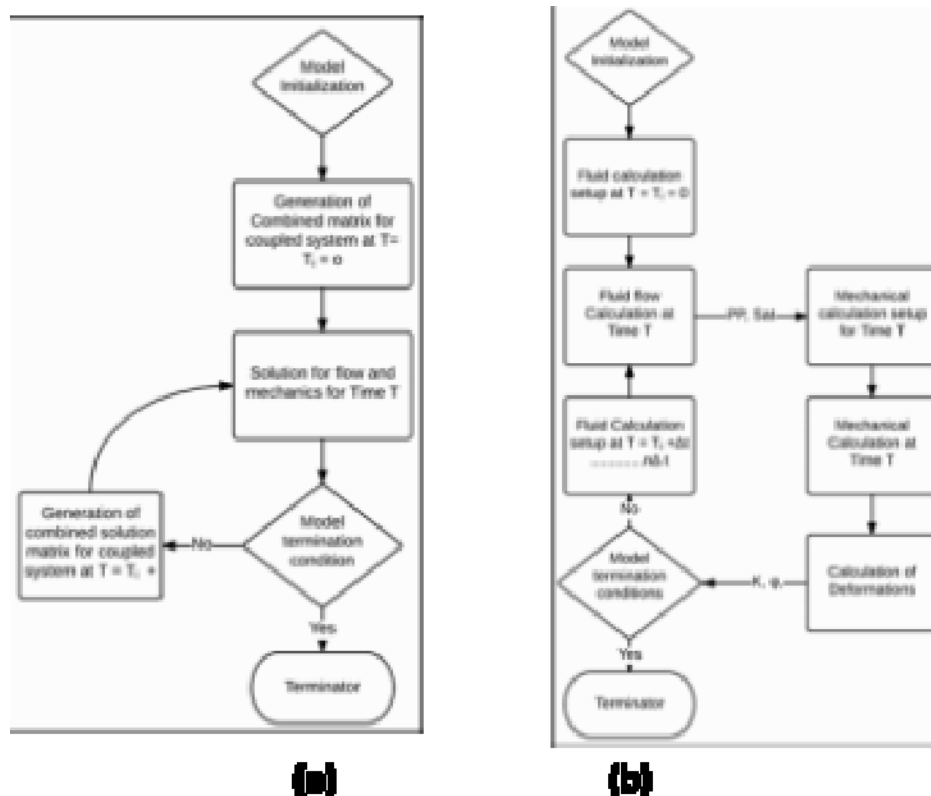

Fig. (2). Flow-chart for fully-coupled (a) and Iteratively-coupled (b) schemes.

The fully-coupled scheme, also called implicit coupling, performs multiphase flow and stress-strain calculation simultaneously solving one system of equations within a single numerical approach and the same spatial and temporal discretization. This approach has the advantage of internal consistency; it is also the most stable technique and

preserves second order convergence of nonlinear iterations. On the other hand, the fully-coupled scheme is the most demanding concerning computational time and numerical implementation.

Fig. (2a) shows the general flow-charts adopted in the fully-coupled scheme.

In the iteratively coupled approach, the basic equations for multiphase porous flow and rock deformation are solved separately and sequentially, and the calculation of coupling terms is iterated at each time step or after a preselected number of time-steps (Fig. 2b). The exchange of information between the reservoir simulator (generally developed according to the finite difference discretization method – FDM) and the geomechanics module (generally developed according to the finite element discretization method – FEM) is commonly handled through a transfer and conversion code, which also checks the convergence of the coupling iterations. The adopted convergence criterion is typically based on pressure or stress changes between the last two solution iterations [18]. The adopted coupling variables are usually related to the key reservoir characteristics in order to highlight the most important coupling phenomena, such as volume changes, stress-dependent permeability, saturation-dependent rock strength, *etc.*

The models developed by Rodrigues *et al.* [19] and Rustquist [20] are two examples of the modular philosophy where dedicated reservoir codes (such as IMEX by CMG® or TOUGH by Lawrence Berkeley National Laboratory) and dedicated geomechanics codes (such as FLAC/FLAC3D by Itasca®) are adopted to achieve the iteratively coupled scheme (Fig. 3).

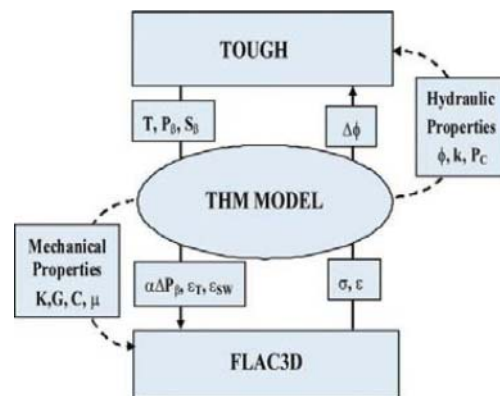

Fig. (3). Coupled modeling scheme, [20].

Dean *et al.* [21] and Jalali *et al.* [22] compared the fully and iteratively coupled techniques through a series of sensitivity analyses performed on simple case studies. Dean *et al.* [21] also analyzed different convergence criteria for the different coupling schemes and concluded that, if sufficiently tight convergence tolerances were adopted, the fully coupled approach and the iteratively coupled one provided the same results. If the correct convergence criterion is applied, an iteratively coupled method ensures loss of accuracy.

Finally, the one-way coupling approach allows the determination of the formation stress/strain change based on the pore pressure evolution calculated by the reservoir simulator. Yet the pressure field is supposed to be independent from the induced rock deformations: no strain-dependent variation of petrophysical parameters is incorporated into the reservoir simulator.

The higher the degree of coupling, the higher the need for computing time, technical skills and quality/quantity of input data, thus it is important to evaluate which degree of coupling is needed for each specific case, considering that different reservoir conditions and operational scenarios involve different levels of interaction between rock deformation and fluid flow. Alternative solutions may be taken into consideration such as the possibility to adopt sub-modeling techniques.

4. MODELING HYDRAULIC FRACTURING

There are a number of good overviews and general studies available on hydraulic fracturing [23 - 28]. The present paragraph briefly summarizes the most widespread theoretical models and the adopted numerical approaches.

4.1. Classical 2D, P3D and PL3D Models

Most modeling of hydraulic fracturing is based on the work of Sneddon [29] and Sneddon and Elliott [30] on crack opening, both for plane strain (2D) and for circular, penny-shaped cracks. Further evolutions and improvement of their theory were elaborated [31] until the formulation of the well-known PKN model [32]. The PKN model includes fluid loss effects and assumes an elliptical flow channel of which the width is determined by the frictional pressure drop. It is therefore appropriate for contained fractures with a large length / height ratio.

In 1955, Khristianovic and Zheltov [33] separately developed their hydraulic fracturing model, which was improved by Geertsma and de Klerk [34] into the KGD plane strain model. These models treat hydraulic stimulation as one single planar fracture that propagates starting from the wellbore away into the formation. The plane-strain approach makes the model applicable for cases where the length / height ratio is small and the fracture is initiated from a line source of perforations in the well.

Fig. (4) schematizes the fracture geometry of PKN, KGD and Sneddon's models.

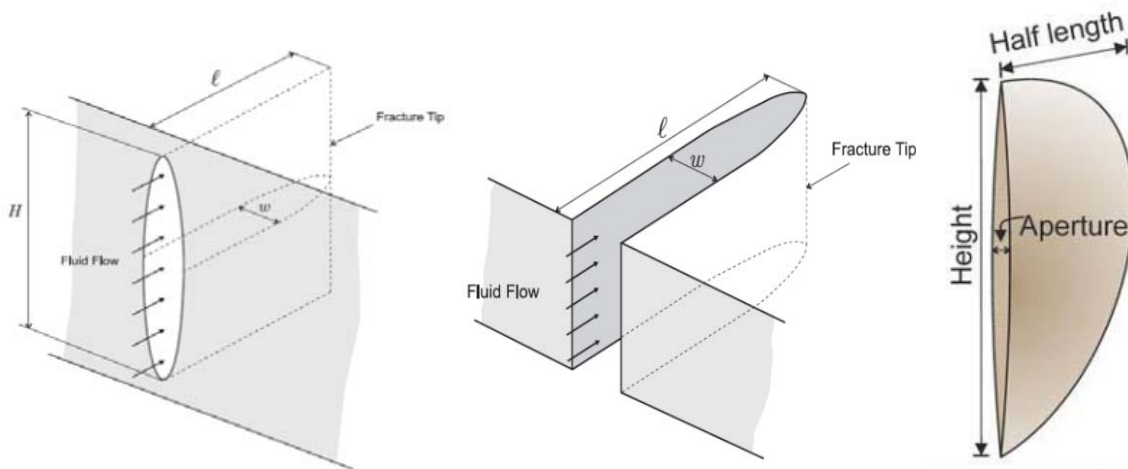

Fig. (4). Schematics of fracture geometry defined by PKN (left), KGD (middle) and Penny-shaped (right) [35].

Two types of 3D models were developed from these simple theoretical models: the pseudo-three-dimensional (P3D) and the planar-three-dimensional (PL3D) models. These extensions to the analytical models allowed to simulate hydraulic fracture propagation in multilayered reservoir rock system and were not restricted by fracture height [36].

P3D models are widely used in the industry for hydraulic fracture design to idealize fracture propagation in multilayered formations. P3D models modify the PKN (2D) model by considering fracture height in combination with fracture length and width. The added height variation of the fracture can be linear or parabolic [36].

In the PL3D modeling approach a plane is discretized at which fracture propagation can occur within a layered system. The final geometry of the induced fracture can thus be irregular, depending on the mechanical parameters of each layer. Fluid flow in the fracture is coupled with the reservoir rock elasticity and fracture propagation is controlled by the tensile strength of the rock. Fig. (5) shows the model of an induced hydraulic fracture in a multilayered reservoir using TerraFrac™, 2D finite element software based on the PL3D hydraulic fracturing approach.

P3D models can suffer numerical instability in case of systems with non-monotonically varying confining stresses in a layered system and also when there is unconfined height growth of fractures. PL3D models can handle these situations better [35].

To address the complex modeling requirements for hydraulic fracturing in unconventional reservoirs different numerical approaches and model discretizations have been employed. Depending on the modeling approach adopted by different authors these models can be divided into groups. The following subsections will discuss this.

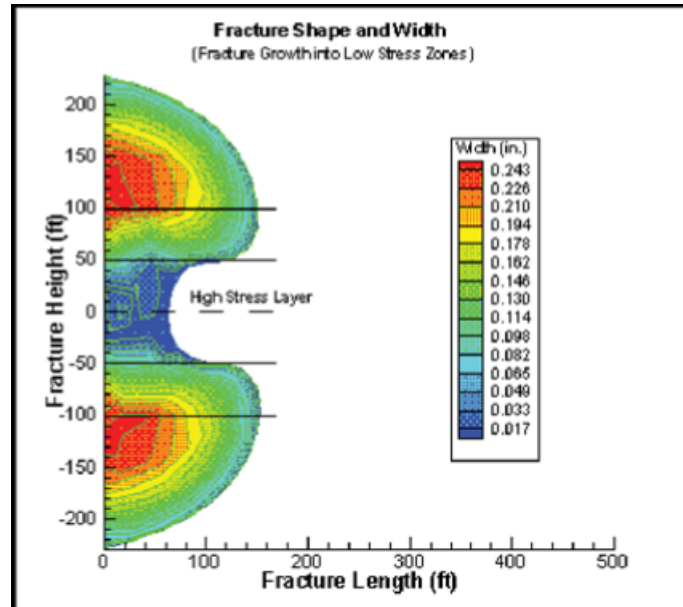

Fig. (5). Schematics of fracture geometry defined by PKN (left), KGD (middle) and Penny-shaped (right) [37].

4.1.1. Finite Element Method

In the finite element model (FEM) a reservoir system is discretized in subdomains (finite elements) of coded shape (typically tetrahedrons) using a mesh. On each element the solution is described by a linear combination of simple shape functions, usually polynomial, that locally approximate the global solution. One of the advantages of using FEM to simulate fracture propagation is that it allows to consider fractures that have complex 3D shapes that transcend the limitations of 1D or 2D models that have been used in the field for decades. Complex geometries with heterogeneous and anisotropic properties can be addressed. The fluid flow and geomechanical deformations are coupled based on Biot's poro-elastic theory [38, 39] and fracture propagation is modeled using linear elastic fracture mechanics (LEFM). Technical literature shows a number of applications of the FEM method to study the restriction of hydraulic fracture propagation by natural fractures and discontinuities [40, 41]. Fig. (6) shows hydraulic fracture initialization and propagation resulted from utilizing a finite element modeling approach.

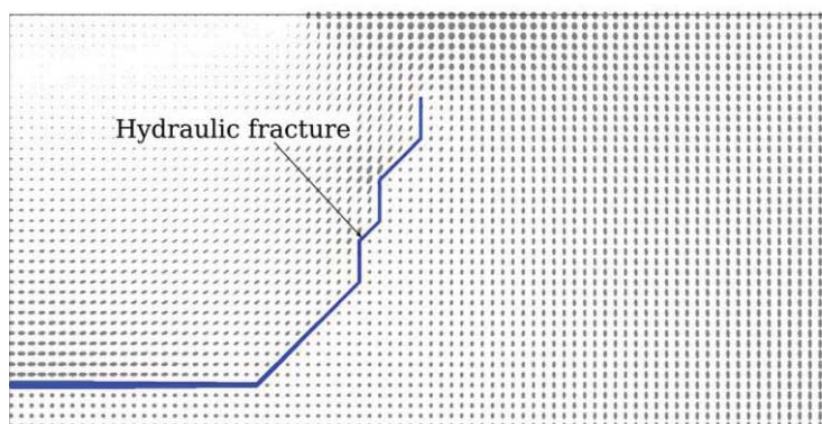

Fig. (6). FEM hydraulic fracture model [41].

Modeling fracture growth in FEM framework requires re-meshing of the reservoir grid that is intersected by a propagating hydraulic fracture. This re-meshing coupled with data translation, when two different numerical codes are involved (FEM for geomechanics simulation and FVM-Finite Volume Method and/or FDM-Finite Different Method for fluid-flow simulation), makes these FEM models computationally very expensive, especially in the case of complex fracture network geometries. To deal with this problem, the Extended Finite Element method (XFEM) was developed where induced fractures propagate without the need of re-meshing of the grid, under the assumption of small