

A Maximum Power Point Tracker of photovoltaic arrays for partial shading conditions

Original

A Maximum Power Point Tracker of photovoltaic arrays for partial shading conditions / Ahmad, Jawad; Ciocia, Alessandro; Spertino, Filippo. - STAMPA. - (2015), pp. 1-5. (2015 International Conference on Industrial Engineering and Operations Management (IEOM),) [10.1109/IEOM.2015.7228094].

Availability:

This version is available at: 11583/2645126 since: 2020-03-01T10:10:28Z

Publisher:

ieee

Published

DOI:10.1109/IEOM.2015.7228094

Terms of use:

This article is made available under terms and conditions as specified in the corresponding bibliographic description in the repository

Publisher copyright

(Article begins on next page)

A Maximum Power Point Tracker of Photovoltaic Arrays for Partial Shading Conditions

Jawad Ahmad, Alessandro Ciocia, Filippo Spertino

Energy Department, Politecnico di Torino

10129 Torino, Corso Duca degli Abruzzi, 24, Italy.

Abstract—The Power vs. Voltage (P - V) characteristic of a photovoltaic (PV) array is characterized by the presence of multiple maxima under partial shading conditions. Out of these only one is the global maximum. Conventional Maximum Power Point Tracking (MPPT) techniques may fail to track the global maximum which results in considerable power loss. Therefore, special MPPT techniques are adopted for MPP tracking of PV arrays under partial shading conditions. This paper proposes a technique which tracks the MPP of the array under partial shading conditions. In the proposed technique the PV array is disconnected from the load for a negligibly short period of time and is connected to an external capacitor. During the charging time of the capacitor, the proposed circuit tracks the global MPP. This circuit is easy to implement and shortens the time duration needed for scanning the P - V curve of the array.

Keywords- maximum power point tracking; partial shading; local maxima; global maxima

I. INTRODUCTION

Due to increasing energy crisis and environmental pollution, world's attention has diverted towards generation of electricity from renewable sources. Solar energy is one of the most important renewable sources because it is clean, inexhaustible and free. Photovoltaic (PV) arrays are used to directly convert solar energy into electrical energy. Solar arrays need low maintenance cost, have no rotating machinery, and the power conversion process is pollution-free. However, extraction of optimal power from PV arrays is quite challenging as the power vs. voltage (P - V) characteristic of the arrays is highly non-linear and changes constantly with the environmental temperature, irradiance, and shading conditions. Other problems with solar electric power generation are the high installation cost and low efficiency of solar cells. Considering these issues, it is very important to operate a PV array at a point where maximum power could be obtained. Maximum Power Point Trackers (MPPT) are used for this purpose. A variety of MPPT techniques have been reported in literature [1, 3]. These methods vary in their accuracy, cost of implementation, types of sensors required, ability to operate properly in shading conditions, and complexity of circuit etc.

Some of the well-known conventional MPPT techniques are: Perturb and Observe (P&O), Incremental Conductance (IC), Short-circuit current, Open-circuit voltage, and ripple correlation technique. These techniques are able to operate effectively under uniform irradiance conditions. Fig.1 shows the P - V curve of a solar array under uniform irradiance conditions which exhibits only one peak. Tracking of such a MPP is not quite challenging for conventional MPPT

algorithms like Perturb and Observe (P&O). The basic principle of P&O method is that the output voltage of the array is adjusted periodically and the output power from the array P_k is calculated. This value of power is compared with the value of power calculated in the previous perturbation step P_{k-1} . According to the sign of change in power, the direction of next perturbation of the array is determined. This process of perturbing the array output voltage and observing the output power is repeated until the MPP is reached. This is a simple technique and is adopted quite frequently for the PV systems in which all the modules in an array receive uniform solar irradiation.

For obtaining a desired level of power, solar arrays are formed by connecting multiple PV modules in series, parallel, and series-parallel configurations. With the increasing number of modules in an array, its physical size also increases. Due to its large physical size an array may not be under uniform irradiance and may suffer from partial shading which is usually caused by shadows of nearby buildings, trees, and dirt etc. This problem is almost inevitable under practical conditions. Out of 1000 building integrated PV systems installed in Germany, 41% suffered from partial shading [2]. Under these conditions, if a module in the PV array receives less illumination, the shaded module will dissipate some of the power produced by the rest of the modules. It means that current produced in the series connected array is limited by current of the shaded module. Also the dissipation of power in shaded modules may lead to local overheating and hot spot problems. When the hot spots exceed the maximum power that can be sustained by PV cells, it will cause irreversible damage. To mitigate this problem, bypass diode is connected across each module in the PV array. This method allows the array current to flow in the correct direction even if some of the modules are completely shaded.

However, another problem arises in electrical characteristic of PV array when bypass diodes are used. Because of the action of these diodes multiple maxima appear in the P - V curve of a solar array during non-uniform irradiance as shown in Fig. 2. The presence of these multiple maxima due to partial shading is a real impediment to the proper utilization of a MPPT. For conventional MPPT techniques like P&O all the maxima shown in Fig. 2 satisfy the condition of MPP. If the operating point tracked by the conventional technique is a local maximum, the output power from the array is significantly reduced. It has been reported in literature that the power loss due to the tracking of a local maxima could be as high as 70%

[11]. Hence, conventional MPPT techniques do not operate properly under partial shading conditions.

In the recent years, many studies have been performed for reducing the losses in PV systems due to partial shading. As a result of these studies, many MPPTs have been proposed for non-uniform irradiance conditions. These techniques are broadly classified as hardware based and software based. Hardware based techniques include module integrated DC-DC converters, multilevel converters, parallel connected MPPTs, and power electronic equalizers etc. [6]. Software based techniques include Fibonacci search algorithm, artificial neural network based, Fuzzy logic based, and particle swarm optimization based MPPTs etc. [8]. Hardware based MPPTs have the disadvantage of decreased reliability and efficiency, and increased system complexity and implementation cost. Software based techniques usually exhibit algorithmic complexity and may require powerful microcontrollers which naturally result in increased system cost [8]. Up to now the experts have not been able to reach a general consensus about the effectiveness of a particular MPPT for partially shaded solar arrays.

For tracking of Global Maximum Power Point (GMPP) during partial shading a periodic scan sequence of the P - V curve is frequently employed [2]. Due to long time required for the completion of this process, the production of energy from the array is reduced. Based on comprehensive study of the P - V characteristics of partially shaded arrays, [16] has proposed a technique which is capable of tracking the Global Maximum Power Point (GMPP) of a PV array under non uniform irradiance conditions. Even though the MPPT technique does not require scanning the entire P - V curve, [17] has shown that the time required to perform such a scanning can be as high as 8.6s. The MPPT algorithm proposed in [17] takes about 1.1s to track the GMPP which is also a long time. During the GMPP tracking the PV array is not operated at the MPP which causes a considerable power loss.

In this paper is proposed a MPPT which tracks the GMPP of a partially shaded PV array in a few milliseconds. During the scanning process PV array is disconnected from load and is connected to a completely discharged capacitor. During charging time of the capacitor, voltage of the array corresponding to MPP is measured and is kept in a droopless sample and hold (S&H) circuit for the operation of the MPPT algorithm. During scanning of P - V curve, power supply from the array to the load is disconnected for negligibly short period of time. The proposed circuit does not require complex computation and is easy to implement. The circuit is able to operate successfully under uniform as well as partial shading condition. The proposed technique is ideally suited for PV arrays of small or medium physical dimensions, in which we can neglect the effect of stray inductance or capacitances discussed in [10].

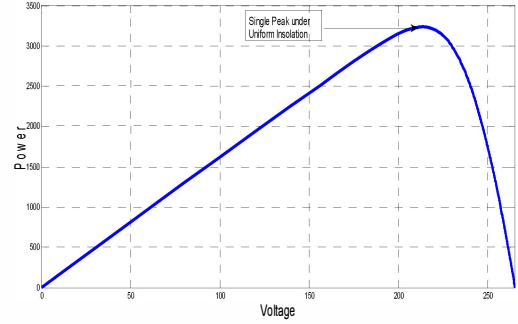

Fig. 1 P - V Characteristic of solar array under uniform insolation

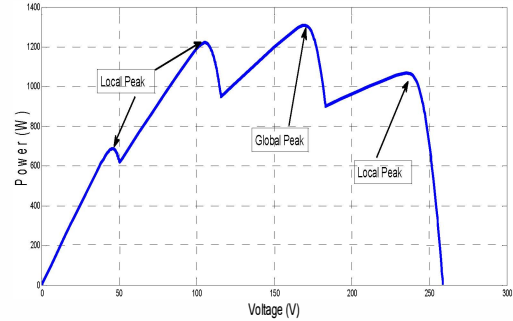

Fig. 2 P - V Characteristics of solar array under partial shading conditions

II. PROPOSED MPPT

Due to the charging characteristics of capacitor, its resistance changes from zero to infinity during charging. This characteristic of capacitor is utilized for obtaining the P - V curve of a solar array. The charging time of the charging capacitor t_c is given by [4, 9]:

$$t_c = 2C \frac{V_{oc}}{I_{sc}} \quad (1)$$

where I_{sc} is the short circuit current, V_{oc} is open circuit voltage of the array, and C is the capacitance of the charging capacitor. Ref [9] has proposed capacitor charging based MPPT but has failed to address some of the issues pertaining to the practical implementation of the MPPT algorithm. The value of C in (1) is chosen for the values of I_{sc} corresponding to low irradiance conditions, usually 200W/m^2 ; and a fixed duration of t_c , usually a few milliseconds. However, in the event of uniform and full irradiance there is manifold increase in the value of I_{sc} and the capacitor will be charged very quickly. In that event the measurement speed of MPPT system becomes important. This issue is addressed in this paper by using a S&H with a short acquisition time.

In Fig. 3 is shown the proposed MPPT Circuit. Switch S1 is used to separate the DC-DC converter from the PV array for scanning of its P - V curve, S3 is used to discharge the capacitor C_{charge} after the scanning is completed [9]. During scanning S1 and S3 are open whereas S2 is closed. Current through the charging capacitor is measured with a Hall Effect

sensor, R1 represents the internal resistance of the sensor. R2 and R3 are used for voltage division of the capacitor charging voltage during scanning. R2 and R3 have large values so that they draw a negligible current during the charging of capacitor. R4 is a relatively small resistor and is used to discharge the capacitor after the scanning is completed. The capacitor's charging voltage and current are multiplied by analog multiplier and its output is fed to a peak detector. When peak value at output of the multiplier is detected the peak detector triggers the Sample and Hold (S&H) circuit into sample mode for $5\mu\text{s}$ and the corresponding voltage is held [7]. Low frequency pulse generator described in [13] is responsible for controlling the duration of the PV array scanning and the time interval between two successive scanings of the array.

A short acquisition time of S&H is very important for determining accurate value of MPP voltage during uniform and full irradiance conditions. Also, the duration between two successive scanings of the array is long, typically 15-25s as reported in [5], it is important to maintain a droopless operation during this period. For this purpose, an infinite S&H is utilized in the circuit [14]. In the proposed circuit voltage corresponding to MPP is first converted to digital form using an on-chip analog to digital converter (ADC). This data is restored to analog form using digital to analog converter (DAC) on the same chip. This scheme has a number of advantages over traditional S&H which stores the held value on a hold capacitor. Firstly, because the stored value is recreated using a DAC, the circuit does not suffer from any droop problems associated with storing voltages on a hold capacitor for relatively long periods of time. Secondly, both the purposes of short acquisition time and zero droop rate are achieved which is not possible with the traditional scheme. After scanning the P-V curve, voltage corresponding to MPP is held by S&H as V_{Ref} . The pulse width modulation circuit compares the array voltage with V_{Ref} and adjusts the duty cycle of DC-DC converter to operate the PV array at its MPP [12].

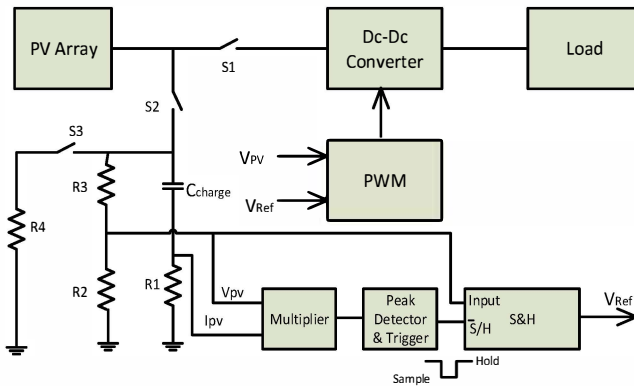

Fig. 3 Simplified diagram of the proposed MPPT

III. SIMULATION RESULTS

Simulations were performed to check the operation the proposed MPPT using Proteus software [15]. Programmable DC power supply with series resistance was used as 'solar array simulator' for checking the performance of the circuit [18]. This approach was preferred in order to introduce a desirable number of peaks in the $P-V$ curve. Each of Figs. 4, 5, and 6 show the following quantities during the simulation:

1. Output of the multiplier. This gives the value of PV array's power during the scanning of its $P-V$ curve. This value is monitored by the peak detector and it triggers the S&H in sampling mode when peak value of power is detected.
2. Output of the S&H which is the voltage corresponding to MPP and is utilized by the PWM controller as V_{Ref} .
3. Fraction of voltage across the charging capacitor during the scanning of the PV curve.
4. Signal at the control pin of S&H. As discussed previously, when the peak detector detects a peak at the output of the multiplier, this signal goes low which triggers the S&H into sampling mode to sample and hold the voltage corresponding to that peak.

Even though the acquisition time of the S&H is about $5\mu\text{s}$, in the simulations a pulse of a larger duration at the control pin of S&H has been shown for clarity of the results. As a result of it, the circuit may track a slightly higher value than the actual value of the MPP voltage during simulations. Fig. 4 shows the acquisition of V_{Ref} in case of single maxima on the $P-V$ curve, this corresponds to uniform irradiance conditions. As is evident from the Fig., the circuit is able to track the unique maxima on the $P-V$ curve under uniform insolation. The circuit in this case acts like a conventional MPPT as it is able to track the voltage corresponding to the unique power peak.

Simulations were performed to check the performance of the proposed circuit during the presence of multiple maxima due to different partial shading patterns. For introducing multiple maxima in the $P-V$ curve, piecewise linear power supply source was used. Fig. 5 shows the case in which two maxima are present on the $P-V$ curve i.e. at the output of the multiplier. As can be seen, the algorithm first tracks a local peak but when a GMPP is encountered, voltage corresponding to that peak is sampled and held by S&H. The figure indicates that after tracking of a local maximum, the circuit is not trapped at that point but tracks the global maximum when it is observed later during the scanning. Fig. 6 shows the case when a GMPP is tracked, the circuit ignores a local maxima encountered subsequently during the scanning. In Fig. 7 is shown the ability of the circuit to track the GMPP of a PV array in the presence of four maxima. It is obvious from the Fig. that the circuit is able to successfully track the true MPP of the PV array. This confirms the ability of the proposed MPPT circuit to operate correctly in the presence of any number of peaks that are present on the $P-V$ curve due to partial shading.

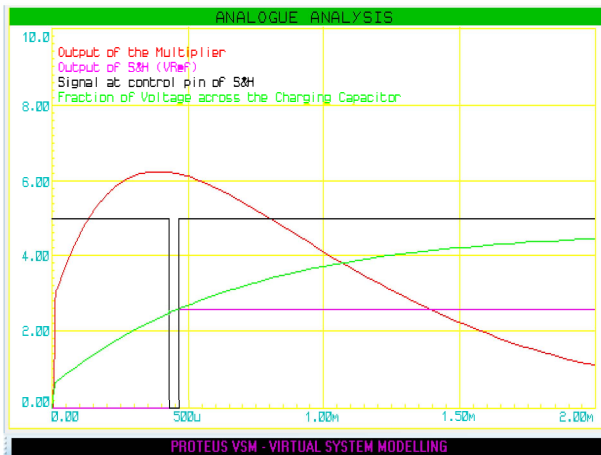

Fig. 4 Acquisition of V_{Ref} in case of a single peak

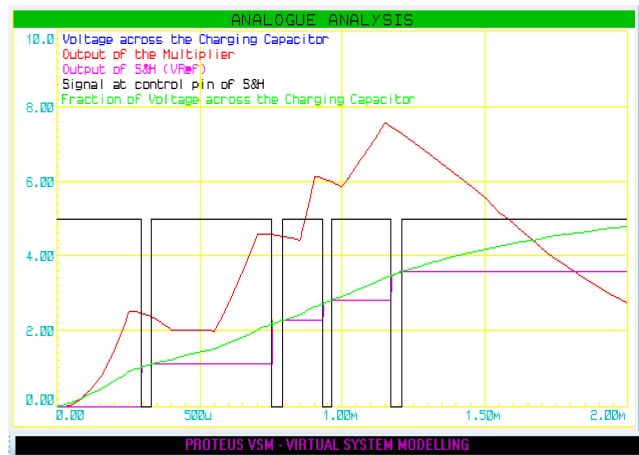

Fig. 7 MPP tracking in the presence of four peaks in the P-V characteristics

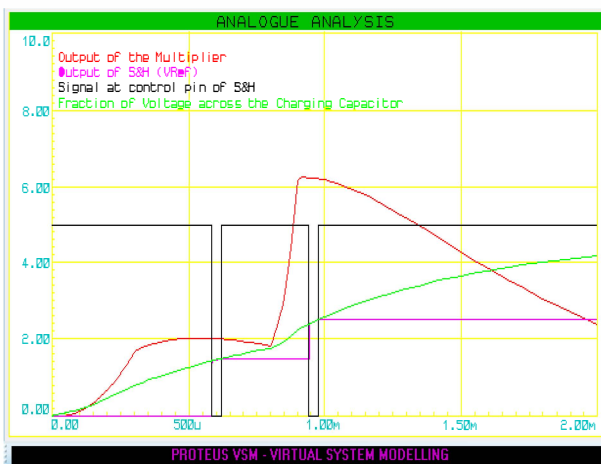

Fig. 5 Acquisition of V_{Ref} in case of presence of multiple maxima, first a local maxima is tracked but when a global peak is encountered, voltage corresponding to that peak is sampled and held

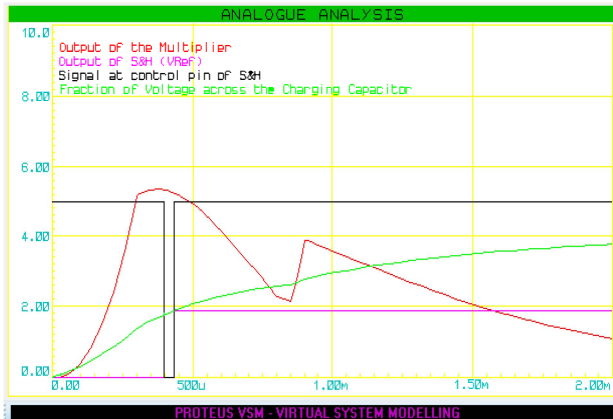

Fig. 6 Acquisition of V_{Ref} in case of two maxima, after tracking GMPP any subsequent local peak is ignored

IV. CONCLUSION

The $P-V$ characteristic of a solar array under uniform irradiance conditions has a single peak. Conventional MPPT techniques are able to track the unique MPP efficiently. On the other hand, the $P-V$ characteristic of an array under partial shading conditions exhibits multiple maxima. Out of these maxima there is only one global MPP. Conventional techniques fail to track this global peak which results in a considerable power loss. Therefore special MPPT techniques are adopted for PV arrays under partial shading conditions. In this paper a MPPT for photovoltaic arrays under partial shading condition is proposed. Periodic scan sequence of a PV array during partial shading condition is employed for tracking of GMPP. Such a scan may last for longer duration of time. During scanning the array is not operated at the MPP which causes a loss in the output power from the PV system. The proposed MPPT circuit aims to reduce the time duration required for scanning the $P-V$ curve of the array. For tracking of GMPP the array is disconnected from the load for a few milliseconds and is connected to an external capacitor. During the charging time of the capacitor, voltage corresponding to the MPP of the array is tracked and is kept in a droopless sample and hold circuit for the operation of the MPPT algorithm. The circuit is also easy to implement as it does not require complex computation. Simulations are performed using Proteus software. The performance of the circuit during uniform irradiance as well as different shading patterns has been confirmed through simulations.

REFERENCES

- [1] Esram, T., Chapman, P.L., "Comparison of photovoltaic array maximum power point tracking techniques," IEEE Transaction on Energy Conversion 22 (2), 2007, PP. 439-449.
- [2] Koutroulis, E. "A new technique for tracking the global maximum power point of PV arrays under partial shading conditions," IEEE Journal of Photovoltaics, Volume 2, Issue 2, April 2012, PP. 184-190.

- [3] M. A. G. Brito, L. Galotto, L. P. Sampaio, G. A. Melo, and C. A. Canesin, "Evaluation of the main MPPT techniques for photovoltaic applications," *IEEE Trans. Ind. Electron.*, vol. 60, no. 3, pp. 1156–1167, Mar. 2013.
- [4] M. M. Mahmoud, "Transient analysis of a PV power generator charging a capacitor for measurement of the I-V characteristics," *Renewable Energy* vol. 31, pp.2198-2206, 2006.
- [5] Bekker, B., Beukes, H. J., "Finding an optimal PV panel maximum power point tracking method," 7th A FRICON Conference, 2004, vol. 2, pp. 1125-1129
- [6] Mutlu Boztepe, Francese Guinjoan, Guillermo Velasco-Quesada, Santiago Silvestre, Aissa Chouder, and Engin Karatepe, "Global MPPT scheme for photovoltaic string inverter based on restricted voltage window search algorithm," *IEEE Transactions on Industrial Electronics*, vol. 61, Issue 7, pp. 3302-3312, 2014.
- [7] Yingying Kuai, S. Yuvarajan, "An electronic load for testing photovoltaic panels," *Journal of Power Sources*, vol. 154, Issue 1, pp. 308-13, 2006.
- [8] Ali Murtaza, Marcello Chiaberge, Filippo Spertino, Diego Boero, Mirko De Giuseppe, "A maximum power point tracking technique based on bypass diode mechanism for PV arrays under partial shading," *Energy and Buildings*, vol. 73, pp. 13-25, 2014.
- [9] Parlak, K. S., Hayrettin Can, "A new MPPT Method for PV array under partially shaded conditions," 3rd IEEE Symposium on Power Electronics for Distributed Generation Systems, pp. 437-441, 2012.
- [10] Spertino, F., Sumaili, J., Andrei, H., Chicco, G., "PV module parameter characterization from the transient charge of an external capacitor," *IEEE Journal of Photovoltaics*, vol. 3, Issue 4, pp. 1325-33, 2013.
- [11] G. Petrone, G. Spagnuolo, R. Teodorescu, M. Vitelli, "Reliability issues in photovoltaic power processing systems", *IEEE Transactions on Industrial Electronics*, Vol. 55, No. 7, pp. 2569-2580, July 2008.
- [12] Ahmad, J., "A fractional open circuit voltage based maximum power point tracker for photovoltaic arrays," 2nd IEEE International Conference on Software Technology and Engineering, vol. 1, pp. 247-251, 2010.
- [13] Linear Technology LTC6991, Resettable Low Frequency Oscillator, datasheet available at:
<http://www.linear.com/product/LTC6991>
- [14] Mike Byrne, "Implement infinite sample and hold circuits using analog input/output ports," *Analog Devices Application Note AN-284*.
- [15] Cui Yan ; Yao Wen ; Luo Jinzhao ; Bai Jingjing, "PROTEUS-based simulation platform to study the photovoltaic cell model under partially shaded conditions," *Electric Information and Control Engineering (ICEICE)*, 2011 International Conference on , pp. 3446 – 3449.
- [16] H. Patel, V. Agarwal, "Maximum power point tracking scheme for PV systems operating under partially shaded conditions," *IEEE Transactions on Industrial Electronics*, vol. 55, Issue 4, pp. 1689-1698, 2008.
- [17] Kai Chen, Shulin Tian, Yuhua Cheng, Libing Bai, "An improved MPPT controller for photovoltaic system under partial shading conditions," *IEEE Transactions on Sustainable Energy*, Vol. 5, No. 3, July 2014, pp. 978-985.
- [18] A.K. Mukerjee, Nivedita Dasgupta, "DC power supply used as photovoltaic simulator for testing MPPT algorithms," *Renewable Energy*, Vol 32, No. 4, pp. 587-592, 2007.