

POLITECNICO DI TORINO  
Repository ISTITUZIONALE

A European Platform for Distributed Real Time Modelling & Simulation of Emerging Electricity Systems

*Original*

A European Platform for Distributed Real Time Modelling & Simulation of Emerging Electricity Systems / Covrig, Catalin Felix; Santi, Giovanni De; Fulli, Gianluca; Maserà, Marcelo; Olariaga, Miguel; Bompard, ETTORE FRANCESCO; Chicco, Gianfranco; Estebasari, Abouzar; Huang, Tao; Pons, Enrico; Profumo, Francesco; Tenconi, Alberto; Doncker, Rik W. De; Grigull, Markus; Monti, Antonello; Stevic, Marija; Vogel, Steffen. - ELETTRONICO. - (2016). [10.2790/24617]

*Availability:*

This version is available at: 11583/2643562 since: 2020-01-22T09:00:45Z

*Publisher:*

Publications Office of the European Union

*Published*

DOI:10.2790/24617

*Terms of use:*

This article is made available under terms and conditions as specified in the corresponding bibliographic description in the repository

*Publisher copyright*

(Article begins on next page)

## JRC TECHNICAL REPORTS

# A European Platform for Distributed Real Time Modelling & Simulation of Emerging Electricity Systems

*A network of European labs for a science-based support of policy decision making toward future electricity systems*

**JRC-IET:**

Catalin Felix Covrig, Giovanni De Santi, Gianluca Fulli, Marcelo Masera, Miguel Olariaga

**Politecnico di Torino:**

Ettore Bompard, Gianfranco Chicco, Abouzar Estebarsari, Tao Huang, Enrico Pons, Francesco Profumo, Alberto Tenconi

**RWTH Aachen University:**

Rik W. De Doncker, Markus Grigull, Antonello Monti, Marija Stevic, Steffen Vogel

2016





# A European Platform for Distributed Real Time Modelling & Simulation of Emerging Electricity Systems

This publication is a Technical report by the Joint Research Centre, the European Commission's in-house science service. It aims to provide evidence-based scientific support to the European policy-making process. The scientific output expressed does not imply a policy position of the European Commission. Neither the European Commission nor any person acting on behalf of the Commission is responsible for the use which might be made of this publication.

**Contact information**

Name: Marcelo MASERA  
Address: Westerduinweg 3, 1755 LE, Petten, the Netherlands  
E-mail: [marcelo.masera@ec.europa.eu](mailto:marcelo.masera@ec.europa.eu)  
Tel.: +31 224 565403

**JRC Science Hub**

<https://ec.europa.eu/jrc>

JRC101772

EUR 27941 EN

ISBN 978-92-79-58545-6 (PDF)

ISSN 1831-9424 (online)

doi:10.2790/24617 (online)

© European Union, 2016

Reproduction is authorised provided the source is acknowledged.

All images © European Union 2016

How to cite: Authors; title; EUR; doi

## **Contributors**

### **Scientific Advisory Board**

Rik W. De Doncker, RWTH Aachen University, Germany

Giovanni De Santi, JRC-IET, Netherlands

Francesco Profumo, Politecnico di Torino, Italy

### **Coordinators**

Ettore Bompard, Politecnico di Torino, Italy

Marcelo Masera, JRC-IET, Netherlands

Antonello Monti, RWTH Aachen University, Germany

### **Research Team**

Gianfranco Chicco, Politecnico di Torino, Italy

Abouzar Estebarsari, Politecnico di Torino, Italy

Tao Huang, Politecnico di Torino, Italy

Enrico Pons, Politecnico di Torino, Italy

Alberto Tenconi, Politecnico di Torino, Italy

Markus Grigull, RWTH Aachen University, Germany

Marija Stevic, RWTH Aachen University, Germany

Steffen Vogel, RWTH Aachen University, Germany

Catalin Felix Covrig, JRC-IET, Netherlands

Gianluca Fulli, JRC-IET, Italy

Miguel Olariaga, JRC-IET, Italy

## Table of contents

Abstract .....	4
1. Introduction: European policies and emerging power systems .....	5
2. Open issues and challenges ahead .....	6
3. Real Time Simulation of Power Systems .....	10
1. Parallel and Distribution Simulation.....	10
Multi-Site Distributed Simulation .....	13
Time in Simulation .....	14
Parallel computation using real time simulators.....	15
Advantages and applications to power systems .....	15
Real time Simulation-Based Decision Support .....	17
4. European Real Time Integrated Co-Simulation Lab .....	18
1. Distributed real time co-simulation of power systems .....	20
Benefits.....	21
Challenges.....	21
Networking laboratories.....	22
Cloud solution for the interface and architecture .....	24
5. Demonstration of European 4-site Real Time Integrated Co-Simulation .....	26
1. Purpose.....	26
Co-simulation architecture .....	26
6. Trial Case: transmission – distribution systems interoperation for different weather and load conditions .....	32
Simulation scenario .....	32
Simulation models .....	32
Transmission network model.....	33
Distribution network model.....	34
Simulation results .....	37
7. Concluding remarks and steps ahead .....	42
References.....	43
List of figures .....	44
List of tables .....	45

## Abstract

This report presents the proposal for the constitution of a European platform consisting of the federation of real-time modelling and simulation facilities applied to the analysis of emerging electricity systems. Such a platform can be understood as a pan-European distributed laboratory aiming at making use of the best available relevant resources and knowledge for the sake of supporting industry and policy makers and conducting advanced scientific research. The report describes the need for such a platform, with reference to the current status of power systems; the state of the art of the relevant technologies; and the character and format that the platform might take.

This integrated distributed laboratory will facilitate the modelling, testing and assessment of power systems beyond the capacities of each single entity, enabling remote access to software and equipment anywhere in the EU, by establishing a real-time interconnection to the available facilities and capabilities within the Member States.

Such an infrastructure will support the remote testing of devices, enhance simulation capabilities for large multi-scale and multi-layer systems, while also achieving soft-sharing of expertise in a large knowledge-based virtual environment. Furthermore the platform should offer the possibility of keeping confidential all susceptible data/models/algorithms, enabling the participants to determine which specific data will be shared with other actors. This kind of simulation platform will benefit all actors that need to take decisions in the power system area. This includes national and local authorities, regulators, network operators and utilities, manufacturers, consumers/prosumers.

The federation of labs is created through real-time remote access to high-performance computing, data infrastructure and hardware and software components (electrical, electronic, ICT) assured by the interconnection of different labs with a server-cloud architecture where the local computers or machines interact with other labs through dedicated VPN (Virtual Private Network) over the GEANT network (the pan-European research and education network that interconnects Europe's National Research and Education Networks ). The local VPN servers bridge the local simulation platform at each site and the cloud ensuring the security of the data exchange while offering a better coordination of the communication and the multi-point connection. It is then possible the integration of the different sub-systems (distribution grid, transmission grid, generation, market, and consumer behaviour) with a holistic approach.

## 1. Introduction: European policies and emerging power systems

The EU is defining a new set of energy policies that will shape the evolution of energy systems and markets towards 2030 and 2050. The 2020 targets and the maturity of the Third Energy Package prescriptions promoted in the last decade profound changes at both the national and European levels. However, the interplays between many factors influencing those changes (among others, the massive introduction of renewable sources and the related incentives, the unbundling of operators, the setting up of the Emission Trading System, the increase of electricity flows across borders, and the technological modification towards smarter electricity systems,..) have not resulted in a balanced arrangement. As the system will continue this transformation in all its components (technologies, retail and wholesale markets, network codes, financial instruments, institutions), policy decision makers would require scientific support able to analyse and anticipate the effects and impacts of different measures.

The new 2030 Climate and Energy Framework was issued in January 2014. On the one hand, it called for the development of national energy action plans, which would have to present a coherent picture of the potential unfolding of the energy mix, the needed investments and the satisfaction of the CO<sub>2</sub> emission target. On the other hand, it fixed a RES goal at the European level, which should be satisfied by the conjoint efforts of the EU MS. Then, in 2015, the Commission presented the Energy Union initiative, with priorities on the supply security and the interconnectedness as a means for the full integration of the internal energy market.

The power system is drastically changing towards new schemes at two different levels. At the high voltage level, requirements for exploitation in a large-scale of cheaper and cleaner renewable energies such as hydro, nuclear, onshore /offshore windfarms, solar power in the desert, etc., are merging for the transmission network. The competition at this level for the economic efficiency is through the wholesale electricity markets with reflection into the retail markets at the distribution level. To achieve the main goals concerning energy, especially electricity, i.e. affordable and competitively priced, environmentally sustainable and secure for every citizen, a common recognition of establishing a well-integrated internal energy market at the EU level has been reached and progressed greatly from 2008 to 2014 [1].

Therefore, to support the unified European electricity markets, a backbone electricity transmission system across large distance is needed. Hence the super grid is forming gradually to accommodate this trend. In contrast, at the lower voltage level, the vast development and deployment of distributed generation, especially renewable ones, and the rapid increase of intelligent domestic appliance promote the needs for a smarter distribution system to emerge. To ease this trend and maximally activate the participation from electricity customers, several policies and political initiatives has been made. The “framework strategy for a resilient energy union with a forward-looking climate change policy” of the Energy Union package greatly encourages consumers to master the energy transition and actively participate the market to benefit from the economic point of view, especially under the scenarios of shifting the traditional roles to prosumers [2]. The “Delivering a new deal for energy consumers” even detailed the request and political framework to empower customers’ participation and contribution in the transient of the energy union. Therefore, the future electricity system is then a network of networks, in which large amount of local

distribution systems (smart grids) are connected by the intelligent transmission systems (super grids).

In addition, the provision of electricity depends on the decisions of several players (policy decision makers, regulators and their associations, system operators and their associations,...) in different fields (economic, technical, strategic,...) at multiple scales (local, national, regional,...) and with reference to various time frames (from real-time to long term). To be reliable, the system needs to be secure (with reference to the sources and the operation of the infrastructure), and adequate (with reference to energy conversion and electricity infrastructure). On the other hand, power systems can be vulnerable to threats that, when materialized, may cause foreseeable and unforeseeable disruptions.

From the perspective of the emerging regulatory regimes, there are bidirectional interplays between social aspects that provide goals, expectations, “rules to play”, etc., and technical structures that define physical functionalities, feasibilities and etc. Both micro-players and macro-players involved in the emerging system have to make decisions and react to changes of environment driven by others’ actions in order to fulfil their own roles. Multiple aspects, such as social and technical concerns, regulation and individual strategies, markets and their derivatives, coordination and self-organization of different players, determine the performance of the distribution system need to be studied ex-ante to devise, validate and assess the policies and decisions. Among the influential factors on smart distribution systems, the following are considered as most crucial: a robust and secure network to accommodate electricity needs for all participants, an advanced intelligent ICT infrastructure for monitor, communication and automatic control, market opportunities to enhance economic efficiency, policies at different levels to blueprint the shape of the future system.

From a societal perspective, the economy is shifting from a product-based approach to service-based one, more focused on the consumer as a beneficiary and selector of the most appropriate and cost-effective solutions among those offered. This trend will soon be affecting the electricity system. The transition to a service-economy requires, in general, and, in particular, in the electrical system, an open technological environment where more market players compete to provide services, where solutions are interoperable (avoiding dominant market positions tied to proprietary solutions), and innovative new services can be ready deployed without heavy barriers to entry/exit.

## **2. Open issues and challenges ahead**

Europe faces a crucial period regarding the development of energy systems and markets. In particular, the EU’s transition towards smarter electricity systems would require provision of highly qualified input to the European and national policy decision-making processes. This input will have to be based on solid scientific knowledge of the emerging systems, technologies and services. Therefore, a scientific research platform (referred below as the "Platform") pooling excellence from different European member states and institutes is proposed to build up the required solid scientific evidences.

In the EU there is a wide set of scientific expertise in the area of energy that can be exploited in a coordinated effort to support the EU policy decision making. The participation of the scientific community of academia and research institutions, in cooperation with the national stakeholders, will

provide additional expertise and widen its perspective with respect to the Commission, while directly involving the member states. This will result in a boost of confidence and sharing view of the European policy to be adopted.

The possibility of scientific cooperation between the EC, through JRC, and the Member States through leading, independent scientific institutions, is crucial and of mutual beneficial. The proposed platform will enable the study of different components, architectures and strategies (including economic, environmental and social factors); hardware devices (PV panels, storage components), network structures (topology sizing of wiring, transformers, levels of automation,...), information exchange systems and processes for communication and control (field data to control centers, market information from smart meters,...), network/market regulation and control, threats to security, etc.

The general objective of the Platform is the establishment of a pan-European networked laboratory on emerging grid technical evaluation and impact assessment. The specificity of the lab will be its focus on providing scientific support to business and policy decision making in the electricity sector. The Platform will be composed of a coordinated network of innovative experimental test-facilities, including software models and hardware components, necessary for the study of the emerging smart grids. The Platform will be devoted to providing an “in-vitro” distributed context in which existing and perspective available technologies and operational tools can be assessed in realistic settings.

The Platform will look at:

- “super grids”, the national, continental and trans-continental transmission system conveying the supplies from high capacity traditional or renewable-energy power plants,
- “smart grids”, the distribution systems with active users (prosumers), distributed generation and storage.

The testing/simulation in the lab can be implemented through “hardware” components directly tested or through “software” in terms of computer based simulation platform.

The Platform will include “hybrid” types of laboratories in the sense that the “node labs” will be equipped with either HW or SW-based testing and simulation facilities, and their combination. Some connections with real distribution systems test will be established to widen the testing capabilities.

The hardware and software testing/modelling capabilities will be distributed among the various participant labs, arranged both in terms of specific fields (communication testing, distributed generation devices, etc.) and operational procedures. The testing/assessing of policies, operations or technologies (i.e. the “experiments”) will be implemented by providing, in a coordinated manner, different tasks to different laboratories based on the same data sets, on a common model of the system under study, a common protocol for the measurement and common schemes for data collection. On this basis the results of the experiments undertaken “on the network” will result in a coherent set of results that can be assessed as a whole.

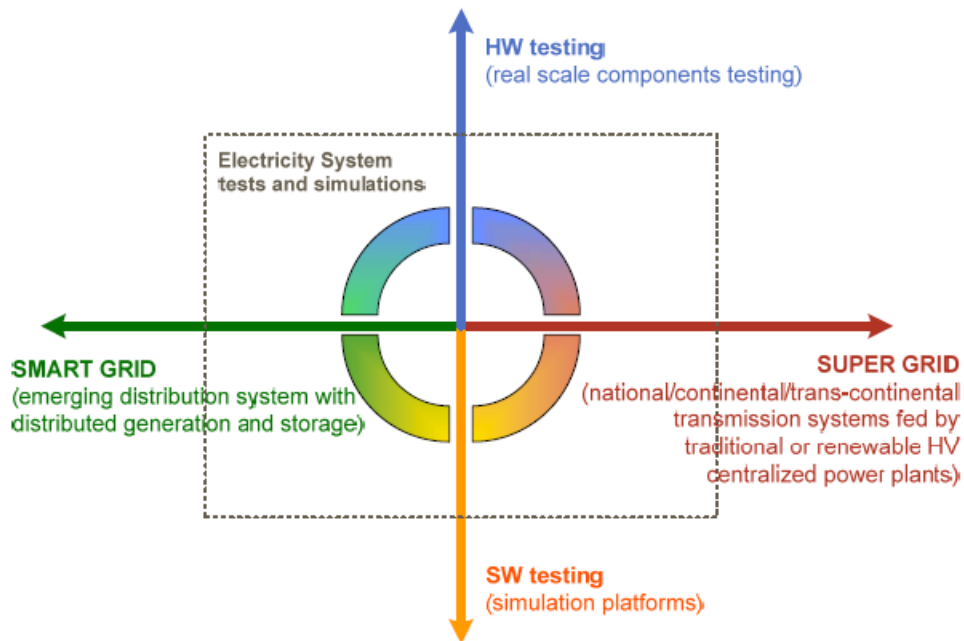

Figure 1 Representation of the scope of the Platform

Several challenges and open issues, besides technology development and deployment, can be identified in the transient of the electricity systems towards an emerging smarter one. The following points present some of the more pressing challenges:

- **Investment and resources**

It has been anticipated that the EU energy transition would require investments amounting to ca. 1 Trillion Euro. This poses challenging requirements both to the market conditions that would make those investments possible and to the technological development that would provide the solutions to implement. A crucial point for infrastructural investments is the possibility to take advantage of the European programmes (e.g. Trans-European Networks, Connecting Europe Facility) and of the Cohesion/Structural funds by each MS.

- **EU policies v.s. national implementation**

Energy policy was typically national based, weakly coordinated at the European level with main consideration of energy, as many other areas are like foreign affairs, more a national than communitarian business. The policy making of the EU, although unified, needs to be built in a strict connection and with the involvement of the member states to be effective and politically sustainable.

- **Security of supply**

The European energy union is evolving towards a more truly unified system and market, which are needed when energy is understood as a global problem both in terms of the procurement of energy resources and of the impacts deriving from those resources (e.g. climate change, global trade, etc.). The EU has a high level of dependency in terms of energy from several other countries (Russia, OPEC Countries) and competes with others for those resources (China). The costs due to energy imports are huge and represent a remarkable share of the unbalance between import/export. The effects of this situation threaten the EU both from the point of view of security and market competitiveness.

To possibly face those challenges in a globalized world requires a unified action at the EU level in all respects (forecast, management, research,...), with an active participation of the member states.

- **Scientific evidence needed for policy and business decision making**

Policy and business decision making is facing a complex world with many emerging opportunities, unknown and challenging (smart grids, bio-fuels, shale gas,...) and to be reasonably sure to provide appropriate answers to complex problems needs a strong scientific support.

- **Service innovation based on open platform vs. proprietary platform**

An environment for services and market innovation with a reference platform in the energy sector should follow an open approach based on services open to competitors and market innovation. The competition should be on services, and not on the creation of proprietary underpinning technologies. The environment should be interoperable and integrated into the wider landscape of non-energy services (transport, health, social services, etc.) in smart societies (from smart grids to smart cities). Thus a "pro-innovation" platform should be created which allows rapid and cheap tests and development of the solutions and services and certification of compatibility with the standard. The platform must be able to be used by different services providers (developers of services for end customers, DSO, marketers) that focus on different segments of the electricity system (the distribution network, the prosumer, the retail market, etc.); Also regulators and policy decision makers, which can and must put rules to the development of services, can benefit to estimate the effects of their decisions.

- **Competitions between EU and major players in the world**

A "standard" for the transition towards smarter grids and the related services should be seen as a competitive advantage for the EU. This is a global industrial field with fierce competition from America and Asia. The development of a solid European approach, including the relevant standards, should help EU companies in pre-empting their competitors.

### 3. Real Time Simulation of Power Systems

There are many different types of simulation tools for modelling and planning for power systems, from large-scale high voltage transmission systems to low voltage distribution grids or even small controllers or devices, for a variety of applications, from transient analysis to long-term planning. Nowadays in power systems, renewable energy sources as distributed generations are penetrating increasingly, more smart equipment, like smart metering infrastructures, are being utilized, the infrastructures are also growing in terms of complexity and interdependency, and the communication system used for information flow are also being extensively developed as well as operational methods. Therefore development of advanced management systems, either equipment or strategies, is vital for power networks.

However the deployment of new systems requires tests and validations before implementation: new equipment models should be tested before making any prototypes, or the physical prototypes should be replaced with virtual models in advance, and tested in a virtual environment or network model. This requires power network simulation as close as possible to the real world. New strategies (e.g. fault location algorithms, demand side management, etc.) should be also verified before applying them to the real world. To meet all these requirements, real time simulation of power systems seems inevitable. Real time simulation provides a virtual environment of the systems in which new control strategies or technologies can be tested ex-ante before implementing in the real world system providing trustable real-like information on impacts and benefits.

Real time simulation reproduces the behaviour of a physical system through running its computer-based model at the same rate as actual time. In power systems, real-time simulation aims at reproducing with accuracy the behaviour of the physical variables (e.g. voltages, currents, phases, etc). Real time simulation is typically used for reproducing the dynamics of fast phenomena, closed-loop testing of protection and control equipment, and generally all “what-if” analyses regarding transients.

One of the characteristics of real time simulation is its computation parallelism capability, in which different components of the model could be run assigned to different calculation cores. The calculation cores for simulating the model can be any of the following combinations: several cores of the same CPU, several CPUs of the same computer (calculation machine), computational cores of different computers in a local area interconnecting via Local Area Network (LAN), several computers distributed in distant geographic locations communicating through Wide Area Network (WAN). To better explain parallelism in real time simulation, parallel and distribution simulation is briefly introduced in the following sections.

#### Parallel and Distribution Simulation

Parallel or distributed simulation aims to reduce model execution time by using more processors, and provides the ability to run larger models since more memory and more computational power is available. In time critical decision making processes, like power system outage management or fault location, parallel and distribution simulations enable simulation to be used as a forecasting tool as it can be used for fast execution applications called “what-if” experimentation. Parallel and distributed simulation architectures provide also the best platform to perform real time simulations.

Contrary to parallel simulation, in sequential computing, the model is run on a single computer having a single CPU, while the problem is broken into a discrete series of instructions to be executed one after another, but only one instruction may execute at any moment in time (Figure 2).

Parallel computing is the simultaneous use of multiple compute resources to solve a computational problem, running on multiple CPUs. The problem is broken into discrete parts that can be solved concurrently, and each part is further broken down to a series of instructions. The instructions from each part then execute simultaneously on different CPUs. Multiple computer resources can be either a single computer with multiple processors, or multiple computers connected by network, or even a combination of both. The computation problem should be able to be broken apart into discrete tasks of work, which can be solved simultaneously. The program should be also able to be executed as multiple instructions at any moment in time, and is expected to be solved in less time with multiple compute resources than with a single compute resource. For example, total communication interconnection time must be taken into account in such a way that the total computation time decreases (Figure 3).

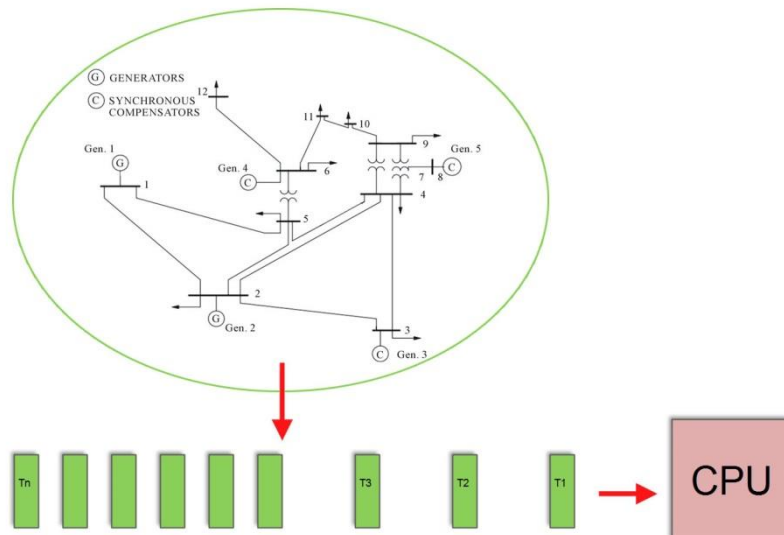

Figure 2 sequential computing

Distributed simulation (Figure 5) is a form of parallel simulation in which processors are coupled via Local Area Network (LAN) or Wide Area Network (WAN), while in centralized parallel simulation (Figure 4), coupled processors share memory in one computer.

There is another form of co-simulation in which several independent simulators execute simulations at the same time (“replicated trials”, shown in Figure 6). For example, user would like to simultaneously simulate the impact of changing some parameters on the same model using several processors.

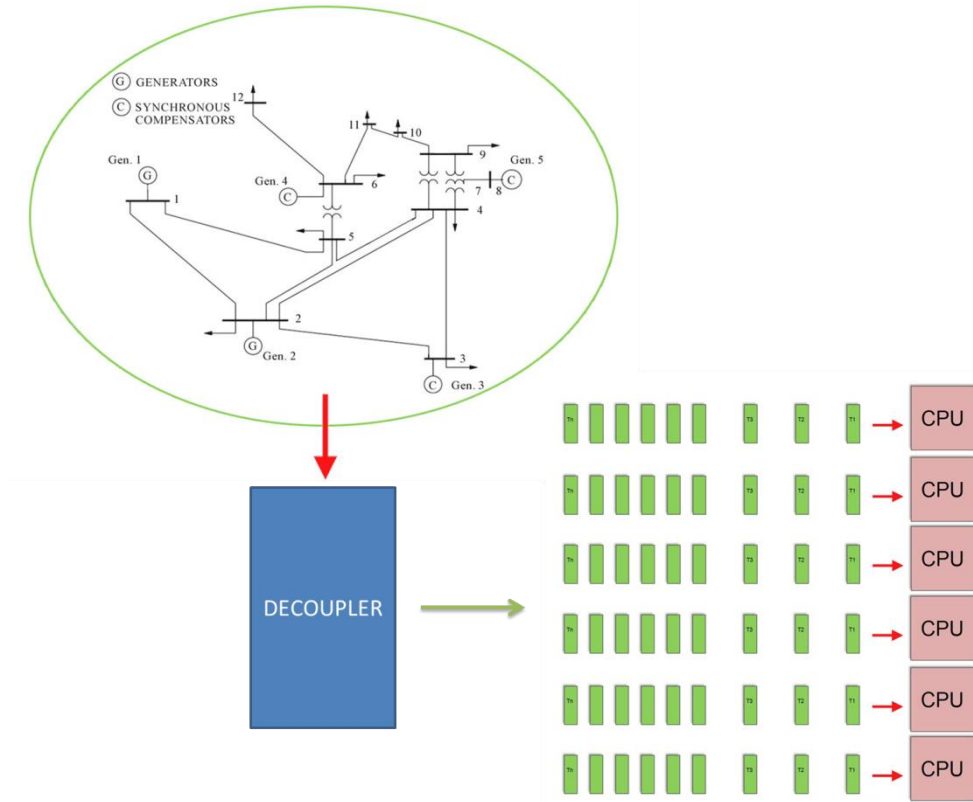

Figure 3 Parallel Computing

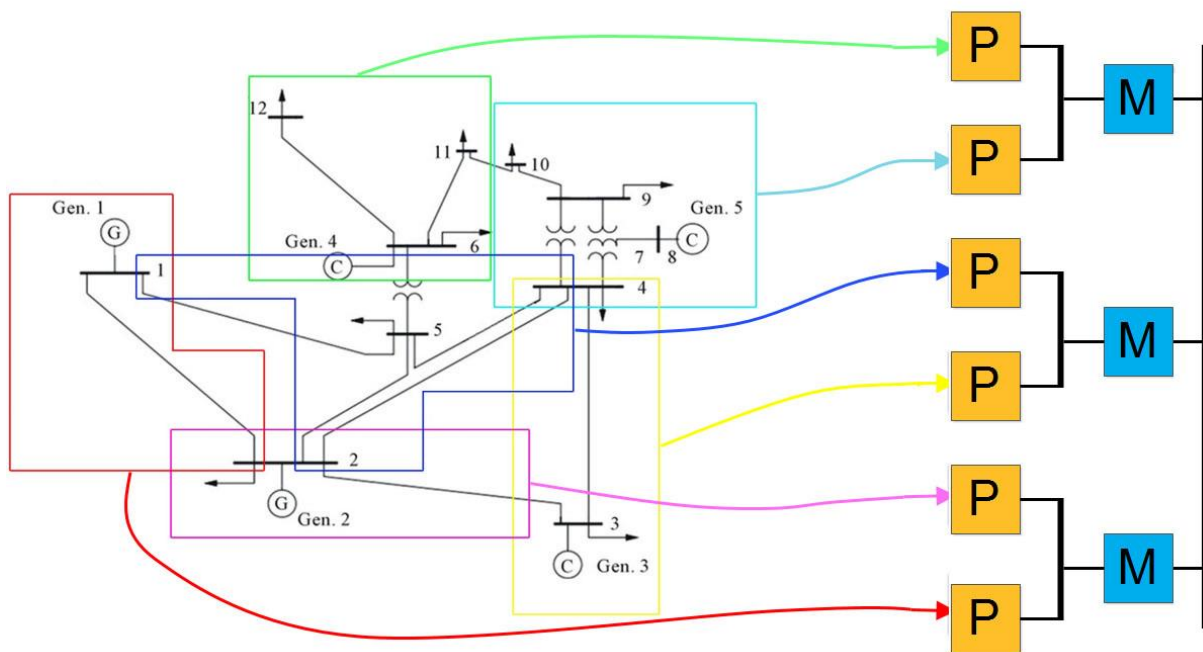

Figure 4 Parallel Simulation (M: Machine, P: Processor)

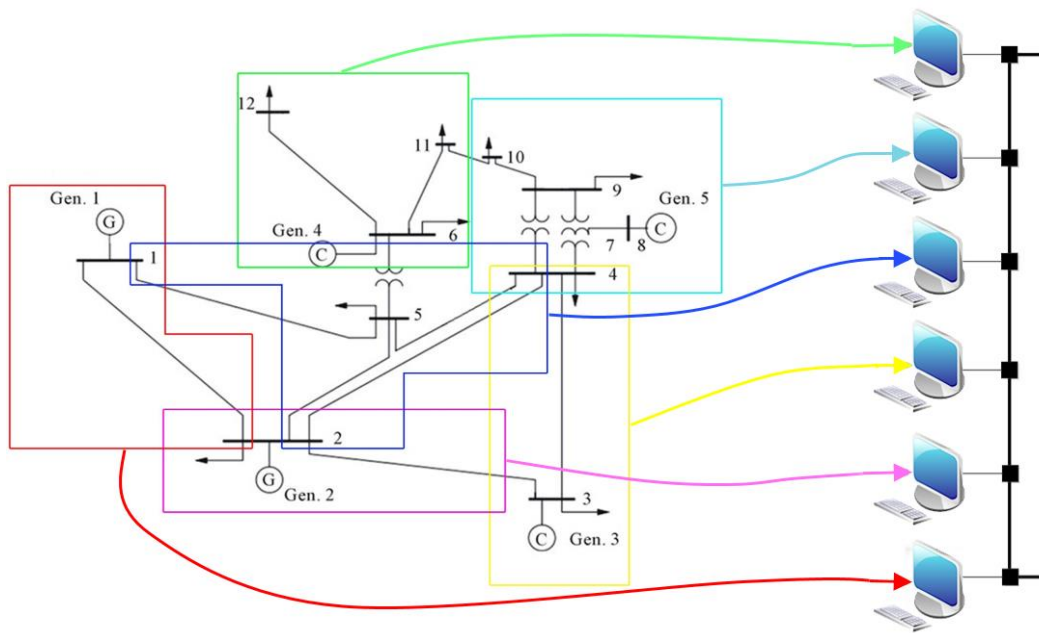

Figure 5 Distributed simulation

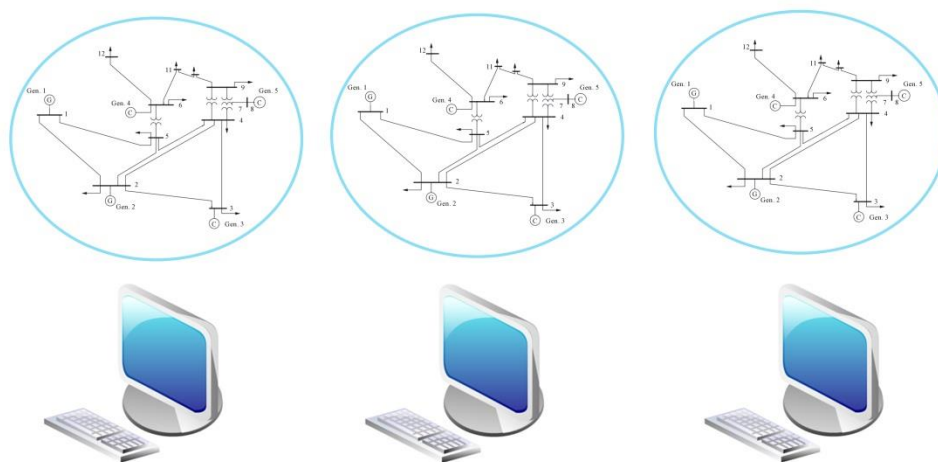

Figure 6 Replicated trials

### Multi-Site Distributed Simulation

One of the main advantages of parallel and distributed simulation is to create distributed virtual environment in which different users or computers multi-site located in different labs (e.g. located in different cities, countries, etc.) concurrently execute a simulation. Interactive games over the Internet are one of the best examples of multi-site distributed simulation. Interconnecting distributed computers or workstation control panels require WAN, however in server architecture a combination of WAN and LAN is used (Figure 7).

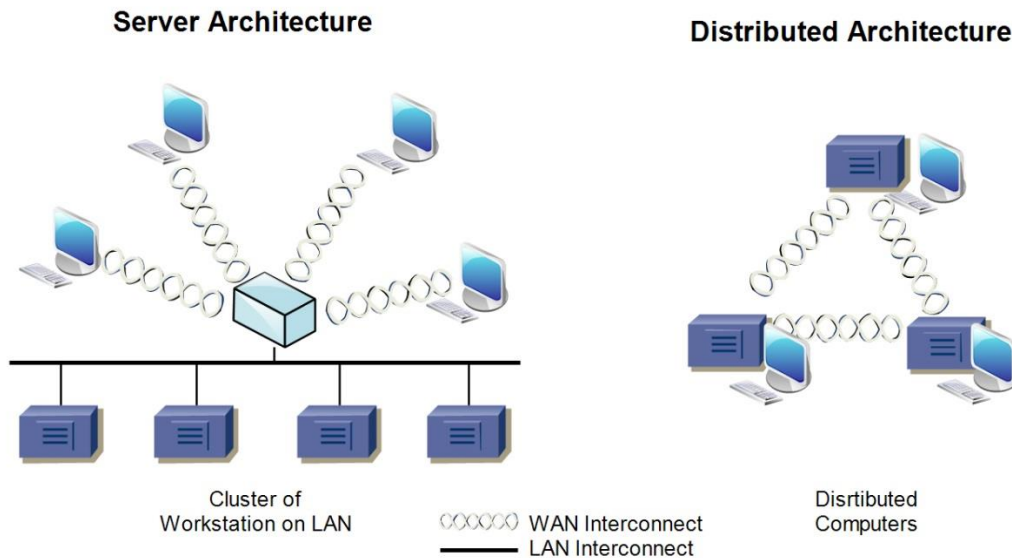

Figure 7 Multi-site distributed simulation

### Time in Simulation

Precise definition for “time” would help to understand different simulation time-based processes. *Physical time* is the time in the physical system, for example from 11:32:26” on October 28, 2015 on 11:50:37” of October 29, 2015. Simulation time is representation of physical time within the simulation; for instance, floating point values in interval [0.0, 24.0]. *Wallclock time* is the time during the execution of the simulation, which is usually the output from a hardware clock (e.g., GPS), for example from 11:20 to 11:30 on October 28, 2015.

Considering the concept of “time” in simulation, there are three different execution modes: *as-fast-as-possible execution*, *real-time execution* and *scaled real-time simulation*. In as-fast-as possible simulations, no fixed relationship necessarily exists between processes in simulation time and advances in wallclock time. In real-time simulation, each advance in simulation time is paced to occur in synchrony with an equivalent progress in wall clock time. And in scaled real-time simulation each progress in simulation time is paced to occur in synchrony with a coefficient times by an equivalent progress in wall clock time (e.g., 3x wall clock time). If the simulator is capable to execute the model in as-fast-as possible mode, execution can be then paced to run in real-time or scaled real-time by introducing delays.

There are two main application domains of parallel and distributed simulations as Parallel Discrete Event Simulation (PDES) and Distributed Virtual Environments (DVEs).

Discrete event simulation refers to the simulations in which the system state changes at discrete time points during the execution. Simulation provides system status snapshots including simulation time stamp (indicating when the physical system event happens in the real world) and state variables. Parallel Discrete Event Simulation (PDES) executes the model as fast as possible using several processors to generate the same results one expects from sequential simulation. It is mainly used in telecommunication networks, computer systems, transportation systems, etc.

Distributed Virtual Environments (DVEs) refer to creating a virtual world, which emulates the realistic model behaviour. The most typical example of DVEs is real time simulations. DVE systems simulate the experience of real-time interaction between multiple users, either at the same place or at distant locations, incorporating computer graphic interfaces, networking, etc.

IN DVEs, Distributed Interactive Simulation (DIS) is a standard network protocol, approved by IEEE, which is mainly used for real time simulation of highly interactive activities like virtual world military emulation platforms. DIS creates an architecture to link concurrent simulations of different components of a system at multiple locations.

### Parallel computation using real time simulators

In real time simulation parallelism, the digital simulator performs parallel computation with multiple input/outputs allowing it to be connected to and control external hardware and equipment directly from the simulation. The processors are also different from those used in offline parallel computing: they are programmed for specific tasks of real time simulation (programmed FPGA in Opal-RT products, or programmed PB5 for RTDS machines) (Figure 8).

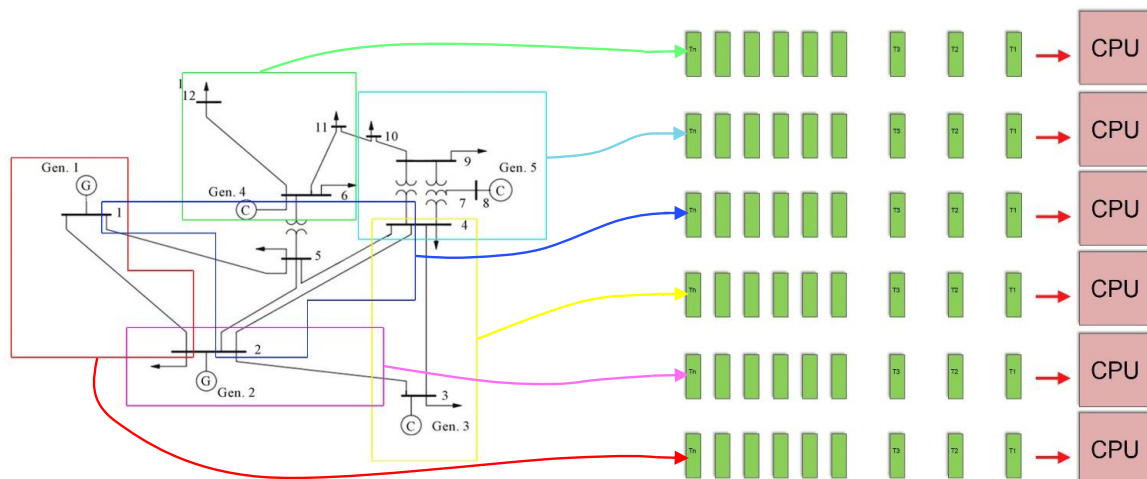

Figure 8 Parallelism in real time simulation

### Advantages and applications to power systems







The main advantage of real time simulation is the possibility of replacing physical devices with virtual devices, which reduces costs, enables more complete and continuous testing of the entire system without interruption. Many possible configurations without physically modification can be tested under possibly dangerous conditions, but safely.

This advantage can be mainly gained from two simulation set up as software in-the-loop and hardware in-the-loop.

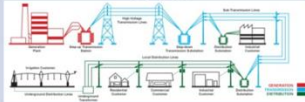
To explain different applications of real time simulation, in a general framework, all possible combinations of “simulated target” and “simulation environment” are represented in Table 1. The

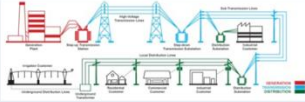
simulated target is the part of the system which is under study and the environment is the part of the system in which the target is analysed and studied (Table 1).

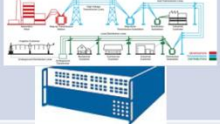
**Table 1 Real time simulation framework**

TARGET	ENVIRONMENT	Type	Abb
<b>REAL</b> 	<b>REAL</b> 	<b>No Simulation</b> (REAL-LIFE)	R-L
<b>SIMULATED</b> 	<b>REAL</b> 	<b>Software In-The-Loop</b> (testing a virtual prototype – before manufacturing or a control strategy)	SIL
<b>REAL</b> 	<b>SIMULATED</b> 	<b>(Power) Hardware In-The-Loop</b> (testing manufactured product or control devices)	(P)HIL
<b>SIMULATED</b> 	<b>SIMULATED</b> 	<b>Pure Simulation</b>	P-S

In software in-the-loop, an algorithm is tested with respect to the real network or system. For instance, a new control strategy for an electrical motor can be modelled and connected to the real motor by means of a real time simulator to validate and test the strategy before deploying the physical controller. Here the objective is to validate the designed system algorithm. When the algorithm passes the required tests and a physical prototype is made, there is still a risk of direct connection of the prototype to the real system. In addition to safety problem, the system or plant may not be available to accommodate the prototype.

Moreover, not all test scenarios are feasible with a real system. In this case, the physical prototype should be validated through a real time simulation of the environment. Therefore a mathematical model of the real environment where the device/system is meant to be used, is created, and the behaviour of the real life would be emulated by a real time simulator which is connected to the under test physical prototype. In this case, any scenario, even faulty behaviour, can be analysed and the integration of device-system would be safely validated.

Considering the advantages of real time simulation, there is a variety of applications to different domains such as electrical systems, mechatronics, robotics and industrial automation. Power system is the focus for this proposed virtually integrated network of laboratories. Looking at commercial solutions, there are two main real time simulation system providers: RTDS and Opal-RT. Both companies' products are mainly used for electricity system simulations and applications: almost all RTDS products and 80% of Opal-RT simulators.

Regarding electrical systems, real time simulation is being widely used in protection and control system development and testing, distributed generation modelling especially renewable energy source (RES) integration, and smart grids development.

For protection system development and testing, closed-loop protection system tests are performed when a real time simulator is combined with a suitable voltage and current amplification system. In control system development and testing, controllers for devices like HVDC, SVC and TCSC are being commonly tested, and generator excitation and stabilization controls are being studied. Regarding real time simulation applications to distributed generations (DGs), the (power) hardware in-the-loop (PHIL) capability of this kind of simulation is extensively utilized as in offline developing multiple DGs in the laboratories connected to distribution networks is relatively costly and time-consuming, while with PHIL, physical devices or grids can be replaced with virtual devices.

### Real time Simulation-Based Decision Support

Figure 9 illustrate an example of a real time simulation-based decision support system for electrical systems in a very general level. Data and models from the real world are fed into a real time simulation by which a variety of tests and studies are performed to finally analyse the benefits gained from new technologies or control strategies. From the results of such analysis, decision makers would implement the new schemes or devices to the real system for design, improvement or reinforcement. As an example, from the virtual model, through fast simulation, a forecasting tool like load forecast algorithms would generate some sort of state transitions (e.g. load profiles for a distribution system representing consumer behaviour) as scenarios to be studied. Then automated or interactive analysis real time tools would simulate system behaviour with respect to the scenarios and system model.

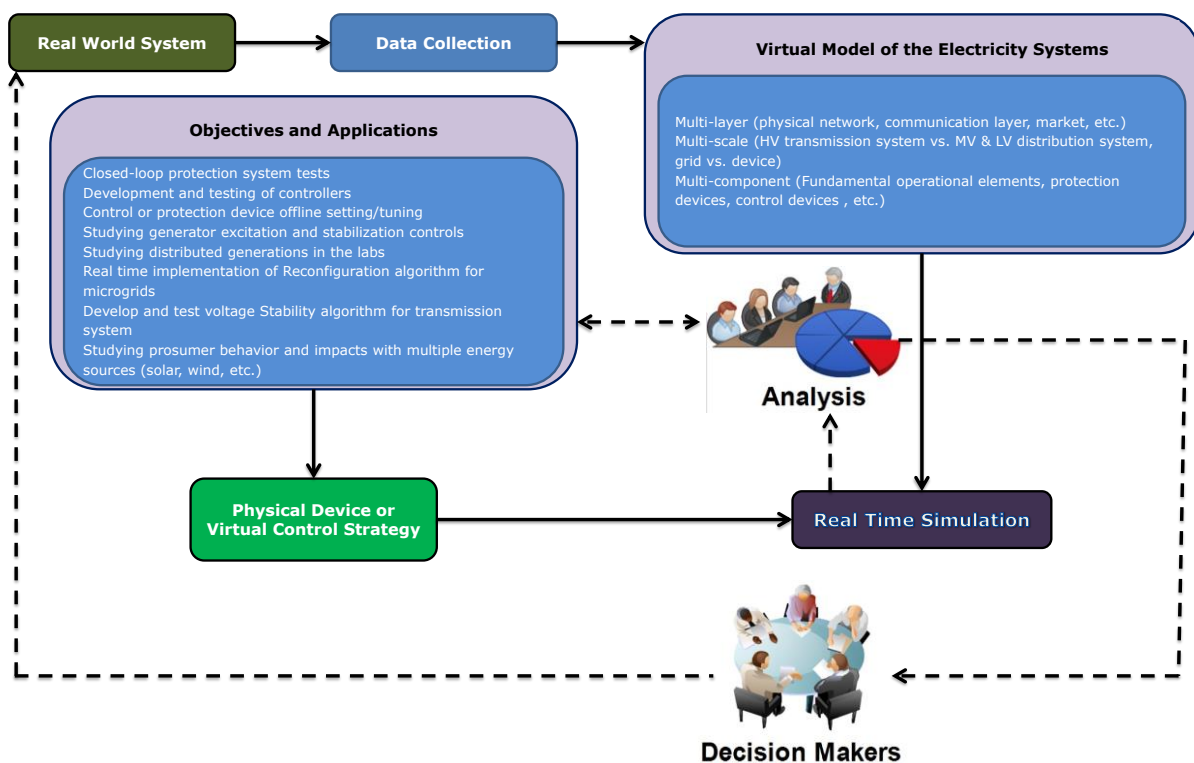

Figure 9 Real time simulation-based decision support

#### 4. European Real Time Integrated Co-Simulation Lab

In recent years, there has been growing interest within the simulation community in the concept of connecting laboratories in real time. Various applications of Internet-distributed simulation, performed by research groups in different areas who share motivation for connecting laboratories were performed [4], [5]. However, with respect to simulation of energy systems and electrical networks in particular, contributions that exist in literature focus on particular cases. This results in a lack of generalized and detailed analyses that are mandatory to formalize the problem and to provide a generic procedure for reliable application of a geographically distributed simulation approach. Such an approach will open new possibilities and will have a vital impact on future capabilities of (Power) Hardware-in-the-Loop (PHIL) [6], [7] testing and large-scale simulation in real time.

Main obstacle to apply the concept of geographically distributed real time simulation in case of a long distance between simulators is impact of a communication medium on fidelity and stability of simulation. The development of an interface that ensures simulation stability and conservation of energy between the two subsystems is not a trivial task. This challenge is well known in the field of PHIL as well as in application of a parallel computation concept for real time digital simulation. The challenge of ensuring simulation stability and conservation of energy between the two subsystems is clearly more significant in case of utilizing Internet as a communication medium for data exchange.

In the area of simulation science the idea is not new. It was originally developed mostly in the military environment with the creation of a co-simulation language called HLA (High Level Architecture) [8], [9]. HLA introduces the concept of Federation to describe the joint execution of simulation across the network. However, HLA was designed to support mostly training activities, so the main task was to support the interaction of different virtual environments to create a realistic scenario for a user.

Similar concepts are also quite typical in the area of gaming, with gaming over the internet becoming a quite established concept.

In creating this new network of laboratories we want to extend the approach further, assuming that the elements interacting with each other are hardware laboratories and not human beings. This brings completely new challenges and in particular the problem of conservation of energy at the interface.

The Institute for Automation of Complex Power Systems at RWTH Aachen has already been performing experiments for geographically distributed real time simulation for large distances under a program supported by the National Research Council of Norway (<https://www.sintef.no/projectweb/proofgrids/>) [10].

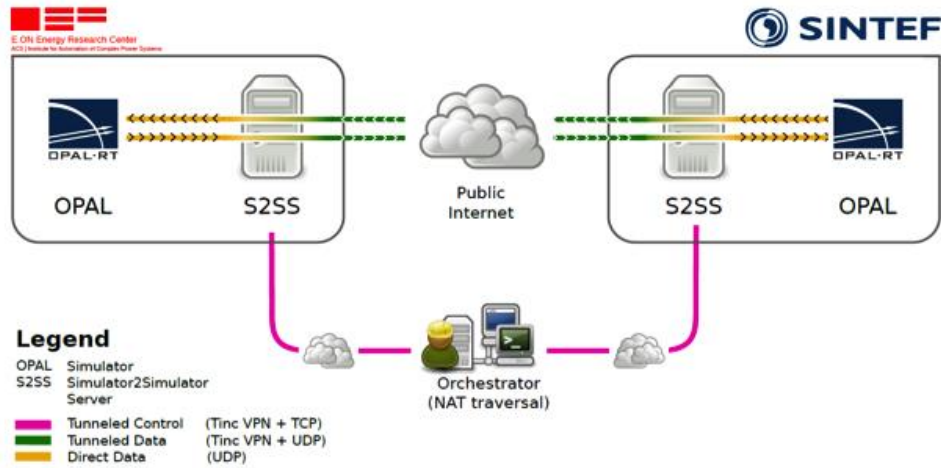

**Figure 10** The architecture of the internet-based distributed solution with SINTEF

In this case, the Laboratories at ACS and SINTEF (Norway) are connected to national research and education networks, DFN and UNINETT, respectively. Further connection between the two laboratories is established via GÉANT and NORDUnet, high-bandwidth networks that interconnect national research and education networks across Europe and Nordic countries.

As illustrated in Figure 10 the simulators are interfaced to the Internet via general purpose Server PCs. These Server PCs are equipped with multi-port Network Interface Cards (NICs), which allow for the separation of the local connection to the simulator from the Internet connection to the remote laboratory. Linux operating system is chosen for the Server PC for its advanced real time features [11] such as high-precision clock. Furthermore, its flexibility allows prioritization and parallelization of communication traffic as well as implementation of additional functionalities, such as dropping of reordered network packets.

User Datagram Protocol (UDP) is selected for data transfer between servers, because in real time applications, dropping packets is preferable to waiting for delayed or re-transmitted lost packets. To provide data security, a Virtual Private Network (VPN) is established. The VPN solution is based on an open source VPN daemon, Tinc [12]. The advantage of Tinc is that it does not require data routing through the central VPN server as usually required by standard VPN solutions.

The described proposed SW solution could be the starting point for the implementation of the future VILLAS system.

The work already performed and the experiment introduced in the following part of this report show the feasibility of the concept. However, there are still many open questions in reaching a generalized and universally accepted solution. This is particularly true if we plan to involve laboratories of many different research fields, different power levels and then with different requirements in terms of time-scale, dynamics and accuracy.

The formalization of the problem in terms of simulation science and computing challenge is particularly significant and may also be adopted in future commercial applications.

Thanks to this set of experiences a set of open scientific questions can be identified:

- How is it possible to compensate in real time the delay created by the communication media?
- How is it possible to keep the simulation engine stable and accurate while running independently in different test sites?
- What is the right content of information that the solvers should share?
- What is the right level of detail that the model executed in conjunction should contain and consequently the most appropriate time step for the interaction?
- Which algorithms should be used for the solvers used at the interface?

### **Distributed real time co-simulation of power systems**

Components of a power system are naturally distributed. Different levels of a power system are also controlled and operated by separate utilities (e.g. transmission system operators, or distribution system operators). The focus of each operating company is on its own system and a little information of the neighbouring connecting nodes or systems. For instance, a distribution system operator of city A does not need to know all the data or topology of the upstream transmission network, and some boundary measurements at the HV/MV substation and some information signal (e.g. dispatching or market signals, etc.) are sufficient.

In order to perform a real time simulation of a large-scale power system, modelling many detailed elements, the real world could be emulated thanks to distributed simulation mechanisms. Distributed real time simulation of interconnected power system is performed by sharing only boundary variables between individual simulation services.

As discussed before, “multi-site” distributed simulation would have even more added value as hardware/software resources are shared and more computational power is provided. There is a common trend toward multi-site distributed simulation in real time. This will open new possibilities and will have a vital impact on future capabilities of power hardware-in-the-loop testing and sharing of high-performance computing infrastructures.

In this case, the whole network should be decoupled in some points and each part should be assigned to a simulator/lab for simulation. From power system point of view, this is the main challenge: how to find the best decoupling points and data to be exchanged among subsystems. There are also a lot of different decoupling methods either under implementation or investigation. A common decoupling method for separating the whole system into subsystems (e.g. at the high voltage side of a HV/MV substation where a distribution system is interconnected to a transmission system) is exchanging current and voltage quantities between the two real-time simulators located in geographic distance. Instead of sending/receiving instantaneous values without any elaborations, the following interfaces can be used:

1. Fundamental frequency phasor: transforming quantities to their time-varying Fourier coefficients for a fundamental frequency phasor (exchanging magnitude and phase values) in one side and send to the other side where an inverse transformation is applied
2. Dynamic phasors with higher components: Fourier coefficients for dynamic phasors with higher order components (harmonics) are captured in one side and sent to the other side for an inverse transformation.

## Benefits

There are mainly four conditions for which the interconnection of multi-site distributed real time simulators can provide a beneficial solution:

1. Soft-sharing of HW/SW facilities within a federation. Utilizing the facilities of other labs if they are not locally available (without the need to move them or go where they are) can be gained as an advantage of multi-site simulation platform. It provides remote testing of devices by integrating (power) hardware in the loop and as well remote software-in-the-loop while the target model is simulated in a different lab.
2. Enhancing simulation capabilities for big systems. If the model is too “large” to be simulated in a single local machine, it needs to be split and co-simulated in more than one machine (lab).

What makes a system “large” is not only the size of the model in terms of node numbers, but also the simulation time step. Simulation time step is usually set based on the purpose of the simulation and the required time scale for the analysis. Regarding the interconnection issue, the time step should set at least equal to the round-trip communication delay. Considering this limit, in case the model cannot be run using all available calculation cores of a local machine, it is a “large” case, which needs to be split and run on more than one machine. However, this limitation would significantly reduce possible applications of real-time multi-site co-simulation concept and different approaches are necessary to exploit all benefits of virtual integration of laboratories across Europe.

3. Soft-sharing of expertise in large knowledge-based virtual environment. Different labs may need real time simulations for different purposes and applications according to their research interests or available experts, while not necessarily in each single lab experts in all fields of power systems are working. In this case, the lab with available HW/SW equipment can enjoy the “knowledge” or “expertise” of another distant located lab remotely in an agreed cooperation. In other words, the equipped lab (e.g. a JRC lab) may not need to host physically visiting experts or researchers for short-term projects/collaborations.
4. Keeping susceptible data/model/algorithm confidential. If in one country some data or system models are confidential and sharing them with other labs require long authorization and administrative procedure, or even not allowed, the model can be simulated locally and exchange appropriate data or simulation results with other interesting labs through real time co-simulation.

## Challenges

Some of the research Challenges and open issues in multi-site distributed real time simulation are listed here:

- How should we develop simulations today, knowing that they may be used tomorrow for entirely different purposes? With respect to sharing models, beside single purpose model implementation, how could be a model built as flexible as possible to be executed for more than one application;
- Multi-resolution modelling (e.g. transmission system vs distribution system, medium voltage vs low voltage power grids, etc.). How should we model a system of systems with different scales?

- Smart and adaptable interfaces (run-time infrastructure<sup>1</sup>, etc.). What interfaces to develop for co-simulation architecture, which is smart, tuneable and flexible?
- Time management. A lot of work completed already, but still a lot of challenges like latency issues should be overcome.
- Implementation architectures: Server vs. distributed architectures. Where and why to implement server or distributed architecture (Figure 7).
- PDES over unreliable transport and nodes. Parallel Discrete Event Simulation (PDES) which executes the model as fast as possible using several processors would face challenges with unreliable transport and nodes.
- High quality and robust systems. In such frameworks, simulation is considered as a service and similar to all services, quality and robustness is crucial.
- Data Distribution Management. What data is relevant and what data is irrelevant, and where to send/receive them.
- Managing large numbers of multicast groups. Utilization of the shared data/model/algorithm through the integrated laboratory should be organized and scheduled considering the large number of distributed users like EU member states size.
- Join/leave times. who to use and when to use?
- Integration and exploitation of network QoS<sup>2</sup>. Error rates, bit rate, transmission delay, etc. should be considered in the network exploiting QoS techniques.

### Networking laboratories

To create the laboratory of the future through interconnecting key capabilities and resources across the EU, a federation of EU real time labs located in different member states of the EU should be made to be conveniently (from both technical and cost-benefit perspectives) used for designing, testing, regulation, analysis technology impact, compliances test in the path toward smart grids for the EU.

Regarding power system analysis, the integrated laboratory facilitates modelling of power grids in greater detail through enabling remote access to software and equipment anywhere in the EU to establish a real-time interconnection to the available facilities and capabilities within the member states. The connection structure follows a server-cloud architecture where the local computers or machines interact with other labs through dedicated VPN (Virtual Private Network) over the GEANT network (the pan-European research and education network that interconnects Europe's National Research and Education Networks). The local VPN servers bridge the local simulation platform at each site and the cloud ensuring the security of the data exchange while offering a better coordination of the communication and the multi-point connection.

The networking activities will make the architecture and data exchange system of the integrated lab. The goal is to manage communication among partners, public relations, quality control, and standardization, to create a multi-site integrated laboratory.

Standard real time simulators (Opal-RT or RTDS) have options to easily separate system model into subsystems in order to be simulated on parallel processors or targets (the simulating machine

---

<sup>1</sup> Run-time infrastructure (RTI) manages interaction between simulations being executed on several distributed computer systems in a general purpose architecture named high-level architecture (HLA).

<sup>2</sup> Quality of Service

consists of several processors). Shared memory and User Datagram Protocol (UDP/IP) or Transmission Control Protocol (TCP/IP) are used to enable distributed parallel computation in a low latency communication environment. Host personal computer or workstation can interact during the real time simulation through these protocols. This provides group collaboration on big projects (models). In this case, each group can model a subsystem and focus on that part of the overall system using its own simulator. Input output data of each subsystem can be communicated to shape the complete model built by each group's contribution. The data can be analysed by individual users (or groups) to study how their subsystem interacts with others', and/or tune parameters live to get optimized expected results.

As standard communication protocols (UDP/IP or TCP/IP) are used by real time simulators, one can connect with simulators from anywhere in the world through internet. Therefore, centralized control, monitoring, remote operation, remote tests and measurements, and/or resource sharing seem feasible and simple. But impact of system splitting on simulation accuracy and stability, and impact of communication medium on simulation stability and fidelity are two main challenges for this internet distributed simulation, which highlights the need to advanced interfaces dealing with issues of delay, jitter and data loss caused by Internet.

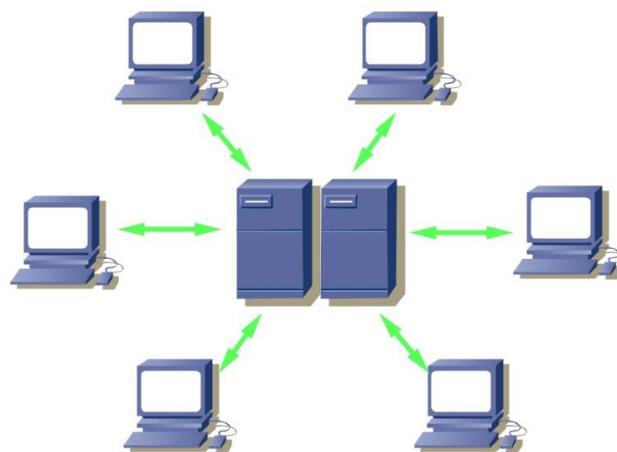

Figure 11 Client/server structure



Figure 12 TCP/IP and UDP/IP Configurations for RTs (Opal or RTDS)

It should be noted that TCP/IP UDP/IP services primarily operate in the client/server structural model. This term refers to a system where a relatively small number of (usually powerful) server

machines is dedicated to provide services to a much larger number of client hosts (Figure 11). In this regard, there are two configurations shown in Figure 12.

For both configurations, it is possible to run more than one client or server on a single simulator. There is no need for additional hardware to be able to use the TCP/IP – UDP/IP functionality of the simulator. A bottleneck may occur if multiple client/servers or messages are exchanged due to the bandwidth or to the routing of the Ethernet port in use. In this case there could be a need for additional Ethernet ports, like EXPI9404PTL Ethernet quad port PCIe card. Simply using already existing TCP/IP is not suitable for real-time data exchange and it requires some C code to be written to create an interface to overcome the time-critical data exchange or communications. Instead, or UDP/IP is more suitable for real-time applications than TCP, however it cannot focus on error detection and correction as efficient as TCP.

As listed in the challenges section, managing the communication in multi-site distributed real time simulation requires developing some software interfaces to do tunnelling using VPNs. It is needed to manage data exchange with the local simulator and Internet communication with another server. The software allows prioritization and parallelization of communication traffic and implements additional functionalities such as dropping of reordered network packets. UDP/IP is recommended to be used for transporting simulation data between two simulators, because waiting for retransmissions of reordered and lost packets is not beneficial for data exchange between real-time simulators (which is the case of TCP/IP).

### **Cloud solution for the interface and architecture**

Figure 13 summarizes the architecture of the proposed infrastructure.

We can identify 4 main parts:

- 1) Laboratories: We expect three types of laboratories:
  - a) A laboratory that is offering only interface to standard commercial real time solutions
  - b) A laboratory that is offering interface to standard commercial real time solutions combined with hardware under test
  - c) A laboratory that is offering interface through a new open source standardized simulation engine. This last case refers to the idea to create a new open source kernel to be shared among partners and to be considered an agreed reference implementation. Locally this solver could also interact with standard commercial solutions when available.
- 2) Historical DB: Experiments can be saved in a central database so that data can be used in future research activities without repeating the experiments. Availability of realistic data is one of the most important points for many research questions in the energy sector
- 3) A cloud interface: the cloud interface will have a multiple use:
  - d) User interface for setting up experiments
  - e) User interface providing a dashboard for visualization
  - f) Exposition of data or simulation services through a standardized Application Program Interface (API) to third parties

As cloud interface, we plan to adopt the platform FIWARE ([www.fiware.org](http://www.fiware.org)) developed within the Future Internet Public Private Partnership of the European Commission.

- 4) RTINT: the RTINT interface is a mix of software and hardware to make the laboratory compatible with the integration of laboratories. This interface will have to be customized depending of the type of infrastructure that needs to be interfaced but it will be based on a common HW/SW architecture.

The cloud component will enable different options and use cases. First of all, it provides a global user interface to the network of laboratories. This interface can be used for setting parameters and conditions in the simulation in a simulation schema or simply be used as monitoring infrastructure to observe the evolution of the experiment.

While the experience will grow over time, the same interface could be used also to implement a concept of Data as a Service offering access to data stored in the data base of experiments to be played for further investigations.

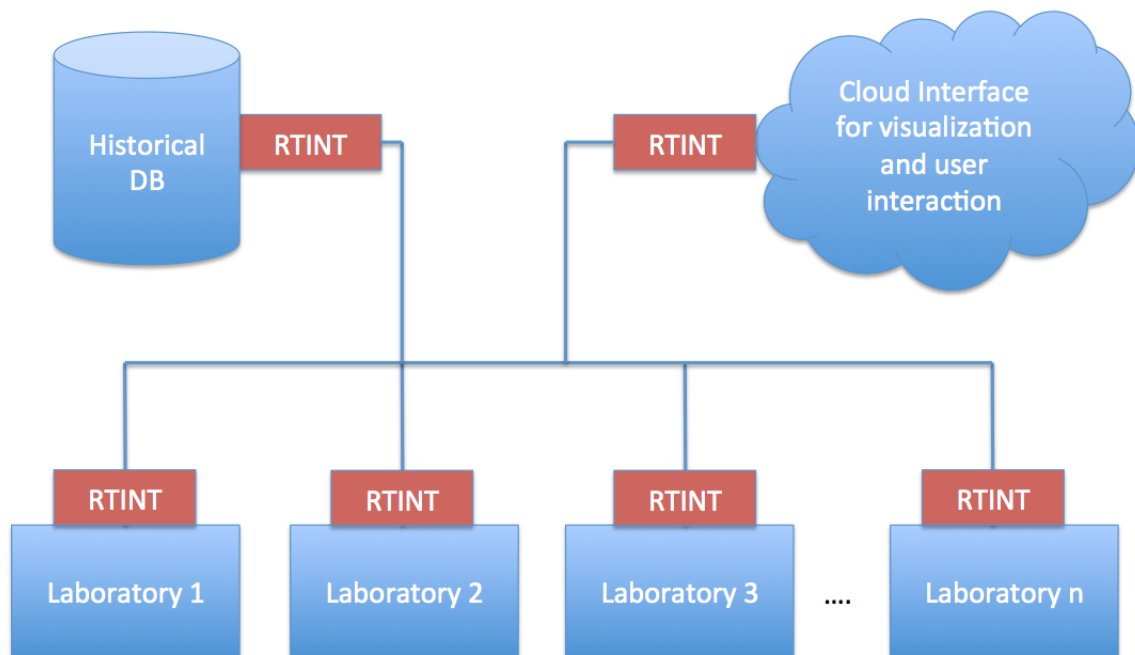

Figure 13 Cloud solution for the interface and architecture

## 5. Demonstration of European 4-site Real Time Integrated Co-Simulation

### Purpose

As demonstration case, 4 laboratories in Germany, Italy and the Netherlands are interconnected to develop a multi-site real time co-simulation platform for power system analysis. This collaboration demonstrated the possibility to practically design and test the realization a federation of EU lab located in different member states of the EU to create the laboratory of the future through interconnecting key capabilities and resources across the EU. It can be conveniently (from both technical and cost-benefit perspectives) used for designing, testing, regulation, analysis technology impact, compliances test in the path toward smart grids for the EU.

Regarding power system analysis, the integrated laboratory facilitates modelling of power grids in greater detail through enabling remote access to software and equipment anywhere in the EU to establish a real-time interconnection to the available facilities and capabilities within the member states.

As a test case, the developed multi-site real-time lab performed a co-simulation of an interconnected transmission and distribution system, where the transmission system (High Voltage, HV) is simulated in a first lab (Aachen, Germany) and the MV (Medium Voltage) distribution grid in a second lab (Turin, Italy). The behaviour of the prosumers on the distribution grid is captured by a dedicated consumer/prosumer behaviour model in a third lab (Petten, Netherlands). In addition a monitoring system, in a fourth lab (Ispra, Italy), analyses the data and simulation results through a cloud system.

On October 29th 2015, in Ispra, at the inauguration of the European Interoperability Centre for Electric Vehicles and Smart Grids, the demo of the real - time integrated co - simulation platform has been presented. The demo sets the path towards the set - up of a federation of EU labs, located in different member states, with at least a node in each EU country, allowing for a cost - effective sharing of HW and SW facilities at EU level in the smart grid sector.

### Co-simulation architecture

The connection structure (Figure 14) follows a server-cloud architecture where the local computers or machines interact with other laboratories through dedicated VPNs (Virtual Private Network) over the GEANT network (the pan-European research and education network that interconnects Europe's National Research and Education Networks). The local VPN servers bridge the local simulation platform at each site and the cloud ensuring the security of the data exchange while offering a better coordination of the communication and the multi-point connection.

The power network model is split into 2 parts as a high voltage transmission grid, and an interconnected medium voltage distribution grid. High voltage grid is modelled and simulated in RTDS (in Aachen, Germany) and the medium voltage network is modelled and simulated in Opal-RT (in Turin, Italy).

A model of prosumer behaviour interconnected to the co-simulation system from JRC (in Petten, the Netherlands) reproduces load/generation profiles. A monitoring system in another JRC lab (in Ispra, Italy) would supervise and monitor the data exchange and simulation performance through a developed cloud system.

Figure 15 represents an overview of the 4 lab interconnections to share resources over the cloud and interfaces for the demonstration of the EU Federation of labs.

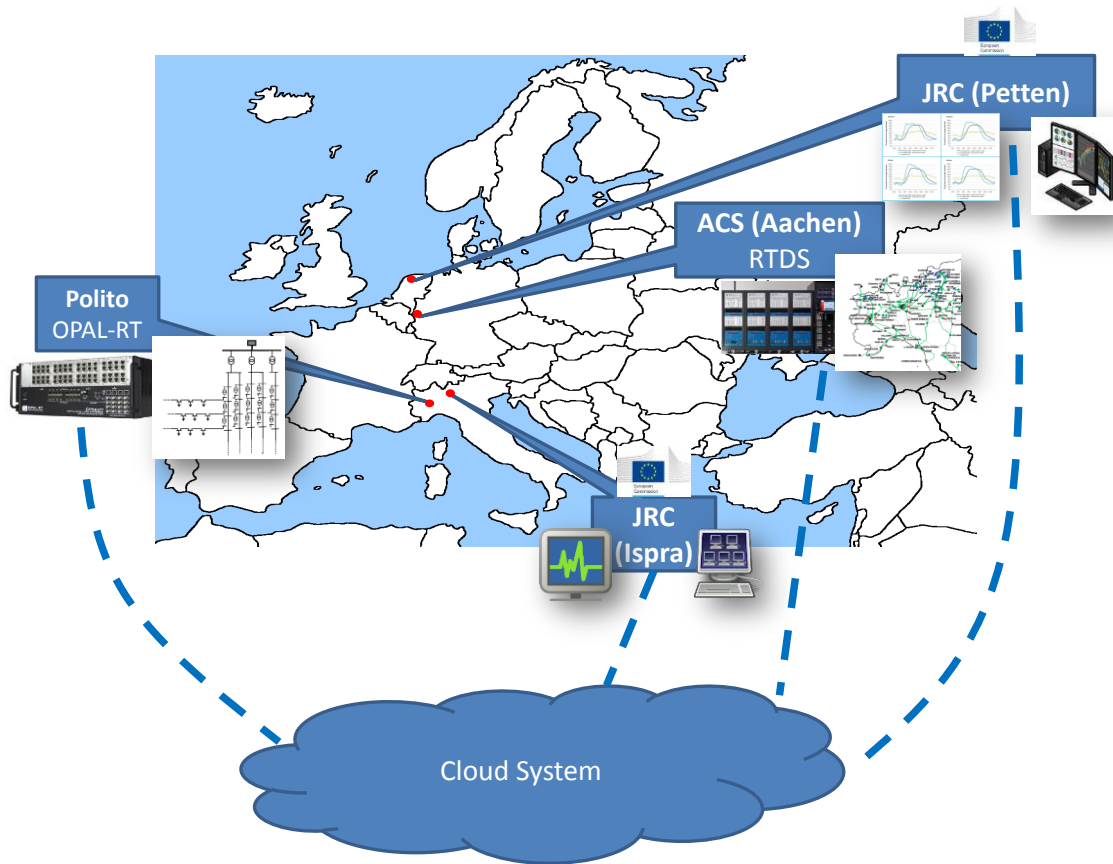

Figure 14 Cloud architecture for the demonstration of the EU Federation of labs

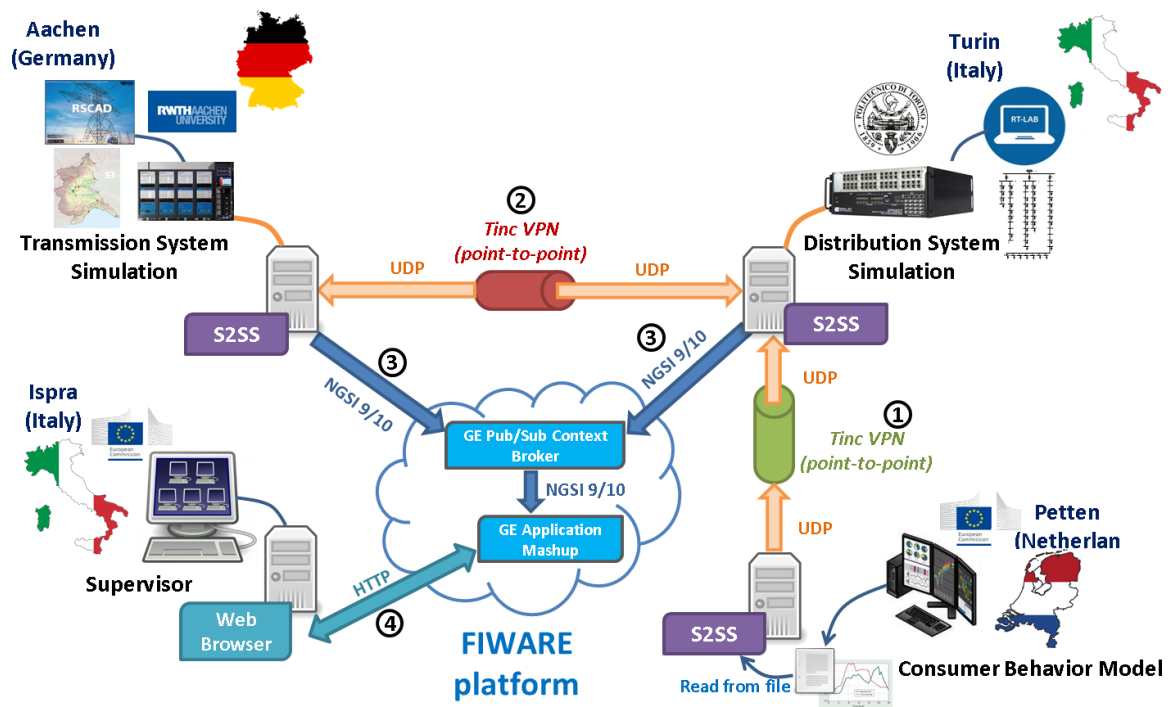

Figure 15 Sharing of resources over the cloud and interfaces for the demonstration of the EU Federation of labs

As described before, the transmission and distribution networks are simulated concurrently in the labs in Aachen and Turin respectively. The connection between the two laboratories (Figure 16) is performed building the structure: RTDS (Aachen) – Server – Internet – Server – Opal target (Polito).

Current and voltage quantities are exchanged between the two real-time simulators located in Aachen and Polito, which simultaneously simulates the transmission and distribution networks respectively. Two different types of interface have already been tested:

- 1) Fundamental frequency phasor: transforming quantities to their time-varying Fourier coefficients for a fundamental frequency phasor (exchanging magnitude and phase values) in one side and send to the other side where an inverse transformation is applied
- 2) Dynamic phasors with higher components: Fourier coefficients for dynamic phasors with higher order components (harmonics) are captured in one side and sent to the other side for an inverse transformation.

Electric current quantity is measured in the distribution network at its HV/MV main bus and transferred to the transmission model through an interface (fundamental frequency phasor or dynamic phasors with higher components) to update an equivalent current controlled source representing the whole distribution system on the HV model. Similarly, the voltage quantity on the HV side is measured and sent to the distribution side to update the values of an equivalent voltage controlled source.

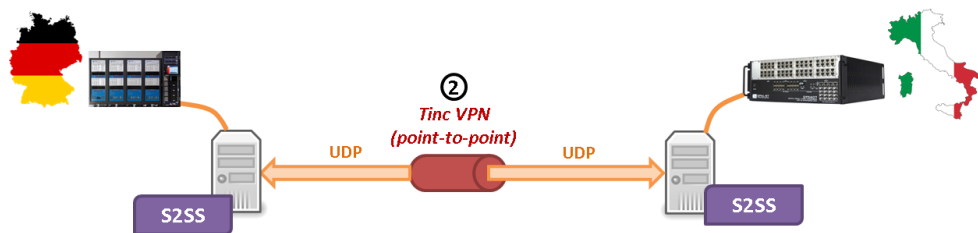

Figure 16 Structure: target RTDS (Aachen) – Server – Internet – Server – Opal target (Polito)

Main components of this structure are Simulator-to-Simulator Server PCs (S2SS), User datagram Protocol (UDP), and Tinc VPN.

Simulator-to-simulator Server PC (S2SS) at each laboratory manages data exchange with local simulator and Internet communication with the remote server. The servers between the simulators and the internet are also for security reasons and for a better coordination of the communication and to have the possibility to make a multi-point connection. By using a server, several targets from the same location can join the network connecting to other remote points. Each server has a 64-bit architecture and at least 2 cores.

The User Datagram Protocol (UDP) is selected to transport simulation data between two simulators. UDP is preferred to its counterpart the Transmission Control Protocol (TCP) because waiting for retransmissions of reordered and lost packets is not beneficial for data exchange between real-time simulators.

Tinc-VPN is used for tunnelling. It uses a public server hosted at RWTH Aachen University for setting up the connection (point to point direct connection) allowing for bypassing firewalls.

Besides VPN network setup, an in-house developed software is used to manage data exchange with the local simulator and Internet communication with another server. It actually aims to manage data exchange between different types of nodes including Real-Time Digital Simulators: RTDS, OPAL-RT, logging and replaying to/from files, and FIWARE interface: GE Context Broker.

The software also performs statistics record of communication links, real-time and low-latency optimization, integrity checks (dropping of reordered packets). It is installed on an open Linux real-time operating system and allows prioritization and parallelization of communication traffic as well as implementation of additional functionalities (such as dropping of reordered network packets).

According to Figure 17, public node (hosted at RWTH) supports to establish direct connections between other firewall'ed nodes. In this structure, VPN to be established for Polito-JRC connection can be separated from VPN established for PoliTo-ACS communication.

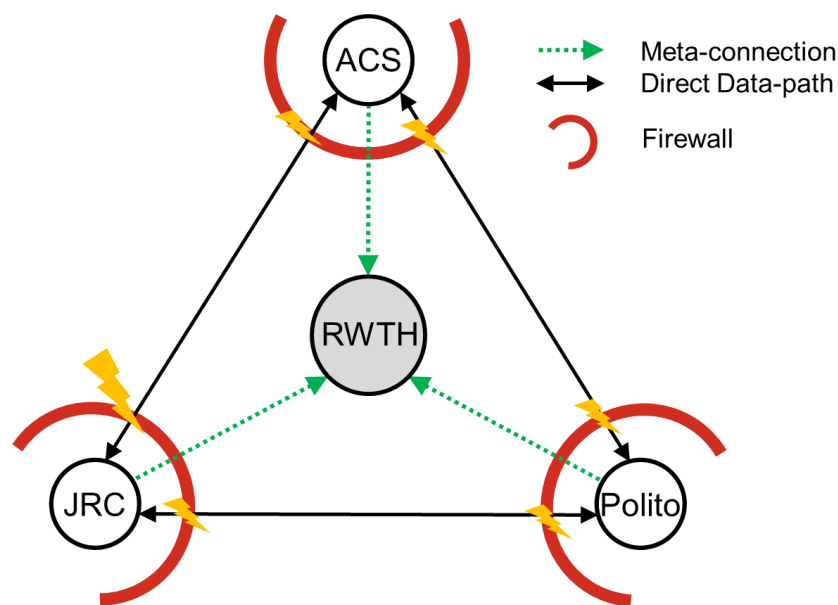

Figure 17 ACS (RWTH-Aachen) – Polito (Politecnico di Torino) data exchange through Tinc VPN

Prosumer behaviour model generates “real-time” active and reactive power quantities consumed (generated) by prosumers and transfers this data through the cloud to update load values of the distribution system. This model is a Matlab-based tool which integrates individual consumer behaviour (considering switches’ status of different appliances/generators of each household and the consumption amount) to create a very realistic aggregated load profile. As references, a set of typical load profiles in Italy are considered for medium voltage loads and aggregated consumption of low voltage feeders. For this remote input-to-simulator data exchange, a simplified read-from-local-file option is adopted here to demonstrate possibility for a remote user to interact and impact simulation scenario. The main components needed for this data exchange are S2SS replaying from local file and sending data to the remote location, User Datagram Protocol (UDP), and Tinc VPN (Figure 18). As noted before, VPN to be established for Polito-JRC connection can be separated from VPN established for PoliTo-ACS data exchange. Option without Tinc VPN is also possible, which is an unidirectional data exchange: only S2SS at JRC in Petten sends data, and PoliTo opens its firewall for incoming traffic from JRC.

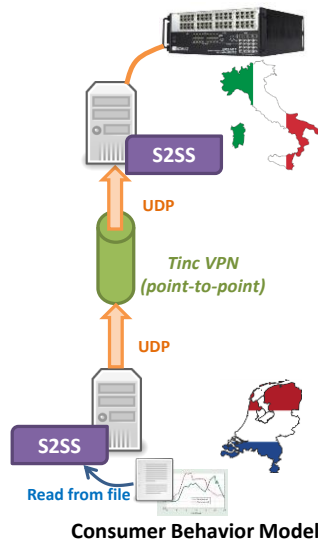

Figure 18 JRC Petten - PoliTo data exchange Input-to-simulator data exchange

As it is shown in Figure 19, the lab in JRC in Petten sends the calculated load profile data to the under-simulation distribution network every 5 minutes (for the demo, every minute).

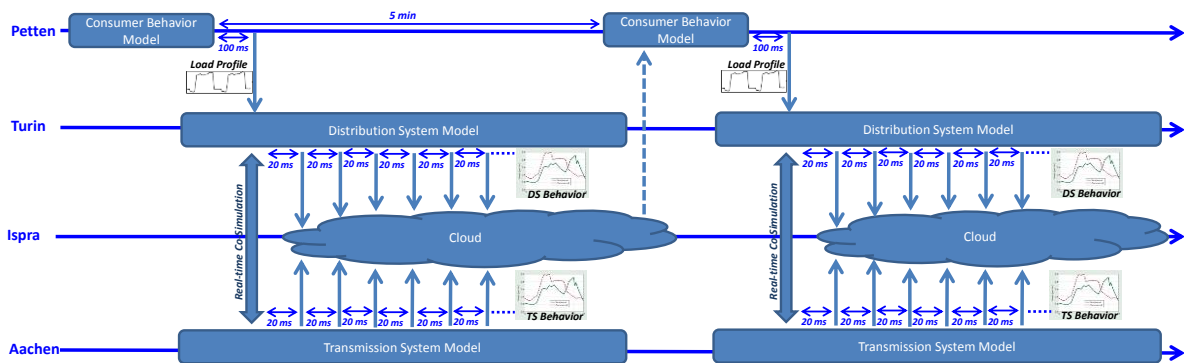

Figure 19 Conceptual scheme of the simulation

Distribution system behaviour in terms of voltage profiles, frequency of overload or quality of supply, as well as transmission system power balance can be observed from the real-time simulation results.

Remote simulation monitoring web-based frontend (Figure 20) is the other part of the whole architecture, which provides flexible remote monitoring of simulation and makes the first step towards Simulation as a Service concept. It creates a safe and powerful virtual environment for validation and evaluation of smart energy applications, and fits future development planned to accommodate user interaction.

Main components are FIWARE-based cloud platform, S2SS, and Web-browser. FIWARE platform is a cloud-based infrastructure driven by the European Union for global deployment of applications for Future Internet. FIWARE delivers a suite of generic enablers where Generic Enabler (GE) is a piece of software that offers a service that is supposed to find application in a variety sectors [13].

S2SS accommodates Simulator-to-FIWARE data exchange. It sends local measurements from simulator to GE Context Broker running on FIWARE platform. Then GE Application Mashup collects data and enables a client-side part running on the user web browser for visualization purposes.

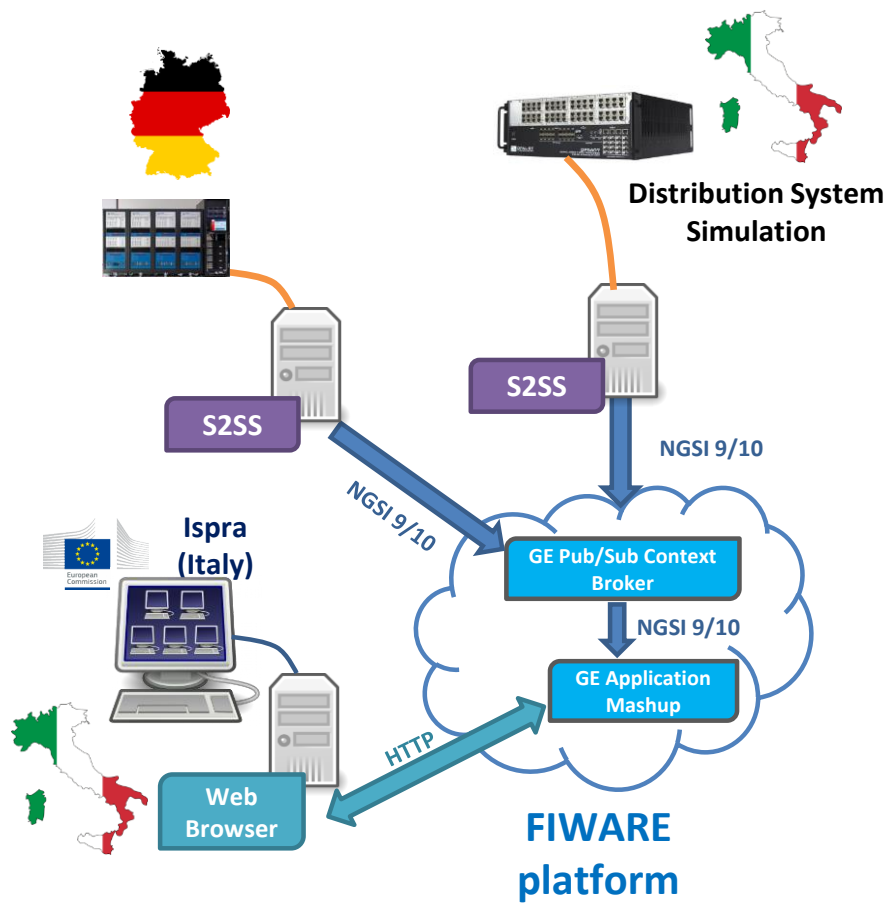

Figure 20 Remote simulation monitoring web-based frontend

## 6. Trial Case: transmission – distribution systems interoperation for different weather and load conditions

Having set up the co-simulation platform, as a study case, we are able to assess how different consumer/prosumer behaviour at the distribution level would affect the network performance of the electricity network represented at both transmission and distribution levels. To translate consumer behaviour to electricity signals, different consumption patterns considering different habits, appliances, environmental and weather conditions, etc. would eventually generate different load profiles in terms of active and reactive power values [P and Q in KW]. We are then able to analyse the consequent impacts on the DS in terms of voltage profile, overloads (frequency of overloads) or quality of supply (sinusoidal shape, harmonics, frequency, etc.). Moreover, we can also assess how consumer/prosumer behaviour, at the distribution level, affects the transmission system. It enables user to evaluate the effects of load shifting in the DS on the power of transmission grid.

### Simulation scenario

The particular objective of the simulated scenario designed for this demo was to demonstrate the need of large-scale power system simulation and to highlight the benefits and the purpose of the detailed simulation models of both transmission and distribution grids. In this scenario, a power system of the future where there is a high penetration of distributed generations is under study. The system is investigated during a summer day around 5 pm, when there is a high demand, people are back from work and a large number of EVs are plugged in for charging. At the same time, local generation from PV panels rapidly drops from a high level to a very low level due to sudden weather change from sunny to cloudy. Consequent voltage drop in distribution system and frequency perturbations in transmission grid are observed performing co-simulation.

### Simulation models

As already discussed, the interconnected transmission and distribution systems are co-simulated on two multi-site distributed simulators under influence of an external model located in a third different place modelling consumer behaviour. We use a coherent exemplificative realistic case that is based on a portion of the Italian transmission system (Piedmont Region) and a portion of the distribution system in the town of Torino.

The whole transmission layer consists of 86 buses, 110 lines, 20 generators, and 54 equivalent loads for the MV substations (Figure 22). This HV grid interconnects with the MV network (modelled in the other lab) through one of its HV/MV substations (STURA) where the data exchange takes place between the two real-time simulators (Figure 21).

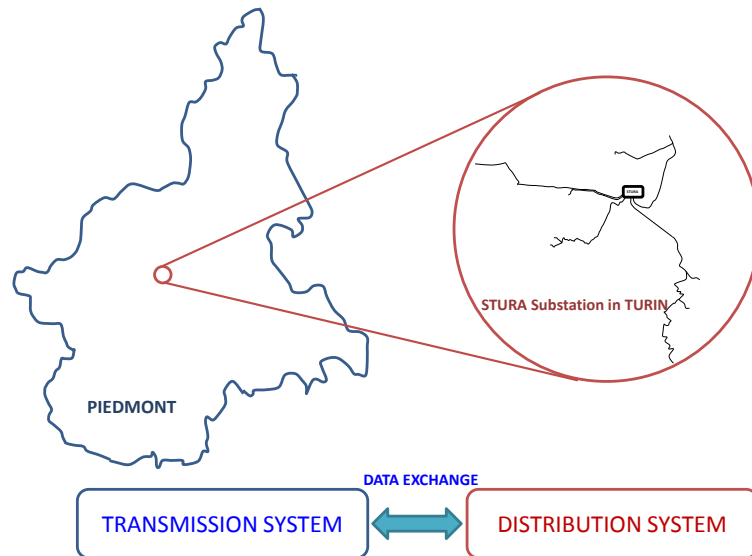

Figure 21 Schematic representation of transmission-distribution systems co-simulation

### Transmission network model

As described in previous sections, a portion of the Italian transmission system (Piedmont Region) is simulated at ACS-RWTH (Aachen) laboratory on a Real-Time Digital Simulator (RTDS) (Figure 22). RTDS is a special-purpose simulator developed for performing electromagnetic transient simulations in real time. The RTDS system at ACS laboratory consists of eight racks with 4 processor cards (Giga Processor Card - GPC) installed in each rack. RTDS utilizes parallel processing techniques to fulfil high computational demands coming from the simulation of power systems with a typical time step of  $50\mu\text{s}$ .

A summary of the HV transmission system to be simulated on RTDS is provided in Table 2. A single rack of RTDS can be used for the simulation of a power system with up to 66 nodes (22 buses). Therefore, for the simulation of the transmission system adopted for this study, at least 4 racks of RTDS must be utilized. For solving network solution each rack dedicates one GPC card. Approximately 50% of computational load of the remaining 12 GPC cards are utilized for simulation of 20 generators, 86 lines and 54 loads. The rest of computational power is at disposal for other components such as control units. Therefore, if the system is distributed properly, computational power of 4 RTDS racks fulfils computational requirements for the system under study.

Table 2 Transmission Network Summary

Number of 380 kV buses	26
Number of 220 kV buses	60
Number of generators	20
Number of lines	86
Number of loads	54
Maximum total active capacity [MW]	8458
Maximum total reactive capacity [Mvar]	4338

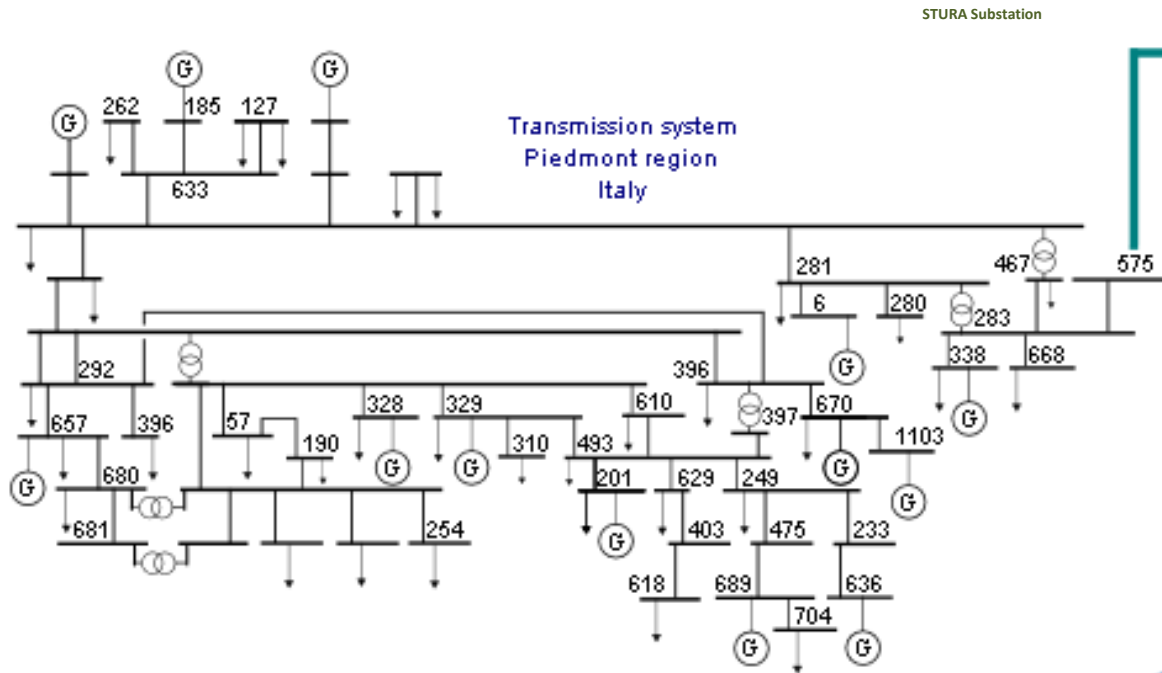

Figure 22 Modelled transmission system topology

### ***Distribution network model***

The portion of the MV network (Figure 23) consists of a primary substation with three MV-22 kV busbars, each of which is fed by a transformer characterized by voltage ratio of 220/22 kV. Two transformers are characterized by a nominal power of 63 MVA and the other one by a nominal power of 55 MVA. There are 5 MV lines starting from the HV/MV substation. A summary of the network specification is provided in Table 3. The real-time platform RT-LAB developed by OPAL-RT are used for simulating the distribution system. 12 cores operating at 3.46 GHz are available on the Polito target computer which runs with the operating system RedHat. DS Model has been developed in MatLab Simulink and SimPowerSystem (SPS) environment. To execute the model on the real-time simulator, a fixed step time (initially 50 microseconds) is selected. The ARTEMIS software from OPAL-RT has been used to provide fixed-step solver dedicated to complex power systems.

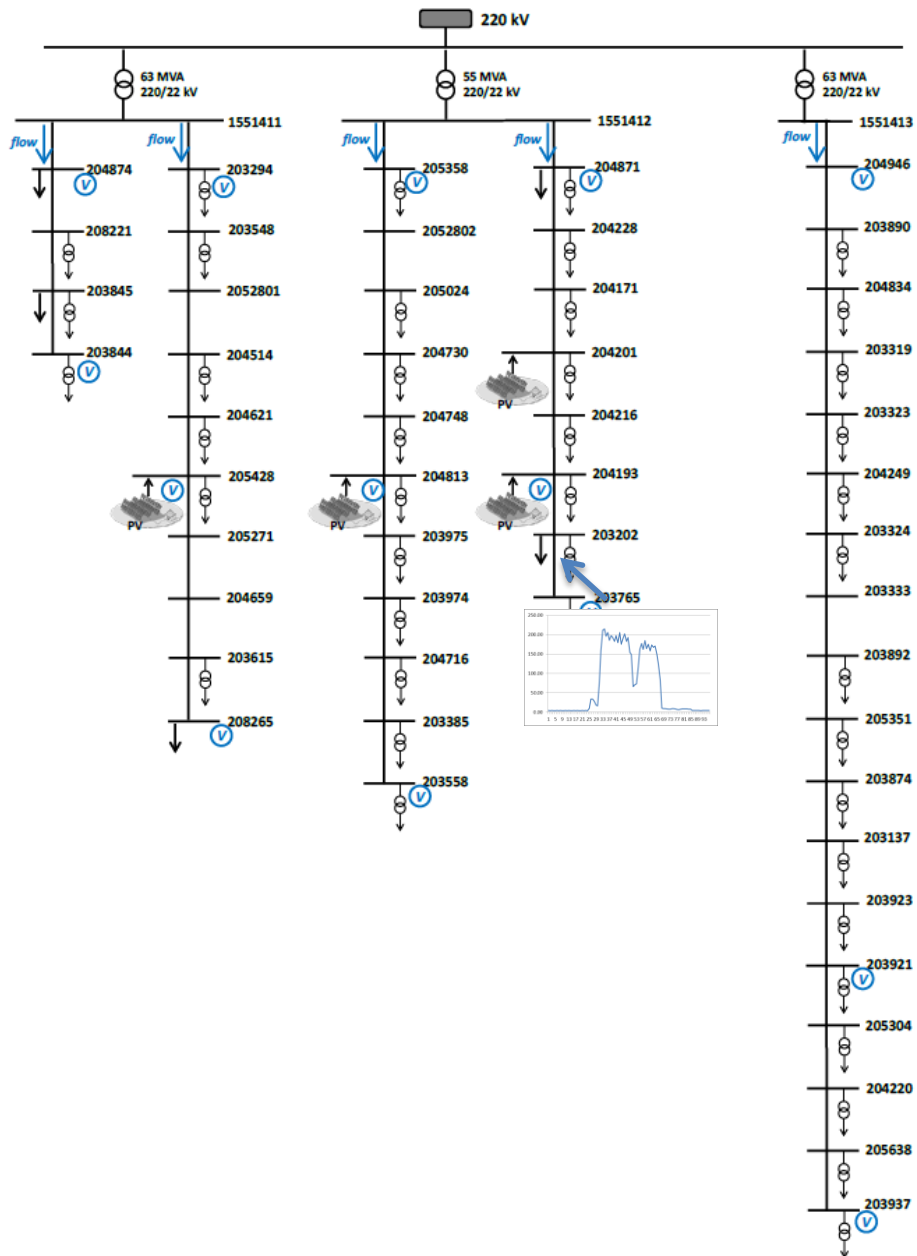
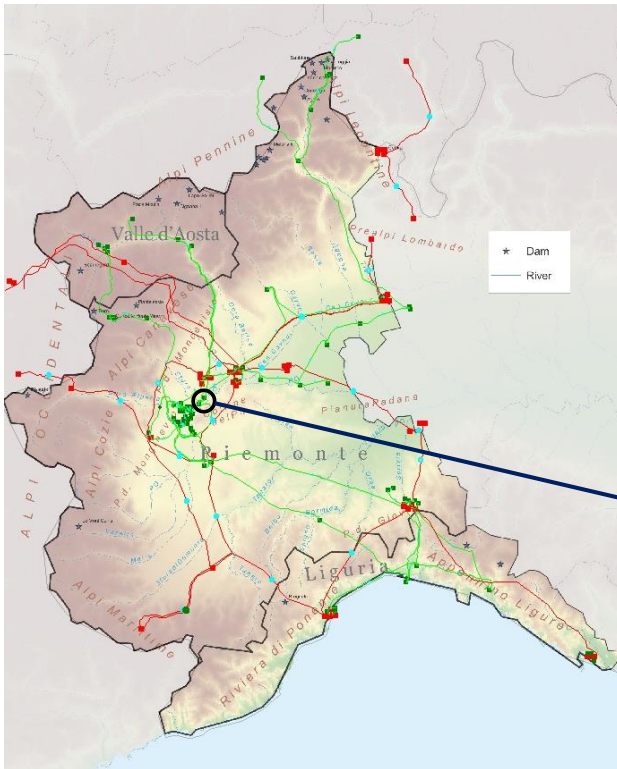

Figure 23 Modelled distribution system topology

Table 3 Distribution Network Summary

<b>HV/MV transformers</b>	3 (220/22 kV, 2x63 MVA + 1x 55 MVA)
<b>Number of MV feeders</b>	5
<b>Number of MV buses</b>	49
<b>Number of lines</b>	49
<b>Total length of lines [km]</b>	38.54
<b>Number of MV/LV transformers</b>	40
<b>Number of LV customers</b>	742 mono phase and 8293 three phase
<b>Total contractual load [MW]</b>	37.056
<b>Number of equivalent LV models</b>	40
<b>Number of MV customers</b>	6

### TRANSMISSION SYSTEM 380 – 220 KV PIEDMONT REGION - ITALY



Number of 380 kV buses	26
Number of 220 kV buses	60
Number of generators	20
Number of lines	110
Number of loads	54
Maximum total active capacity [MW]	10291
Maximum total reactive capacity [Mvar]	4338

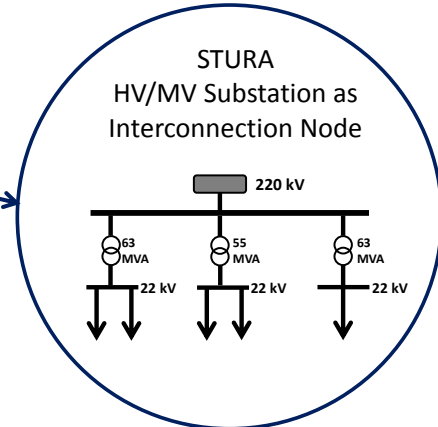

### DISTRIBUTION SYSTEM 22 KV – A PORTION OF TURIN CITY - ITALY

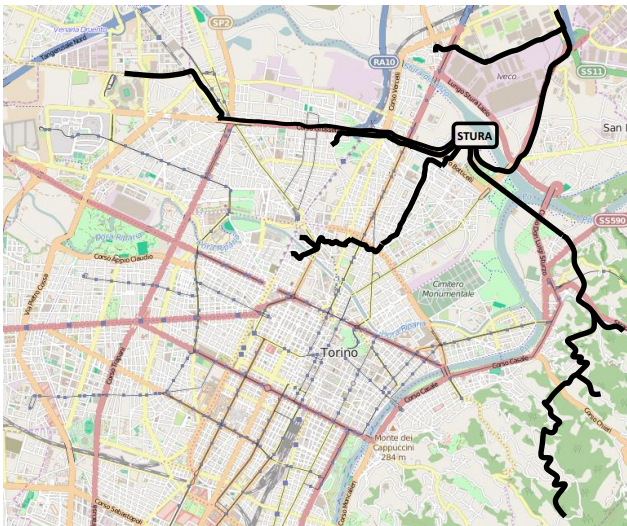

Number of MV buses	49
Number of lines	49
Total length of lines [km]	38.54
Number of MV/LV transformers	40
Number of LV customers	742 mono phase, 8293 three phase
Total contractual load [MW]	37.056
Number of equivalent LV models	40
Number of MV customers	6

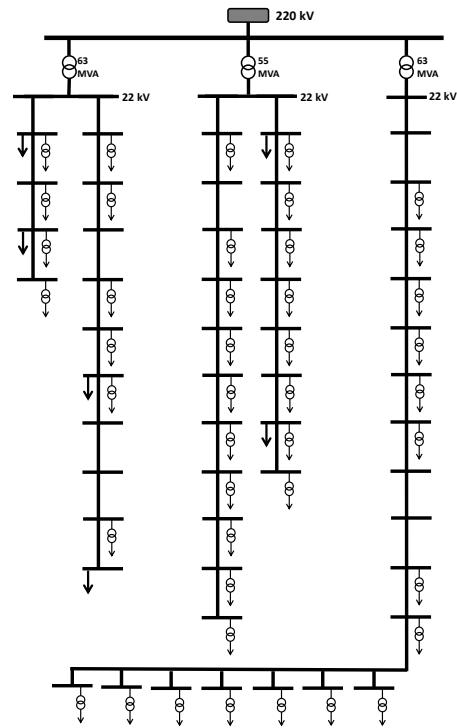

Figure 24 Transmission and Distribution network models of the Simulation Scenario

## Simulation results

For the demonstration, two large screens were devoted: one to demonstrate a graphical representation of the co-simulation (Figure 25), and one to show live streaming of the 4 laboratories (Figure 26). The latter screen shows RWTH university lab in Aachen (Germany) on top left, Politecnico di Torino laboratory in Turin (Italy), The former screen was also used as a graphical interface enabling user to trigger the scenario and obtain consequent results visualized on some maps or charts. There was also a button on the touch screen to switch between 2 layouts, one as a high conceptual layout (Figure 25), and the other one as a technical layout (Figure 27) to provide more details for the users or visitors with more power system expertise or interest. In this technical graphical interface, user can select any of the measurements listed next for any of the grids (transmission and distribution systems), in order to see the corresponding results as dynamic curves on the charts.

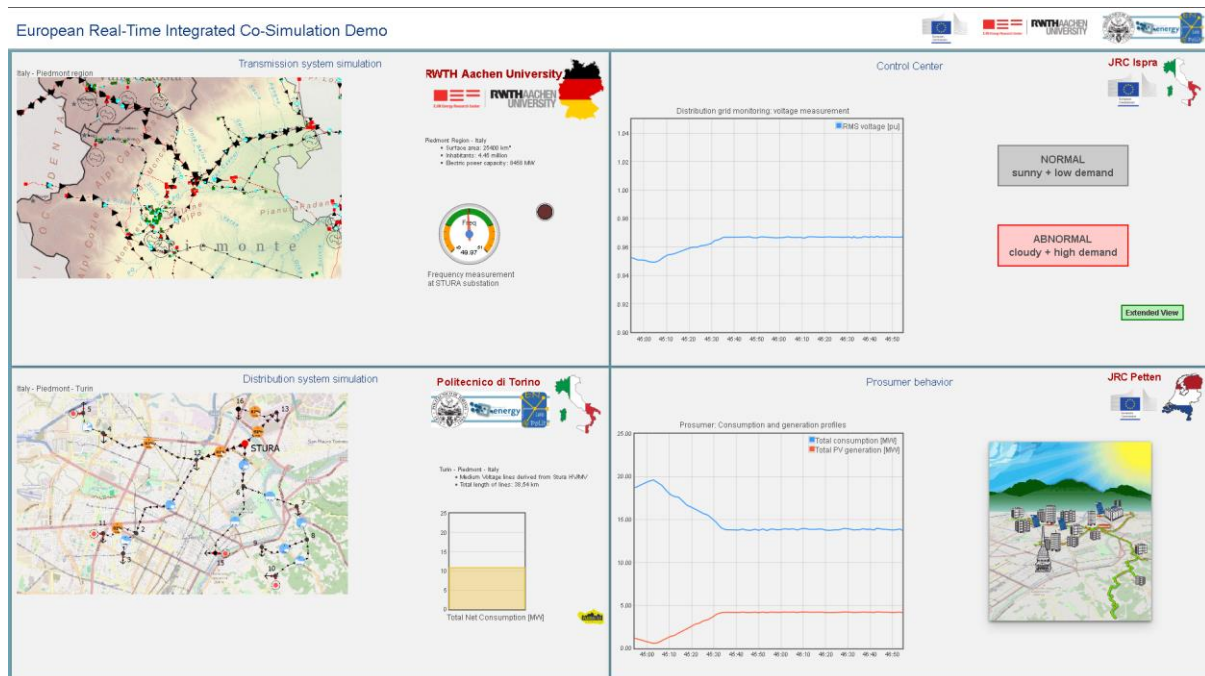

Figure 25 Demonstration final graphical interface - Conceptual layout



Figure 26 Live streaming of the 4 integrated labs for the demonstration

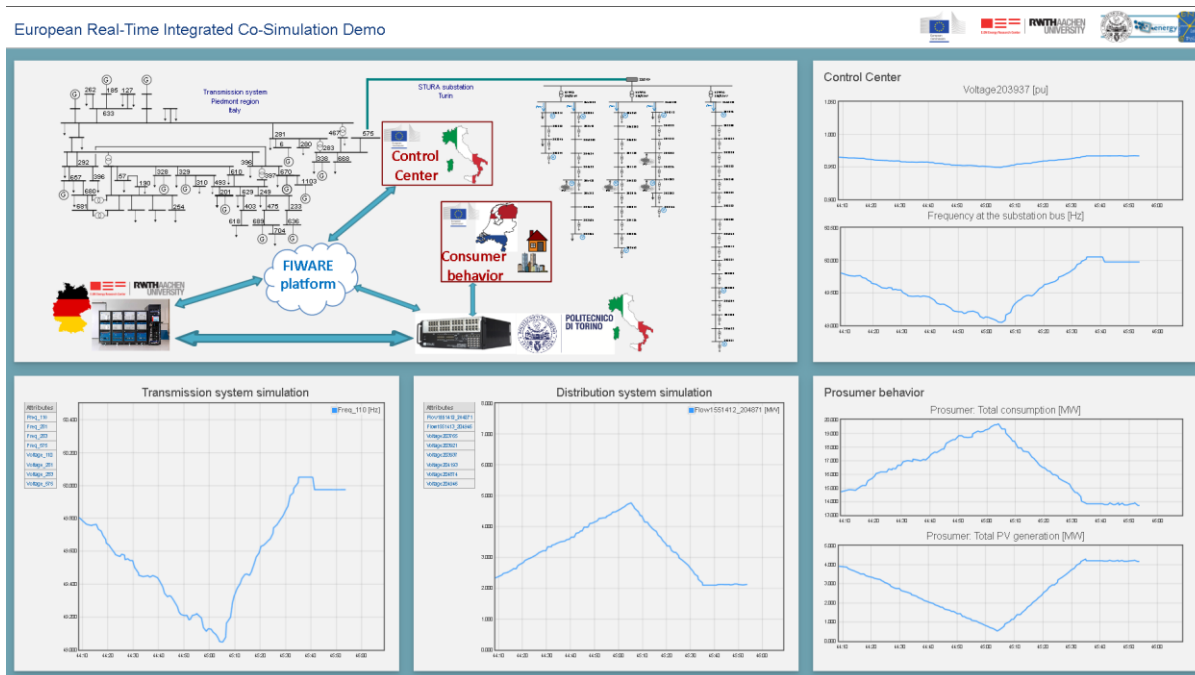

Figure 27 Demonstration final graphical interface - Technical layout

As introduced before, in this work, we assessed transmission and distribution system operation under extreme consumer/prosumer behaviour at the distribution level. The integration of variable renewable energy is challenging in three different time scales: less than a few seconds, stability of the system faces challenges, from some minutes to some days, system demand-supply may lose balance, and in long term (some months or even years), the adequacy of the power system becomes

more important to meet system peak demand. For the demonstration, we analysed a scenario with balancing challenges from variable renewable energies – PV generators in this grid. In the study case, there are 4 PV generators which supply a portion of the local consumption.

The PV generation is assumed to drop (e.g. a big cloud appears suddenly and change solar irradiance due its intrinsic variability and uncertainty characteristic) at the same time when the residential consumers are increasing their consumption plugging EVs and utilizing more appliances, as illustrated in Figure 28 and Figure 29. It results in a sudden increase in power absorption from the substation connected to the transmission system.

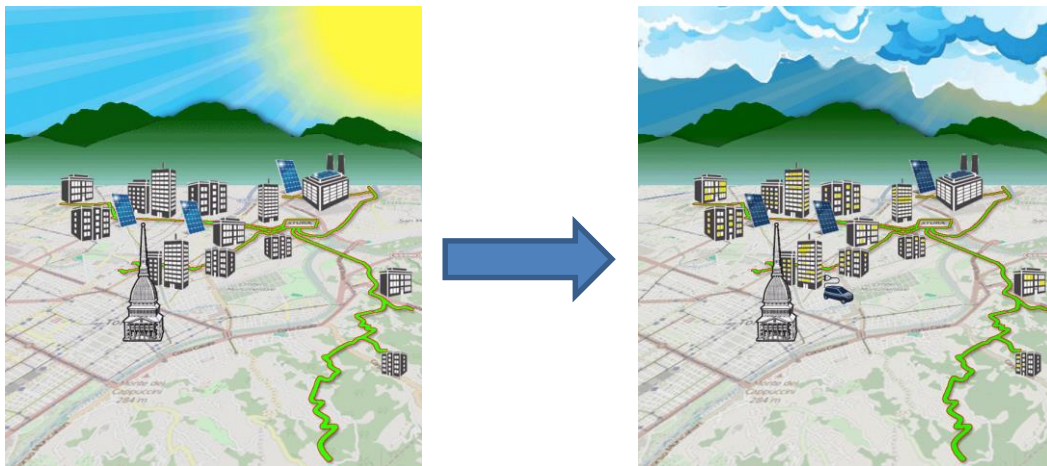

Figure 28 The demo scenario: PV generation drop and simultaneous demand increase

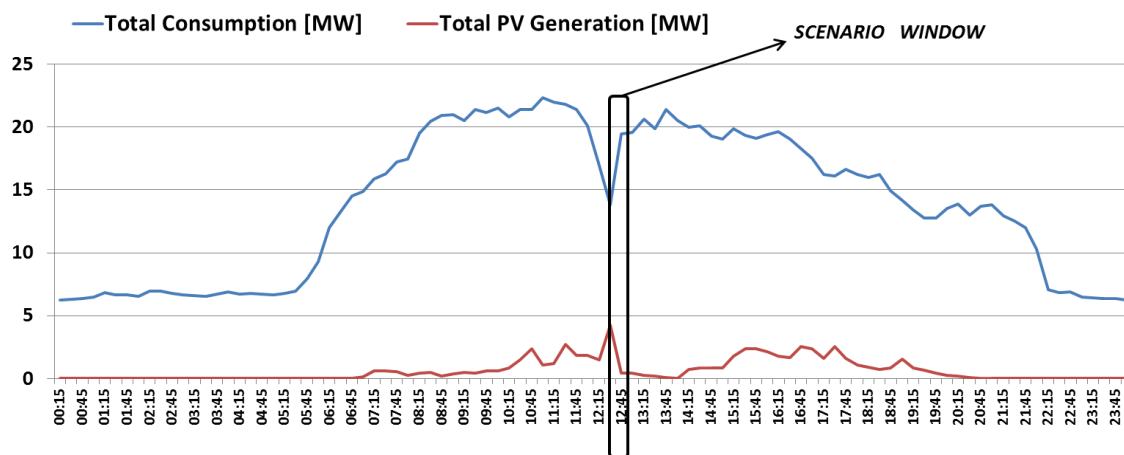

Figure 29 Indication of scenario window in 24-hour total load/generation profiles

Web application based monitoring provides visualization of online simulation data achieved from both distribution and transmission systems, from Opal simulator in Politecnico di Torino (Italy) and RTDS simulator located in ACS lab at RWTH Aachen university (Germany) respectively. This visualized interface is useful not only for third parties, but it extends simulation monitoring available at individual laboratories that is limited to the local system (i.e. transmission or distribution system).

From the technical visualised layout, two measurements are selected to show in Figure 30 and Figure 31. The corresponding bus numbers could be found on the topology graphs of the distribution and transmission systems depicted in Figure 23 and Figure 22, respectively. Figure 30 indicates voltage drop at the end of the longest MV feeder in the distribution system caused by the described event. Web application provides a customized set of selections of different measurements for monitoring, like flow of lines, voltage at some buses.

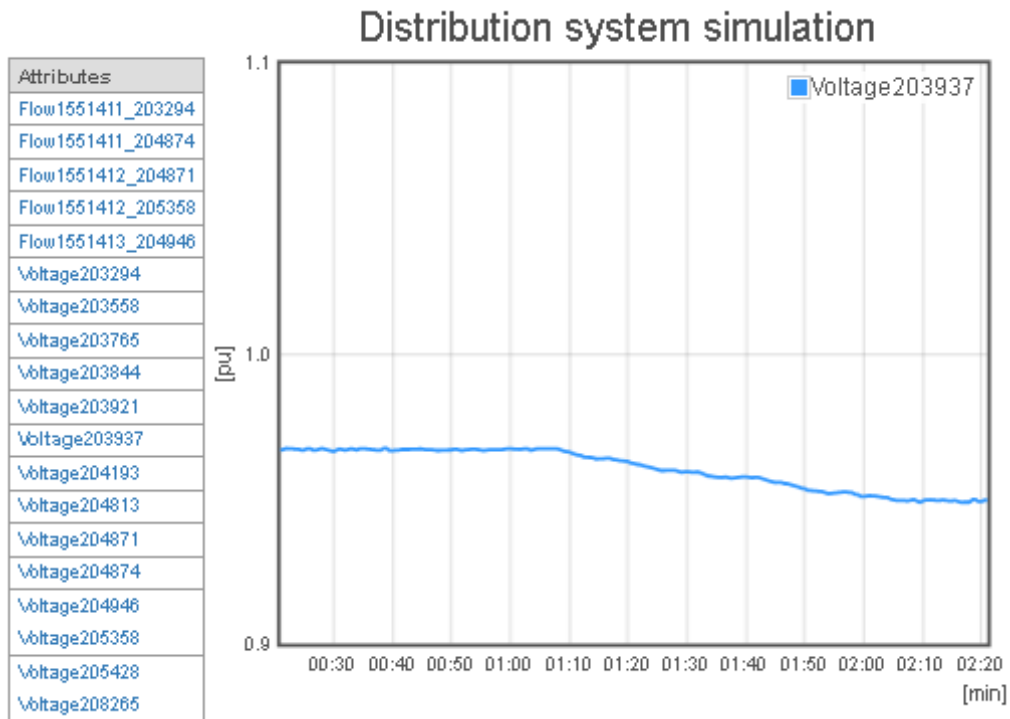

Figure 30 Monitoring of distribution system – RMS voltage at the end of the feeder

One measurement selected from transmission system is shown in Figure 31. It refers to frequency measurement at one of the neighbouring buses to the substation where distribution system is connected. Although the rotating inertia of the large conventional generators mitigates fluctuations in the studied scenario, high penetration of PV generators could eventually have a significant impact on the transmission grid.

## Transmission system simulation

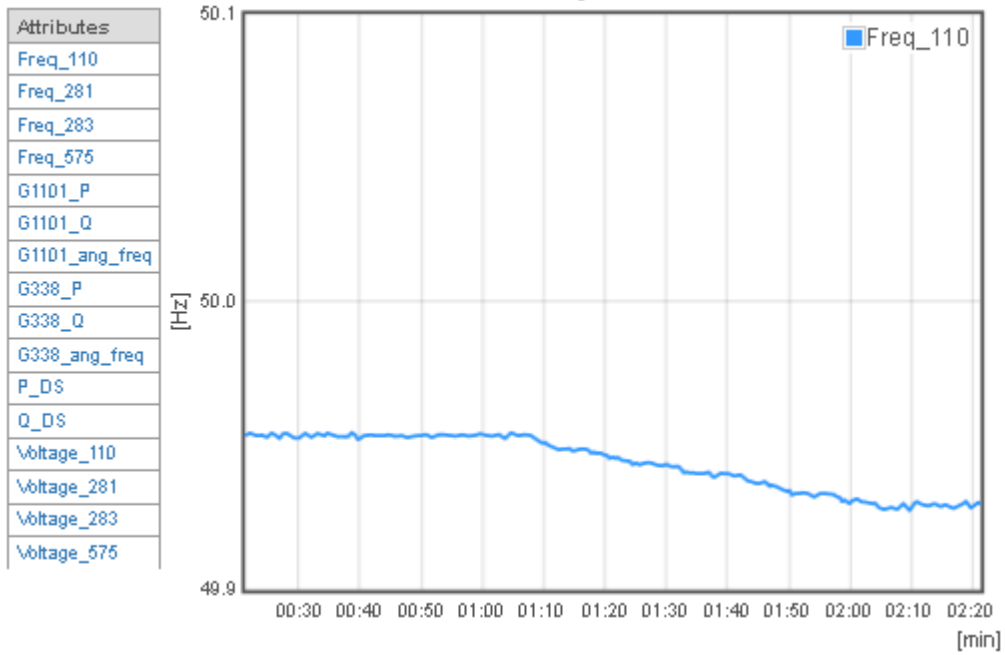

Figure 31 Monitoring of transmission system – frequency measurement

## 7. Concluding remarks and steps ahead

The transition towards smarter electricity systems requires new and advanced European and national policies. A highly qualified input to the decision-makers is needed and must be based on solid scientific knowledge of the emerging systems, technologies and services. Therefore, a scientific research platform pooling excellence from different European member states and institutes is needed.

A particularly interesting tool, in the case of power systems, to share HW and SW research capabilities located in different laboratories in different locations is real time simulation, thanks to some specific features:

- the possibility of replacing physical devices with virtual devices (software in-the-loop and hardware in-the-loop);
- the possibility of performing multi-site distributed simulations, interconnecting the simulators like the real devices or systems would be interconnected in the real environment.

For the above mentioned reasons, it will be advantageous to create in a federation of real time labs located in different member states of the EU, interconnecting key capabilities and resources.

A demonstration case has been developed and presented, and is described in this document. Four laboratories in Germany, Italy and the Netherlands were interconnected to develop a multi-site real time co-simulation platform for power systems analysis. The demonstration case was working on a pure simulation basis, without hardware or software in the loop.

Steps ahead in the development of a European platform for distributed real time modelling & simulation of emerging electricity systems will be:

- the extension of the laboratories network to new nodes;
- the optimization and standardization of the data communication between the different nodes;
- the testing of the platform on complex systems, with hardware in the loop simulations;
- Developing smart and adaptable interfaces (run-time infrastructure<sup>3</sup>, etc.)
- Regulation framework on Time management (Join/leave times) and Data Distribution Management
- Regulation for property right and cost allocation
- Etc...

---

<sup>3</sup> Run-time infrastructure (RTI) manages interaction between simulations being executed on several distributed computer systems in a general purpose architecture named high-level architecture (HLA).

## References

- [1] European commission, Progress towards completing the Internal Energy Market (COM 2014-634 final).
- [2] European commission, Energy union package: a framework strategy for a resilient energy union with a forward-looking climate change policy (COM 2015-80 final)
- [3] European commission, Delivering a new deal for energy consumers (COM 2015-339 final)
- [4] T. Ersal, M. J. Brudnak, A. Salvi, Y. Kim, J. B. Siegel and J. L. Stein, "An iterative learning control approach to improving fidelity in internet-distributed hardware-in-the-loop simulation, " *Journal of Dynamic Systems Measurement and Control* 136(6), pp. 061012-061012-8, 2014
- [5] J. L. Bastos, J. Wu, N. Schulz, R. Liu, and A. Monti, "Distributed simulation using the Virtual Test Bed and its real-time extension," in *Proceedings of the Summer Computer Simulation Conference (SCSC '07)*, pp. 757–765, July 2007
- [6] Lentijo, S.; D'Arco, S.; Monti, A., "Comparing the Dynamic Performances of Power Hardware-in-the-Loop Interfaces," *Industrial Electronics, IEEE Transactions on* , vol.57, no.4, pp.1195,1207, 2010
- [7] Wei Ren; Steurer, M.; Baldwin, T.L., "Improve the Stability and the Accuracy of Power Hardware-in-the-Loop Simulation by Selecting Appropriate Interface Algorithms," *Industry Applications, IEEE Transactions on* , vol.44, no.4, pp.1286,1294, July-aug. 2008
- [8] Li Meng; Liu Buquan; Zuo Xiaoliang, "Study for Parallel Scheduling of HLA-Based Simulation Objects," *Computational Intelligence and Design (ISCID), 2013 Sixth International Symposium on* , vol.2, no., pp.129,132, 28-29 Oct. 2013
- [9] Peng Ding; Xiao Song; Wen Shi; Feng Zhou; Shaoyun Zhang, "A two-stage load balancing method for HLA simulation system on cloud simulation platform," *Guidance, Navigation and Control Conference (CGNCC), 2014 IEEE Chinese* , vol., no., pp.2192,2197, 8-10 Aug. 2014
- [10] M. Stevic, S. Vogel, S. D'Arco and A. Monti, "Feasibility of geographically distributed real-time simulation of HVDC system interconnected via AC networks", *IEEE PowerTech*, June 2014, Eindhoven (NL)
- [11] Linux RT-patch: <https://rt.wiki.kernel.org/>
- [12] Tinc VPN project: <http://tinc-vpn.org>
- [13] <http://www.fi-ware.org>

## List of figures

Figure 1 Representation of European scientific framework.....	8
Figure 2 sequential computing .....	11
Figure 3 Parallel Computing.....	12
Figure 4 Parallel Simulation (M: Machine, P: Processor).....	12
Figure 5 Distributed simulation .....	13
Figure 6 Replicated trials.....	13
Figure 7 Multi-site distributed simulation .....	14
Figure 8 Parallelism in real time simulation.....	15
Figure 9 Real time simulation-based decision support.....	17
Figure 10 The architecture of the internet-based distributed solution with SINTEF.....	19
Figure 11 Client/server structure.....	23
Figure 12 TCP/IP and UDP/IP Configurations for RTs (Opal or RTDS) .....	23
Figure 13 Cloud solution for the interface and architecture .....	25
Figure 14 Cloud architecture for the demonstration of the EU Federation of labs .....	27
Figure 15 Sharing of resources over the cloud and interfaces for the demonstration of the EU Federation of labs .....	27
Figure 16 Structure: target RTDS (Aachen) – Server – Internet – Server – Opal target (Polito).....	28
Figure 17 ACS (RWTH-Aachen) – Polito (Politecnico di Torino) data exchange through Tinc VPN .....	29
Figure 18 JRC Petten - PoliTo data exchange Input-to-simulator data exchange.....	30
Figure 19 Conceptual scheme of the simulation .....	30
Figure 20 Remote simulation monitoring web-based frontend .....	31
Figure 21 Schematic representation of transmission-distribution systems co-simulation .....	33
Figure 22 Modelled transmission system topology .....	34
Figure 23 Modelled distribution system topology.....	35
Figure 24 Transmission and Distribution network models of the Simulation Scenario .....	36
Figure 25 Demonstration final graphical interface - Conceptual layout.....	37
Figure 26 Live streaming of the 4 integrated labs for the demonstration .....	38
Figure 27 Demonstration final graphical interface - Technical layout.....	38
Figure 28 The demo scenario: PV generation drop and simultaneous demand increase .....	39
Figure 29 Indication of scenario window in 24-hour total load/generation profiles .....	39
Figure 30 Monitoring of distribution system – RMS voltage at the end of the feeder .....	40
Figure 31 Monitoring of transmission system – frequency measurement .....	41

## List of tables

Table 1 Real time simulation framework.....	16
Table 2 Transmission Network Summary .....	33
Table 3 Distribution Network Summary .....	35

Europe Direct is a service to help you find answers to your questions about the European Union

Free phone number (\*): 00 800 6 7 8 9 10 11

(\*): Certain mobile telephone operators do not allow access to 00 800 numbers or these calls may be billed.

A great deal of additional information on the European Union is available on the Internet.

It can be accessed through the Europa server <http://europa.eu>

Our publications are available from EU Bookshop (<http://bookshop.europa.eu>),  
where you can place an order with the sales agent of your choice.

The Publications Office has a worldwide network of sales agents.

You can obtain their contact details by sending a fax to (352) 29 29-42758.

## JRC Mission

As the Commission's in-house science service, the Joint Research Centre's mission is to provide EU policies with independent, evidence-based scientific and technical support throughout the whole policy cycle.

Working in close cooperation with policy Directorates-General, the JRC addresses key societal challenges while stimulating innovation through developing new methods, tools and standards, and sharing its know-how with the Member States, the scientific community and international partners.

*Serving society  
Stimulating innovation  
Supporting legislation*

