

Structural calculations by horizontal and vertical interoperability for the redevelopment of existing buildings

*Original*

Structural calculations by horizontal and vertical interoperability for the redevelopment of existing buildings / Chiaia, B., Davardoust, S., Osello, A.. - CD-ROM. - (2015), pp. 650-658. (Fabbrica della conoscenza. Le Vie dei Mercanti Aversa-Capri 11-13 June 2015).

*Availability:*

This version is available at: 11583/2615898 since: 2015-08-08T17:31:34Z

*Publisher:*

La Scuola di Pitagora

*Published*

DOI:

*Terms of use:*

This article is made available under terms and conditions as specified in the corresponding bibliographic description in the repository

*Publisher copyright*

(Article begins on next page)

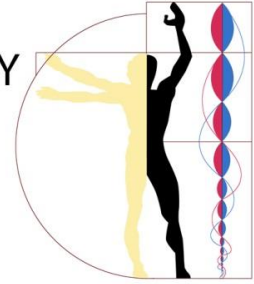

## Structural calculations by horizontal and vertical interoperability for the redevelopment of existing buildings

**Chiaia Bernardino, Sanaz Davardoust, Anna Osello**

DISEG, Polytechnic of Turin, Turin, Italy

bernardino.chiaia@polito.it

sanaz.davardoust@polito.it

anna.osello@polito.it

### Abstract

By considering the importance of Italy which is cradle of civilization and has a rich architectural and cultural heritage, unfortunately, current attention of community is not paid as much as should be; at the same time the Italian real estate challenges contemporary designers in the field of heritage buildings care more than in the new constructions. Moreover, increasing awareness of problems related to seismic safety is also an important issue, especially as a result of dramatic seismic events of recent years.

The aim of this research is the integration of Structural analysis into Building Information Modeling (BIM) quickly using a methodology by which get data flows and information exchanges, with no data losses, between architectural software (as Revit Architecture and Archicad) and structural analysis software (as Axis VM) both static and seismic calculation.

For the process of exchanging data from Revit to other software was considered as an "intelligent interoperability" with good results passing through Industry Foundation Classes (IFC) format, analyzing problems and possible solutions by using Solibri Model Checker.

In this way, investigation of the possibilities of maintenance and structural stability analysis, in support to the comprehension of the behavior of elements within the whole building organism will be easier in achieving the connection between BIM and structural analysis for existing/historical buildings. The paper also elaborates risks and barriers to BIM implementation and future trends.

**Keywords:** BIM, intelligent interoperability, cultural heritage, seismic safety

### 1. Introduction

Seismic safety issues needs to be integrated in the existing building defining thus the preventive conservation a real necessity in everyday practice. A way to make this operation easier is to provide a unique design base on which both architectural and structural experts can share their analysis and modification proposals. Providing a shared design base is one of the BIM aims.

BIM has received much attention in recent years due to its ability to develop a new methodology for the design, construction and facility management based on the exchange of information. To implement the integrated design process with the issues of seismic safety is necessary to allow the exchange of information between the tools of each technical specialist involved in the design process. Specifically, it is essential to define a methodology to automatically switch the data flow between BIM software and structural calculation tools. This is designed in order to allow an iterative verification of the significance of the changes to the whole life cycle project aimed at pursuing a process of structural analysis through the database using the .ifc format.

The purpose of this study is to examine and describe the horizontal interoperability (between two architectural BIM software) and vertical (between architectural and structural software) and the opportunities offered by BIM process applied at existing buildings at Primo Liceo Artistico di Torino.

## 2. Methodology

This study focused on the use of BIM oriented software applied to existing asset with a deepening of the horizontal interoperability between Revit and Archicad (parametric software) and vertical interoperability with Axis VM (structural software). It was used the .ifc format and verified within Solibri Model Checker, with particular attention architectural and structural data. The research covered the following topics:

- 2.1 To use .ifc file which exports the model from Revit and imports it into ArchiCAD; subsequently exports it from ArchiCAD and imports it into Axis VM (horizontal-vertical interoperability);
- 2.2 To use .ifc file which exports the data from Revit and imports them into Axis VM (vertical interoperability);
- 2.3 To implement Static and seismic analysis and the verification of structural elements with possible modification of the geometry in Axis VM;
- 2.4 Exporting modified geometry from Axis VM and imports it into Revit (vertical interoperability);
- 2.5 Exporting modified geometry from Axis VM and imports it into Archicad; subsequently exports it from ArchiCAD and import it into Revit (vertical-horizontal interoperability).

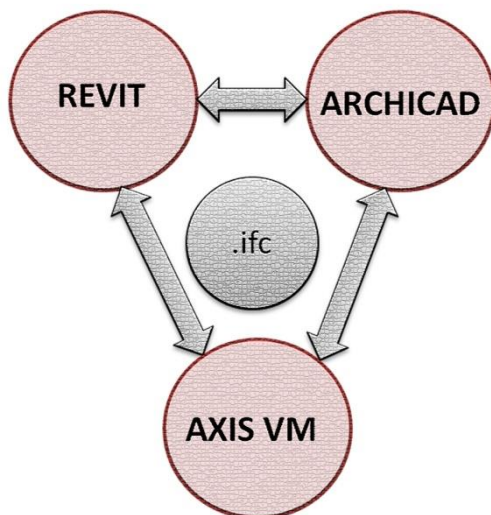

**Fig. 1:** Horizontal interoperability between Revit and Archicad (parametric software) and vertical interoperability with Axis VM (structural software)

### 2.1 To use .ifc file which exports the model from Revit and imports it into ArchiCAD, subsequently exports it from ArchiCAD and imports it into Axis VM

The first phase normally coincides with the consultation and the retrieval of archival material and contemporary photographic and metric survey both as a whole and in detail that characterize the structure and the architecture of the building.



**Fig. 2:** Photographic and metric survey

The structure was composed of precast elements such as columns and beams. The floor was made with TT beams, the plinths and the connecting beams were cast in situ. Having available all these informations were possible to start the design phase of the parametric model, inserting all the required data for structural calculations and to process some hypotheses earthquake safety. For the modeling of the proposed study was used parametric software Autodesk Revit 2013. Particular attention was paid to the definition of each element, starting from the standard families available in the software library, subsequently were customized to make the model to matches the existing building. First was created a structural grid, on which were placed the plinths, columns and beams. The structure itself was very regular although sometimes were found the differences between elements: for example, some columns were the presence of brackets of the beams while in others the section was reduced to allow a support plan.

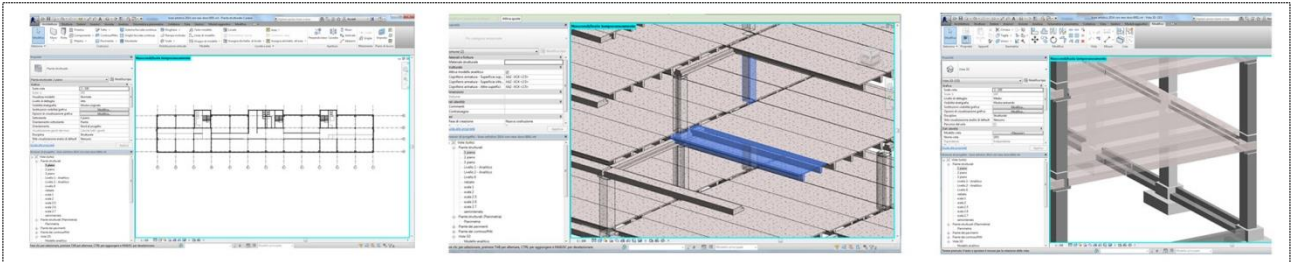

Fig. 3: Precast elements (columns, beams and floor was made with TT beams)

Once completed the model, the analysis focused on the exportation from Revit to ArchiCAD, occurring before the benefits of horizontal interoperability and then intelligent vertical through the "filtering" which was a selection of data to export, carried out by hiding unnecessary elements between ArchiCAD and Axis VM. In this case study the first step (horizontal interoperability) was revealed a loss of data for complex elements - later it will be possible to see the example of columns. This phase was particularly useful to identify ways of modeling more efficient that able to increase interoperability both horizontal and vertical.

## 2.2 To use .ifc file which exports the data from Revit and imports them into Axis VM

The transmission of the data between Revit 2013 and Axis VM was carried out using IFC exchange format, the only currently recognized internationally by the IAI (International Alliance of Interoperability). To optimize the export processes was possible to act on specific categories, filtering all the architectural elements to isolate the structural ones. So, under the same category, such as beam, there were different elements, it can be filtered the instance and selected only a specific type of item. So, it was possible to enter the menu and select *export* options. In this section there are 660 categories with related entities, a code that identifies the category. If this code is absent, it can be obtained from the website buildingsmart.it and ensure that the entities are supported by Autodesk.

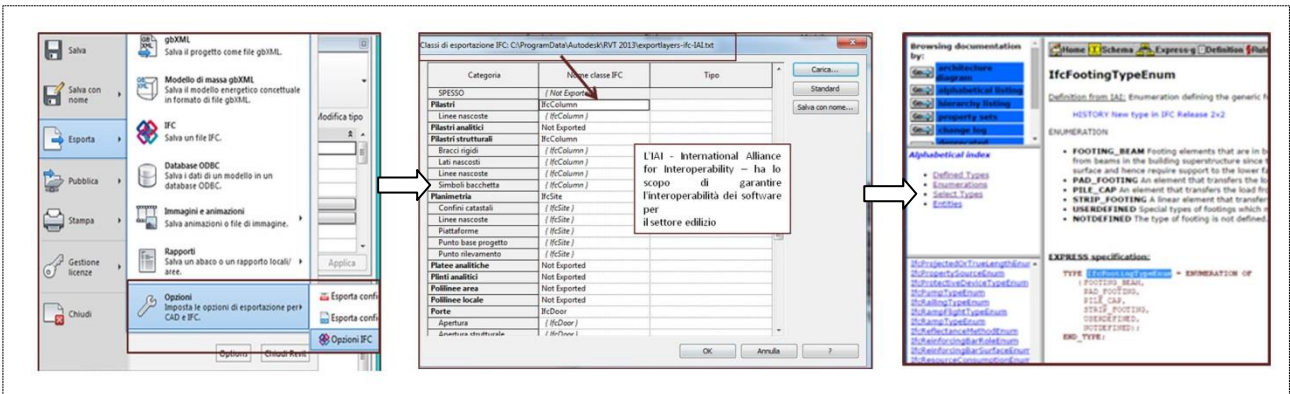
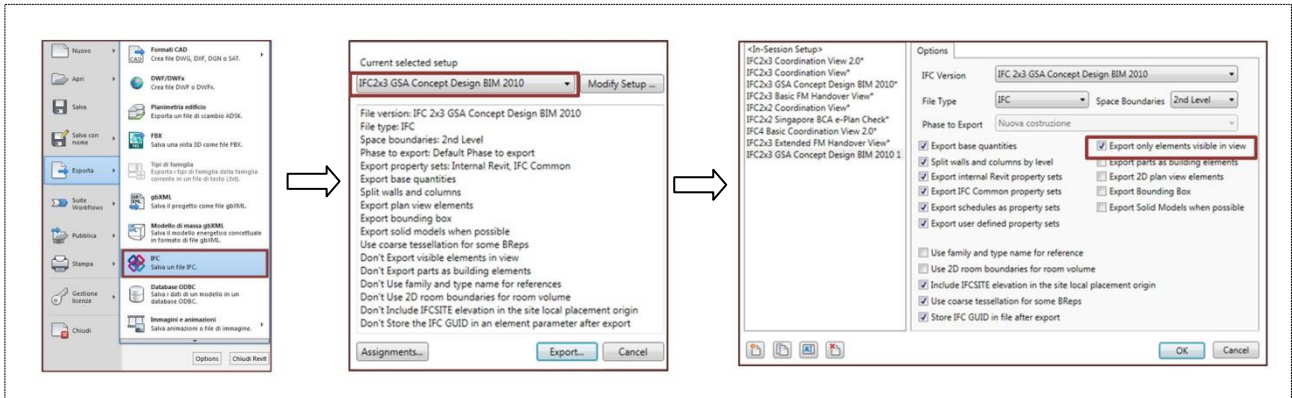

Fig. 4: Using IFC exchange format (Industry Foundation Classes)

Exporting the file in the traditional way, all the data of the model, including the hidden categories, can be transmitted to other software. In this case, it was necessary to isolate some specific data (like structural

element); moreover, it is possible to install the plug-in IFC-EXPORTER, selecting the version IFC 2x3 GSA BIM Design Concept 2010, which was able to export only the visible categories.



**Fig. 5:** Using Plug-in IFC-EXPORTER for the "filtering"

Completed filtering and exportation, the data were imported correctly in structural analysis software Axis VM to verify static and seismic calculations. At this step it was possible to verify the vertical intelligent interoperability, experiencing only minimal problems of reading data and the need to recalibrate the modeling elements to generate legible element from the target program easily.

The method used for such verification consists of reading the modeled elements by applying Solibri Model Checker, which identifies, isolates and allows reading individually all geometry created in Revit Architecture 2013, highlighting any problems of data loss.

To better understand the used methodology in this study can be referred to the recalibration of a vertical element (columns) of the school taken as a case study.

The columns in question, as well as other complex families in Revit can be modeled in two different ways: the *extrusion* for the architectural and the *adjustment analytical axes* for the structural elements.

Several problems have been found: (i) following the method of extrusion, the element was formed by a parallelepiped, constituting the load-bearing element, and by the relative shelf: in consequence, the section of the element was variable; (ii) the verification geometry creation, interpreting the element as a group of faces and not as an extrusion; finally, (iii) a further loss of information was about the size of the profile.

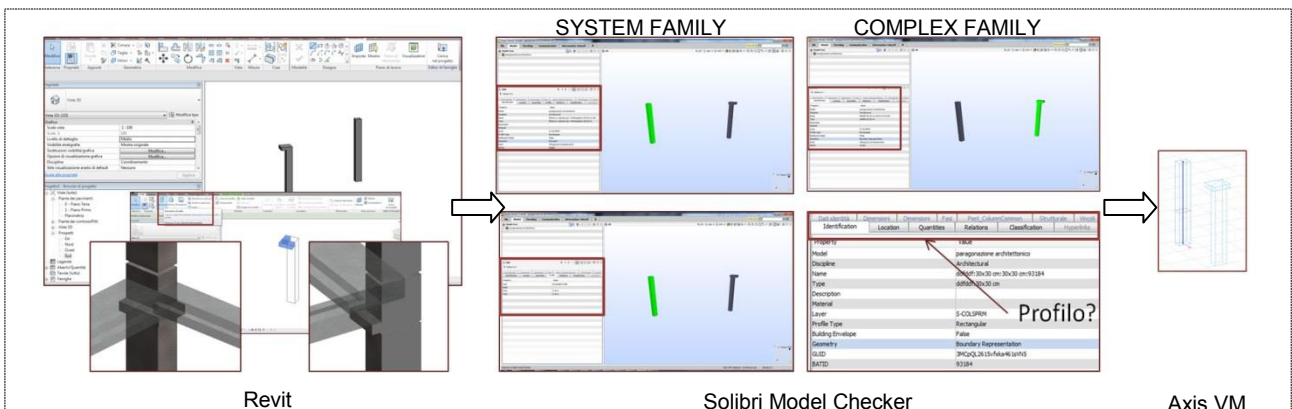

**Fig. 6:** Extrusion of architectural elements, the verification of them by Solibri Model Checker and import into Axis VM

In the procedure with the adjustment analytical of the axes, it was possible to align the analytical axes depending on the variation of the section. However, in Revit, going into IFC options, it can be noticed that the identity of the analytical column was not defined. Therefore, Axis VM lost the category and generated its axis on the center of gravity of analytical geometry.

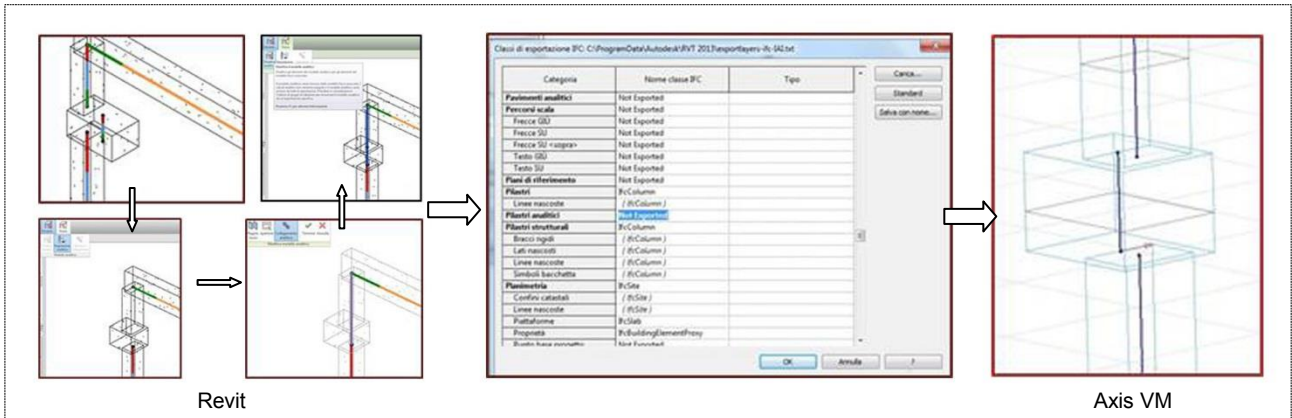

**Fig. 7:** Adjustment analytical axes for the structural elements and import into Axis VM

To overcome these problems, it was essential the calibration of the consisting model in a simplification of the element: for example, the column was decomposed into two simple elements with the aligned axes. Obviously, it was involved a difference between the geometric model and the actual situation. The important thing was to verify that this difference is irrelevant to the calculation.

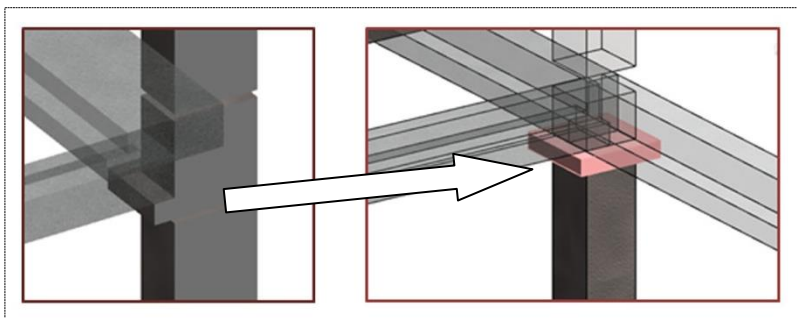
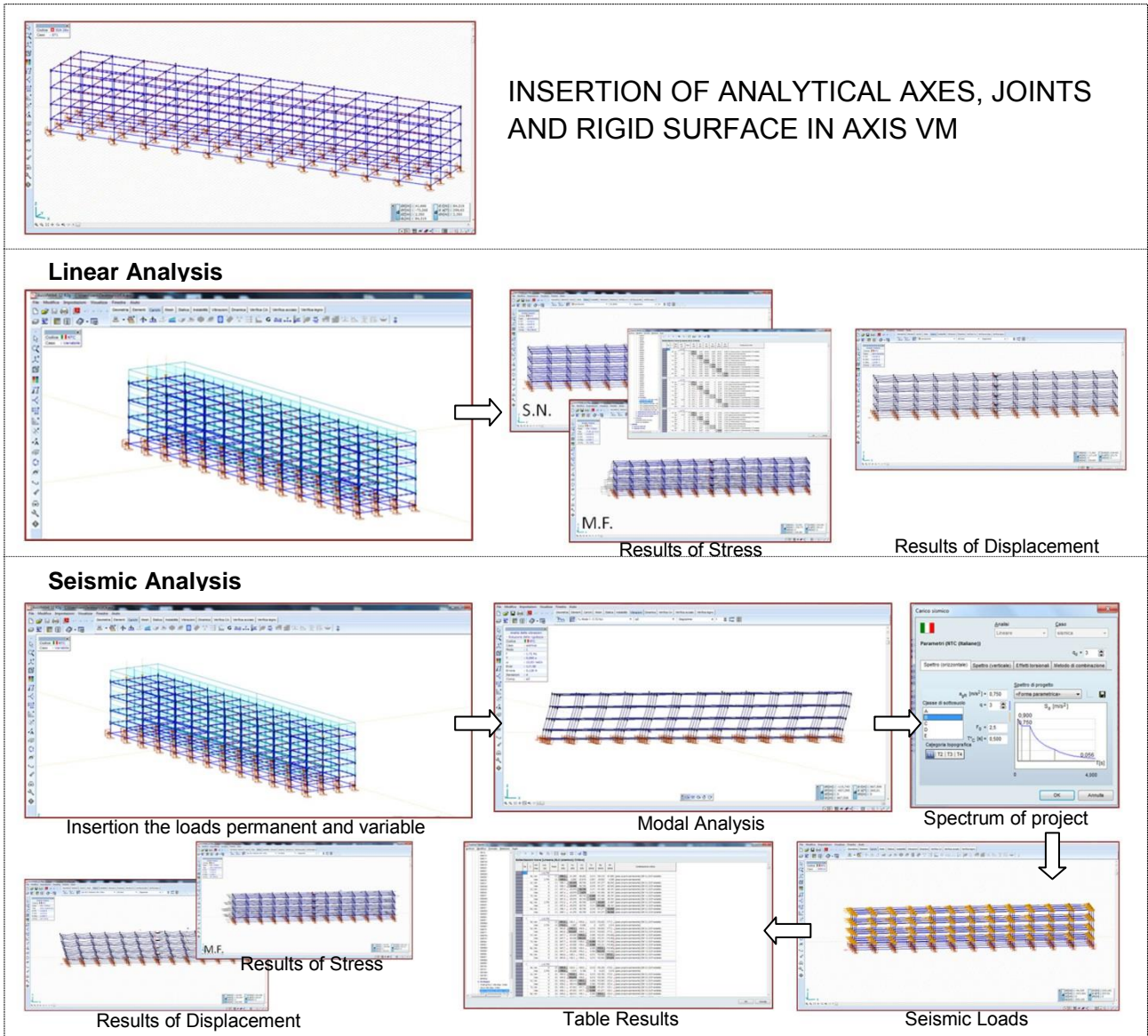

**Fig. 8:** Simplification of the element

### 2.3 To implement Static and seismic analysis and the verification of structural elements with possible modification of the geometry in Axis VM;

Fixed problems with reading of the desired element through the recalibration of the model, it was possible to perform calculations with Axis VM, which is a complete program for the finite element structural analysis of structures with each type of material.

The procedure of inserting analytical axes, joints and rigid surface in Axis VM was identical regardless of whether the file comes from Revit or Archicad. First, it was necessary to define the materials of columns and beams to set analytical axes on which were placed the loads. Subsequently, to specify the joints and rigid surface. After inserting the loads (permanent and variable), and applied linear analysis, results were obtained. These data were divided into the results of displacement and stress, and can be displayed in tables or graphs. Furthermore it was possible to perform the seismic analysis: in this case it was necessary to insert the loads (permanent and variable) to implement modal analysis, which was subsequently joined to the spectrum of project to obtain the seismic loads and the results of displacement and stress.



**Fig. 9:** Insertion of analytical axes, joints and rigid surface in axis vm, apply linear and seismic analysis

To verify the structural elements, in the Table Results was necessary to select the critical combinations among static and seismic ones to identify the element most stressed. For this element, it was proceed with the assignment of the resistance of materials values, with the placement of reinforcing bars (choosing diameter, number and position) and continue to verify. The interaction diagram of normal stress-moment was shown the domain of resistance element. All stress values (crosses) of static and seismic combinations should be included in that domain. Normally there were initially blue crosses (internal to the domain - checked) and red crosses (external to the domain - unverified). Based on these results it was necessary to modify the bar, the size of the section and the material until all combinations of stress values were within the domain of resistance (all blue crosses - checked)

The advantage of BIM interoperability is clear to all: it is not necessary search manually for the element and re-inserts the changes made by structural engineers, but the software automatically loads the calculated element in Axis VM and updates the possible choices, allowing the designer to choose between those that are more compatible with the project as a whole. Moreover, everyting starts from the 3D model that is much more than a simple 3D model because it is a digital representation of the project containing several data that can be exchanged thanks interoperability.

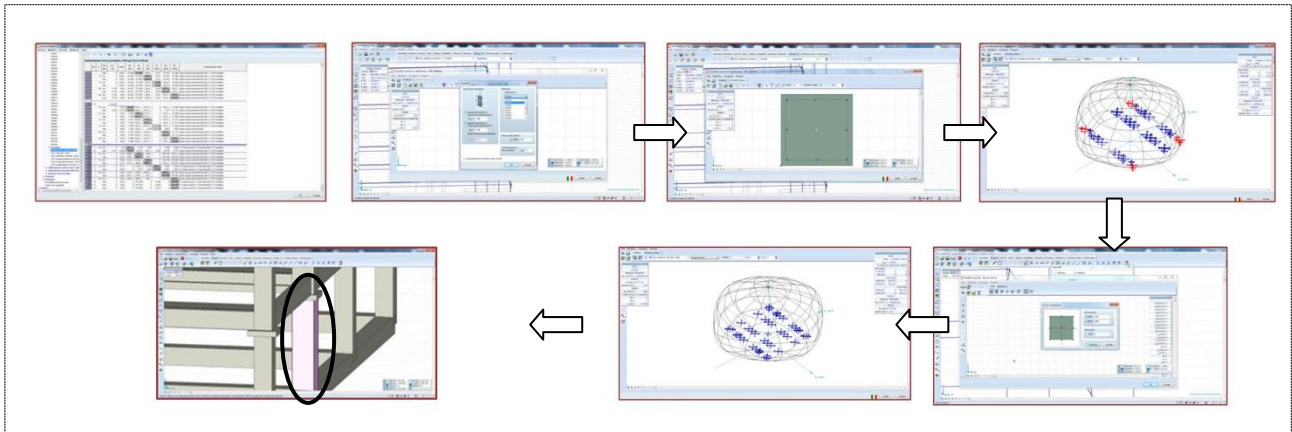

Fig. 10: Verification of structural element

### 2.4 Exporting modified geometry from Axis VM and imports it into Revit

Before importing the IFC file into Revit or ArchiCAD with the changes made in Axis VM, it was possible to verify with Solibri Model Checker that all information of the column were maintained, comparing the new IFC modified in calculation with those originally obtained from the parametric modeling software. In the case study described, of course, the check was performed with Solibri comparing old column information with those of the element being edited.

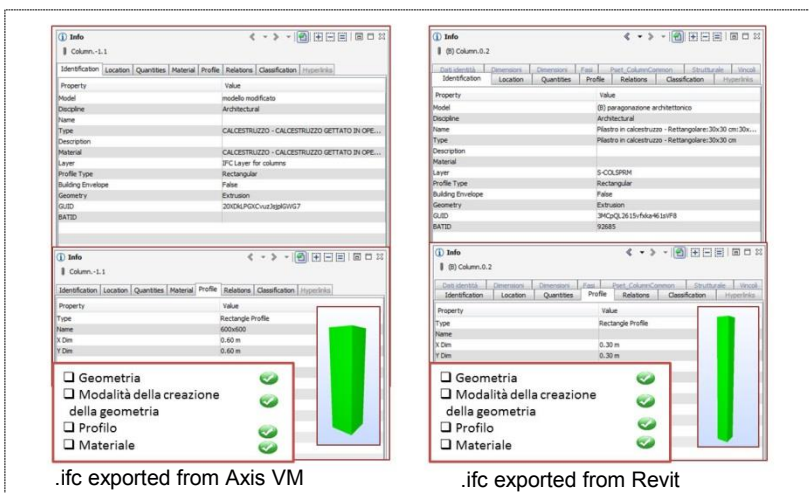

Fig. 11: Comparing the information of the original column with the modified one and verify with Solibri Model Checker

It must also verify that the information available in Solibri was maintained even in Revit and ArchiCAD. The structural element (in this specific case of the column) was imported into Revit with a *merge* of the single element on the original model. After this operation, frequently there was a loss of data taking into account the geometry, the profile and the material.

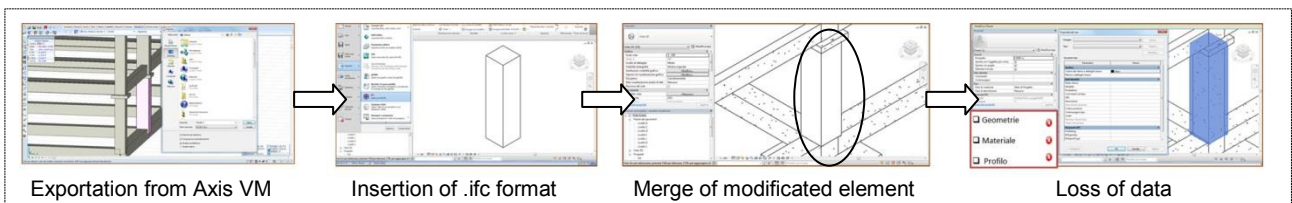

Fig. 12: Exportation from Axis VM and importation into Revit

## 2.5 Exporting modified geometry from Axis VM and imports it into Archicad, subsequently exports it from ArchiCAD and imports it into Revit

To ensure the maintenance of all the information it is essential to insert the element in the model. For example, it was possible to import the element from Axis VM in Archicad and, with the *detects changes IFC model* command to access the menu from which can be inserted the element with the section resized. At this point it was necessary to implement merge with the original model and check any data loss: Archicad displays in green all modified objects, while unchanged items remain blacks. Once, select *the changes into correction* command, the file is updated and all data can be checked simply by selecting the item.

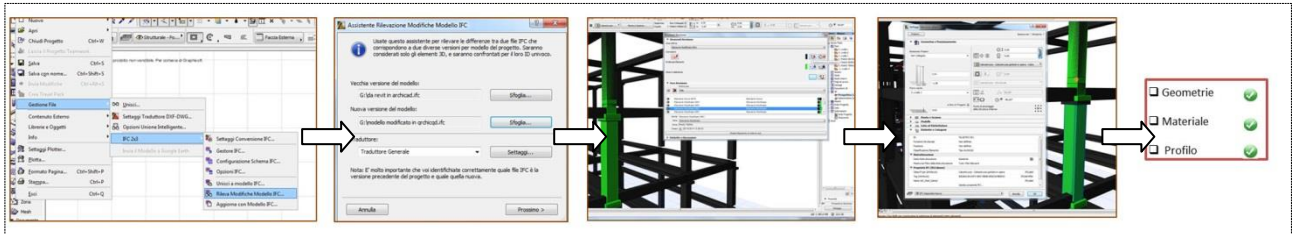

Fig. 13: Importation of the element from Axis VM into Archicad

The problems were found at the step by importing the element from Archicad in Revit using *the general translator* command. It was noticed that Revit couldn't interpret some information of .ifc files. Despite the created and edited elements in another program were designed and positioned correctly, they couldn't be associated with a Revit family and therefore couldn't be changed. Instead, these elements in Archicad, in addition to being positioned and designed properly, could be also edited.

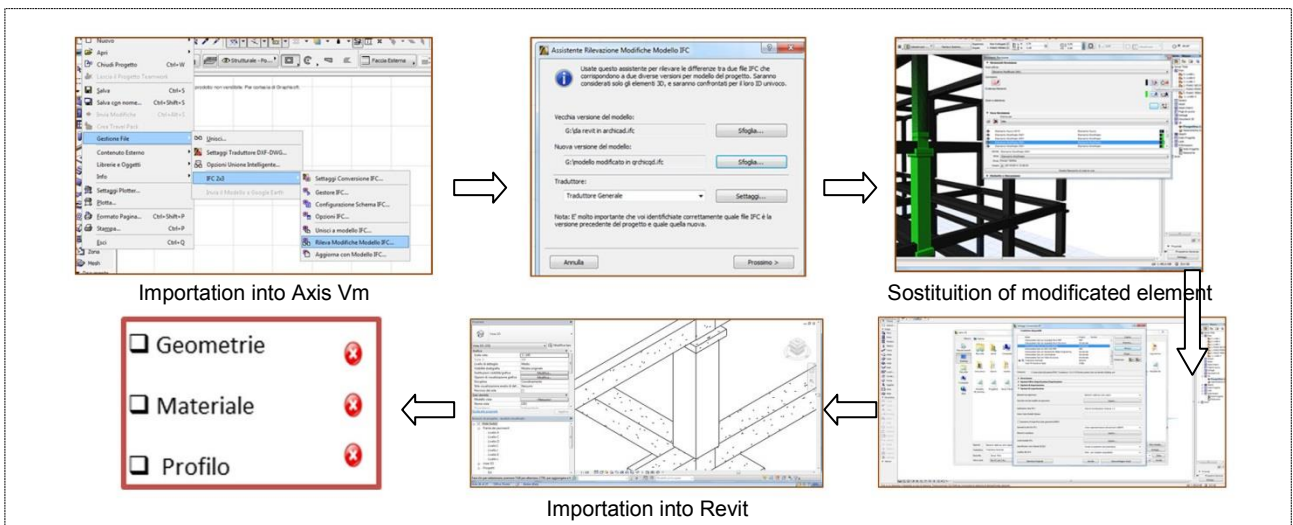

Fig. 14: Importation of the element from Archicad into Revit

This difference in behavior occurred because the IFC used a globally unique identifier (GUID) for all instances of objects. Solibri Model Checker reads exported elements from Axis VM through two GUIDs: Archicad GUID and IFC GUID. While Archicad was able to read both GUID, Revit had problems to read the GUID re-imported into the original model after effectual changes in Axis VM.

The problem can be overcome by developing an application that reads the data of the elements in the IFC file and converts them into Revit families system, thus improving the process of both vertical and horizontal interoperability.

## 3. Conclusion

As described above shows how the current state of interoperability would be very optimistic about the validity and potential of the method, although some steps have not yet automated in modeling, filtering and exporting information.

All of the problems detected by the current research, the most can be overcome with a good knowledge of the software for parametric modeling and the adoption of BIM workflow well defined from the beginning. In this way it is possible to identify in advance the necessary data for structural analysis and calibrate modeling through simplification schemes already known or easily deducible.

For other issues, particularly those relating to the GUID, the lack of analytical axes codes of Revit or loss of data due to the modeling of complex elements, instead, it should be a cooperative work of research and interdisciplinary development between developers, architectural designers and structural engineers.

### **Acknowledgments**

The research is funded by MIUR, and the interdisciplinary research is titled Built Heritage Information Modelling/Management (BHIMM)

### **Bibliographical References**

[1] EASTAM C., *Building Product Models: Computer Environments Supporting Design and Construction*, CRC Press, 1999.

[2] OSELLO A., *The Future of Drawing with BIM for Engineers and Architects*, Palermo, Dario Flaccovio Editore, 2012. ISBN 9788857901459.

[3] STABILE R., "*Il Building Information Modeling nella valutazione della sicurezza strutturale delle costruzioni in cemento armato esistenti: applicazioni ad un caso studio*", Master degree, Dept. Architecture, Università degli studi di Napoli "Federico II", Naples, IT.

[4] NUTI F., *Edilizia - Progetto/costruzione/ produzione*, Firenze, Edizioni Polistampa. 2010.

[5] SADEGHPOUR F., MOSELHI O., ALKASS S.T., *Computer Aided Site Layout Planning*, Journal of Construction Engineering and Management, 2005, vol. 132, No. 2, pp. 143-151.

[6] <http://www.autodesk.co.uk/adsk/servlet/pc/index?siteID=452932&id=14645193>

[7] <http://www.buildingsmart-tech.org>