

Building fan coil electric consumption analysis with fuzzy approaches for fault detection and diagnosis

*Original*

Building fan coil electric consumption analysis with fuzzy approaches for fault detection and diagnosis / Lauro, F., Moretti, F., Capozzoli, A., Khan, I., Pizzuti, S., Macas, M., Panzieri, S.. - In: ENERGY PROCEDIA. - ISSN 1876-6102. - STAMPA. - 62:(2014), pp. 411-420. [10.1016/j.egypro.2014.12.403]

*Availability:*

This version is available at: 11583/2588495 since:

*Publisher:*

Esevier

*Published*

DOI:10.1016/j.egypro.2014.12.403

*Terms of use:*

This article is made available under terms and conditions as specified in the corresponding bibliographic description in the repository

*Publisher copyright*

(Article begins on next page)



6th International Conference on Sustainability in Energy and Buildings, SEB-14

## Building fan coil electric consumption analysis with fuzzy approaches for fault detection and diagnosis

F. Lauro<sup>a,b,c,\*</sup>, F. Moretti<sup>b,c</sup>, A. Capozzoli<sup>a</sup>, I. Khan<sup>a</sup>, S. Pizzuti<sup>b,c</sup>, M. Macas<sup>d</sup>, S. Panzieri<sup>b</sup>

<sup>a</sup>TEBE Research Group, Department of Energy (DENEG), Politecnico di Torino, Corso Duca degli Abruzzi 24, 10129, Turin, Italy

<sup>b</sup>Roma Tre University, Computer Science Department, Via Della Vasca Navale 79, 00148, Rome, Italy

<sup>c</sup>Energy New technologies and sustainable Economic development Agency (ENEA), Via Anguillarese 301, 00123 Rome, Italy

<sup>d</sup>Czech Technical University, Department of Cybernetics, Zikova 1903/4, 166 36 Prague 6, Czech Republic

### Abstract

In the building energy efficiency field, developing automatic and accurate fault detection and diagnosis methods is necessary in order to ensure optimal operations of systems and to save energy. In this paper first, fault detection analysis based on statistical methods where anomalies are detected through a comparison with neighborhood and averaged fault-free values and through a clustering technique is performed. Following the fault detection step, a fault diagnosis analysis based on fuzzy sets and fuzzy logic is implemented. Experimentation is carried out over a one day monitoring data set in December 2013 for the fan coil electric consumption of an actual office building located at ENEA 'Casaccia' Research Centre. Results show the effectiveness of proposed approaches in automatic detection and diagnosis of abnormal building fan coil electric consumption.

© 2014 The Authors. Published by Elsevier Ltd. This is an open access article under the CC BY-NC-ND license

(<http://creativecommons.org/licenses/by-nc-nd/3.0/>).

Selection and peer-review under responsibility of KES International

**Keywords:** fan coils fault detection and diagnosis; fuzzy logic; abnormal building consumption; peak detection.

### 1. Introduction

Energy efficient management of building systems is a crucial issue in order to minimize energy consumption and costs. In particular, consumptions related to residential and commercial sectors in developed regions are estimated to 40% or more of final energy use annually [1]. Furthermore, heating, ventilation and air conditioning (HVAC) system

\* Corresponding author. Tel.: +390110904413; fax: +390110906329.

E-mail address: [fiorella.lauro@polito.it](mailto:fiorella.lauro@polito.it)

consumes 30% of the primary energy in Europe [2], 14% of the primary energy in the U.S. [3], and about 32% of the electricity generated in the U.S. [4]. Building energy system and the monitoring of its energy and environmental performance has been the subject of great interest in recent years. In Europe, member states have set an energy savings target of 20% by 2020, mainly through energy efficiency measures. A number of methodologies for optimizing real-time performance, automated fault detection and isolation were developed in Annex 25 [4].

HVAC systems provide building occupants with a comfortable and productive environment, and improving energy efficiency while maintaining the indoor environmental quality satisfactory is quite challenging. Building HVAC systems faults, including design problems, equipment and control system malfunction, and inappropriate operating procedures [5], result in energy waste and occupant discomfort. Well-managed HVAC systems results in an average savings of 5-15% of total energy consumption in full commissioning of existing buildings [6][7]. Many of diagnostic methods developed in Annex 25 were later demonstrated in real buildings in Annex 34 [8], which concentrated on computer-aided FDD. The application of simulation and optimization tools to solve a variety of energy management problems in HVAC system or building design problems is shown in the works of [9][10][11][12]. Air handling unit (AHU) is one of the important component in HVAC system, which is the heat exchange station between the air and water. AHUs directly influence the energy consumption of air conditioning systems as well as indoor air quality and thermal comfort in air-conditioned spaces. Therefore, fault detection and diagnosis (FDD) in AHUs also attracted intense research interests. Salsbury and Diamond [13] provided a practical algorithm for diagnosing control loop problems in an AHU. A method for the AHU sensor fault detection based on the principal component analysis (PCA) was elaborated in the work of [14]. Liang and Du [15] and Cho et al. [16] used statistical classifiers for their FDD tools. Many other approaches has been carried out on this task: Parvaresh et al. [17] proposed a Takagi-Sugeno fuzzy classifier, Du et al. [18] a Takagi-Sugeno-Kang fuzzy model, Dexter [19] based his approach on fuzzy matching and Dempster's rule of combination, Magoulès et al. [20] used RDP neural networks, Song et al. [21] and Schein et al. [22] developed tools based on a set of rules threshold-based.

In this paper, a hybrid statistical and inferential approach to diagnose employees improper use of fan coils of a tertiary building inside R.C. Casaccia is proposed. The major contents of this study are: 1) fault detection is performed on the collected 10 min timestamp data using peak detection and DBSCAN methods. In addition, Mzscore index is used to quantify the abnormal values detected through peak detection; 2) fault diagnosis using the fuzzy sets and fuzzy logic (fuzzyfication) is implemented. The organization of the paper is as follows. Sections 2 and 3, gives preliminaries that provide brief background knowledge on peak detection and DBSCAN methods respectively. In section 4, fuzzy theory used for diagnostics inference is discussed and section 5 presents the application of proposed approach, results and discussion. Conclusions based on results of this study constitute section 6.

## 2. Peak Detection Method

Identifying and analyzing *peaks* in a given time-series is important in many applications such as building energy consumptions. In order to avoid subjectivity and to devise algorithms for the automatic detection of peaks in any given time-series, it is important to define the notion of peak. A peak is defined as an observation that is inconsistent with the majority of observations of a data set. Not all local peaks are true peaks: a local peak is a true peak if it is a reasonably large value even in the global context.

The implemented method, *Peak Detection Method*, is based on the use of a *peak function*  $S$ , which associates a score with every element of the given time-series, proposed by [23]: a given point is a *peak* if its score is positive and it is greater or equal than a user-specified (or suitably calculated) threshold value. Particularly, the *peak function*  $S$  (eq. 1) computes the average of the maximum among the signed distances of a given point  $x_i$  in a time-series  $T$  from its  $k$  left neighbors and the maximum among the signed distances from its  $k$  right neighbors:

$$S(k, i, x_i, T) = \frac{\max\{x_i - x_{i-1}, x_i - x_{i-2}, \dots, x_i - x_{i-k}\} + \max\{x_i - x_{i+1}, x_i - x_{i+2}, \dots, x_i - x_{i+k}\}}{2} \quad (1)$$

$k$  is a user-specified integer and must be much smaller (e.g., 3 to 5) as more peaks are "thin". The  $S$  function is an

index that allows to quantify the severity of outliers and then provides information about the priorities for actions to be associated with each outlier.

In addition to the *S function*, another synthetic index is the *modified z score (Mzscore)*. This index is based on the distance and direction of each outlier compared to the average value of normal observations (observations that do not contain outliers). On the basis of outliers  $n_{out}$  identified with the method described above, it's possible to identify the set  $X$  of all values, the set  $X_{out}$  constituted by only anomalous values ( $n_{out}$ ), the set  $X_{non-out}$  constituted by only non-anomalous values ( $n - n_{out}$ ) and calculate mean  $\bar{x}_{rob}$  and standard deviation  $s_{rob}$  of vector  $X_{non-out}$ . The value of *Mzscore*  $z_m$  is calculated for each value, considering respectively outlier values (eq. 2) and not outlier values (eq. 3), in the following ways:

$$z_m = \frac{X_{out} - \bar{X}_{rob}}{s_{rob}} \quad (2)$$

$$z_m = \frac{X_{non-out} - \bar{X}_{rob}}{s_{rob}} \quad (3)$$

### 3. DBSCAN

Clustering is concerned with grouping together objects that are similar to each other and dissimilar to the objects belonging to other clusters. Density-based method is designed to deal with non-spherical shaped clusters and require the definition of a metric to compute distances between objects in the dataset. In this case study, distances between objects are measured by means of the Euclidean distance computed on normalized data. DBSCAN requires two parameters [24]: a real number ( $r$ ) and an integer number ( $minPts$ ) required to specify size of neighborhood and the minimum number of points respectively to form a cluster. DBSCAN is an iterative algorithm which iterates over the objects in the dataset, analyzing their neighborhood. It starts with an arbitrary starting point that has not been visited. This point's epsilon-neighborhood is retrieved, and if it contains sufficiently many points, a cluster is started. Otherwise, the point is labeled as noise. If a point is found to be a dense part of a cluster, its epsilon-neighborhood is also part of that cluster. Hence, all points that are found within the epsilon-neighborhood are added, as is their own epsilon-neighborhood when they are also dense. This process continues until the density-connected cluster is completely found. Then, a new unvisited point is retrieved and processed, leading to the discovery of a further cluster or noise. The 'Cluster 0' assigned by DBSCAN algorithm corresponds to points that are labeled as noise and/or outliers. These are the points that have less than  $minPts$  points in their epsilon-neighborhood. The effectiveness of the algorithm is strongly affected by the setting of parameters  $r$  and  $minPts$ .

### 4. Fuzzy Logic

Fuzzy modeling was originally proposed by [25] and has been further developed by several authors, including [26]. Fuzzy logic extends Boolean logic, replacing the true/false values with partial truth and consists of a set of production rules which define the relationship between the input and output variables [27]. Rules are of the form: "IF X is A THEN Y is B", where A is a fuzzy set over the input domain X and B a fuzzy set over the output domain Y.

If X is a collection of objects denoted generically by  $x$ , then a fuzzy set A in X is a set of ordered pairs:

$$A = \{ (x, \mu_A(x) | x \in X) \} \quad (4)$$

$\mu_A(x)$  is called the *membership function* (generalized characteristic function), which maps X to the membership space M. Its range is the subset of non-negative real numbers whose supremum is finite. For  $\sup(\mu_A(x)) = 1$  we have normalized fuzzy set, which are those commonly used. Therefore, in fuzzy sets the key task is the definition of the membership function (fuzzyfication). This can be any kind of analytical function whose parameters have to be

properly tuned according to the meaning of the fuzzy set itself. A fuzzy set operation is an operation on fuzzy sets. These operations are generalization of crisp set operations. There is more than one possible generalization. The most widely used operations are called standard fuzzy set operations. There are three operations: fuzzy complements, fuzzy intersections, and fuzzy unions.

The membership function of the intersection (logical and) of two fuzzy sets A and B is defined as:

$$\mu_{A \cap B}(X) = \text{Min}(\mu_A(X), \mu_B(X)) \quad \forall X \in X \quad (5)$$

The Intersection operation in Fuzzy set theory is the equivalent of the AND operation in Boolean algebra. The membership function of the union (exclusive or) is defined as:

$$\mu_{A \cup B}(X) = \text{Max}(\mu_A(X), \mu_B(X)) \quad \forall X \in X \quad (6)$$

The Union operation in Fuzzy set theory is the equivalent of the OR operation in Boolean algebra. The membership function of the complement (negation) is defined as:

$$\mu_{\neg A}(X) = 1 - \mu_A(X) \quad \forall X \in X \quad (7)$$

The complement operation in fuzzy set theory is the equivalent of the NOT operation in Boolean algebra.

## 5. Experimentation

### 5.1. Fault detection analysis

An actual office building located at ENEA Research Centre (Rome, Italy) was considered as a case study. In particular, the building is named "F40" and was built between 1970 and 1972 (see Fig. 1). The building is composed of three floors and is equipped with an advanced monitoring system aimed at collecting energy consumption (electrical and thermal) and the environmental conditions.



Fig. 1. F40 Building

Monitoring and actuation system developed is structured in five logical layers: fieldbus layer directly interface to sensor network through a building energy management system (BEMS), sensor and actuator layer containing applications that interface database of data warehouse layer with BEMS, application layer containing diagnostics and control logics applications, presentation layer that is a web interface to users.

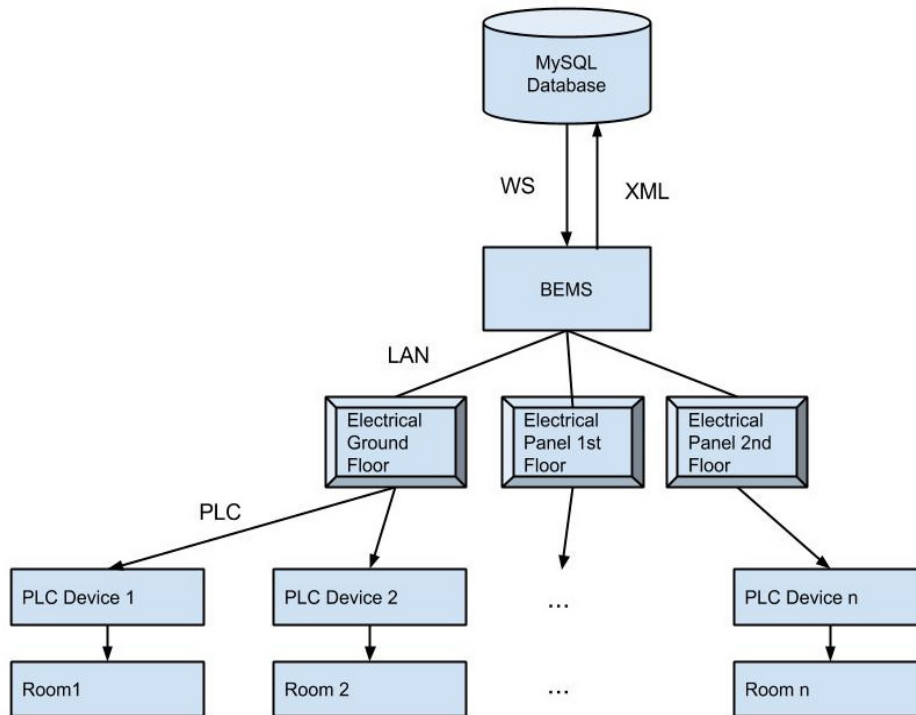

Fig. 2. Monitoring and acquisition system developed in F40 Building

The actual infrastructure is shown in Fig. 2: field sensors communicate with electrical panel through electrical line using power line communication (PLC) technology, which enables to commute electrical signals such that data can be carried on the same line. PLC devices modulates data from fieldbus sensors into electrical signals and demodulates into data again to electrical panel. Communication between electrical panel and BEMS server is handled within local area network (LAN). The acquisition phase is then completed by sensor layer, which retrieve data from BEMS in XML format and parse it into the database. Actuation phase is processed by actuator layer, that reads desired values to be set from a dedicated database table and communicates with BEMS through web services (WS).

Fan coil electric maximum power consumption of the building second floor was analyzed and considered in this experimentation with a 10 minutes time step. Furthermore, people presence and time of the day were recorded with a 10 minutes time step. On the second floor of the building F40 there are 20 fan coil units (see Fig. 3), characterized by an electrical power of 22 W, 28W, 40 W corresponding to the three possible speeds. At the time of testing, the switching on and off of fan coil units were fully manual. Thus, in this study the FDD analysis of fan coil units results in a occupant behavior diagnosis.

A dataset of about one day (22 December 2013 - 23 December 2013) was considered. In order to verify the reliability and the effectiveness of the proposed FDD approach, an “artificial” fault was created in the afternoon of Monday 23 December. In that day, between 14:00 and 14:40, with a low people presence, all the fan coil units of the second floor were switched on creating an anomalous peak of energy demand.

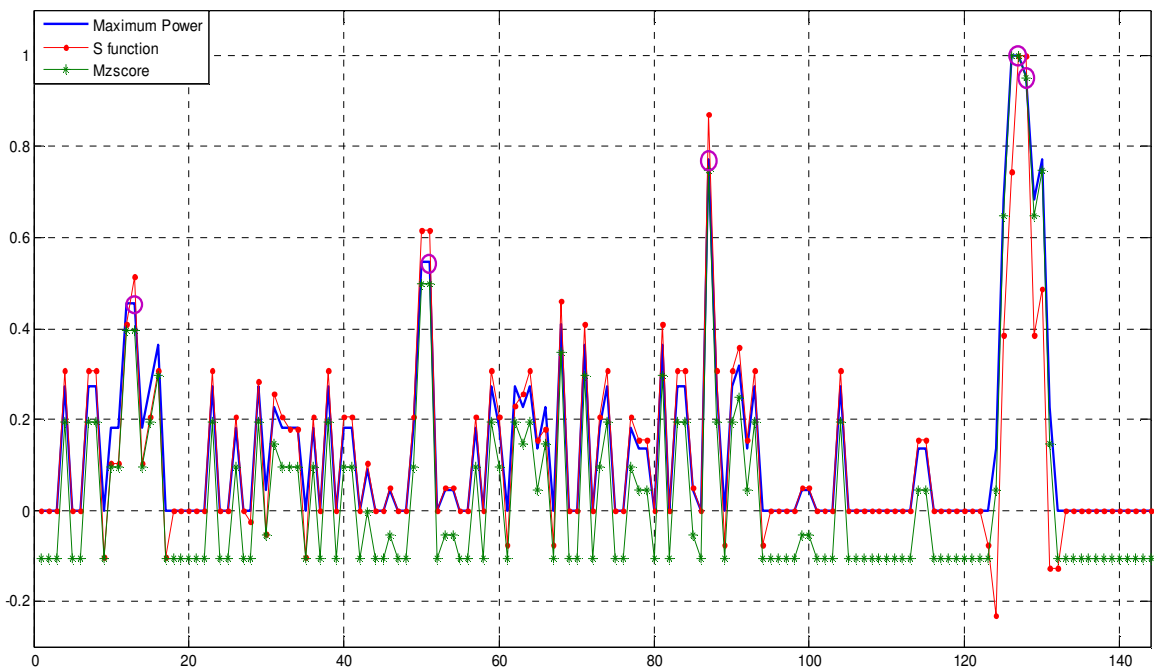

Fig. 3. Example of fan coil unit under examination

Fig. 4. Normalized maximum power consumption,  $S$  function and  $Mzscore$  indices and detected faults (circled)

The peak detection and the DBSCAN methods were applied to the sequence maximum power demand data for detecting faulty operation or anomalous values. In Fig. 4 the normalized maximum power consumption and the normalized trends of  $S$  function and  $Mzscore$  indices in the lattice  $[0,1]$  are reported: the severity indices correctly assume higher values in correspondence to the detected (circled) faults. Detected faults by peak detection and DBSCAN methods are reported in Table 1 and in Table 2 respectively.

Table 1. Fault detection results with Peak Detection Method. Parameters values used: k=4, h=1.

Time	Power (kW)	S function	Mzscore
22/12/2013 19:10	0.10	0.10	2.63
23/12/2013 01:30	0.12	0.12	3.30
23/12/2013 07:30	0.17	0.17	4.96
23/12/2013 14:10	0.22	0.20	6.63
23/12/2013 14:20	0.21	0.20	6.30

Table 2. Fault detection results with DBSCAN Method. Parameters values used: epsilon=0.5, minPts=5.

Time	Presence	Power (kW)	zPresence	zPower
23/12/2013 07:30	10	0.17	1.78	3.06
23/12/2013 12:00	5	0.03	0.61	0.01
23/12/2013 13:50	3	0.15	0.15	2.62
23/12/2013 14:00	2	0.22	-0.08	4.15
23/12/2013 14:10	2	0.22	-0.08	4.15
23/12/2013 14:20	2	0.21	-0.08	3.93
23/12/2013 14:30	2	0.15	-0.08	2.62
23/12/2013 14:40	2	0.17	-0.08	3.06

## 5.2. Diagnostic process with a fuzzy analysis

Finally, the experimentation concerned the application of the fault diagnosis method on the selected testing day is proposed. The fault diagnosis system is based on fuzzy sets and fuzzy logic. A fuzzyfication of low level signals and a fuzzy sets composition providing a real value, in the lattice  $[0,1]$ , capable of indicating the seriousness or the alarm degree (1 maximum alarm degree, 0 no alarm degree) of the detected fault with the cause under examination.

Thus, in order to characterize the diagnostics index for an anomalous fan coil electric consumption out of the working hours for the three floors of the building, the main criterion and process variables for the alarm degree of the detected fault have been defined. The main criterion is: "IF a fault in fan coil electric consumption occurs AND people presence in the floor is low AND NOT in working hours THEN the diagnostics index is high". In order to avoid fake faults, anomaly has to be detected by S-function, Mzscore and DBSCAN simultaneously.

In terms of fuzzy sets the diagnostic index can be translated in one of the two ways:

$$C1 = \min(S1, 1-S2) \quad (8)$$

$$C2 = w*S1 + (1-w)*S2 \quad (9)$$

where  $w$  is a real number in  $[0,1]$  (in the experimentation  $w = 0.7$ ),  $S1$  and  $S2$  are the situations:

- $S1 = \text{“a fault in fan coil electric consumption occurs”}$
- $S2 = \text{“NOT in working hours AND people presence in the floor”}$

which are defined as (see Table 3):

$$S1 = F1 \text{ AND } F2 \text{ AND } F3 \tag{10}$$

$$S2 = \text{NOT } F4 \text{ AND } F5 \tag{11}$$

Table 3. Fuzzy sets, linguistic values, membership functions and parameters.

Fuzzy set	Linguistic value	Membership function $\mu_{Fi}(x_i)$	Parameters
F1	“S function of peak detection is high”	Sigmoid	$c=0.05; t=0.01$
F2	“Mzscore of peak detection is high”	Sigmoid	$c=2; t=1$
F3	“Dbscan value is high”	Sigmoid	$c=1.5; t=0.5$
F4	“working hours”	Gaussian	$m=12; s=4$
F5	“people presence”	$y=x/p$	$p=18$

where  $p$  is the floor maximum presence (in particular  $p=18$  for the second floor of the building) and:

$$\text{Sigmoid} = \frac{1}{1 + e^{\frac{c-x}{t}}} \tag{12}$$

$$\text{Gaussian} = \exp(- (x-m)^2/2s^2) \tag{13}$$

In Table 4, the fault detection and diagnosis results on the testing day are reported.

Table 4. Fault Diagnosis results on the testing day.

Time	Power (kW)	People Presence	F1	F2	F3	F4	F5	S1	S2	C1	C2
22/12/2013 19:10	0.10	0	0.99	0.65	0.52	0.80	0.00	0.65	0.00	0.52	0.36
23/12/2013 01:30	0.12	0	1.00	0.79	0.72	0.97	0.00	0.79	0.00	0.72	0.50
23/12/2013 07:30	0.17	10	1.00	0.95	0.96	0.47	0.56	0.95	0.47	0.53	0.81
23/12/2013 14:10	0.22	2	1.00	0.99	0.99	0.14	0.11	0.99	0.11	0.89	0.73
23/12/2013 14:20	0.21	2	1.00	0.99	0.99	0.15	0.11	0.99	0.11	0.89	0.72

From Table 4 it can be observed that definition C1 (eq. 8) performs much better than C2 (eq. 9) because it provides higher alarm values (0.89) in the situations where power was too high with respect to the hour of the day

and the people presence percentage. In Fig. 5 the FDD index behaviour C1 (the red smooth line) with respect to the normalized power consumption and the normalized people presence, over the testing day, is reported.

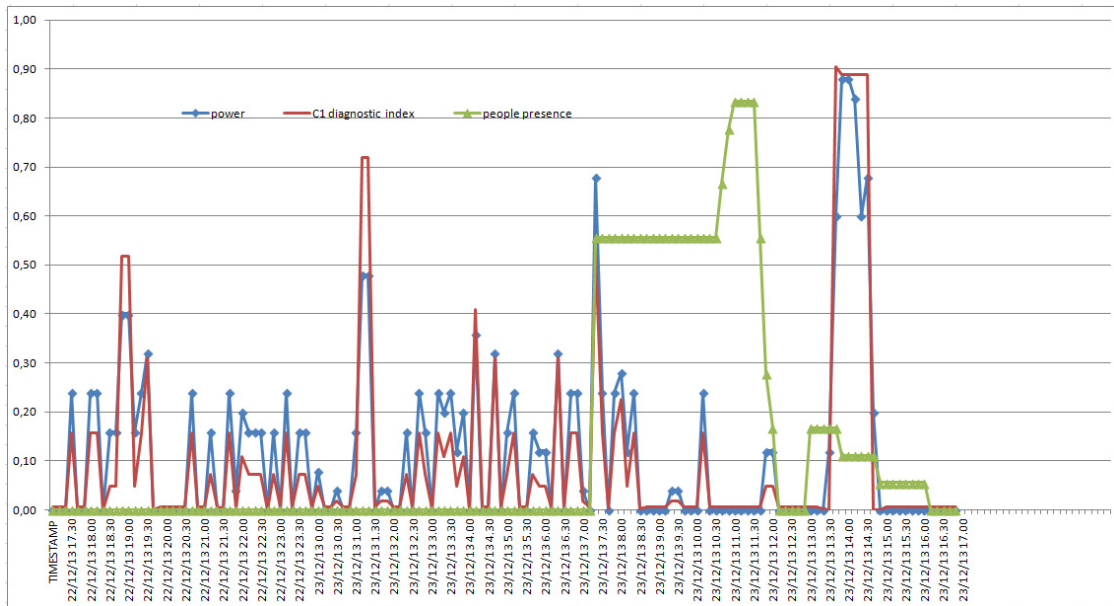

Fig. 5. FDD index behaviour with respect to the normalized power consumption and to the normalized people presence

## 6. Conclusions

In this paper a hybrid statistical, clustering and rule-based approach in order to diagnostic abnormal electric consumptions of fan coils caused by improper use by the employees is presented. The use of fuzzy rules allows exploitation of a-priori knowledge about the diagnosis going to be analyzed and enable to model easily input variables and to combine them together. Furthermore, aggregation of multiple fault detection techniques allowed a robust analysis, reducing fake faults risks. In the experimentation, two relationship rules for evaluation of the cause taken into account were compared. In the present work people presence data, time and electric power were considered. In a future work also meteorological data and thermal energy consumption related to fan coils will be taken into account.

## References

- [1] EIA. 2012. Annual Energy Review 2011. United States Energy Information Administration, Washington, DC, USA, DOE/EIA – 0384 (2011).
- [2] Laustsen, Jens. Energy efficiency requirements in building codes, energy efficiency policies for new buildings. International Energy Agency (IEA) (2008).
- [3] DoE, U. S. Buildings energy data book. Energy Efficiency & Renewable Energy Department (2011).
- [4] J. Hyvarinen, S. Karki. Building optimisation and fault diagnosis source book. IEA Annex (1996).
- [5] P. Haves , D. Claridge, M. Lui, Report assessing the limitations of EnergyPlus and SEAP with options for overcoming those limitations. California Energy Commission Public Interest energy Research Program, HPCBS #E5P2.3T1, 2001.
- [6] CIBSE Guide H: Building Control Systems. Butterworth-Heinemann. Oxford, 2000.
- [7] H. Friedman, M. A. Piette. Comparative Guide to Emerging Diagnostic Tools for Large Commercial HVAC Systems. Ernest Orlando Lawrence Berkeley National Laboratory, LBNL 48629, 2001.
- [8] Jagpal R, editor. Technical synthesis report, computer aided evaluation of HVAC system performance. IEA ECBCS Annex 34, 2001.

- [9] J.A. Wright, H.A. Loosemore, R. Farmani. Optimization of building thermal design and control by multi-criterion genetic algorithm. *Energy and Buildings*, 34 (2002) 959-972.
- [10] K.F. Fong, V.I. Hanby, T.T. Chow. HVAC system optimization for energy management by evolutionary programming. *Energy and Buildings*, 38 (2006) 220-231.
- [11] L. Lu, W. Cai, L. Xie, S. Li, Y.C. Soh. HVAC system optimization – in building section. *Energy and Buildings*, 37 (2005) 11-22.
- [12] T.I. Salsbury, R.C. Diamond. Fault detection in HVAC systems using model-based feedforward control. *Energy and Buildings*, 33 (2001) 403-415.
- [13] Salsbury, T.I., and R. Diamond. Model – Based Diagnostics for Air Handling Units. *Diagnostics for Commercial Buildings: Research to Practice*, 1999, San Francisco.
- [14] Wang, S.W., and F. Xiao. AHU sensor fault diagnosis using principal component analysis method. *Energy and Buildings* (36): 147–160, 2004.
- [15] J. Liang, R. Du. Model-based Fault Detection and Diagnosis of HVAC systems using Support Vector Machine method. *International Journal of Refrigeration*, (2007) 1-11.
- [16] S.H. Cho, H.C. Yang, M. Zaheer-uddin, Byung-Cheon Ahn. Transient pattern analysis for fault detection and diagnosis of HVAC systems. *Energy management and conservation*, 46 (2005) 3103–3116.
- [17] Parvaresh, A., et al. Fault Detection and Diagnosis in HVAC System Based on Soft Computing Approach.
- [18] Du, Juan, Meng Joo Er, and Leszek Rutkowski. Fault diagnosis of an air-handling unit system using a dynamic fuzzy-neural approach. *Artificial Intelligence and Soft Computing*, Springer Berlin Heidelberg, 2010.
- [19] Dexter, Arthur L., and Mourad Benouarets. Model-based fault diagnosis using fuzzy matching. *Systems, Man and Cybernetics, Part A: Systems and Humans*, IEEE Transactions on 27.5 (1997): 673-682.
- [20] Magoulès, Frédéric, Hai-xiang Zhao, and David Elizondo. Development of an RDP neural network for building energy consumption fault detection and diagnosis. *Energy and Buildings*, 62 (2013): 133-138.
- [21] Song, Young-hak, Yasunori Akashi, and Jurng-Jae Yee. A development of easy-to-use tool for fault detection and diagnosis in building air-conditioning systems. *Energy and Buildings*, 40.2 (2008): 71-82.
- [22] J. Schein, S.T. Bushby, N.S. Castro, J.M. House. A rule-based fault detection method for air handling units. *Energy and Buildings*, 38 (2006) 1485–1492.
- [23] Palshikar, G. K. Simple algorithms for peak detection in time-series. *Proc. of 1st Int. Conf. Advanced Data Analysis, Business Analytics and Intelligence*, 2009.
- [24] M. Ester, H.P. Kriegel, J. Sander, X. Xu. A density-based algorithm for discovering clusters in large spatial databases with noise. *Proceedings of the 2nd international conference on knowledge discovery and data mining*, 226-231.
- [25] Zadeh, L.A. Fuzzy sets. *Information and control*, 8, (1965): 338–353.
- [26] Sugeno, Michio, and Takahiro Yasukawa. A fuzzy-logic-based approach to qualitative modeling. *IEEE Transactions on fuzzy systems*, 1.1 (1993): 7-31.
- [27] Dubois, D., Prade, H. Towards fuzzy differential calculus: part 1 integration of fuzzy mappings; part 2: integration of fuzzy intervals; part 3: Differentiation. 8:1–17; 105–116; 225–233.