

POLITECNICO DI TORINO
Repository ISTITUZIONALE

The Italian research project ROAD-NGN 'Optical frequency/wavelength division multiple access techniques for next generation networks'

Original

The Italian research project ROAD-NGN 'Optical frequency/wavelength division multiple access techniques for next generation networks' / G., Cincotti; P., Boffi; G., Maier; E., Ciaramella; L., Valcarengi; Gaudino, Roberto; F., Matera; A., Mecozzi; M., Santagiustina; F., Vatararo. - STAMPA. - (2013), pp. 1-4. (Intervento presentato al convegno FOTONICA 2014 tenutosi a Milano, Italy nel 21/23 maggio 2013).

Availability:

This version is available at: 11583/2555744 since:

Publisher:

AEIT

Published

DOI:

Terms of use:

This article is made available under terms and conditions as specified in the corresponding bibliographic description in the repository

Publisher copyright

(Article begins on next page)

The Italian research project ROAD-NGN ‘Optical frequency/wavelength division multiple access techniques for next generation networks’

G. Cincotti,

Engineering Department, University Roma Tre, Roma

P. Boffi, G. Maier

Department of Electronics and Information Politecnico di Milano, Milano

E. Ciaramella, L. Valcarengi

Istituto TeCIP, Scuola Superiore Sant’Anna, Pisa

R. Gaudino

Dipartimento di Elettronica, Politecnico di Torino, Torino

F. Matera

Fondazione Ugo Bordoni, Roma

A. Mecozzi

Department of Physical and Chemical Sciences, University of L’Aquila, L’Aquila

M. Santagiustina

Department of Information Engineering, University of Padova, Padova

F. Vatalaro

Department of Enterprise Engineering, University of Rome Tor Vergata, Roma

The paper describes the activities of the Italian national research project ROAD-NGN ‘Optical frequency/wavelength division multiple access techniques for next generation networks’; the project aims to investigate and experiment new technological solutions to facilitate the migration of access systems from copper to optical fibre, and to help the integration with broadband wireless architectures, with particular interest for the backhauling of the fourth generation (4G) Long Term Evolution (LTE) networks. The approaches, based on the orthogonal frequency division multiplexing (OFDM) and wavelength division multiplexing (WDM) techniques, can enable the unbundling of the local loop (ULL) and are upgradable toward very ultra wideband systems.

1. Introduction

Europe 2020 strategy has underlined the importance of broadband deployment to promote social inclusion and competitiveness. It restated the objective to bring basic broadband to all Europeans by 2013 and seeks to ensure that, by 2020, all citizens have access to much higher internet speeds of above 30 Mb/s and 50% or more of households subscribe to internet connections above 100 Mb/s. The new broadband access network is a strategic infrastructure for the sustainable development of our Country. There are different available technological solutions for Next Generation Access Network (NGAN) development which companies need to evaluate in making investment decisions and adopt the approach more in line with existing installations and market conditions. However, nowadays, Point to Multipoint (P2MP) architecture, implemented through Passive Optical Network (PON) is obtaining the favor of almost all the main European operators. PON systems present some advantages, such as the absence of electrical power supply in the primary and secondary links and the reduced operational costs; however, the bandwidth resources are shared among multiple users, which access the network in a centrally controlled fashion. In addition, PON tree architecture does not allow a fair competitive evolution of the telecom market; particularly for alternative operators, since it is difficult to grant the Unbundling Local Loop (ULL), in the same way as it is possible in the existing point to point (P2P) copper-based networks.

2. Project aims

The ROAD-NGN project aims to investigate and experiment new technological solutions based on electrical Orthogonal Frequency Division Multiplexing (OFDM), all-optical OFDM, and Wavelength Division Multiplexing (WDM) technologies to enable the ULL in future Italian

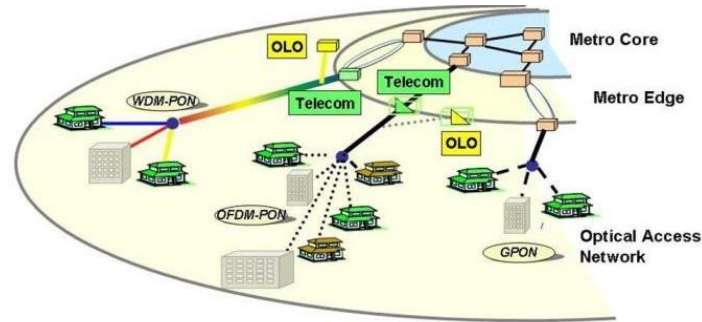

Figure 1 The ULL using OFDM or WDM approaches.

optical networks, also with test-bed demonstrations. These new approaches can provide bandwidth-variable and highly spectrum-efficient systems, with scalable and flexible sub- and super-wavelength granularity, for an effective use of the resources. OFDM and WDM technologies allow a form of opening of the infrastructure as different subcarriers and/or wavelengths can be uniquely associated to an operator and/or a service, such as television broadcasting, or even to a single user, enabling the sharing of the physical medium, with flows separation and complete management autonomy. Moreover, these systems can be implemented over already deployed fibre networks, as it is shown in Fig. 1.

Different methods of assigning OFDM subcarriers and WDM wavelengths are evaluated in the project, as well as procedures for a possible change of network operator; we investigate techniques to convey broadcast and multicast services, the transmission of High Definition (HD) television signals, the migration from existing copper-based solutions, the energy consumption for 'green' solutions...The regulations established by the Italian Communications Authority (AGCOM) are taken into account, in terms of architectures, services and ways of granting unbundled access. The optimal sharing of the existing infrastructures and an efficient access management will allow the deployment of a national NGAN compatible with the European Digital Agenda.

The ROAD-NGN project also includes, as a case-study, the new optical access network of the old historical downtown of L'Aquila, which still is to be rebuilt after the destructive earthquake of April 6th 2009.

3. Electrical OFDM systems

OFDM is a multicarrier modulation technique adopted in a large set of high-impact applications, as Digital Subscriber Line (DSL), Digital Video Broadcasting-Terrestrial (DVB-T), as well as wireless 4G LTE systems, and it recently became one of the hottest research topics in high-speed optical communications. One of the main goals of the ROAD-NGN project is the introduction of the OFDM approach in PON systems, also in conjunction with WDM techniques, that have been more extensively investigated. The joint use of OFDM and WDM techniques in access networks has an enormous potential, for both physical transmission and multiple access management. The sub- and super-wavelength bandwidth granularity allows an efficient resource utilization and the use of signal processing techniques, like equalization, that can largely enhance the system performances. Moreover, both techniques provide large flexibility, scalability and transparency to modulation format and bit rate; they allow to easily handle bursty traffic in PON systems and to support the coexistence of multiple services over a single platform. Finally, in OFDM- and WDM-based networks, Other Licensed Operators (OLO) can access the infrastructure with their own optical or radiofrequency subcarriers or wavelengths, which can be assigned to multicast or broadcast services, in a fully unbundled scenario also for P2MP networks.

In the ROAD-NGN project, novel radiofrequency OFDM-based access systems, that enable the ULL, are investigated and characterized. Different OFDM subcarriers can be assigned to different users and each subcarrier could be further shared in the time domain among many ONUs, implementing a two-dimensional partition of the bandwidth, as shown in Fig. 2.

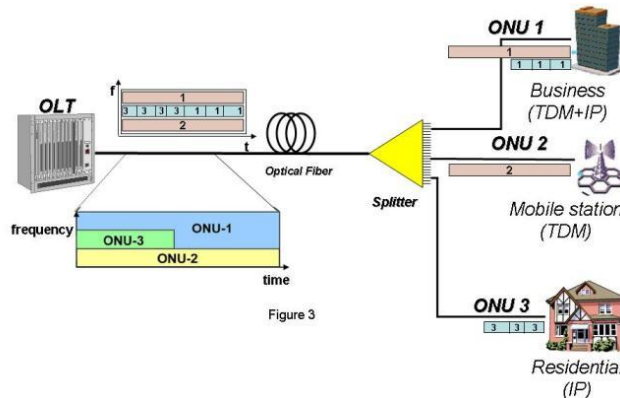

Figure 2 PON system based on electrical OFDM.

Alternatively, subcarriers can be statically or dynamically assigned to different service providers, with a large degree of flexibility. System performance are evaluated in terms of maximum number of users, bit-rate, spectral efficiency, maximum reach, electrical power consumption, Service Level Agreement (SLA) compliance, fairness in the resources sharing by the different operators/providers, robustness to chromatic and polarization dispersion and non-linearities...OFDM subcarriers and time-slots assignment methods and management protocols for peer-to-peer and broadcast services. Power consumption, performances for multimedia traffic transport and resilience in a failure event are also carefully analyzed. In addition, an experimental test bed, operating in C band, for radiofrequency OFDM signal distribution will be set up.

4. All-optical OFDM systems

PON systems based on all-optical OFDM technique are also investigated. The OFDM subcarriers are (de)multiplexed in the optical domain and they can deliver downstream and upstream traffic at 10, 2.5 and 1.25 Gb/s. Each subcarrier can be assigned to a specific user, an operator or a service provider. The optical Fourier transform (i.e. subcarriers (de)multiplexing) is implemented by an encoder/decoder (E/D) that can be placed either at the Remote Node (RN) (Fig. 3a) or at the Optical Network Units (ONU) (Fig. 3b). Multiple Input Multiple Output (MIMO), pilot tone and training sequence techniques are studied in the optical domain, as well as optical and electrical methods for chromatic dispersion compensation.

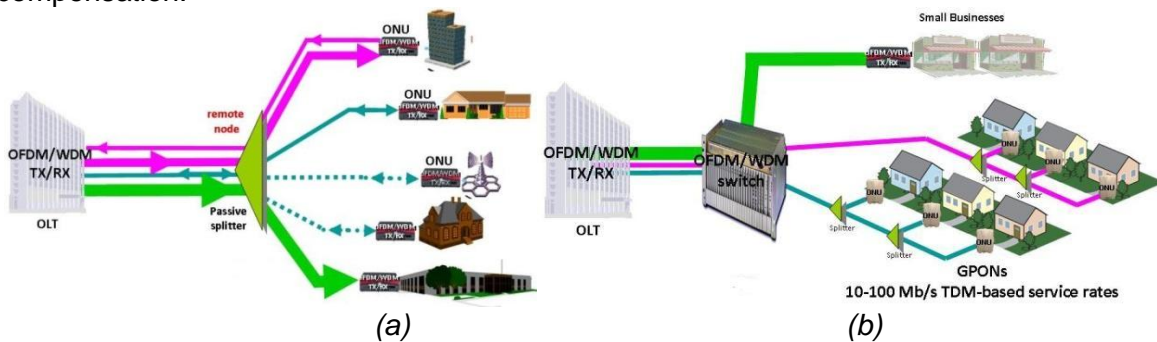

Figure 3 (a) PON system with E/D in the ONUs. (b) PON system with E/D in the RN.

5. WDM systems

In WDM-based PONs, different wavelengths can be assigned to different operators to carry aggregated time division multiple access (TDMA) channels, and/or they can be assigned to different services or users, as it is shown in Fig. 4.

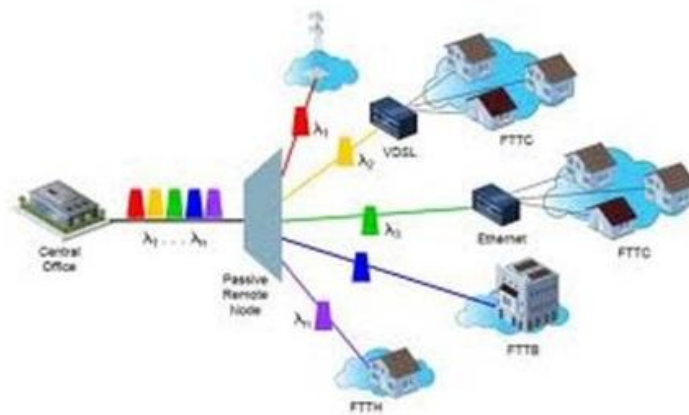

Figure 4 PON system based on WDM.

Different implementations will be considered, focusing on the reduction of ONU cost and complexity. A bidirectional optical system (1310/1550 nm) will be set up, for 10 Gb/s transmission using both power splitters and an Arrayed Waveguide Grating (AWG) in the RN. Dense and ultra-dense WDM solutions will be characterized with homodyne or heterodyne detection. The use of tuneable lasers is also considered as well as all the possible solutions for colorless operations. Advanced modulation formats will be also experimentally tested, as long as Digital Signal Processing (DSP) techniques. A test bed for a WDM transmission system operating in C-band, based either on wavelength-reuse or self-seeding approach will be also set up, removing the need for colored interfaces. Experiments will be carried out for off-line and active monitoring, based on the multi-wavelength Optical Time Domain Reflectometer (OTDR) technique.

5. Conclusions

The main research outcome of the ROAD-NGN Project will be the design, the performance analysis and the experimental characterization of new PON architectures based on frequency or wavelength division multiplexing techniques, which can allow the ULL in the physical layer, according to the AGCOM recommendations. New solutions will be proposed to promote the migration from existing copper-based networks to NGANs and new configurations will be analyzed for the convergence with wireless systems, also for the backhauling of 4G mobile networks.

The key innovation that the ROAD-NGN project purports to bring to optical access networks is the use of OFDM and WDM techniques as bandwidth-variable and highly spectrum-efficient systems, that can provide scalable and flexible sub- and super-wavelength granularity, compared to the conventional PON systems, to make an effective use of resources and allow different operators to share the same infrastructure. The combined use of the two techniques, in a hybrid OFDM-WDM-based PON would largely enhance the system performance, with a large flexibility and relevant overall traffic capacity.

In addition, the optical fiber links and devices will be also experimentally analyzed to evaluate the power loss, the effects of chromatic and polarization dispersion and of non-linearities. New techniques able to dynamically adapt the energy consumption to system capacity are also investigated, and new monitoring techniques are also proposed, both at setup (offline) and runtime (active monitoring).