

Experimental Analysis of an Advanced Dynamic Glazing Prototype Integrating PCM and Thermotropic Layers

Original

Experimental Analysis of an Advanced Dynamic Glazing Prototype Integrating PCM and Thermotropic Layers / Goia, Francesco; Bianco, Lorenza; Cascone, Ylenia; Perino, Marco; Serra, Valentina. - In: ENERGY PROCEDIA. - ISSN 1876-6102. - ELETTRONICO. - 48:(2014), pp. 1272-1281. [10.1016/j.egypro.2014.02.144]

Availability:

This version is available at: 11583/2538727 since:

Publisher:

Elsevier

Published

DOI:10.1016/j.egypro.2014.02.144

Terms of use:

This article is made available under terms and conditions as specified in the corresponding bibliographic description in the repository

Publisher copyright

(Article begins on next page)



SHC 2013, International Conference on Solar Heating and Cooling for Buildings and Industry
September 23-25, 2013, Freiburg, Germany

Experimental analysis of an advanced dynamic glazing prototype integrating PCM and thermotropic layers

Francesco Goia^{a,b,*}, Lorenza Bianco^b, Ylenia Cascone^b, Marco Perino^b, Valentina Serra^b

^a*The Research Centre on Zero Emission Buildings, Faculty of Architecture and Fine Arts, Norwegian University of Science and Technology, Alfred Getz vei 3, Trondheim 7491, Norway*

^b*TEBE Research Group, Department of Energy, Politecnico di Torino, Corso Duca degli Abruzzi 24, Torino 10129, Italy*

Abstract

Glazing components are the most challenging element of the building envelope system. The insertion of a Phase Change Material coupled with a thermotropic layer is herewith proposed as an innovative solution aimed at improving the energy performance of the fenestration. The intention is to increase the dynamic features of glazing systems and to enhance their capability of exploiting solar energy – a crucial feature in nearly Zero Energy Buildings.

The paper presents the experimental analysis of two prototypes of such a glazing concept and the assessment of their energy performance during the warm season. The samples are installed on an outdoor thermostatic cell facing south, together with a reference triple glazed unit, and continuous measurements of temperatures, irradiances and heat fluxes are performed. In the summer season, when the aim of the glazing system is to reduce the solar gain and to allow daylighting the energy performance is very promising. When compared to the reference technology, both the prototypes are able to reduce to a great extent the direct transmitted solar energy, as well as to smooth the peak indoor surface temperature of the glazing. In particular, one of the two configurations lowers down the solar energy gain under all boundary conditions, while the other configuration presents a slightly worse performance than the other prototype when high solar irradiation occurs. An attempt to measure the thermal transmittance was also carried out and it is shown that the insertion of PCM does not increase the *U-value* of the component.

© 2014 The Authors. Published by Elsevier Ltd.

Selection and peer review by the scientific conference committee of SHC 2013 under responsibility of PSE AG

Keywords: advanced glazing systems; dynamic building envelope components, PCM, thermotropic glass, experimental analysis

*Corresponding author. Tel.: +47-73-550275; fax: +47-73-595094 / Tel.: +39-011-0904519; fax: +39-011-090-4499.
E-mail address: francesco.goia@ntnu.no / francesco.goia@polito.it

1. Introduction

In this paper, the first results of experimental analyses on innovative glazing systems are presented. This work is the continuation of a previous research activity [1–5] on the potentials (and limitations) of window systems that incorporate a Phase Change Material (PCM).

This glazing concept originated in the late Eighties was seldom investigated in the following twenty years. The aim of integrating a PCM into glazing component is to enhance renewable energy exploitation at a building scale by both using solar energy in a more efficient way and reducing the time mismatch between solar energy availability and heating/cooling energy demand. Due to the spectral properties of some PCMs (e.g. paraffin wax), the insertion of such a layer in a transparent component allows the visible part of solar radiation to enter the indoor environment – for daylighting purpose – and most of the infrared radiation to be absorbed and stored within the glazing – with the aim of reducing heating/cooling load. As far as the latter aspect is concerned, due to the large amount of energy necessary to change the phase of aggregation, the density of energy that can be stored (mostly solar irradiation), at an almost constant temperature thanks to the exploitation of the latent heat of fusion of the PCM, is much higher than conventional glazing components. The expected benefits of PCM windows on the thermal balance of the building thus include:

- a reduction and shift of the solar heat gain through the glazing during the summer days, with a correspondent decrease in cooling load and cooling energy demand;
- a reduction in the “mismatch” between the heating demand and the availability of solar energy during winter time thanks to the buffering effect.

Moreover, this type of technology also presents advantages as far as thermal and visual comfort are concerned:

- a better control of the visible solar radiation and a reduction in the glare risk (improved exploitation of daylighting and visual comfort);
- a “mitigation” of the internal glass surface temperatures, which leads to an improvement of thermal comfort. A reduction in the “mismatch” between the heating demand and the availability of solar energy during winter time thanks to the buffering effect.

A detailed literature review of the developed and tested PCM glazing system configurations goes beyond the scope of this paper and cannot be herewith reported for the sake of brevity; a brief yet exhaustive state of the art of this class of technology can be found in [2,5]. However, for the purpose of this paper, it is important to point out that research and development in this field has proved the PCM glazing concept to be effective only when some conditions are realized. In particular, based on the outcome of the activities presented in [1,3,5–7], the following considerations can be done:

- the control on the “charge” phase of the PCM layer is necessary to prevent unwanted overheating phenomena (due to the complete melting of the PCM)
- the control on the “discharge” phase is also necessary to avoid either unwanted heat loss (in winter time) or unwanted heat gain (in summer time).

The control on the “charge” phase of the PCM layer is of particular relevance. Both the first prototypes [6] and commercially available products [8] present strategies to achieve this function. These strategies are external roller blind and prismatic glass, respectively. As far as the control on the “discharge” phase is concerned, focus was placed in avoiding unwanted heat loss towards the outdoor by adding a Transparent Insulation Material (TIM) on the outer side of the PCM glazing [7]. Such a configuration is an optimized solution for the winter season, but overheating phenomena might occur in summer if the TIM-PCM glazing system were adopted in climates where high solar gains and cooling loads occur.

Starting from the first-hand experience gained on the analysis of a simple PCM glazing prototype [1,5], a new PCM glazing concept has been conceived and tested. The main aim of this system was to improve the performance

of such a fenestration concept by increasing the responsiveness to solar radiation in order to achieve a better control on the “charge” phase of the PCM layer.

For this purpose, a thermotropic (TT) layer was included in the PCM window. A TT+PCM glazing system was obtained. In this component, the TT layer is asked to dynamically control the transmitted irradiance that impinges on the PCM layer so that the complete melting of the PCM layer can be avoided. Moreover, a triple glazed configuration was adopted in order to increase the thermal resistance of the system – a weak spot of the previously tested simple prototype [1]. In this case, the position of the PCM layer becomes not straightforward (either in the outermost or in the innermost cavity) and has deep implications on the thermo-physical response and energy performance of the system – as shown in [3]. Therefore, the layer structure of the TT+PCM glazing concept is also investigated in this paper, where the summer energy performance assessment of two different configurations of such a window system is presented alongside with the analysis of their the thermo-physical behaviour.

2. Prototypes and materials

The glazing prototype, thanks to the combination of the two advanced PCM-TT layers, is expected to provide a better control on solar energy transmission, to present an increased thermal inertia (due to the higher latent heat of the advanced PCM) and thus to simultaneously act as solar shading device, storage medium and glazing surface temperature moderator. In particular, with respect to the simpler prototype previously investigated [1,5], the adoption of the TT layer is expected to improve its performance by means of a better regulation of the charge phase of the PCM layer – thanks to a dynamic control of the solar transmission. In fact, when the temperature of the PCM glazing increases due to absorption of solar irradiation, the transmittance of the TT layer is naturally reduced, without the need of external energy sources. This change in the optical properties is mostly due to the increased back-scattering effect of the particles contained in the TT layer, which switch from an “off” phase to an “on” phase.

The thermotropic (TT) glass [9] is based on a polymer layer that contains core/shell particles homogeneously dispersed in a UV-cured resin. The particle core consists of an n-alkane mixture that is responsible for the temperature-induced switching of the optical properties. Below the switching point, the refractive indices of the resin, of the particle core and of the particle shell are (almost) equal and scattering is minimal. During the phase change, only the refractive index of the particle core changes significantly, so that the scattering occurs predominantly at the core/shell interface. In this way, by acting on both the density of core/shell particles in the matrix and on the particles dimension and composition it is possible to tune the properties of the TT layer. The TT layer thus shows, when the phase change of the particle core is completed, a significant increase in the solar (and visual) reflectivity due to back-scattering effect, and a consequent reduction in the transmittance.

The schematic representation of the TT+PCM glazing configurations is presented in Fig. 1. Two systems were developed: TGU_TT+PCM(IN) and TGU_TT+PCM(OUT) in order to assess the influence of the position of the PCM layer on the energy performance of the glazing. The two configurations share the same elements but the PCM layer is placed inside a different cavity – in the innermost and in the outermost, respectively. For practical reason, a basic triple glazed unit (TGU) was first realized and one of the cavities later filled with PCM. The basic TGU was made of a triple glazed unit, 1.40 m long and 0.75 m high, made of glass panes, where one of the cavities is filled with PCM and the other one is filled with Argon. The two glass surfaces facing the Argon-filled cavity were coated with a low emittance layer. The thermotropic layer was just placed, in direct contact, in front of the TGU, so that it was possible to test the two configurations with just one prototype: during the first part of the activity, the TGU_TT+PCM(IN) was tested; after approximately six months, the TGU was turned (placing the PCM-filled cavity towards the outdoor), the TT glass positioned again in front of the TGU (on the outdoor side), thus realizing the TGU_TT+PCM(OUT) to be tested.

. Table 1 Visual and solar properties (normal-hemispheric mode) of the TT glass technology in different state of the TT layer – *off*: below the switching temperature; *on*: above the switching temperature range (layout: 2x1mm clear glass and resin layer ~ 1.7 mm) [10]

Visual transmittance		Solar transmittance		g-value	
<i>off</i>	<i>On</i>	<i>off</i>	<i>on</i>	<i>off</i>	<i>on</i>
0.69	0.35	0.69	0.41	0.78	0.58

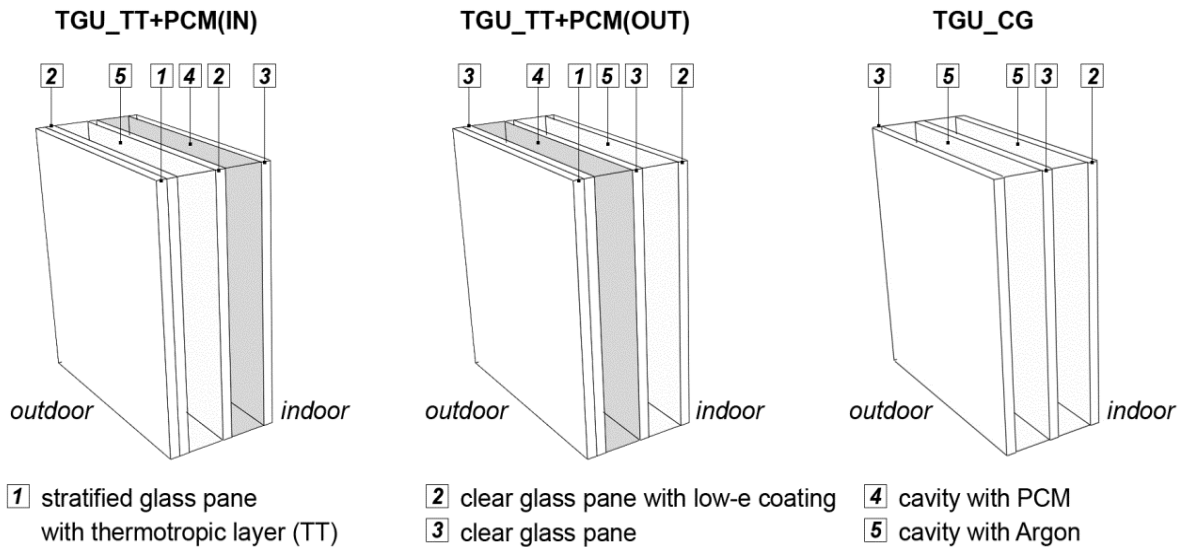

Fig.1 Schematic representation of the two TT+PCM configurations – TGU_TT+PCM(IN) and TGU_TT+PCM(OUT) – tested by means of experimental analysis on an on-purposed realized prototype; the reference technology (TGU_CG), a triple glazed unit made of clear glass panes is also shown on the left

The TT glass employed in the prototypes is a commercially available product (Solardim Eco [10]), where the switch of the optical properties takes place in the temperature range 20-40 °C. In Table 1 the optical properties of a TT layer are given – layout: 2x1mm clear glass pane and 1.7 mm resin matrix layer. It is possible to see that, for that configuration, the transmittance in the visual range is almost halved when the active layer is in on state, while the reduction of the solar transmittance and of the g-value is about 40% and 25%, respectively. The TT glass is a 9.5 mm thick laminated glass (4+4 clear glass panes) with a 1.5 mm resin layer – high doped (3.5%) for an optimum switching effect.

The Phase Change Material used in the window cavity is a commercially available product (RT35HC [11]) based on n-alkanes and waxes. It is a new generation of the same PCM employed in the previous experimental analysis on a simple PCM glazing prototype [1,5] and shows higher energy density properties, i.e. a heat storage capacity of about 245 J g⁻¹ within the temperature range 27-42 °C. The nominal melting temperature is 35 °C and the nominal phase change range is 33-37 °C. The specific heat capacity of the material outside the phase change range is approximately 2 J g⁻¹ K⁻¹ and the heat conductivity 0.2 W m⁻¹ K⁻¹.

The two materials (PCM and TT layer) were chosen for the very good match between the switching range of the TT layer and the phase change range of the PCM: when the PCM starts the phase change, its absorptance decreases and the transmittance increases [4]; at the same time, the TT layer starts to reduce its transmittance, thus lowering the amount of solar radiation that can be absorbed by the PCM layer. The more the PCM layer melts, the less is the solar irradiance transmitted by the TT layer. It is worth mentioning that, although the prototype was realized with commercially available products, which were not designed on-demand, the coupling potentials between the two advanced materials is significant. In fact, since both the technologies are based on n-alkanes mixtures, where the phase change can be freely change along almost the whole temperature scale, their performance can be tuned according to the desired range of operation. It is thus possible to imagine that optimized configurations (thickness of the PCM layer, PCM nominal temperature and coupled TT switching range) can be easily produced for different climates.

3. Methods

3.1. Experimental test rig

The TT+PCM glazing prototype and the reference TGU were tested by means of an outdoor test cell facility. The two samples were installed on the same façade (south exposed) of the thermostatic cell one above the other (the TT+PCM at the bottom, the reference TGU at the top). The internal sizes of the test cell (1.6m wide, 3.6m long and 2.5m high.) were chosen accordingly to the IEA-SHC TASK 27 specifications and correspond to the typical dimensions of façade modules used in office buildings. The walls, floor and ceiling of the test cells are made up of a sandwich panels ($U\text{-value} = 0.45 \text{ W m}^{-2} \text{ K}^{-1}$). The test cell is located on the flat roof of the Energy department so that shades from surroundings are avoided. The internal temperature of the test cell can be controlled, with a tolerance of $\pm 1 \text{ }^\circ\text{C}$, by means of a full air system – the set-point used in the summer season was 26°C . The system presents particular features so that the air from the AHU is uniformly distributed in order not to influence the response of the sensors placed on the internal facing surfaces.

The test cell facility where the measurement campaign was carried out is located in Torino, Italy ($45^\circ 04' \text{N}$; $07^\circ 42' \text{E}$) – humid sub-tropical climate, Cfa according to Köppen climate classification [12].

The measurement apparatus consisted of several different sensors connected to a data logger for continuous data acquisition. Measurements were performed with a scan rate of 15 minutes, while hourly data were later obtained as average of the readings and used for data analysis. Three types of sensors were used during the experimental campaigns: thermocouples for surface and air temperature measurements; heat flux meters for heat flux measurements; pyranometers for outdoor and transmitted solar irradiance. All the sensors were calibrated and/or verified in the laboratory before they were used for the experimental campaign. The resulting highest likely uncertainties, adopting the 95% confidence limit, were: $\pm 0.3 \text{ }^\circ\text{C}$ for temperature measurements, $\pm 5\%$ for the hourly heat flux measurements and from 2% to 5% for the hourly total radiation measurement. It is worth mentioning that the surface temperature and the heat flux exchanged at the indoor surface of the TT+PCM prototypes were monitored by more sensors (3 thermocouples and 2 heat flux meters, respectively) in order to take into account non-uniformity – a phenomenon that can easily occur in case of PCM glazing systems, as shown in a previous experiment [1,5]. On the contrary, surface temperature and heat flux of the reference TGU were monitored with just one sensor for each physical quantity – the sensors being placed at the centre of the glazing.

Temperature and heat flux sensors were shielded from direct solar radiation by means of highly reflecting thin aluminum square elements. This procedure is necessary since thermocouples and heat flux meters absorb the incident solar radiation and they thus measure much higher temperatures and heat fluxes than the actual ones. However, it is important to highlight that such a provision modifies the local physical behaviour of the system and can influence the reading of the sensors to a certain extent. This phenomenon is of particular relevance when PCM windows are under investigation since the presence of the sensor and of the shield is such that it locally interferes with the phase transition process. Unfortunately this perturbation is unavoidable in practice and the adopted procedure was meant to reduce the phenomenon to the minimum extent.

3.2. Data analysis

The data analysis was performed for “typical days”, following the same procedure developed in the previous papers [1,5]. In particular, three “typical days” were selected for each of the two configurations. The three days are characterized by different daily solar irradiation, H (kWh m^{-2}). Days with low H are cloudy and show relatively low average air temperature. Days with moderate H have daily irradiation and daily average air temperature close to the average values given by Italian national standard UNI 10349 [13]. Finally, days with high H present a daily irradiation and maximum outdoor air temperature as close as possible to those given in the above mentioned technical standard. The boundary conditions of the days selected for the analysis are summarised in Table 2 and 3.

Data analysis was carried out by comparison of the energy performance of the innovative prototypes with that of the reference conventional triple glazed unit.

Table 2 Outdoor boundary conditions of the days selected for the energy performance assessment of TGU_TT+PCM(IN)

Day type	Daily solar irradiation	Daily average outdoor air temperature	Daily maximum outdoor air temperature	Daily minimum outdoor air temperature
	kWh m ⁻²	°C	°C	°C
Low H	1.1	21.6	23.6	18.1
Moderate H	3.0	24.3	29.6	19.8
High H	3.7	27.9	33.0	21.7

Table 3 Outdoor boundary conditions of the days selected for the energy performance assessment of TGU_TT+PCM(OUT)

Day type	Daily solar irradiation	Daily average outdoor air temperature	Daily maximum outdoor air temperature	Daily minimum outdoor air temperature
	kWh m ⁻²	°C	°C	°C
Low H	1.4	19.4	22.3	16.9
Moderate H	2.9	23.5	29.1	19.0
High H	3.7	27.6	33.2	22.2

3.3. Performance parameters

The evaluation of the energy performance of advanced building components, such as PCM glazing systems, can be difficultly carried out by means of well-established metrics – e.g. *U-value*, *g-value*. This is due to the fact that traditional performance parameters have been developed for static systems under steady state conditions. While the application of these metrics to a conventional building component, though with some simplification and inaccuracy, is able to provide enough information about the performance of the system, the adoption of well-established metrics to dynamic and responsive technologies is often meaningless or highly inaccurate.

For this reason, the performance analysis was carried out, by comparison between the innovative concept and the reference technology, considering the following quantities:

- hourly profile (over 24 hours, from 08:00 to 08:00 of the following day) of the so-called specific “surface” heat flux [W m⁻²] – i.e. the heat flux, exchanged by convection and long-wave radiation, between the indoor surface of the glazing and the indoor environment;
- hourly profile (over 24 hours, from 08:00 to 08:00 of the following day) of the specific “total” heat flux [W m⁻²] – i.e. the sum of the specific “surface” heat flux and of the specific transmitted solar irradiance;
- net specific energy [Wh m⁻²], that crosses the glazing during the entire day – i.e. the integral of the specific “total” heat flux over 24 hours, from 08:00 to 08:00 of the following day.

An attempt was also made to characterize the *U-value* of the TT+PCM glazing concepts. In order to exclude the influence of solar irradiance, only night-time readings were used for the calculation of this parameter. Due to practical reasons, it was not possible to evaluate this metric when the PCM layer was completely in liquid state – boundary conditions were never so that it could be possible to monitor the PCM layer in complete liquid state after the sunset. Moreover, the evaluation of the *U-value* when the PCM is in transition phase is meaningless – the glazing is far from being in steady state and thus the significance of this parameter is jeopardized.

Therefore, the thermal transmittance was only assessed when the whole PCM layer was in solid state. In order to reduce the effect of the transient state on the *U-value*, only days with low *H* ($H < 1$ kWh m⁻²) were used for this analysis – the PCM layer is almost always outside the phase change range under these conditions and thus the TGU_TT+PCM presented a more linear behaviour that can be better approximated by the thermal transmittance.

The assessment of the *U-value* was carried out by linear correlation (OLS method) between the specific “surface” heat flux and the thermal gradient between the outdoor and in the indoor air temperature. In total, 160 couples of heat flux and thermal gradient, evenly distributed over 6 months, were used. Since the thermal transmittance does not depend on the position of the layers, just one value was assessed for the two configurations TGU_TT+PCM(IN)

and TGU_TT+PCM(OUT). The U-value of TGU_CG was also calculated with the same method, for reference purpose.

4. Results and discussion

The assessment of the U-value of the TT+PCM systems and the reference TGU shows that the insertion of the PCM does not sensibly increase the heat transmittance of the glazing components. In fact, a thermal transmittance of $0.80 \text{ W m}^{-2} \text{ K}^{-1}$ was found for both the glazing systems. A slightly different coefficient of determination R^2 was found for the two linear regression analyses – i.e. 0.86 and 0.93, for TGU_TT+PCM(IN)/(OUT) and TGU_CG, respectively. This means that a better correlation is found for the reference technology than for the innovative glazing – a phenomenon that can be explained considering the lower heat capacity of the conventional fenestration. However, the relatively high value of the coefficient of determination in the case of the TGU_TT+PCM(IN)/(OUT) shows that a good accuracy is achieved in this correlation too, and that the obtained value of heat transmittance is robust and reliable. Nevertheless, it is important to highlight that such a value is only representative of the behaviour of the system when the PCM is in solid state, but not of the complete dynamic of the prototype, whose appearance and performance can significantly change according to the state of aggregation of the PCM – e.g. in Fig. 2 the dynamic of the melting/re-solidification of the PCM layer is shown, for the TGU_TT+PCM(OUT) configuration.

The role of the increased thermal inertia in the TGU_TT+PCM is clearly shown in Fig. 3, where the time profile of the specific “surface” heat flux of the TGU_TT+PCM(IN) (Fig. 3 a) and of the TGU_TT+PCM(OUT) (Fig. 3 b) is plotted, for different “typical days” against that of the reference technology. It is possible to notice that, compared to the conventional TGU, both the advanced concepts are capable of smoothing and (to a certain extent) shifting the peak of the heat flux exchanged by radiation (in the long-wave range) and convection. This phenomenon is due to the increased heat capacity of the fenestration. The highest reduction is seen in case of high H days, when the exchanged heat flux is reduced to about one third of that of the TGU.

The energy accumulated within the PCM layer is released later during the evening – “discharge phase” of the PCM layer. This behaviour can be clearly detected by looking at the time profile of the specific “surface” heat flux from approximately 18:00 onwards. At that time, the heat flux exchanged in case of the reference technology falls very quickly as soon as the solar irradiation gets low and the façade is no longer exposed to direct solar irradiation. On the contrary the specific surface heat flux exchanged by TGU_TT+PCM(IN)/(OUT) is always greater. The phenomenon is of particular relevance when the day is sunny (moderate and high H), i.e. when the PCM layer is activated by solar irradiation, while it is almost negligible during cloudy days (low H).

The time profiles of the specific total heat flux that is exchanged by the glazing systems are given in Fig. 4 (a: TGU_TT+PCM(IN); b: TGU_TT+PCM(OUT)). In these charts it is possible to see the different behaviours of the two TT+PCM concepts when there is very high solar irradiation (high H): while the configuration with the PCM in the innermost cavity is always able to reduce the total heat flux, regardless the boundary conditions, down to a maximum value of 35 W m^{-2} (reference technology: almost 250 W m^{-2}), the other configuration (TGU_TT+PCM(OUT)) is only able to reduce the total heat flux down to a maximum value of approximately 70 W m^{-2} (reference technology: almost 250 W m^{-2}). This is due to the different state of the PCM layer: while in the first case the phase change is not completed, in the second case, due to the position of the PCM layer (in the outermost cavity), the whole PCM layer melts and the latent heat of fusion is completely exploited (Fig. 2).

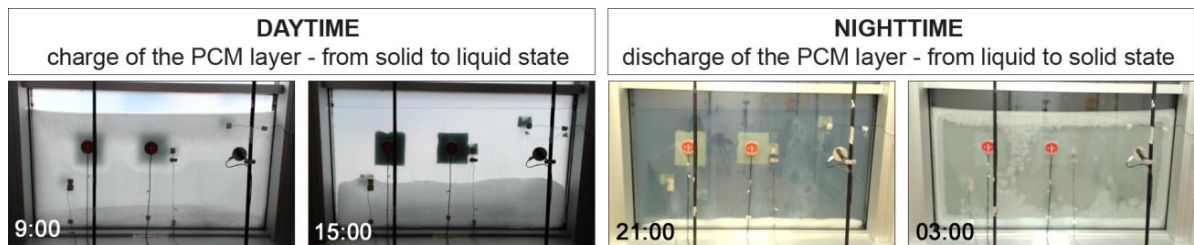

Fig.2 Visual aspect of TGU_TT+PCM(OUT) during different times of the day, in case of a summer day with moderate or high H

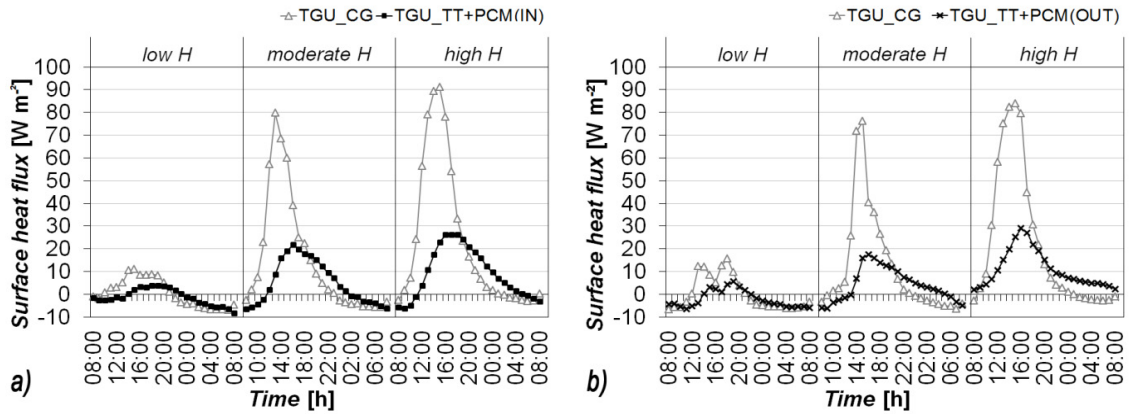

Fig.3 Time profiles of the specific “surface” heat flux – a): TGU_TT+PCM(IN) and reference; b): TGU_TT+PCM(OUT) and reference

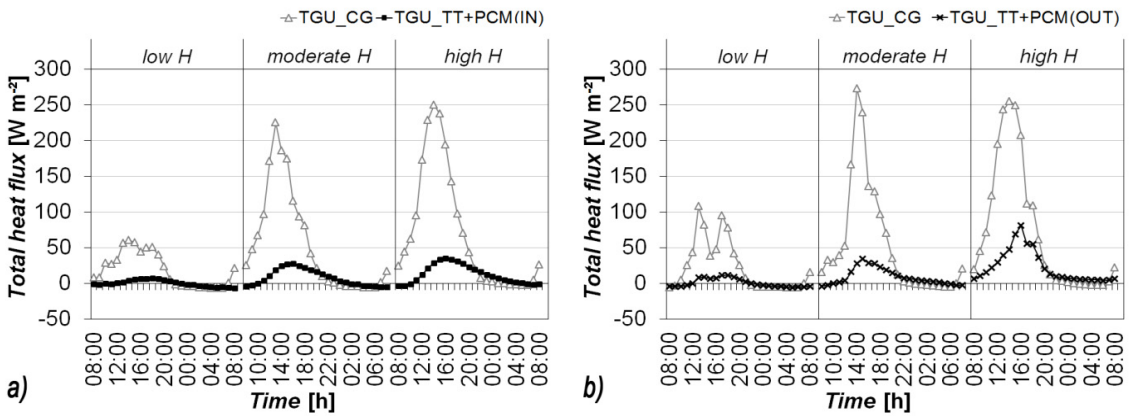

Fig.4 Time profiles of the specific “total” heat flux – a): TGU_TT+PCM(IN) and reference; b): TGU_TT+PCM(OUT) and reference

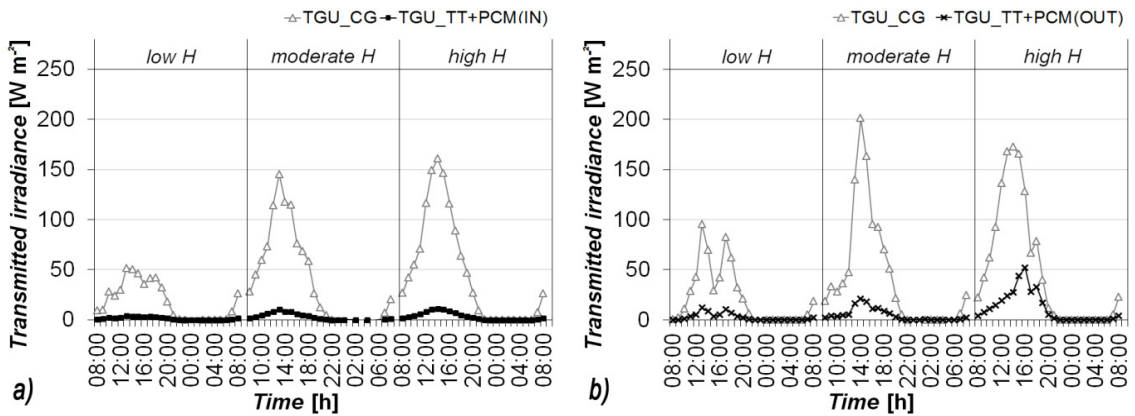

Fig.5 Time profiles of the transmitted irradiance – a): TGU_TT+PCM(IN) and reference; b): TGU_TT+PCM(OUT) and reference

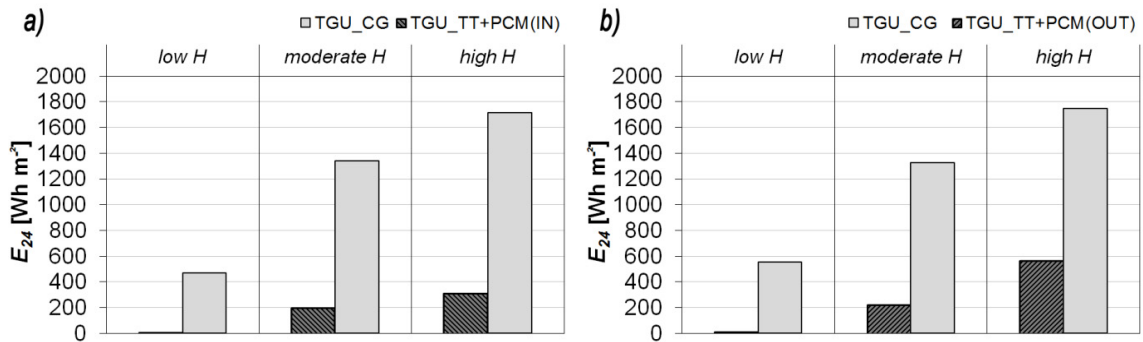

Fig.6 Daily transmitted energy E_{24} – a): TGU_TT+PCM(IN) and reference; b): TGU_TT+PCM(OUT) and reference

The state of aggregation of the PCM layer determines the optical properties of the advanced glazing: in particular, when it is in liquid state, the solar and visual transmittance are sensibly higher than when in solid state [4]. This particular feature is highlighted by the time profile of the transmitted irradiance (Fig. 5), i.e. the radiative energy flux in the short-wave region (250-2500 nm) that enters the indoor environment through the glazing. In days characterized by high solar irradiation (high H), the transmitted irradiance is always very low (maximum value $\sim 12 \text{ W m}^{-2}$) if the TGU_TT+PCM(IN) is employed. On the contrary, if the TGU_TT+PCM(OUT) is adopted, a much higher transmitted irradiance is recorded (up to a maximum value of $50 \text{ W m}^{-2} \text{ K}^{-1}$). Although this configuration is still able to reduce to a great extent the direct solar gain if compared to the reference fenestration, it shows a worse performance than that of the TGU_TT+PCM(IN).

The effect of the increased transmitted irradiance on the energy performance becomes clear when the specific daily net specific energy E_{24} is assessed (Fig. 6). If compared to the reference technology (TGU_CG), the configuration with the PCM in the innermost cavity – TGU_TT+PCM(IN) – is able to reduce E_{24} by 99%, 85% and 82%, for days with low H, moderate H and high H, respectively. The configuration with the PCM in the outermost cavity – TGU_TT+PCM(OUT) – shows a very similar performance in case of low H and moderate H (-97% and -83%, respectively), but when the day is characterized by high irradiation (high H) – and high outdoor air temperature – the reduction in E_{24} is just 68%. A direct comparison between the two configurations shows that the net specific energy in case of TGU_TT+PCM(IN) is half of that in case of TGU_TT+PCM(OUT). Such a comparison is possible because the E_{24} values measured for the reference technology in the two days with high H are very similar (1716 and 1748 W m^{-2}) although data were taken during two different campaigns.

Although the performance of TGU_TT+PCM(OUT) is still appreciable and considerably better than that of the reference glazing, it is possible to highlight that this configuration is not completely able to control the “charge” phase of the paraffin and to prevent the complete melting of the PCM. This behaviour can be explained considering that when the PCM is located in the outermost cavity the following phenomena take place:

- the amount of solar irradiation that impinges on the PCM layer is higher than the one that impinges on the same layer when it is located in innermost cavity;
- the PCM layer is closer to the outdoor environment, which shows an higher energy content than the indoor environment – the outdoor air temperature is higher than the indoor air temperature for most of the time – and thus it naturally shows a higher energy content than when the same layer is positioned in the innermost cavity;
- the heat transmission towards the inner layers of the glazing is reduced by the argon-filled, low-e coated cavity.

The different position of the PCM layer thus affects the thermo-physical behaviour of the system and makes one configuration more efficient than the other – at least as far as the summer season is concerned, and especially in case of high solar irradiation.

5. Conclusion

The experimental investigation of an innovative glazing concept, where phase change materials are coupled with a thermotropic layer, demonstrates the very good performance of this system during the summer season, in a humid sub-tropical climate.

Two configurations of such a technology were tested and, although they are both able to reduce to a great extent the solar energy gain if compared to a conventional Triple Glazed Unit (in the range -99÷68%), the configuration with the PCM placed in the innermost cavity of the glazed unit shows an even better performance. This system is always able, regardless the outdoor boundary conditions – and in particular of the amount of solar irradiation – to prevent the complete melting of the PCM layer, with a positive effect on the behaviour of the fenestration.

On the contrary, the configuration that presents the PCM in the outermost cavity shows a complete exploitation of the latent heat of fusion of the PCM, which melts completely. Under these circumstances, the irradiance transmitted through the TT+PCM glazing is increased (the solar and visual transmittance when the PCM is in liquid state is higher than that when the PCM layer remains in solid or mushy state), resulting in a less efficient energy performance of the system.

It is worth mentioning that the temperature range in which the PCM performs the change of state was chosen starting from the experience gained during a previous activities[1,3], on glazing systems without TT layers. A different transition temperature of the PCM layer would have probably resulted in another response and different performance. In particular, it is possible to hypothesize that the TT+PCM(IN) configuration could host a PCM with a lower nominal melting temperature – but still high enough to prevent that the PCM layer gets completely melted – while a PCM with a higher nominal melting temperature would be necessary in the TT+PCM(OUT) configuration.

Further investigation will be conducted to assess the winter performance and to verify the durability of the proposed prototype.

Acknowledgements

This research is part of the activities carried out in the “SMARTglass” framework, a project funded by the Regione Piemonte in 2010. This article has been written within the Research Centre on Zero Emission Buildings (ZEB). The authors gratefully acknowledge the support from the ZEB partners and the Research Council of Norway.

References

- [1] Goia F, Perino M, Serra V, Zanghirella F. Experimental assessment of the thermal behaviour of a PCM glazing. Proceedings of IAQVEC 2010 - The 7th International Conference on Indoor Air Quality, Ventilation and Energy Conservation in Buildings, Syracuse, New York (USA): 2010, p. 1–8.
- [2] Goia F, Perino M, Haase M. A numerical model to evaluate the thermal behaviour of PCM glazing system configurations. Energy and Buildings 2012;54:141–53.
- [3] Goia F. Thermo-physical behaviour and energy performance assessment of PCM glazing system configurations: A numerical analysis. Frontiers of Architectural Research 2012;1:341–7.
- [4] Goia F, Zinzi M, Carnielo E, Serra V. Characterization of the optical properties of a PCM glazing system. Energy Procedia 2012;30:428–37.
- [5] Goia F, Perino M, Serra V. Improving thermal comfort conditions by means of PCM glazing systems. Energy and Buildings 2013;60:442–52.
- [6] Manz H, Eglolf PW, Suter P, Goetzberger A, Abel E. TIM – PCM external wall system for solar space heating and daylighting. Solar Energy 1997;61:369–79.
- [7] Weinläder H, Beck A, Fricke J. PCM-facade-panel for daylighting and room heating. Solar Energy 2005;78:177–86.
- [8] GLASSX - www.glassx.ch.
- [9] Muchling O, Seeboth A, Haeusler T, Ruhmann R, Potechius E, Vetter R. Variable solar control using thermotropic core/shell particles. Solar Energy Materials and Solar Cells 2009;93:1510–7.
- [10] Tilse Industrie- und Schiffstechnik GmbH - www.thilse.com.
- [11] RUBITHERM GmbH - www.rubitherm.com.
- [12] Peel MC, Finlayson BL, McMahon TA. Updated world map of the Köppen-Geiger climate classification. Hydrology and Earth System Sciences 2007;11:1633–44.
- [13] UNI. Riscaldamento e raffrescamento degli edifici - Dati climatici (in Italian) [Heating and cooling of building - Climatic data] (UNI 10349:1994) 1994:35.