

Recent progress of the rulemaking on grid-connected photovoltaic generation

*Original*

Recent progress of the rulemaking on grid-connected photovoltaic generation / V., Barbu; Chicco, Gianfranco; Corona, Fabio; Spertino, Filippo. - In: THE SCIENTIFIC BULLETIN OF ELECTRICAL ENGINEERING FACULTY. - ISSN 1843-6188. - STAMPA. - Year 12:No. 2 (19)(2012), pp. 5-11.

*Availability:*

This version is available at: 11583/2538719 since:

*Publisher:*

Bibliotheca Publishing House, Targoviste, Romania

*Published*

DOI:

*Terms of use:*

This article is made available under terms and conditions as specified in the corresponding bibliographic description in the repository

*Publisher copyright*

(Article begins on next page)



Valahia University of Targoviste  
Faculty of Electrical Engineering

# THE SCIENTIFIC BULLETIN of ELECTRICAL ENGINEERING FACULTY

International Publication  
of Advanced Studies  
in Electrical Engineering

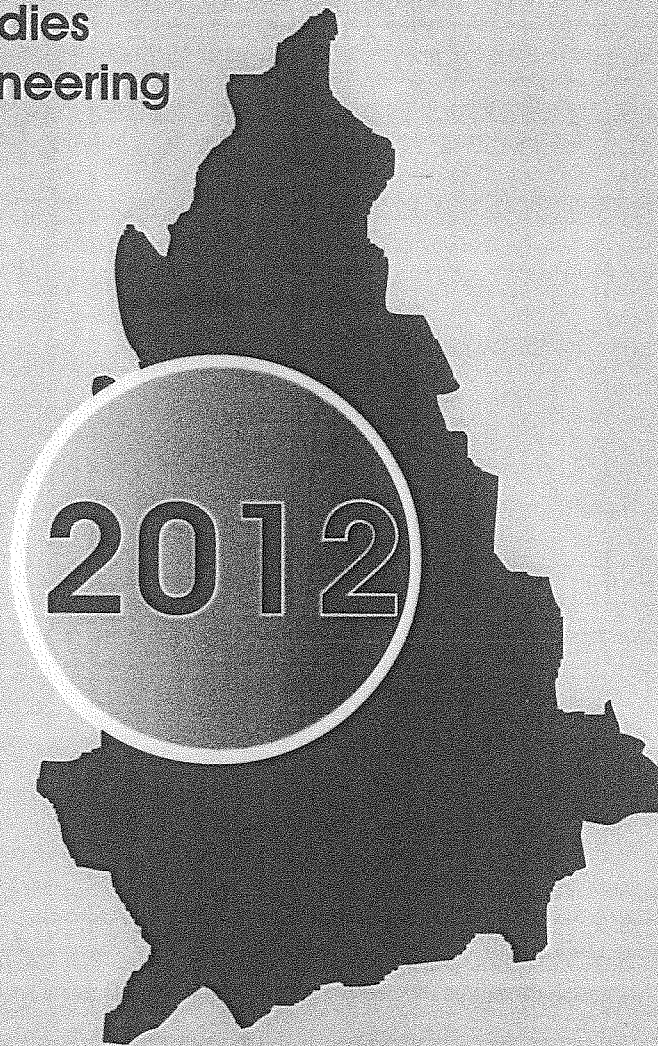

Year 12  
No. 2 (19)

[www.buletinfie.ro](http://www.buletinfie.ro)

## RECENT PROGRESS OF THE RULEMAKING ON GRID-CONNECTED PHOTOVOLTAIC GENERATION

V. BARBU<sup>1</sup>, G. CHICCO<sup>2</sup>, F. CORONA<sup>2</sup>, F. SPERTINO<sup>2</sup>

<sup>1</sup>Universitatea Politehnica din București, Facultatea Energetica, Splaiul Independenței 313, București, Romania

<sup>2</sup>Politecnico di Torino, Energy Department, Corso Duca degli Abruzzi 24, 10129 Torino, Italy

E-mail: barbuvalentina@yahoo.com, gianfranco.chicco@polito.it, fabio.corona@polito.it, filippo.spertino@polito.it

**Abstract.** *The rationale for the connection of distributed generators to the grid in case of abnormal events has been recently changed, passing from the obligation to switch the local generation off to the requirement of keeping it on within a certain range of frequency and voltage variations with respect to the rated values. This paper summarizes the concepts according to which the new requirements have been set up, with particular reference to the photovoltaic (PV) systems connected to Medium Voltage and Low Voltage systems, and overviews the recent upgrades of the Italian rulemaking process. A real case example showing the voltage and current waveforms during the disconnection of the PV generation within a power plant is presented.*

**Keywords:** photovoltaic systems, grid connection, ride-through capability, rulemaking.

### 1. INTRODUCTION

The process of restructuring the electricity business in Europe, started more than two decades ago, has involved numerous aspects on the technical and economic points of view [1]. One of these aspects has been the extension of the right to connect local resources to the electrical grid from a small set of entities (the authorized self-producers) to a larger set of entities owning the local production plants. In the new situation, the electricity distributors have found a number of new sources connected to the grid, and the issue of guaranteeing the quality and continuity of the electricity supply in the new network structure has been immediately considered as a main priority. The distributors have first elaborated their own technical rules for the connection of the local resources to their grids. Among these rules, a key point was the obligation to disconnect from the network the local systems containing distributed generation as fast as possible when the RMS voltage was falling outside the normal operational range. For instance, the IEEE Standard 1547 (July 2003) [2] has been one of the first standards concerning distributed resource interconnection to electrical distribution systems, applied to distributed resource technologies with aggregate capacity of 10 MVA or less at the Point of Common Coupling (PCC). The IEEE Standard 1547 stated that for an RMS voltage lower than 50% of the rated voltage the distributed resource shall cease to energize the power system within 160 ms, and for an RMS voltage in the range from 50% to 88% of the rated voltage the distributed resource shall cease to energise the power system within 2 s. Similar conditions were applied for

voltages higher than the rated voltage (i.e., system de-energised within 1 s for per cent RMS voltage higher than 110% and within 160 ms for RMS voltage higher than 120%). Concerning the mode for de-energising the power system, for a peak capacity of the distributed resource not higher than 30 kW the voltage set point could be fixed or field-adjustable, while for higher peak capacity the voltage set point had to be field-adjustable.

Until a relatively low total amount of distributed generation was connected to the grid, the effect of disconnecting all the distributed resources was practically not disturbing the quality of supply in a significant way.

The diffusion of distributed generation in the distribution networks has then proceeded with the grid integration of a progressively higher number of local plants scattered in the networks. In normal conditions, the presence of some local plants equipped with controlled interfaces, aimed at maintaining the power factor close to unity and at reducing the harmonic distortion of the injected currents, has been beneficial for the distribution system operation [3]. However, in the presence of a significant amount of distributed generation, after a fault occurs the switch-off of the whole local generation would be seen by the distribution network as a steep variation in the generation power at constant load. This variation could impact on the stability of the overall system, even at the transmission system level, as the combined effect of the lack of production would be detected also at the transmission network nodes.

The need for maintaining network stability and security within acceptable ranges has pushed the transmission system operators (TSOs) towards issuing a set of recommendations. In particular, on 18 June 2011 the European Network of the Transmission System Operators (ENTSO-E) has remarked that an increase of local generation could lead to a critical situation for national system security, as the simultaneous disconnection of a large number of local plants could cause a significant discontinuity in the electricity production. Hence, the ENTSO-E has emphasised the need for modifying the national standards [4]–[7], also by issuing national plans for re-programming or retrofitting the existing plants.

This paper addresses the grid connection of photovoltaic (PV) plants, with the focus on discussing the characteristics and requirements for keeping the PV plant connected to the grid in normal and in some abnormal conditions. The paper reviews the recent evolution of the national standards for grid connection of the PV plants in

Italy, highlighting the provisions introduced in the national regulations to avoid the plant disconnection in case of network disturbances ranging within a feasible region of frequency and voltage variation.

## 2. RECENT EVOLUTION OF THE ITALIAN RULES ON GRID CONNECTED LOCAL PLANTS

In Italy, there are various rulemakers involved in the process of setting and updating the national standards and codes. The regulatory authority in Italy is the Authority for Electrical Energy and Gas (AEEG [8]). The national TSO (Terna) elaborated the grid code [9] in force since 1 November 2005. The grid code is composed of a main text and a number of annexes. The standards on electrical components and plants are issued by the Italian Electrotechnical Committee (Comitato Elettrotecnico Italiano, CEI). The CEI has made a specific rulemaking concerning the connection of local generation resources to the grid. The starting point has been the Standard CEI 11-20, already active before the restructuring of the electricity business as a standard containing rules for self-producers, with successive updates referring to the backup generation to supply the load in emergency conditions. The Standard CEI 11-20 introduced the conceptual partitioning of the local portion of the electrical system into three sections, separated through protection devices defined by a set of functions these devices must provide (Figure 1):

- the local generation section, interfaced with the system through the *generator protection* device;
- the portion of the local network enabled to remain connected to the local generator (in islanding operation) if a fault in the external distribution network occurs; this network is interfaced with the system through the *interface protection* device;
- the portion of the local network that can be lost if a fault in the external distribution network occurs; this network is interfaced with the system through the *general protection* device.

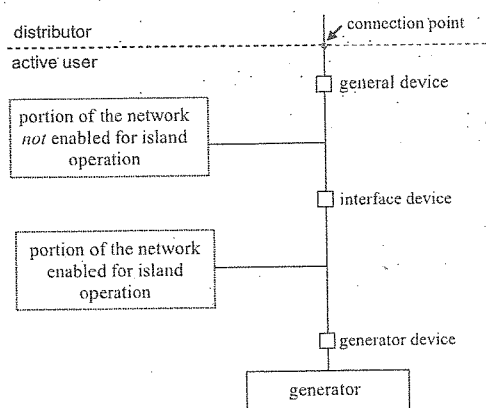

Figure 1: Definition of the plant sections associated to the general, interface and generation protection devices.

Concerning the grid connection of local resources, in Italy the first rules appeared in the form of Directives issued by ENEL as the largest private electricity

distribution company. These rules were based on setting up the requirements a local system had to meet in order to enable its connection to the grid. These rules then evolved by extending the discussions at the CEI level, resulting in issuing the CEI Standard 0-16 [10] (February 2008) referring to the connections to High Voltage (HV) and Medium Voltage (MV) systems. On March 30, 2008 the AEEG issued the Deliberation ARG/elt 33/08 [11]. The second edition of the Standard CEI 0-16 was then updated and issued with the date of July 2008. After a few years, this document is currently under revision by CEI.

In December 2011, the CEI issued the Standard CEI 0-21 referring to the connections to Low Voltage (LV) systems [12], to complete the coverage of the distribution systems by including the LV systems.

On March 2012, Terna and AEEG issued a set of documents in response to the ENTSO-E recommendations. The AEEG Deliberation 84/2012/R/EEL [13] appeared on 8 March 2012 defines the scheduling and the actuation rules of the Annexes to the grid code and of the Standards CEI 0-16 and CEI 0-21 referring to Low Voltage systems. This deliberation refers to the electricity production plants connected to the MV network with power higher than 50 kW in operation at March 31, 2012, and the electricity production plants that will be connected to the MV and LV grids after April 1, 2012. On 13 March 2012, in actuation of the AEEG Deliberation 84/2012/r/eel, three new annexes to the grid code were published, that is, the Annex A68 (photovoltaic production plants – Minimal requirements for the connection and the operation in parallel with the High Voltage grid), A69 (Connection criteria of the production plants to the defence system of Terna) and A70 (Technical rules of the system requirements for distributed generation). In particular, the Annex A70 [14] indicates the ranges of operation of the grid-connected production plants, stating that “all the plants and the related machinery and devices have to be designed, constructed and operated in order to remain in parallel [with the grid] also in conditions of emergency and network restoration”. On 1 July 2012, the CEI issued the second edition of the Standard CEI 0-21 [12], incorporating the changes required in the latest regulatory documents.

The present evolution is moving towards establishing plans for setting up pre-scheduled services, in order to reduce the effects of uncertainty in the electricity provision from non-programmable local generation sources. For this purpose, on August 2012 two new annexes to the grid code were issued, namely, Annex 71 (Application rules for settlement in case of modification of the distribution network property) and A72 (Procedure for the reduction of distributed generation in emergency conditions of the National Electrical System) [15], continuing the process of upgrading the networks. The Annex 72 has introduced the concept of Reducible Distributed Generation (RDG), associated to generation plants having all the following characteristics: plants of at least 100 kW size, connected to the MV network, supplied by non-programmable wind or photovoltaic sources, that inject in the grid their entire production (net of the auxiliary services). RDG is partitioned into remote controlled (RDG connected with dedicated lines, that can be switched off by the distributor upon specific requirement by Terna) and switchable with

pre-notification (RDG connected with non-dedicated lines in which there are also customer plants, that can be switched off by the plant owner). For the remote-controlled RDG the control centre of Terna communicates to the Distributor the need of cutting the RDG off, indicating the dedicated lines to be switched off and the corresponding time interval for the reduction. For the switchable RDG, seven days before the target day Terna communicates the need of cutting off the production from RDG, indicating the list of the groups to be cut, the day and hour, and the severity level (order of the groups to be cut off). The communication is valid if it is not withdrawn up to two days before the target date. The Distributor informs the RDG owner, that must switch off its production as required (avoiding to incur in penalties).

### 3. TECHNICAL ISSUES OF THE GRID CONNECTION

#### 3.1 Types of users

Concerning the recent CEI definitions, the users have been partitioned into two main categories. The *active* users (above 1 kW) are connected to the grid (in continuous mode, or for a short duration, or in island operation) to produce energy and may contain any (static or rotating) machine that operates the conversion from a given form of useful energy into electricity. The *passive* users are the users connected to the Low Voltage network that do not fall into the previous definition of active users. Examples of passive users are battery charge stations for electric vehicles, public lighting systems, and other temporary plants, for instance for civil works or exhibitions.

#### 3.2 Frequency issues

Frequency is the network parameter subject to the stricter limitations in its variation around the rated value (50 Hz). The main issues referring to frequency deal with the behaviour of the energy production plants during the frequency transients, the reconnection and active power control in function of the frequency, and the start-up and gradual increase of the power injected in the grid.

In the foreword to the AEEG Deliberation 84/2012/R/EEL, it is indicated that for the photovoltaic plants the existing connection standards required their instantaneous disconnection from the grid for frequency variations above 0.2-0.3 Hz, and it is stated that the interface protection systems and the inverters have to become less sensitive to the frequency variation, in order to remain connected to the grid also for frequency variations between 47.5 Hz and 51.5 Hz.

The technical regulation admits restricted thresholds and permissive ones both for voltage and frequency (Figure 2), in order to taking into account the system and the local disturbances. In case of system disturbance a large section of the grid is affected and the frequency could change very slowly, while the phase voltages conserve a symmetrical behaviour, therefore only the permissive thresholds are activated. While in case of local phenomena, such as faults or a relay opening, the DSO or a local device should enable the restricted thresholds to promote the system disconnection from the network. In

particular, the new requirements ask for detecting a local phase-to-ground, or phase-to-phase or three-phase fault measuring the positive- ( $V^+$ ), negative- ( $V^-$ ) and zero-sequence ( $V^0$ ) voltage components, computed through the decomposition of the steady-state voltage phasors of the three-phase system (the method of symmetrical components [16]), and comparing them with a threshold set.

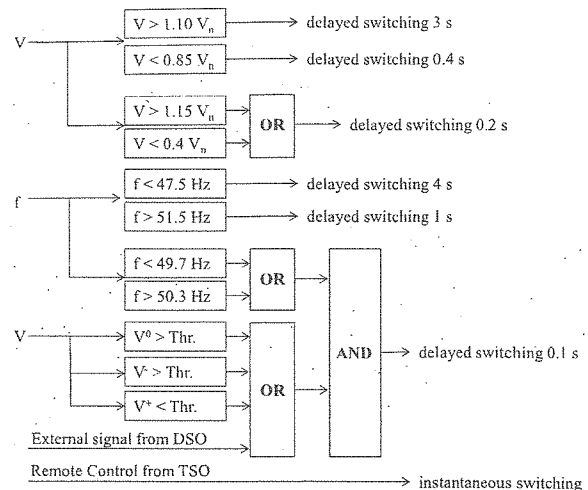

Figure 2: Control logic of the local interface protection system for MV systems.

#### 3.3 Voltage issues

In order to avoid voltage problems, the generation plants have to remain permanently connected to the Medium Voltage and Low Voltage networks, in any loading condition, when the voltage in the connection point falls within the interval from 85% to 110% of the rated voltage  $V_n$  (normal operation range). The active user shall guarantee that these operating intervals are respected by both the interface protection and the production plant controls. Active and reactive power have to be restored within 200 ms after the generator reaches the normal operation range. The distributor verifies that these requirements are fulfilled.

At the start-up the voltage interval is a little bit different and it goes from 90% to 110% of the rated voltage. The connection of the generator to the MV grid is allowed after a minimum time period of 300 seconds, in which the voltage must remain within the specified range, if the active user is disconnected for interface protection device's intervention, otherwise the minimum time period is reduced to 30 seconds.

In order to avoid losing the distributed resources due to faults in the network that cause voltage reductions in some areas, the generation plant shall remain connected to the network according to a predefined voltage-duration curve representing the Under Voltage Fault Ride Through (UVFRT) capability, as illustrated in Figure 3 for the LV grid and in Figure 4 for the MV grid. In Figure 4, over the UVFRT curve it is represented the Over Voltage Fault Ride Through (OVFRT) one, which describes the static generator behaviour in case of over-voltage, such as when the faults in the network are cleared and switched are closed.

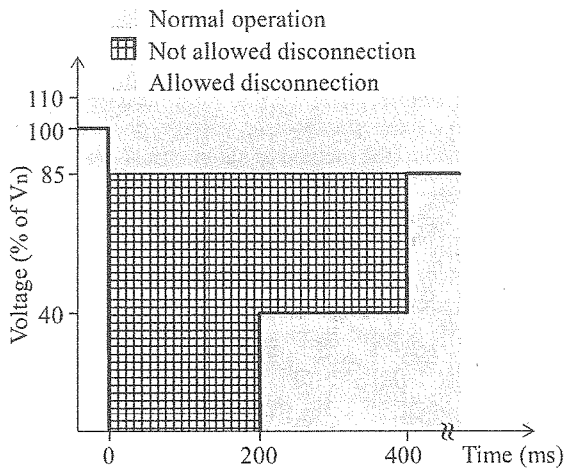

Figure 3: Under Voltage Fault Ride Through (UVFRT) capability for LV grid-connected static generators.

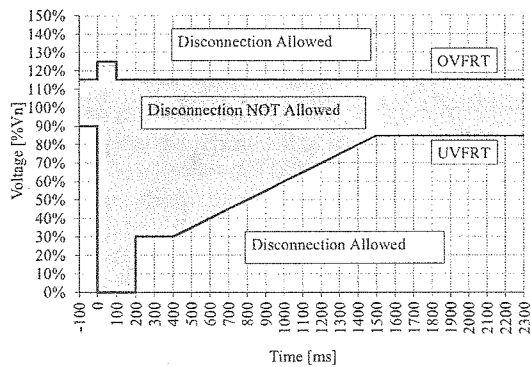

Figure 4: UVFRT and OVFRT capabilities for MV grid-connected static generators.

3.4 Reactive power capability

The capability curves of the generators are defined with reference to the apparent rated power  $S_n$ . The new technical rules for the MV (and HV) grid connection of static converters fix the requested capability of reactive power generation depending on the maximum active power in normal operating condition (rated voltage and unitary power factor):

- for rated power lower than 400 kW the reactive power capability is limited as shown in Figure 5, with power factor constrained between 0.9 inductive and 0.9 capacitive.
- for rated power equal or higher than 400 kW the reactive power capability limits are semi-circular, as shown in Figure 6.

The recent technical rules state that the distributed generators should participate at the grid voltage control. Obviously, when the voltage at common coupling point is higher than the rated value, the electronic converter must absorb inductive power, while when it is lower the converter must generate capacitive power.

In particular, the static converters have to provide an automatic (locally controlled) reactive power absorption according to the curve in Figure 7, where  $P_n$  is the active power rating. This kind of control is activated when the

voltage exceeds the lock-in value, defined by the grid operator in the interval  $V_n \div 1.1V_n$  (1.05  $V_n$  by default). As soon as the active power decreases under  $0.5 P_n$  or the voltage reaches the lock-out value ( $0.9 V_n \div V_n$ , with  $V_n$  by default), the control is deactivated.

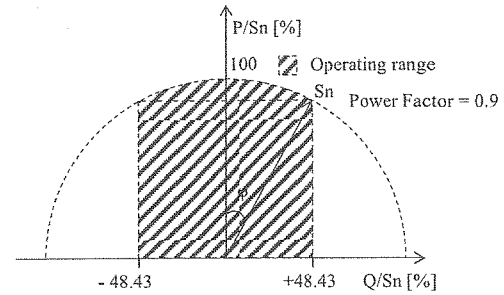

Figure 5: Reactive power capability ( $S_n < 400$  kW).

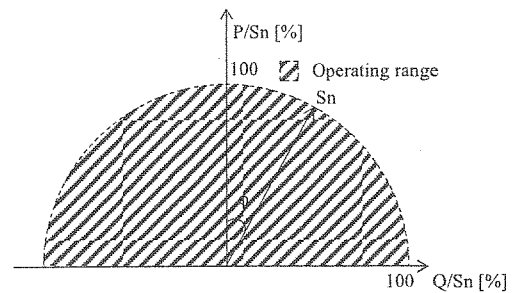

Figure 6: Reactive power capability ( $S_n \geq 400$  kW).

Moreover, all the generators with reactive power capability like the one in Figure 5 must absorb or generate reactive power according to the local control described in Figure 8, which is a function of the voltage value in the common coupling point. This can be considered an ancillary service provided by the active user to the grid operator, so it has to be requested by the DSO when the operating rules are defined. At present, some regulations issued by the AEEG are expected for the activation of such a service. By denoting the rated active power with  $P_n$ , the control parameters are the lock-in active power of  $0.2 P_n$  default value, and the voltage  $V_{1s}$ ,  $V_{2s}$ ,  $V_{1i}$  and  $V_{2i}$  set-points, which should be fixed within the  $0.9 \div 1.1 V_n$  range, with a  $0.01 V_n$  resolution.

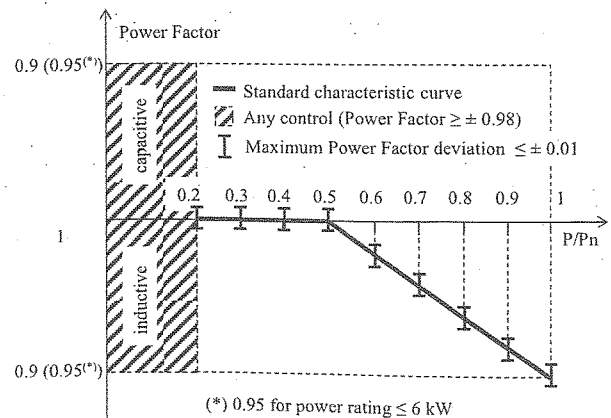

Figure 7: Reactive power control with power factor represented in function of  $P/P_n$ .

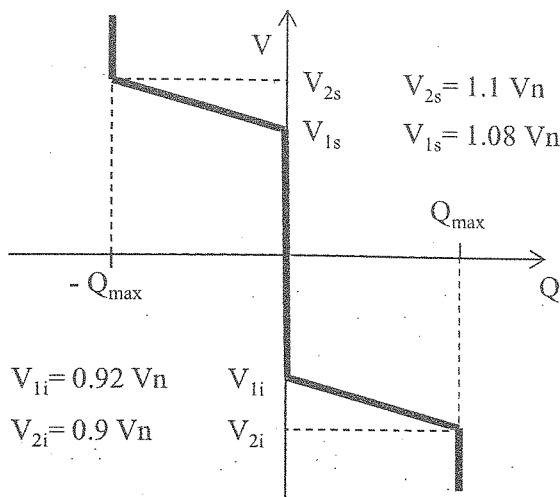

Figure 8: Reactive power control according to  $Q = f(V)$ .

### 3.5 Active power control

In order to avoid disconnection of the distributed generator from the network when the voltage at the point of common coupling increases above the  $1.1V_n$  threshold, a local control shall limit the active power. This limitation is also activated in case of over-frequency, when it overcomes the 50.3 Hz value, according to the curve in Figure 9, with frequency variation of 1.2 Hz (2.4% with respect to 50 Hz) for 100% active power variation. The static generator should decrease the output active power of an amount dependent on the over-frequency and the slope of the control curve, within a 2 seconds time period. After the over-frequency transient, when the value comes back to  $50 \pm 0.1$  Hz for at least 300 seconds, the generator can increase the power output gradually, with a fixed gradient, avoiding abrupt steps.

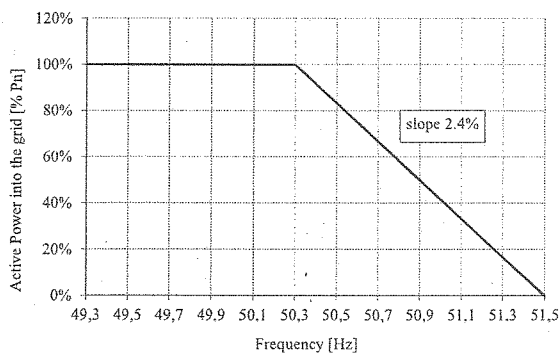

Figure 9: Active power control in case of over-frequency.

## 4 EXPERIMENTAL RESULTS FOR A GRID CONNECTED PHOTOVOLTAIC SYSTEM

Power Quality (PQ) measurements and analysis were performed on a PV plant connected to the MV grid. The system is installed on the top of an industrial building, with partially integrated poly-crystalline silicon modules, and is subject to some shading over one of the sub-fields. The total rated power is  $P_n=834.5$  kW, which accounts

for the nominal power of two different sections of 778.61 kW and 55.89 kW, respectively. All the PV arrays are connected on the LV side through 8 inverters, 6 for the first section and 2 for the second one. The network analyser was positioned at the inverters' common coupling output point.

### 4.1 Instrumentation for measurement

The measurements have been carried out by using the network analyzer HIOKI PW3198, during one week in July 2012. The instrument has eight input channels (four for voltages, and four for currents through insulated clamp sensors providing a voltage signal, with 0.5 V output at rated current input and rate of 0.1, 1, 10 or 100 mV/A) and provides a simultaneous digital sampling of voltage and current. The sampling frequency is 200 kHz for measurement of RMS voltage and current, active power and other power values, whereas for harmonic and inter-harmonic analysis the analyzer operates with 4096 points, 10 cycles (at 50 Hz) or 4096 points, 80 cycles (at 400 Hz). In normal conditions (with 16 bits of A/D converter resolution) the maximum voltage is 600 V, and in transient conditions (with A/D converter resolution 12 bits) the maximum peak voltage is 6 kV. The network analyzer allows to study events during which the given parameter thresholds are not respected.

### 4.2 Discussion of an event

An example of an event categorized as a voltage dip is illustrated in Figure 10. The left-hand side of the screen shot reports the events list, while in the centre of the picture, on the upper part the long-term evolution of a selected quantity in the time domain is shown (e.g. minimum, maximum and average value of selected phase voltage), and on the lower one the voltage and current waveforms in the selected operating point or transient event are illustrated.

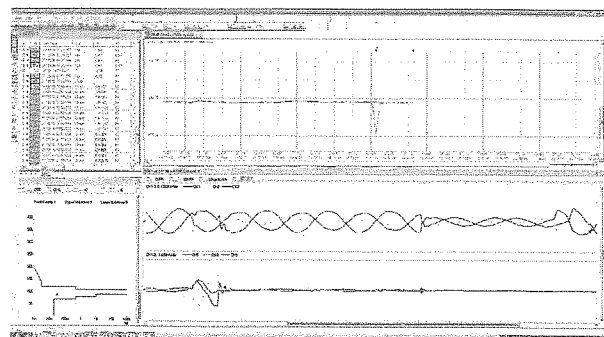

Figure 10: Screen shot of network analyzer software (voltage dip event).

For deeper analysis, Figure 11 and Figure 12 represent the voltage and current signals in the time domain for the chosen event.

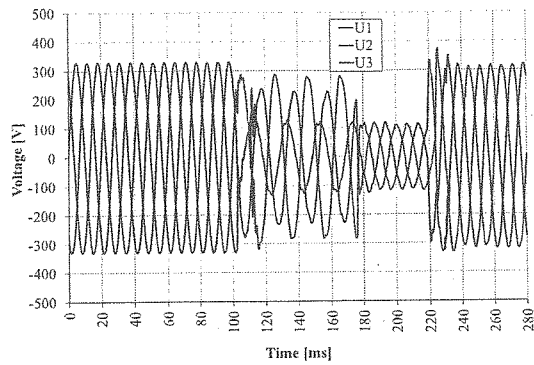

Figure 11: Phase voltages during the selected event.

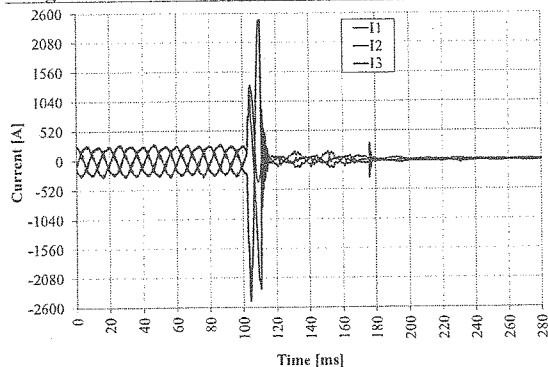

Figure 12: Phase currents during the selected event.

From Figure 12, the contributions of the local system and of the grid to an internal fault event (with non-negligible fault impedance) is well recognizable. On the basis of a three phase power analyzer, with 3 voltmeters in star connection to ground and 3 ammeters per each phase of the PV system, the waveforms displayed in Fig. 12 permit to make the following remarks. From the beginning to 100 ms the initial power flow consists of a substantial amount of active power and very low reactive power supplied by the PV inverters in grid connection. Around the 100-115 ms interval, a three phase fault with unbalanced fault impedances occurs, with consequent over-current peaking up to ten times the pre-fault currents; these current peaks, in all the three phases, are sustained by the grid voltage sources, due to the inability of the PV inverters to provide current much higher than the rated currents. It is worth noting that the fault currents are subject to an abrupt phase-displacement with respect to the voltages. After the previous interval, another interval can be examined from 115 ms to 180 ms, in which the power flow is essentially of reactive nature as the active power generation from the inverters no longer exists. The three voltages are quite lower than the rated value ( $U_2$  is the lowest one,  $U_1$  the highest,  $U_3$  the intermediate) and the currents are very distorted and in lag w.r.t. the voltages. The successive interval around 180-220 ms is characterized by voltages with the same amplitudes (equal to about 1/3 of the rated value) and the currents almost vanishing. Finally, in the last period (220-280 ms) the three phase voltages return to the normal no-generation values (lower than the voltage values when the local generator operates injecting current into the grid and determining a voltage rise).

## 5 CONCLUDING REMARKS

The increasing diffusion of distributed generation and resources in the distribution systems is leading to significant impacts on the quality of power delivery. Today, the aggregated local resources in some countries have reached a level providing relevant implications for the High Voltage grid. The issues emerged have generated an alert coming from the Transmission System Operators, to which the Standards are responding by updating their rules according to the need of avoiding the switch off of the whole amount of local resources when the distribution system is subject to voltage and frequency variation events of relatively limited size. The trend is to establish sound procedures for making the system react to the occurrence of abnormal events in the presence of high uncertainty on the non-programmable generation, by predefining a set of actions that can be activated at the Transmission System Operator's request. Further work will analyse specific events, to monitor the success of the current rules and participate in the discussion towards continuing evolution of the Standards.

## 6 REFERENCES

- [1] G. Chicco, Electricity market evolution in Europe, Scientific Bulletin Electr.Eng. Faculty, Valahia University of Targoviste, year 9, no. 2 (11), 2009, pp.13-22.
- [2] IEEE Standards Coordinating Committee 21, IEEE Standard for Interconnecting Distributed Resources with Electric Power Systems, 28 July 2003.
- [3] N. Jenkins, R. Allan, P. Crossley, D. Kirschen, G.Strbac, Embedded generation, IEE Power and Energy Series 31 (ISBN 0-85296-7748), The IEE, London (2000).
- [4] G.M.S. Islam, A. Al-Durra, S.M. Muyeen, J. Tamura, Low voltage ride through capability enhancement of grid connected large scale photovoltaic system, Proc. 37th Annual Conference IEEE IECON, 2011, 884 - 889
- [5] M. García-Gracia, N. El Halabi, H. Ajami, M. Comech, Integrated Control Technique for Compliance of Solar Photovoltaic Installation Grid Codes, IEEE Trans. on Energy Conversion, 27 (3), 2012, pp. 792-798.
- [6] T. Neumann, I. Erlich, Modelling and control of photovoltaic inverter systems with respect to German grid code requirements, IEEE PES General Meeting, 2012.
- [7] J. Miret, M. Castilla, A. Camacho, L. García de Vicuña, J. Matas, Control Scheme for Photovoltaic Three-Phase Inverters to Minimize Peak Currents During Unbalanced Grid-Voltage Sags, IEEE Trans. Power Electronics, 27 (10), 2012, 4262-4271.
- [8] Autorità per l'energia elettrica e il gas (Italian Authority for Electricity and Gas). See: [www.autorita.energia.it](http://www.autorita.energia.it).
- [9] Terna. Code of transmission, dispatch, development and security of the network (Grid code) (in Italian), [http://www.terna.it/default/Home/SISTEMA\\_ELETTRICO/codice\\_rete.aspx](http://www.terna.it/default/Home/SISTEMA_ELETTRICO/codice_rete.aspx).

- [10] Comitato Elettrotecnico Italiano, Reference technical rules for the connection of active and passive consumers to the HV and MV electrical networks of distribution Company (in Italian). Standard CEI 0-16 (first edition February 2008, second edition July 2008).
- [11] AEEG, Condizioni tecniche per la connessione alle reti di distribuzione dell'energia elettrica a tensione nominale superiore ad 1 kV (in Italian), Deliberation ARG/elt 33/08, 20 March 2008.
- [12] Comitato Elettrotecnico Italiano, Reference technical rules for the connection of active and passive users to the LV electrical Utilities (in Italian). Standard CEI 0-21 (first edition December 2011, second edition July 2012).
- [13] AEEG, Interventi urgenti relativi agli impianti di produzione di energia elettrica, con particolare riferimento alla generazione distribuita, per garantire la sicurezza del sistema elettrico nazionale (in Italian). Deliber. 84/2012/R/EEL, March 2012.
- [14] Terna, Regolazione tecnica dei requisiti di sistema della generazione distribuita (in Italian). Annex A70 to the Italian Grid Code, March 2012.
- [15] Terna, Procedura per la Riduzione della Generazione Distribuita in condizioni di emergenza del Sistema Elettrico Nazionale (RIGEDI) (in Italian). Annex A72 to the Italian Grid Code, August 2012.
- [16] C.L. Fortescue, Method of Symmetrical Coordinates Applied to the Solution of Polyphase Networks, Trans. of the AIEE, Part II, 37, 1918, 1027-1140.