

A W-Band On-Wafer Active Load-Pull System Based on Down-Conversion Techniques

Original

A W-Band On-Wafer Active Load-Pull System Based on Down-Conversion Techniques / Teppati, Valeria; Hansruedi, Benedickter; Diego, Marti; Marco, Garelli; Stefano, Tirelli; Rickard, Lovblom; Ralf, Fluckiger; Maria, Alexandrova; Olivier, Ostinelli; Colombo R., Bolognesi. - In: IEEE TRANSACTIONS ON MICROWAVE THEORY AND TECHNIQUES. - ISSN 0018-9480. - STAMPA. - 62:(2014), pp. 148-153. [10.1109/TMTT.2013.2292042]

Availability:

This version is available at: 11583/2536695 since:

Publisher:

IEEE / Institute of Electrical and Electronics Engineers

Published

DOI:10.1109/TMTT.2013.2292042

Terms of use:

This article is made available under terms and conditions as specified in the corresponding bibliographic description in the repository

Publisher copyright

(Article begins on next page)

A W-Band On-Wafer Active Load-Pull System based on Down-Conversion Techniques

Valeria Teppati, *Senior Member, IEEE*, Hansruedi Benedickter, *Member, IEEE*, Diego Marti, *Student Member, IEEE*, Marco Garelli, *Member, IEEE*, Stefano Tirelli, Rickard Lövblom, Ralf Flückiger, *Student Member, IEEE*, Maria Alexandrova, Olivier Ostinelli, and C. R. Bolognesi, *Fellow, IEEE*

Abstract—A new W-band active load-pull system is presented. It is the first load-pull system to implement a 94 GHz load by means of an active loop exploiting frequency conversion techniques. The active loop configuration demonstrates a number of advantages that overcome the typical limitations of W-band passive tuners or conventional active open loop techniques in a cost effective way: load reflection coefficients Γ_L as high as 0.95 in magnitude can be achieved at 94 GHz, thus providing a nearly full coverage of the Smith Chart. Possible applications of the setup include technology assessment, large-signal device model verification at sub-THz frequencies, and W-band MMIC design and characterization. The availability of direct and accurate load-pull measurements at W-band should prove an asset in the development of sub-THz integrated circuits. First measurements performed on high performance InP double heterojunction bipolar transistors (DHBTs) and GaN high electron mobility transistors (HEMTs) are presented.

Index Terms—Active-device measurements, load pull, nonlinear measurements, transistor measurement, active devices.

I. INTRODUCTION

THE continuous rise of transistor bandwidth and their application at increasingly higher frequencies poses new challenges from a large-signal characterization point of view.

However, measurement systems with large-signal and load-pull capabilities in the W-band are seldom available because traditional passive load-pull techniques [1], [2] have consistent drawbacks and limitations at millimeter-wave and higher frequencies.

The main drawback of traditional passive tuners at high frequencies is that they can realize relatively high reflection coefficients (Γ) – typically exceeding 0.9 in magnitude at their coaxial or waveguide ports – but when characterizing on-wafer devices, the set-up losses (probes and transmission lines) will significantly lower the maximum reachable Γ . Of course, this limitation worsens with increasing frequencies. Typical losses in W-band on-wafer set-ups are rarely less than 1-2 dB; 1 dB losses transform an ideal 1 magnitude reflection coefficient to 0.8 magnitude, while losses amounting to 2 dB lower it to 0.63.

The authors are with the Millimeter-Wave Electronics (MWE) Group, ETH-Zürich, 8092 Zürich, Switzerland (e-mail: valeria.teppati@mwe.ee.ethz.ch, colombo@ieec.org). Marco Garelli is with HFE, High Frequency Engineering Sagl (support@hfemicro.ch). This work was partially funded by the Swiss National Science Foundation (SNSF), with grants R'Equip n. 206021_144952/1 and MHV n. PMPDP2_139697 and by ETH Zürich, with Scientific Equipment Program n. 03721. It was carried out at the MWE Laboratory, ETH Zürich, 8092 Zürich, Switzerland.

The few reports of W-band measurement systems involving passive tuners all suffer from this limitation [3]–[7], presenting maximum reachable Γ of 0.5-0.6 magnitude. An improvement to this approach is available with probe integrated tuners as in [8], but this solution as well offers a limited Γ (0.82 at 100 GHz). Moreover, accuracy can be an issue in such implementations, as they are intrinsically *non-real-time* [9].

As recently investigated in [10], the non-real-time measurement approach (exploiting tuning element pre-characterization) has severe accuracy limitations with respect to the real-time one (not needing pre-characterization and continuously measuring the quantities of interest). To quantify this, consider that typical errors on the transducer gain can reach 0.2 dB for a 0.7 magnitude Γ in a real-time system, and 1 dB in a non-real-time one on the same Γ , unless particular strategies for error reduction are used [10].

This aspect of course becomes even more critical as frequency increases. A real-time approach, nevertheless, requires the presence of measurement directional couplers between probes and tuning element (as shown in Figure 1), thus increasing losses. In other words, a load-pull measurement system using a passive tuner only, will either be inaccurate or show an insufficient $|\Gamma|$. The implication is that at least a small part of the load must be active to achieve sufficiently high reflection coefficients with the more accurate real-time measurement strategy.

Unfortunately, applying the traditional active open- or closed-loop techniques – firstly introduced respectively in [11] and [12] – in the W-band is not straightforward. Components such as electronically controlled phase shifters and very narrow band bandpass filters (BPF) are not easily found and very expensive. The highly selective Yttrium Iron Garnet (YIG) filters often used for the closed-loop active load to avoid oscillations are not available in W-band. The open-loop active load, on the other hand, suffers from the disadvantage of being difficult to control during a power sweep. As a matter of fact, in [13] a W-band active open-loop load-pull system based on 6-port reflectometers was presented. It had the capability of measuring constant (small-signal) power circles, but, not surprisingly, no power sweeps were shown.

After consideration of the above, we chose to exploit the concept of down-conversion by realizing a 94 GHz closed-loop active load. To the best of our knowledge, this was never done before as the existing implementation of active loads exploiting mixing/down-conversion are either open-loop solutions [14]–[16] or closed-loop at much lower envelope

frequency [17].

In the following, Section II describes the system realization in detail, as well as its calibration, verification and accuracy assessment. Section III reports the first on-wafer measurements performed on active devices with this system. Finally, Section IV draws the conclusions of this work.

II. THE NOVEL MEASUREMENT SYSTEM

Figure 1 shows a simplified schematic of our load-pull system, based on a HP8510 Vector Network Analyzer (VNA) with an HP85105A Millimeter-Wave Controller, external couplers, harmonic mixers and additional signal sources. Table I reports the main specifications of some of the most important components in the system.

TABLE I
 SYSTEM COMPONENTS MAIN SPECIFICATIONS. NAMES OF THE COMPONENTS REFER TO FIGURE 1.

Device	Bandwidth (GHz)	Additional information
x6 multimp	75-110	3 dBm max output power
ATT1	75-110	0.3-23 dB attenuation
ATT2	8-18	2-60 dB attenuation
AMP1	92-96	Psat = 21.7 dBm
AMP2	92-96	Psat = 27 dBm
C1-C3	75-110	20 dB coupling
M1-M4	75-110	42-45 dB conv. loss
F1	9.585-9.615	fixed frequency
PH1	7-12	0°-400° @ 9.6 GHz
M5-M6	82-105	7-10 dB conv. loss
LO	75-110	P = 10 dBm
F2	92-inf	fixed frequency

The set-up exploits down-conversion harmonic mixers HP11970W (M1-4) for the measurement of the incident (a_1 and a_2) and reflected (b_1 and b_2) waves, separated by dual directional couplers (C1 and C3) at the input and at the output of the Device Under Test (DUT). The input signal is sent to a $\times 6$ multiplier (HP83558A) and amplified at 94 GHz with AMP1. The manual variable attenuator ATT1 is used for the coarse control of the input power and typically for protection of the smaller devices. All power sweeps are performed automatically by driving the multiplier input. The nonlinearities in the multiplier output are compensated via software, and thus present no issue.

The part of the system between points A and B is realized with WR10 waveguide components and, excluding AMP1, AMP2 and F2, it covers the entire W-band.

The principal innovation in our load-pull system is the output load implementation. It is an active loop based on down-conversion: fundamental mixer M5 is used to down-convert the signal to 9.6 GHz, which is then filtered with a 30 MHz bandwidth filter centered at 9.6 GHz (F1). The magnitude and phase of the signal are controlled via an electronic variable attenuator (ATT2) and an electronic phase shifter (PH1), finally the signal is up-converted with fundamental mixer M6. The signal is then re-injected back at the DUT output, in point B, high-pass filtered (F2) to cancel the LO feed-through and lower side-band and finally amplified (AMP2) at 94 GHz.

Note that due to the position of the loop coupler C2 [18] and the presence of the narrow band BPF F1 in the loop (30 MHz bandwidth), the risk of loop oscillations is greatly reduced [19]. As a matter of fact, oscillations were never experienced during various experiments with different transistor types. A spectrum analyzer, not shown in Figure 1 for simplicity, is always connected to the X-band part of the loop (after ATT2, through a directional coupler) and monitors for possible issues.

The system is completed by power supplies and multimeters to set and measure the DUT bias and by an advanced automation software tool [20]. Bias tees are integrated in the waveguide probes (GGB 120-GSG-125-BT).

The proposed method for electronic synthesis of the load was never applied before at W-band, but it offers a number of advantages at such high frequencies. In first place, the higher losses at W-band mainly due to the probes (and consequently unavoidable) are compensated by the active load. Thus, within the Smith Chart, a very high $|\Gamma_L|$ is achievable, the only limitation being the available power from the output amplifier AMP2. Then, some of the most expensive parts in W-band – the computer controlled variable attenuator and phase shifter as well as the filter – are substituted by their X-band counterparts.

Another important advantage is that, due to the loop, Γ_L is intrinsically constant during a power sweep, making this technique safer and more straightforward with respect to open loop techniques which always require some kind of feedback during a power sweep. The measurement directional couplers C1 and C3 perform measurements in real-time, thus increasing the system accuracy [10]. The system's dynamic range was evaluated and it is approximately 55 dB for 0 dBm power at the probe tips with 64 averages. As will be shown in the following, this value is enough to achieve extremely good accuracy, as it mostly depends on standard definition and cable stability.

Finally, for what concerns the possibility of changing the fundamental frequency within the W-band, the down-conversion loop technique has an important advantage with respect to direct techniques. By simply changing the LO frequency (which in our implementation is delivered by an active full W-band $\times 6$ multiplier), it is not necessary to change the IF frequency and consequently any of the X-band components, nor the center frequency of the loop filter F1. The most critical components are therefore amplifiers AMP1 and AMP2, since available parts are typically narrow-band, but an open-loop system would suffer from the same limitations.

A. Calibration

The system is first calibrated with a VNA-like calibration at ports 1 and 2. For this calibration step, the manual switches SW1 and SW2 are both switched to position 1. This allows the signal source to be set at each port, while the remaining port is terminated by a matched load (not shown in the schematic for simplicity's sake). The chosen calibration algorithm for the experiments was a Thru-Reflect-Match (TRM), using an on-wafer 1 ps thru connection, a matched load and a short type "reflect." Calibrating the system with Thru-Reflect-Line (TRL) algorithm is also possible.

The subsequent step is the power calibration, performed with a power meter connected at a waveguide reference plane

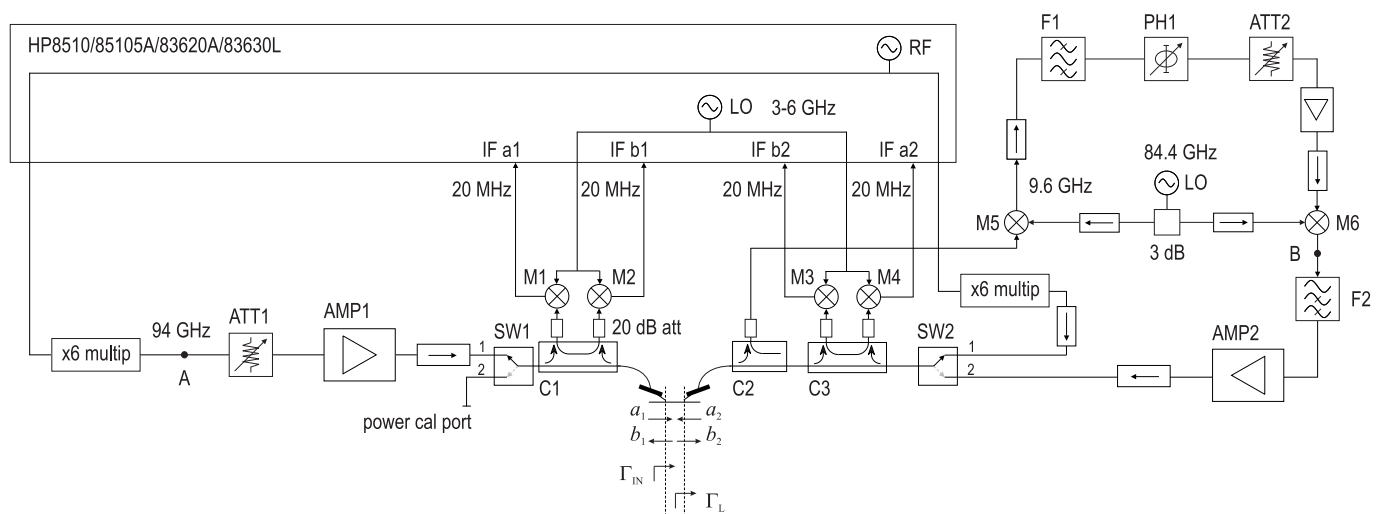

Fig. 1. Simplified schematic of the W-band active load-pull system.

(“power cal port” in Figure 1), with a similar technique to [21]. During this phase, switch SW1 is turned in position 2, while SW2 stays in position 1. A waveguide short, offset short and matched load are also connected at the waveguide reference plane, thus the power measurement is correctly translated to the on-wafer reference plane, via a one-port calibration.

During load-pull measurements, SW1 will be turned again in position 1, while SW2 is turned in position 2. Note that the presence of these switches, which greatly simplifies the system operation, does not affect calibration or the system accuracy in any way. No particular requirement on the switch repeatability exists. This is because the switches lay “outside” the signal path linking the reflectometers to the on-wafer reference planes.

B. Quantities of interest definition

The actually measured quantities at microwaves are the incident and reflected waves (a_1 , a_2 , b_1 , b_2) while, in DC, the input and output voltages (V_{DC1} and V_{DC2}) and currents (I_{DC1} and I_{DC2}) are measured.

The main interest quantities derived from the former are here defined:

- Input reflection coefficient, $\Gamma_{IN} = \frac{b_1}{a_1}$,
- Load reflection coefficient, $\Gamma_L = \frac{a_2}{b_2}$,
- Input Power, $P_{IN} = |a_1|^2 - |b_1|^2$,
- Output Power, $P_{OUT} = |b_2|^2 - |a_2|^2$,
- Operating Gain, $G_{OP} = \frac{P_{OUT}}{P_{IN}}$,
- DC Power, $P_{DC} = V_{DC1} \cdot I_{DC1} + V_{DC2} \cdot I_{DC2}$,
- Power Added Efficiency, $PAE = \frac{P_{OUT} - P_{IN}}{P_{DC}}$.

C. Residual uncertainty

As shown in [10], residual uncertainty can be well estimated by measuring an on wafer “thru” connection while changing the loading conditions Γ_L throughout the entire Smith Chart. Then, the difference between the measurement and the theoretical value of a certain parameter is taken as an estimate of residual uncertainty.

In [10] it was found that the best parameter to consider when reaching very high reflection coefficients (at least > 0.8 in magnitude) is the operating gain G_{OP} , which, for a thru, has an ideal value of 0 dB throughout the entire Smith Chart. The reason is that G_{OP} has a higher sensitivity to residual uncertainty for high $|\Gamma_L|$ values than other types of gain, for example, the transducer gain.

In this work, ΔG_{OP} , i.e. the difference of the measured G_{OP} and 0 dB, is thus taken as an estimate of residual uncertainty.

Several measurements were performed on days following the system’s first calibration. After four days, if the HP8510 system is not turned off, the residual uncertainty remains indistinguishable from the one estimated immediately after a fresh calibration.

The system residual uncertainty ΔG_{OP} is extremely good for $|\Gamma_L| < 0.8$, not exceeding ± 0.1 dB. It then reaches ± 0.5 dB for $|\Gamma_L| = 0.95$. These performances are comparable to or even better than lower frequency real-time load-pull systems.

In Figure 2 our new HP8510-based 94 GHz system

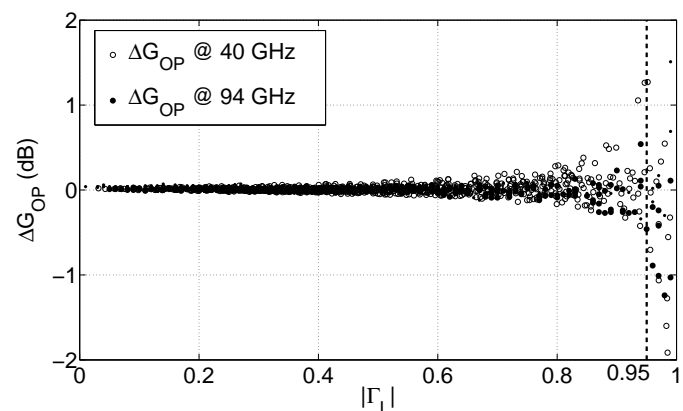

Fig. 2. Measured residual uncertainty ΔG_{OP} , for the novel 94 GHz load-pull system and a 40 GHz PNAX-based system.

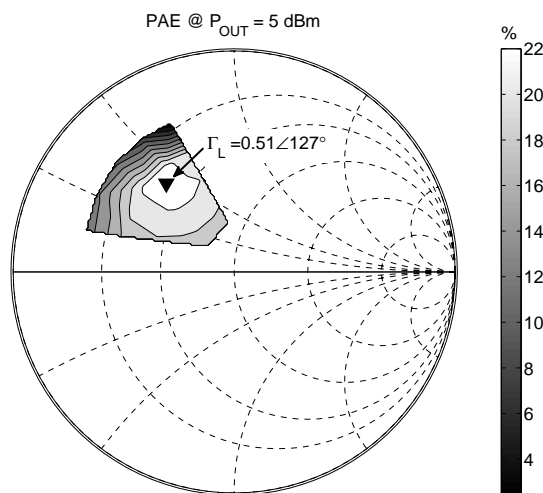

Fig. 3. Measured InP/GaAsSb DHB T load-pull map. Contours of PAE when $P_{OUT} = 5$ dBm are shown. The best reflection coefficient for this performance is $\Gamma_L = 0.51 \angle 127^\circ$, at 94 GHz.

and a PNAX-based 40 GHz real-time system are compared uncertainty-wise. The 94 GHz performance is even slightly better than that at 40 GHz. This should not surprise even if the 40 GHz system is based on a higher dynamic range and more modern VNA, because the residual uncertainty main contributions are not due to VNA uncertainty but to standard definition and cables/connections stability. The slightly better accuracy at 94 GHz can thus be explained by the higher stability of waveguide transmission lines and connections at 94 GHz with respect to coaxial cables and connectors, used at 40 GHz.

III. MEASUREMENT EXAMPLE

We now provide measurement examples on high speed InP HBTs and GaN HEMT mm-wave transistors. Figures 3 and 4 show results obtained at 94 GHz with a $0.3 \times 8.4 \mu\text{m}^2$ InP/GaAsSb DHB T, biased in class AB ($V_{BE} = 0.75$ V, $V_{CE} = 1.6$ V). For this bias point, taking into account self bias when the device is measured in large signal conditions,

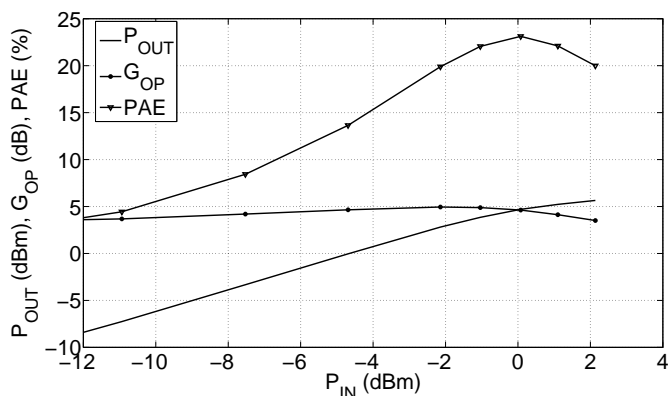

Fig. 4. Measured power sweep of the InP/GaAsSb DHB T device of Figure 3, in class AB at 94 GHz, on the best load for PAE when $P_{OUT} = 5$ dBm ($\Gamma_L = 0.51 \angle 127^\circ$).

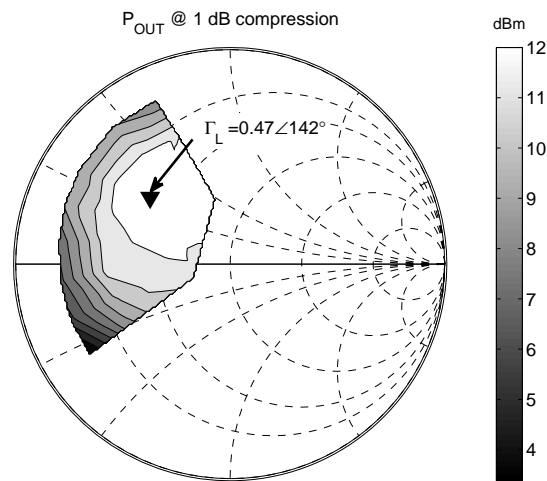

Fig. 5. Measured GaN HEMT load-pull map. Contours of P_{OUT} @ 1 dB compression are shown. The best reflection coefficient for this performance is $\Gamma_L = 0.47 \angle 142^\circ$, at 94 GHz.

the device's f_T and f_{MAX} exceed (roughly) 300 and 330 GHz respectively.

As can be seen from Figure 4, for this bias condition, the DHB T output power P_{OUT} reaches 6 dBm in deep compression, thus posing no challenges in setting any active load with a 25 dBm output power (at 1 dB compression) amplifier AMP2 [22], [23].

A more critical situation is experienced when measuring GaN HEMTs. In Figures 5 and 6 we show the measurements of a $0.1 \times 100 \mu\text{m}^2$ GaN HEMT, biased in class A ($V_{DS} = 5$ V, $V_{GS} = -1.3$ V). With this bias, the device shows an f_T and an f_{MAX} of approximately 100 and 180 GHz, respectively.

The on-wafer output power reached by these devices for the chosen bias point is around 17 dBm, and the maximum reachable $|\Gamma_L|$ with the 25 dBm AMP2 is, experimentally, 0.85. As shown in Figure 5, this is sufficient for this device, since its output power peaks for $\Gamma_L = 0.47 \angle 142^\circ$. By using the 30 dBm amplifier for AMP2, it is possible to reach a reflection coefficient of 0.95.

For what concerns average currents, a comparison of the

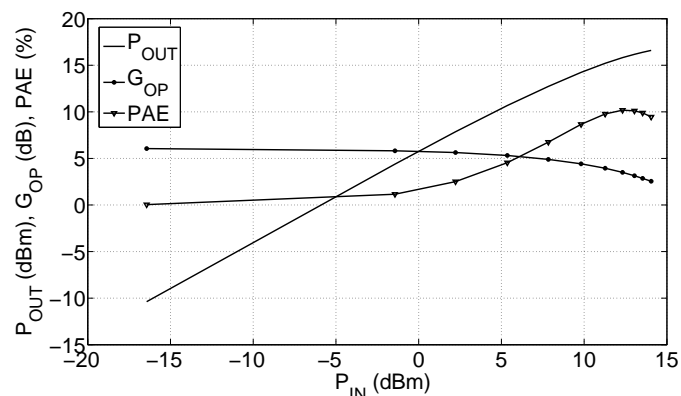

Fig. 6. Measured power sweep of the GaN HEMT device of Figure 5, in class A at 94 GHz, on the best load for output power at 1 dB compression ($\Gamma_L = 0.47 \angle 142^\circ$).

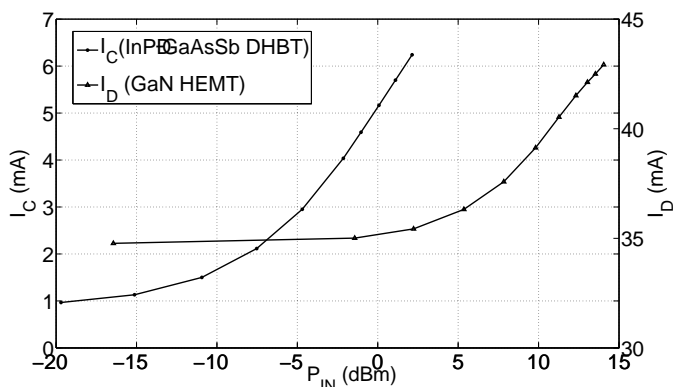

Fig. 7. Collector and drain average currents measured during the power sweeps reported in Figures 4 and 6.

collector and drain average currents during the optimal power sweeps of Figures 4 and 6 is shown in Figure 7.

As a final remark, the worst case load stability, i.e. at the maximum mismatch, is ± 0.01 on the load magnitude and $\pm 1.5^\circ$ on load phase. This was obtained without any form of iterative algorithm or feedback, except the one intrinsic in the active loop, thus making the measurements as fast as possible. The measurement speed is in fact only determined by the chosen number of VNA averages.

IV. CONCLUSIONS

We have presented the first realization of a real-time 94 GHz load-pull system based on a down-conversion active closed-loop. With the proposed technique, crucial loop components operate in the X-band, thus costs are considerably reduced. The set-up provides a high accuracy, due to the real-time measurement technique, very high reachable reflection coefficients and highly stable load during power sweeps. Measurements performed on high f_T/f_{MAX} transistors were shown. Possible applications include technology assessment, large-signal device model verification at sub-THz frequencies, and W-band MMIC design and characterization.

REFERENCES

- [1] G. Simpson, "A comparison of harmonic tuning methods for load pull systems," *Mauray Microwave Corporation Application note 5C-053*, pp. 1-8, Feb. 2004.
- [2] Focus Microwaves, "An affordable harmonic load pull setup," *Microwave J.*, pp. 180-182, Oct. 1998.
- [3] E. Alekseev, D. Pavlidis, and C. Tsironis, "W-band on-wafer load-pull measurement system and its application to HEMT characterization," in *IEEE MTT-S Intl. Microwave Symp. Dig.*, Baltimore, MD, USA, Jun. 1998, pp. 1479-1482.
- [4] D. W. Baker, R. S. Robertson, R. T. Kihm, M. Matloubian, M. Yu, and R. Bowen, "On-wafer load pull characterization of W-band InP HEMT unit cells for CPW MMIC medium power amplifiers," in *IEEE MTT-S Intl. Microwave Symp. Dig.*, Anaheim, CA, USA, Jun. 1999, pp. 1743-1746.
- [5] L. Boggione and R. T. Webster, "200 GHz f_T SiGe HBT load pull characterization at mmwave frequencies," in *IEEE Radio Frequency Integrated Circuits Symposium (RFIC)*, Anaheim, CA, USA, Jun. 2010, pp. 215-218.
- [6] C. Li, L. B. Lok, A. Khalid, I. G. Thayne, and D. R. S. Cumming, "Investigation of loading effect on power performance for planar Gunn diodes using load-pull measurement technique," *IEEE Microwave and Wireless Components Letters*, vol. 21, no. 10, pp. 556-558, Oct. 2011.

- [7] A. Pottratin, T. Lacave, D. Ducatteau, D. Gloria, P. Chevalier, and C. Gaquière, "High power density performances of SiGe HBT from BiCMOS technology at W-band," *IEEE Electron Device Letters*, vol. 33, no. 2, pp. 182-184, Feb. 2012.
- [8] T. V. Heikkilä, J. Varis, J. Tuovinen, and G. M. Rebeiz, "W-band RF MEMS double and triple-stub impedance tuners," in *IEEE MTT-S Intl. Microwave Symp. Dig.*, Long Beach, CA, USA, Jun. 2005, pp. 923-926.
- [9] V. Teppati, A. Ferrero, and U. Pisani, "Recent advances in real-time load-pull systems," *IEEE Trans. Instr. Meas.*, vol. 57, no. 11, pp. 2640-2646, Nov. 2008.
- [10] V. Teppati and C. R. Bolognesi, "Evaluation and reduction of calibration residual uncertainty in load-pull measurements at millimeter-wave frequencies," *IEEE Trans. Instr. Meas.*, vol. 61, no. 3, pp. 817-822, Mar. 2012.
- [11] Y. Takayama, "A new load-pull characterization method for microwave power transistor," in *IEEE MTT-S Intl. Microwave Symp. Dig.*, Cherry Hill, NJ, Jun. 1976, pp. 218-220.
- [12] G. Bava, U. Pisani, and V. Pozzolo, "Active load technique for load-pull characterization at microwave frequencies," *Electronic Lett.*, vol. 18, pp. 178-179, Feb. 1982.
- [13] S. A. Chahine, B. Huyart, E. Bergeault, and L. P. Jallet, "An active millimeter load-pull measurement system using two six-port reflectometers operating in the W-frequency band," *IEEE Trans. Instrum. Meas.*, vol. IM-51, pp. 408-412, Jun. 2002.
- [14] M. Marchetti, M. Pelk, K. Buisman, W. Neo, M. Spirito, and L. de Vreede, "Active harmonic loadpull with realistic wideband communications signals," *IEEE Trans. Microwave Theory Tech.*, vol. 56, no. 12, pp. 2979-2988, Dec. 2008.
- [15] L. Galatro, M. Marchetti, and M. Spirito, "60 GHz mixed signal active load-pull system for millimeter wave devices characterization," in *Microwave Measurement Symposium (ARFTG), 2012 80th ARFTG*, San Diego, CA, Nov. 2012, pp. 1-6.
- [16] M. Spirito, M. Pelk, F. van Rijns, S. J. C. H. Theeuwens, D. Hartskeerl, and L. de Vreede, "Active harmonic load-pull for on-wafer out-of-band device linearity optimization," *Microwave Theory and Techniques, IEEE Transactions on*, vol. 54, no. 12, pp. 4225-4236, Dec. 2006.
- [17] T. Williams, J. Benedikt, and P. Tasker, "Experimental evaluation of an active envelope load pull architecture for high speed device characterization," in *IEEE MTT-S Intl. Microwave Symp. Dig.*, Long Beach, CA, Jun. 2005, pp. 1509-1512.
- [18] A. Ferrero, "Active load or source impedance synthesis apparatus for measurement test set of microwave components and systems," *United States Patent n. 6509743*, 12 Jun. 2000.
- [19] V. Teppati, A. Ferrero, and G. L. Madonna, "Load- and source-pull techniques," in *Modern RF and Microwave Measurement Techniques*, ser. The Cambridge RF and Microwave Engineering Series, V. Teppati, A. Ferrero, and M. Sayed, Eds. Cambridge University Press, Jul. 2013, pp. 342-380.
- [20] HFE Sagl, MMSNT LP Software. [Online]. Available: www.hfemicro.com
- [21] A. Ferrero and U. Pisani, "An improved calibration technique for on-wafer large-signal transistor characterization," *IEEE Trans. Instrum. Meas.*, vol. IM-47, pp. 360-364, Apr. 1993.
- [22] Z. Aboush, C. Jones, G. Knight, A. Sheikh, H. Lee, J. Lees, J. Benedikt, and P. Tasker, "High power active harmonic load-pull system for characterization of high power 100-watt transistors," in *Microwave Conference, 2005 European*, vol. 1, 2005, pp. 4 pp.-.
- [23] M. Marchetti, R. Heeres, M. Squillante, M. Pelk, M. Spirito, and L. de Vreede, "A mixed-signal load-pull system for base-station applications," in *Radio Frequency Integrated Circuits Symposium (RFIC), 2010 IEEE*, 2010, pp. 491-494.

Valeria Teppati (S'01-M'03-SM'12) was born in Torino, Italy. She received the Laurea degree (Summa cum Laude) in electronic engineering and the Ph.D. degree in Electronic Instrumentation from Politecnico di Torino, Torino, in 1999 and 2003, respectively. In 2003, she joined the Department of Electronics, Politecnico di Torino, as a Research and Teaching Assistant, where she has been an Assistant Professor since 2005. From December 2010 to March 2011, she has been a Visiting Professor with the Millimeter-Wave Electronics (MWE) Group, at ETH (Eidgenössische Technische Hochschule) Zürich, Switzerland. Since May 2012 she is with the same group as a researcher, with a grant funded by the Swiss National Science Foundation, n. PMPDP2_139697. Her main research interests include microwave devices

design, linear and nonlinear measurement design and automation, load-pull, differential load-pull, multiport vector network analyzers and their calibration and uncertainty.

Hansruedi Benedickter (S'81-M'85) was born in 1951, in Zug, Switzerland. He received the Diploma degree in electrical engineering from ETH Zürich, Switzerland, in 1976. He has been a Research Assistant and a Senior Research Associate at the Microwave Laboratory, ETH, since 1987 at the Laboratory for Electromagnetic Fields and Microwave Electronics and since 2009 at the Laboratory for Millimeter-Wave Electronics (MWE) ETH Zürich. His main research interests are microwave, millimeter-wave, and on-wafer measurement techniques.

Diego Marti (S'09) was born in Zürich, Switzerland. He received his M. Eng. Degree from Swiss Federal Institute of Technology (ETH) in 2009. In 2009 he joined the Millimeter-Wave Electronics Group at the ETH where he is working toward the Ph.D. degree. His research interests are in process development and fabrication of high power, high frequency Gallium Nitride high electron mobility transistors (HEMTs) and in design and fabrication of monolithic microwave integrated circuit (MMIC) power amplifiers (PAs).

Marco Garelli (S04-M'10) was born in Cuneo, Italy, in 1981. He received his Electronic Engineering degree in 2005, and in 2008 his Ph.D degree in Metrology at the Politecnico di Torino, Italy. During 2007 and 2008 he was guest researcher at the National Institute of Standards and Technology in Boulder, CO. He worked as independent consultant in 2008 and 2009, then he joined HFE, High Frequency Engineering Sagl, in 2010 as Chief Technical Officer. His main interests are in the area of RF and microwave measurement techniques, calibration and uncertainty, large-signal and noise parameters measurements.

Stefano Tirelli is currently pursuing the Ph.D. degree with the Millimeter-Wave Electronics Group, Swiss Federal Institute of Technology, Zurich, Switzerland. His current research interests include physical limits for the development and implementation of high power HEMTs.

Rickard Lövblom received the M.Sc. degree in electrical engineering from Lund University, Sweden, in 2008. He is currently working toward the Ph.D. degree in the Millimeter-Wave Electronics Group at ETH Zürich, Switzerland, where his main research area is the design and fabrication of high-speed heterojunction bipolar transistors.

Ralf Flückiger (S'12) is currently pursuing a Ph.D degree with the Millimeter-Wave Electronics Group at the Swiss Federal Institute of Technology, Zürich, Switzerland. His research interests include the design and fabrication of double heterojunction bipolar transistors and monolithic microwave integrated circuits.

Maria Alexandrova received her M. Physics Degree from Moscow Institute of Physics and Technology (MIPT), Russia in 2010. In 2011 she joined the Millimeter-Wave Electronics Group at the Swiss Federal Institute of Technology, Zürich, Switzerland where she is pursuing a Ph.D degree. Her research interests include design and fabrication of double heterostructure bipolar transistors (DHBTs).

Olivier Ostinelli was born in Lugano, Switzerland. He received his Ph.D. from the Swiss Federal Institute of Technology (ETH) in 2006. In 2006 he joined the Millimeter-Wave Electronics Group at ETH. His research work focuses on the crystal growth of InP based double heterojunction bipolar transistors (DHBTs) and high electron mobility transistors (HEMTs).

C. R. Bolognesi (S'84-M'94-SM'03-F'08) was born in St-Lambert, QC, Canada. He earned the B.Eng. degree from McGill University in Montreal, QC (1987), the M.Eng. degree from Carleton University in Ottawa, ON, Canada (1989), and the Ph.D. degree from University of California, Santa Barbara (1993), in Electrical Engineering. In 1994 he joined Northern Telecom in Ottawa, Canada, as a BiCMOS Process Integration Engineer in charge of high-performance submicrometer polysilicon emitter BJTs with selectively-implanted pedestal collectors. From 1995 to 2006, he was in turn Assistant, Associate and Full Professor with the Engineering Science and Physics Departments at Simon Fraser University in Burnaby BC, Canada where he founded and directed SFU's Compound Semiconductor Device Fabrication Laboratory. In 2006, he relocated to the Swiss Federal Institute of Technology in Zürich (ETH-Zürich) to direct the Millimeter-Wave Electronics Group. Professor Bolognesi's research interests involve the development, characterization and application of high-performance millimeter-wave devices based on advanced material systems such as InP/GaAsSb double heterojunction bipolar transistors (DHBTs) and InP/GaInAs and (Al,Ga,In)N/GaN high electron mobility transistors (HEMTs).