

SMART DATA COMMUNICATION SOLUTIONS FOR SMALL SATELLITES

Original

SMART DATA COMMUNICATION SOLUTIONS FOR SMALL SATELLITES / Mughal, M.R., Ali, A., Reyneri, L.. - IAC-13,B4,6A,7,x19005:(2013), pp. 1-6. (International Astronautical Conference Beijing).

Availability:

This version is available at: 11583/2530691 since:

Publisher:

International Astronautical Federation (IAF)

Published

DOI:

Terms of use:

This article is made available under terms and conditions as specified in the corresponding bibliographic description in the repository

Publisher copyright

(Article begins on next page)

IAC-13,B4,6A,7,x19005

SMART DATA COMMUNICATION SOLUTIONS FOR SMALL SATELLITES

M. Rizwan Mughal, Anwar Ali, Leonardo M. Reyneri
Department of Electronics and Telecommunications,
Politecnico Di Torino, Italy
{muhammad.mughal, anwar.ali, leonardo.reyneri}@polito.it

Data Communication and data handling system in an electronic system design has analogy of blood circulation in every human system. If the system is well designed, robust communication channel can be achieved. The main constraint in the design of small satellites is the available space. AraMiS satellite employs a novel design approach, based on tiles, which is quite flexible and modular. A number of sensors, actuators and other small modules are present on every tile using a plug and play approach. The communication of housekeeping data of different sensors within a tile and across the tiles, managed by on-board computer, can either be done using wired approach or wireless approach. This work focusses on data communication solutions using wireless approach. Two types of communications systems have been tested on-board AraMiS, infrared optical and Radio Frequency based.

The optical communication system largely consists of electronic and optical components. The input data stream from any module is sent through encoder, driver and IRLED at the transmit side and data is available at receive side through photo-detector, amplifier and comparator stages. The channel used for communication can either be FSO or glass fibre. An innovative design of placing glass fibre for reliable communication across the tiles has been discussed. The optical light has been guided in certain directions using double surface mirrors. Theoretical and measurement results are in close comparison with each other. Every tile hosts two tiles processors (MSP430 controllers), responsible for communication across different nodes.

After much literature review, radio frequency communication system has been developed using TI CC2510 and CC1110 transceiver modules. The protocol stack has been kept compliant with propriety simpliciTI protocol. The receive signal strength for different variable power levels have been computed and plotted. The packet format for the receive packets has been detected using a commercial packet sniffer software and the received packets from different radio transceivers have been received with a very small packet error rate. We are able to transmit packets with output transmit power as low as up to -30dBm with acceptable average RSSI.

A complete mapping strategy for wireless communication protocols has been formed considering the limited communication channels available on board the small satellites. All the possible communication systems have been made complaint with the basic protocol of the AraMiS so that the end user is able to use them without knowing much detail about the physical layer of each protocol.

I. INTRODUCTION

Modular or module based design is a design approach based on dividing a system into smaller parts or modules that can be created independently and assembled together to achieve the desired performance of the complete system. This design approach is in general low cost because the design, qualification and test cost is shared among multiple modules. The modules are developed in parallel rather than typical system developed in serial and results in reduction of the design time. Modular design combines the advantages of standardization with those of customization. The AraMiS architecture is based on standardized panel bodies or blocks called *tiles*. These are used to build small satellites according to the specific requirements [1-2]. Each tile offers a power and data standardized interface with mechanical support for small subsystems. The outer *tiles* are of two types

namely power management tile and telecommunication tile. Power management tile is composed mostly of solar panels, rechargeable batteries, battery charger, housekeeping module to keep track telemetry data inside the tile and an active magnetic and inertial control system. An appropriate number of such tiles are placed around a cubic or any other desired shape and represent a pre-designed and pre-assembled modular architecture. Telecommunication tiles are composed of microcontroller-based programmable transceiver, 437MHz or 2.4GHz modem, power amplifier (for transmission) and low-noise amplifiers (for reception) and an antenna system. This kind of tile is placed on one of the faces of the satellite, preferably pointing to ground, and manages exchange of data and commands to/from ground stations.

The paper is organized according to the following sequence. Section II discusses the wired data communication solutions for AraMiS architecture. Section III discusses the wireless communication

solutions onboard small satellites with section IV being conclusion of the paper.

II. WIRED COMMUNICATION SOLUTIONS

AraMiS architecture employs basic protocol which initiates communication between tile processor and pluggable module. The basic protocol supports multiple communication protocols including RS232 UART, IrDA, SPI, and I²C communication protocols [3-4] for modules that are connected using a wired approach. The wired communication solution has been implemented on AraMiS tiles and detailed in [5].

RS232

A standard UART communication in RS232 asynchronous mode requires two external pins, transmit and receive, namely UCAXRXD and UCAXTXD for tile processor [6]. Connector pin RX is internally connected to the UCAXRXD pin of the microcontroller and TX is connected to the UCAXTXD of the microcontroller. At most 4 UARTs are available on the MSP430, so RS232 signals are only available on modules A, C, E, G.

IrDA

The IrDA encoder sends a pulse for every zero bit in the transmit bit stream coming from the RS232 UART. It also uses UCAXRXD and UCAXTXD only to be configured for IrDA in software. Therefore as in case of RS232, IrDA is only available on modules A, C, E, G.

I²C

I²C is a two wire protocol that requires only two lines, i.e. serial data (SDA) and serial clock (SCL). In a single master scheme, as many slave devices can be connected to SDA and SCL lines. In order to use I²C, all SCL and SDA signals are shared in pairs i.e. connectors A, B share same I²C channel. Similarly pair C, D; pair E, F & pair G, H share the I²C signals. SCL and SDA signals are connected to UCBxSCL and UCBxSDA signals respectively.

SPI

SPI is either three or four wire protocol that requires slave out master in (SOMI), slave in master out (SIMO) and clock (CLK) signals. Optional active low slave transmit enable (STE) or EN signal may also be needed in some cases. Modules B, D, F, H have capability of SPI protocol whereas modules A, C, E, G can be configured for SPI if not configured for RS232 mode. System level configuration of cube architecture is shown in Fig.1. It shows the inter tile communication and kill switch interface using I²C communication. Telecommunication tile, additionally, uses SPI for communication of S band CC2510 transceiver with the on board computer. The central power distribution bus distributes the power and reference voltage signals to

each tile and ultimately corresponding modules using a centralized scheme. As soon as the kill switch is released, it sends to OBC a wake up interrupt and ultimately the OBC turns PDB on and also sends enable signal to all the tiles using I²C interface.

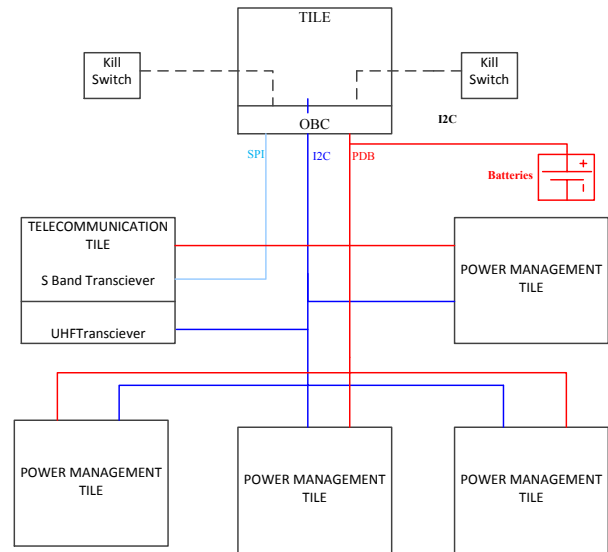

Fig.1 System level connection of different tiles through Inter tile communication and power distribution bus

III. WIRELESS COMMUNICATION SOLUTIONS

III.I. INFRARED COMMUNICATION SYSTEM

A number of configurations for reliable communication for inter and intra tile communications using the proposed transceiver were studied and the best proposed implementation structure is shown in the Fig 2. For experimental purposes, a no. of glass materials were evaluated for short range communication purposes inside the satellite. *Plexiglass* or *polymethyl methacrylate*, which is a strong, transparent polymer plastic glass showed the best results with respect to the transmission of infrared light in the laboratory conditions. This material has still not been tested in radiation environment. Fig. 2 shows the assembly of six tiles to make a cube structure for AraMiS and possible configuration of glass fiber for inter as well intra tile communication. This configuration is used for communication from one tile to any other tile. Each tile uses four double reflector mirrors placed on different positions at certain angles in front of the junction of every four glass fibres. The proposed configuration uses communication in both ways using two separate channels as shown in the Fig. 2. The reflecting mirrors are placed in such a way that half of the incoming light signal passes straight through and half of it is reflected

at right angle to the incident signal. Figure shows the detailed view of the architecture. The only shortcoming of this scheme is that some receiving nodes that are close to the transmitters receive high light intensity while the nodes that are placed much far from the transmitter receive very small amount of infrared light. This needs a receiver with high dynamic range to receive from very small currents up to orders of nA to large currents up to orders of some mA . A discrete high dynamic range receiver has been designed [7] for this purpose. The mirrors are double reflectors so the transmission can be carried out either way by putting the transmitters at different positions.

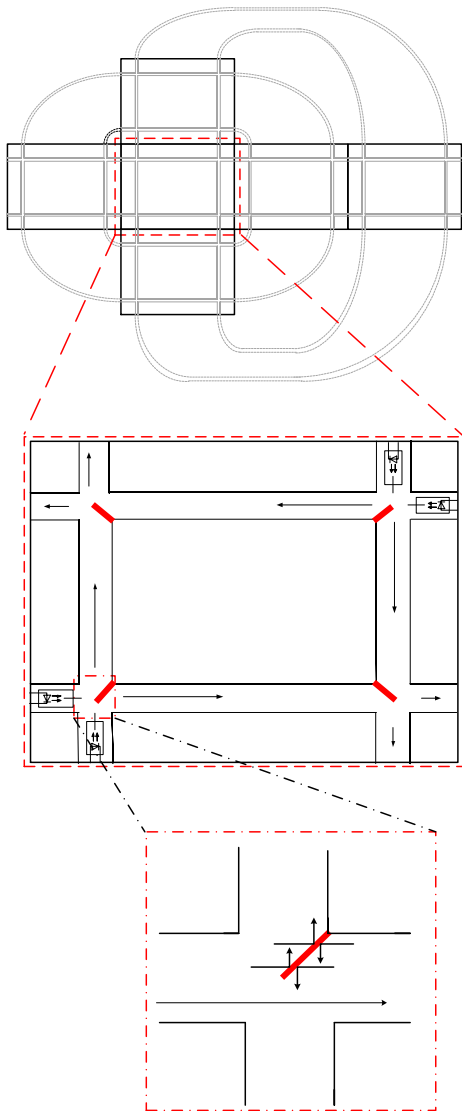

Fig. 2 Architecture of glass fiber based communication showing tiles

Many commercial LEDs and photodiodes were evaluated for our design requirement. The main parameter in selection of LED is the radiated emitter power in terms of light energy and the amount of current required to generate the desired light energy. The radiated optical power, P_o , is directly proportional to the amount of current flowing through LED, I_{LED} , given by (1).

$$P_o = \eta \cdot V \cdot I_{LED} \quad (1)$$

Where η is the optical efficiency of the LED. The theoretical expressions for calculation of transmit and receive optical power and some losses of glass fibre have been discussed in this section.

The transmitted optical light from the LED is not evenly distributed but distributed in the angular range. Fig 3 shows a typical graph of relative radiant intensity i.e. emitted power versus angular displacement for commercial LED, TSHG8400. It shows how directional the emitted light is. The narrower the radiation pattern, the more optical energy is concentrated in particular direction.

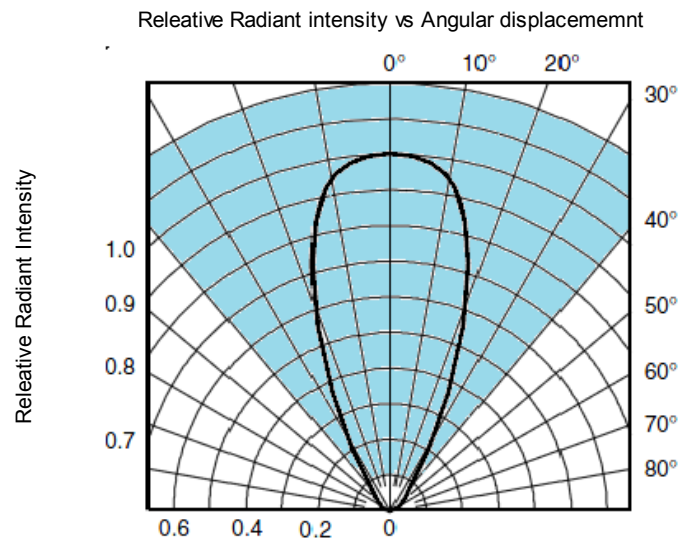

Fig.3 Relative Intensity vs Angular Displacement, courtesy Vishay [5]

The radiation pattern of typical LEDs depends upon the incident power. The beam angle for TSHG8400 is given by (2).

$$Beam\ angle = \frac{P_o}{60mW/Sr} \quad (2)$$

The radiation pattern of [5] for 50mW transmit power is 0.8Sr which corresponds to 30° radiant power intensity.

The radiant intensity is guided to the glass optical fibre by use of Snell's law. In order to interface the transmit maximum optical power to the glass fibre, law of refraction is used which relates the indices of refraction n of the two different media to the directions of propagation in terms of the angles to the normal given by (3).

$$\frac{\sin \theta_i}{\sin \theta_r} = \frac{n_1}{n_2} \quad (3)$$

Where θ_i is the angle of incidence and θ_r is the angle of reflectance. The angles are measured from the normal to the surface, at the point of contact, as shown in Fig 4. The constants n are the indices of refraction for the corresponding media one being air ($n_1=1$) and the other one glass ($n_2=1.5$).

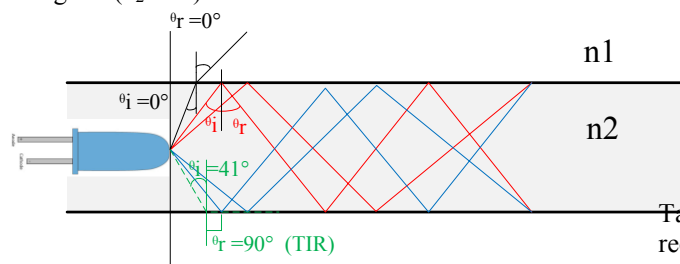

Fig. 4 Optical light guidance in the Fiber

The angle of incidence of light that make sure that all the optical light is guided inside the glass fibre is given by (4)

$$\theta_i = \sin^{-1} \frac{1}{n_2} \quad (4)$$

This expression gives critical angle for which the incident ray does not leave the glass fibre, namely when the angle of reflectance is 90°. Any incident angle greater than the critical angle is consequently reflected from the boundary instead of being refracted. Therefore using equation (4), we guarantee that any light ray of incident angle from 41° stays inside the glass and hence is received by the receiver. This angle is termed critical angle where total internal reflection (TIR) takes place. The shaded area in Fig 3 shows the light radiation guided inside the glass fibre as per above calculations. Fig 3 suggests that maximum light emitted by the LED is in between the -40° to 40° therefore most of the light is successfully reflected in the fiber with very small losses.

The received current depends on the input optical power and the responsivity of the photodiode at a certain wavelength. The theoretical expression for received current, $I_{received}$, is given by (5).

$$I_{received} = \frac{P_o}{4 * \phi^2} * A_{photo} * Responsivity \quad (5)$$

Where ϕ is the diameter of the glass fibre, A_{photo} is the active area of photodiode and responsivity of photodiode is given in (A/W). This received current has a high dynamic range depending upon the position of the receiver. A novel discrete receiver has been designed to amplify the received current. Fig 5 shows the photograph of glass with the guided optical light. Reflecting mirrors are not shown in this photograph.



Fig. 5 Photograph showing guided light propagation

Table I shows theoretical and measured values of received current for different values of input radiated optical power. The theoretical results are calculated for plexiglass of $\phi = 7.5mm$.

S.No	Radiated Power	Responsivity	Received current	Received current	Error
	Po(mW)	(A/W)	Theoretical (mA)	Measured (mA)	(%)
1	10	0.47	0.42	0.39	7.1
2	20	0.47	0.85	0.75	11.7
3	30	0.47	1.27	1.15	9.4
4	40	0.47	1.69	1.55	8.2

Table 1

III.II. RADIO FREQUENCY BASED COMMUNICATION SYSTEM

After much literature review, radio frequency communication system has been developed using TI CC2510 and CC1110 transceiver modules. The protocol stack has been kept compliant with propriety simpliciTI protocol. The receive signal strength for different variable power levels have been computed and plotted. The packet format for the receive packets has been detected using a commercial packet sniffer software and the received packets from different radio transceivers have been received with a very small packet error rate.

We are able to transmit packets with output transmit power as low as up to -30dBm with acceptable average RSSI. The testing was performed using commercial TI transceivers. The CC2510 and CC1110 provide a wireless solution for intra-satellite communication system.

The CC2510 is designed to offer a wireless communications at 2.4GHz, with a bit rate up to 500k Baud. In order to minimize the cost, CC2510 has a highly integrated 8051-compatible microcontroller and up to 32kB of in-system programmable flash memory.

SimpliciTI is a TI proprietary low-power RF network protocol. SimpliciTI has very low cost of memory; it only needs less than 8k flash memory and 1k ram space depend on configuration. It supports 2 basic topologies: strictly peer-to-peer and a star topology. The protocol support is realized in a small number of API calls. These APIs support customer application peer-to-peer messaging. The association between two applications, called linking, is done at run time.

SimpliciTI support sleep mode for the devices in order to extend the working time. The UML class diagram of implemented communication system using simpliciTI is shown in Fig. 6

The simpliciTI protocol stack was implemented for point to point communication testing inside the satellite. Fig.7 shows the transmitter sending a broadcast request for joining and consequently, the receiver device with the given destination address joining the network. The intra satellite communication was tested by placing the receivers at different locations w.r.t. receivers in certain CubeSat configurations and the receive signal strength was measured. Fig. 8 shows the measured RSSI for different power levels of transmitters.

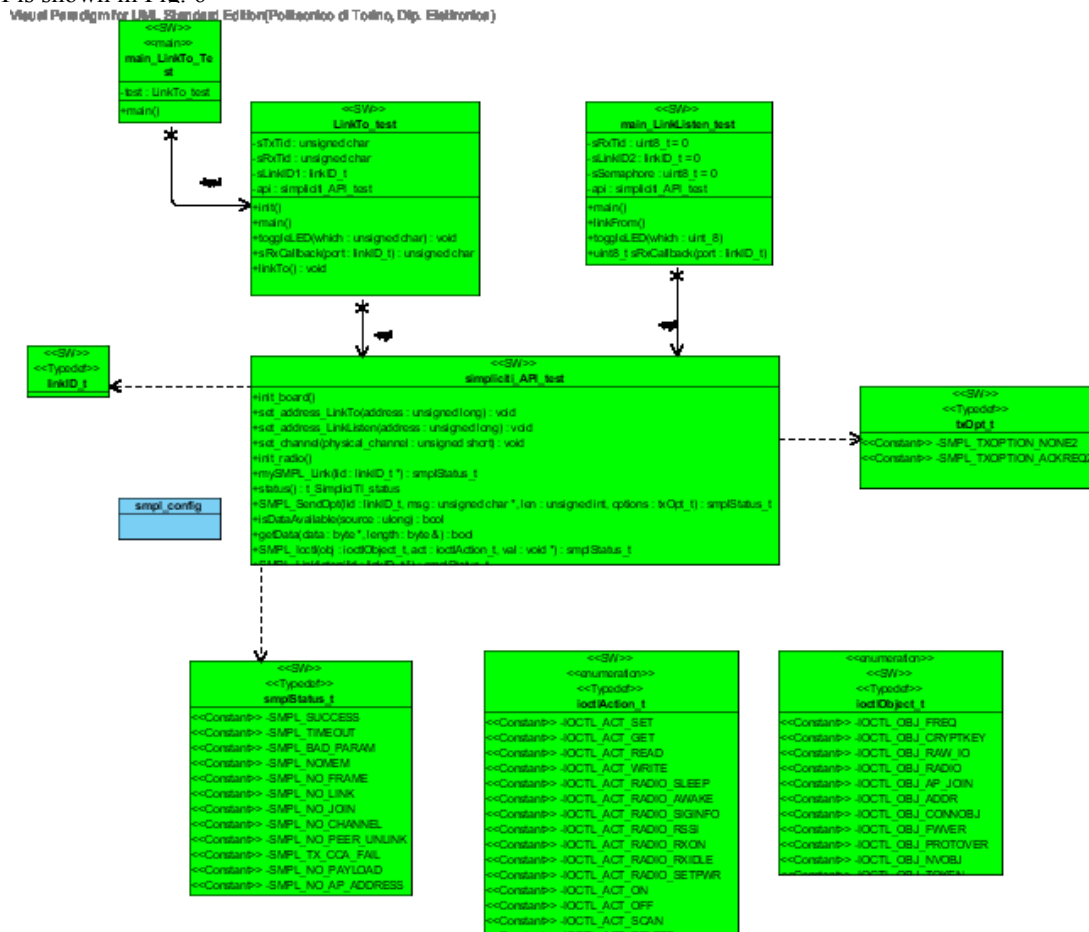

Fig.6. UML modelling of simpliciTI API

P.nbr.	Length	Dest. Address	Source Address	Transaction ID	Applicaton payload	Join	Request	TID	Token	Nbr. Conn.	Pro.Ver.	RSSI (dBm)	LQI	FCS	
1	19	FF FF FF FF	78 56 34 12	0x40	****	0x01	0x17	0x5060708	0x02	0x02		-12	19	OK	
P.nbr.	Length	Dest. Address	Source Address	Transaction ID	Applicaton payload	Link	Request	TID	Token	Local_Port	RX_Type	Pro.Ver.	RSSI (dBm)	LQI	FCS
2	20	FF FF FF FF	78 56 34 12	0x41	*****	0x01	0xA6	0x01020304	0x3D	CONT_LISTEN	0x02		-12	18	OK
P.nbr.	Length	Dest. Address	Source Address	Transaction ID	Applicaton payload	User Port	RSSI (dBm)	LQI	FCS						
1	19	78 56 34 21	78 56 34 12	0x49	****	0x20	-12	8	OK						
2	19	78 56 34 21	78 56 34 12	0x4A	****	0x20	-12	19	OK						
3	19	78 56 34 21	78 56 34 12	0x4B	****	0x20	-12	11	OK						
4	19	78 56 34 21	78 56 34 12	0x4C	****	0x20	-12	14	OK						
5	19	78 56 34 21	78 56 34 12	0x4D	****	0x20	-12	17	OK						
6	19	78 56 34 21	78 56 34 12	0x4E	****	0x20	-12	15	ERR						

Fig. 7 Data packet format for point to point communication

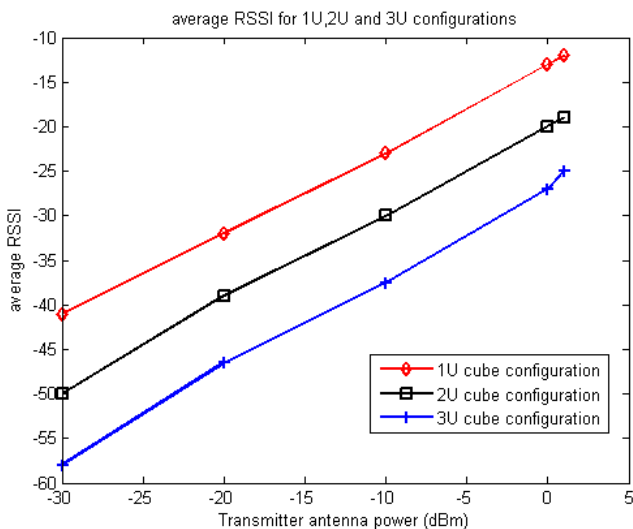

Fig. 8 average RSSI for certain transmit power levels

The initial result indicate that we can communicate across the tiles with as low as -30dbm transmit power which is very low as compared to the optical solution. Moreover, no line of sight is required to accomplish the communication across the tiles.

IV. CONCLUSION

In this paper we have shown different possible data communication solutions for small modular satellite including wired and wireless ones. The limited capacity of a processor has been overcome by proper design strategy to map certain protocols to use at given time. At the end, an analysis has been performed to choose between the communications systems.

REFERENCES

- [1] Stefano Speretta, Leonardo M. Reyneri, Claudio Sanso'e, Maurizio Tranchero, Claudio Passerone, Dante Del Corso., " Modular architecture for satellites," 58th International Astronautical Congress , Hyderabad, India, 24 - 28 September 2007.
- [2] Leonardo M. Reyneri, Danilo Roascio, Claudio Passerone, Stefano Iannone, Juan Carlos de los Rios, Giorgio Capovilla, Antonio Martínez-Álvarez and Jairo Alberto Hurtado (2012). Modularity and Reliability in Low Cost AOCSs, Advances in Spacecraft Systems and Orbit Determination, Rushi Ghadawala (Ed.), ISBN: 978-953-51-0380-6, InTech, Available from: <http://www.intechopen.com/books/advances-in-spacecraft-systems-and-orbit-determination/modularity-and-reliability-in-low-cost-aocs>
- [3] Leens, F.,; "An introduction to I²C and SPI protocols," Instrumentation & Measurement Magazine, IEEE , vol.12, no.1, pp.8-13, February 2009.
- [4] NXP Semiconductors, "I²C-bus specification and user manual, UM10204"NXP Semiconductors user manual 2007.

- [5] Mughal, M.R.; De Los Rios J.C.; Reyneri, L.M.; Ali, A., Scalable Plug and Play Tiles for Modular Nano Satellites, in: IAC-12,B4,7A,1,x13360, 63rd International Astronautical Congress, 1 – 5 October 2012, Naples, Italy.
- [6] T. Instruments, "MSP430 User's Guide," Texas Instruments, Tech. Rep.,SLAU208H, Dec 2010
- [7] Mughal, M.R.; Reyneri, L.M.; De Los Rios, J.C.; Ali, H., "Development of optical wireless transceiver for data communication in small satellites," *Satellite Telecommunications (ESTEL), 2012 IEEE First AESS European Conference on* , vol., no., pp.1,6, 2-5 Oct. 2012 doi: 10.1109/ESTEL.2012.6400102