

MEASURING GRAVITOMAGNETIC EFFECTS BY MEANS OF RING LASERS

Original

MEASURING GRAVITOMAGNETIC EFFECTS BY MEANS OF RING LASERS / Tartaglia, Angelo. - In:
INTERNATIONAL JOURNAL OF MODERN PHYSICS CONFERENCE SERIES. - ISSN 2010-1945. - STAMPA. -
23:(2013), pp. 125-134. (3rd Galileo–Xu Guangqi Meeting Beijing, China 11-15 ottobre 2011)
[10.1142/S2010194513011173].

Availability:

This version is available at: 11583/2521508 since:

Publisher:

World Scientific

Published

DOI:10.1142/S2010194513011173

Terms of use:

This article is made available under terms and conditions as specified in the corresponding bibliographic description in the repository

Publisher copyright

(Article begins on next page)

International Journal of Modern Physics: Conference Series
© World Scientific Publishing Company

Measuring gravitomagnetic effects by means of ring lasers

Angelo Tartaglia

*Dipartimento di Fisica, Politecnico, Corso Duca degli Abruzzi 24
Torino, 10129, Italy and INFN, Torino, Italy
angelo.tartaglia@polito.it*

Received Day Month Year

Revised Day Month Year

Light is a good probe for general relativistic effects. Exploiting the asymmetry of the propagation in the vicinity of a central rotating mass it is possible to use a ring laser in order to measure the frame dragging of the reference frames by the gravitational field of the Earth (Lense-Thirring effect). I shall present the G-GranSasso experiment whose objective is precisely to measure the Lense-Thirring and the de Sitter effects in a terrestrial laboratory. The experimental apparatus will be made of a set of at least three, differently oriented, ring lasers rigidly attached to a central "monument". The signal will be in the form of the beat frequency produced in the annular cavity of each laser by the rotational anisotropy. The laboratory will be located underground in the Laboratori Nazionali del Gran Sasso facility, in Italy. The required sensitivity is just one order of magnitude below the performance of the best existing instruments and the new design will attain it.

Keywords: Gravitomagnetism; Lense-Thirring; Ringlaser.

PACS numbers: 04.80.-y, 04.20.-q

1. Introduction

Among the effects foreseen by the classical General Relativity theory (GR) there are the ones due to the so called gravito-magnetic component of the gravitational interaction. According to GR a rotating mass interacts with nearby test gyroscopes superposing a Newtonian (first order approximation) attraction (the corresponding field is commonly called gravito-electric) to an action analogous to the one exerted by a big magnet on other small ones. The latter interaction is attributed to the gravito-magnetic field. Another way of describing this type of interaction is to say that the rotating central mass drags with itself the space-time as such; in practice a zero angular momentum freely falling object (radial free fall) would appear as rotating when seen from infinity. A possibly measurable effect of this type was identified as early as in 1918 and was named Lense-Thirring (LT) effect, after the names of its discoverers^{1 2}. From the start however it was immediately clear that LT was extremely weak in any reasonable situation so that it would have been very hard to reveal it. So far there have been only two measurements of the LT effect

2 *Angelo Tartaglia*

and one also knows that the data obtained from the observation of pulsars in binary systems are compatible with the presence of gravito-magnetic interactions. The first published result on the terrestrial LT effect is due to Ciufolini and collaborators ³. The drag effect was read out of a sophisticated analysis made on the data from the laser ranging of the orbits of two satellites (LAGEOS I and LAGEOS II) launched for other purposes: finally GR was confirmed with a 10% accuracy. The whole orbit of the satellite acts as a big gyroscope and its plane is dragged around by the rotating earth. A new experiment of the same type will use the dedicated satellite LARES, expected to fly in February 2012 ⁴. The other experiment on the LT effect was initially proposed at the end of the 50's of the 20th century independently by Pugh ⁵ and Schiff ⁶, then the idea was implemented during more than four decades by a NASA-Stanford University collaboration, being Francis Everitt the Principal Investigator. The Gravity Probe B (GP-B)^a satellite was launched on April 19 2004. On board it carried, besides a highly sophisticated control and measurement system, four spherical gyroscopes coated of a superconducting thin film. The relativistic effects were expected to be seen as precessions of the axes of the gyros. The data taking lasted approximately 12 months, then a long post flight calibration, data analysis and modeling of disturbances took place. Unfortunately an unexpected problem to one of the gyros could not be corrected ex-post, so finally LT was measured with a 19% accuracy, considerably less than the initial purpose ⁷.

Here I am presenting a recently proposed new experiment to test the terrestrial LT effect. Its name is G-GranSasso and the Principal Investigator is Angela Di Virgilio of the Pisa section of the Italian INFN. The proposal is presented by an international collaboration which is described in the appendix. The difference between G-GranSasso and the previous experiments is that instead of mechanical gyroscopes we intend to use light as a probe. The idea, which is described in the following, is based on the fact that the propagation of light in the gravitational field of a rotating mass is anisotropic: a given physical loop not containing the axis of rotation requires different times to be covered in the right- and in the left-handed senses. This tiny difference depends on various relativistic effects including LT. Our proposal is to use ring-lasers located in a terrestrial laboratory for measuring the above asymmetry and from that deduce the gravito-magnetic effects. The present sensitivity of the best existing ring laser for fundamental physics research ^b is approximately one order of magnitude above the threshold to be trespassed in order to measure LT; it is then reasonable to expect the right sensitivity to be attainable in a specially designed new instrument adopting the best technologies of the moment. In the next sections I shall describe both the principle and some practical aspects of G-GranSasso. Details may be found in ⁸.

^aThis is the name of the experiment

^bIt is G, located in Wettzell, Germany, and will be briefly described further on

2. Axially symmetric space-times

A steadily rotating mass is surrounded by a space-time endowed with an axial symmetry around a time-like axis. Choosing a reference frame centered on the body and polar space coordinates the general line element of such a space-time is:

$$ds^2 = g_{00}dt^2 + g_{rr}dr^2 + g_{\theta\theta}d\theta^2 + g_{\phi\phi}d\phi^2 + 2g_{0\phi}dtd\phi. \quad (1)$$

The elements of the metric tensor $g_{\mu\nu}$ do not depend on ϕ and on t .

The term relevant for our interest here is the mixed one $g_{0\phi}$. In a general situation and with Cartesian coordinates we would have three such terms mixing time with the space coordinates. If the source is in uniform translational motion with respect to the observer all mixed terms can be canceled by means of an appropriate global coordinate transformation. This is not the case when we have to do with rotations and this fact tells us that rotating sources do produce peculiar physical phenomena.

In general the three mixed terms may be read as the components of a three-vector:

$$\mathbf{h} = \{g_{0i}\}, \quad i = \{1, 2, 3\}. \quad (2)$$

With our choice of reference frame and coordinates only $g_{0\phi} \neq 0$. By analogy with electromagnetism the curl of the three-vector \mathbf{h} is called the gravito-magnetic field of the source:

$$\nabla \wedge \mathbf{h} = \mathbf{B}_g. \quad (3)$$

In the case of a steadily rotating source the gravitomagnetic field in empty space has a dipolar structure:

$$\mathbf{B} = \frac{2G}{c^2 r^3} [\mathbf{J} - 3(\mathbf{J} \cdot \mathbf{u}_r)\mathbf{u}_r] \quad (4)$$

G is Newton's gravitational constant, \mathbf{J} is the angular momentum of the source, \mathbf{u}_r is a radial unit three-vector.

3. Light in a gravitomagnetic field

Let us consider a spacely closed loop along which two counter-propagating light beams are moving (see Fig. 1). Of course to that purpose mirrors will have to be used.

Starting from (1) equated to 0 we may extract the coordinated time interval dt , then integrate along the loop in order to obtain the total time of flight. It is easily seen that two solutions exist according to the sense along the loop. All in all the difference between the lefthanded (same sense as the rotation of the source) and the righthanded times of flight turns out to be:

$$\delta T = -2 \oint \frac{g_{0\phi}}{g_{00}} d\phi. \quad (5)$$

3.1. A ring laser

The practical implementation of a loop of light beams like the one described in the previous section is a ring laser. An example may be seen in the sketch shown in Fig. 2. From an active laser cavity two beams are emitted in opposite directions. Each beam comes back to the cavity after reflections on the mirrors placed at the corners of a polygon. The whole circuit forms a resonant loop and in stationary condition two standing electromagnetic waves are established with opposite handedness. Each standing wave consists of an integer number of wavelengths; if the working condition is single mode the integer number of wavelengths is the same for both right and left circulation, but the frequencies of the two waves are slightly different because of the difference in the times of flight along the loop. The super-

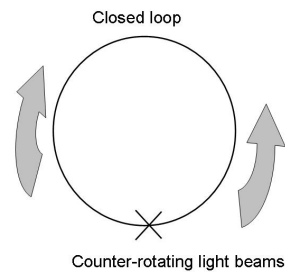

Fig. 1. A closed loop along which two light beams travel in opposite directions originating two superposed standing waves. In a gravitomagnetic field the frequencies of the two standing waves will be different.

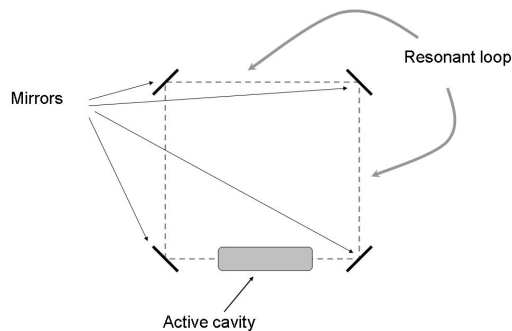

Fig. 2. A square ring laser is made of an active cavity and four mirrors. The whole thing forms a resonant loop in which righthanded and lefthanded standing waves are established.

position of the two standing waves at different frequencies gives rise to a beat whose frequency f_b is easily written in terms of the time difference (5), the geometry of the loop and the wavelength of the laser:

$$f_b = \frac{f_+ - f_-}{2} = \frac{c^2}{\lambda P} \delta T. \quad (6)$$

P is the physical length of the loop; the subscript + means lefthanded, the subscript – stands for righthanded. The beat can be extracted at one of the corners of the resonant loop and its frequency measured. This is indeed the way a ring laser works.

3.2. The expected signal

In order to find the signal that could be measured from a ring laser in a ground laboratory we must convert the formulae used so far to local laboratory coordinates. First of all the involved time will be the proper time in the laboratory so that Eq. 5 becomes:

$$\delta T_{lab} = -2\sqrt{g_{00}} \oint \frac{g_{0\phi}}{g_{00}} d\phi|_{lab}. \quad (7)$$

We can still use polar coordinates centered on the earth, but we have to move to the non-inertial worldline of a laboratory fixed to the surface of the planet. Furthermore we will express the gravitational field in Post-Newtonian approximation up to the first meaningful terms in the moment of inertia I_{\oplus} . After the consequent manipulations we see that:

$$g_{0\phi} \simeq (2\frac{j}{r} - r^2\frac{\omega}{c} - 2\mu r\frac{\Omega_{\oplus}}{c}) \sin^2 \theta \quad (8)$$

$$g_{00} \simeq 1 - 2\frac{\mu}{r} - \frac{\omega^2 r^2}{c^2} \sin^2 \theta$$

In Eq.s 8 two abbreviations have been used:

$$\mu = G\frac{M_{\oplus}}{c^2} \approx 4.4 \times 10^{-3} m \quad (9)$$

$$j = G\frac{J_{\oplus}}{c^3} = G\frac{\Omega_{\oplus} I_{\oplus}}{c^3} \approx 1.75 \times 10^{-2} m^2$$

The numbers give an idea of the orders of magnitude in the case of the earth. The angular velocity of the planet is Ω_{\oplus} ; ω is the absolute angular velocity (rotation with respect to the "fixed stars") of the instrument; if the device is fixed to the crust of the earth $\omega = \Omega_{\oplus}$.

Using Eq.s 7 and 8 and keeping terms up to the first order in j we obtain:

$$\delta f = f_+ - f_- = 4\frac{A}{\lambda P} \Omega_{\oplus} [\cos(\theta + \alpha) - 2\frac{\mu}{R} \sin \theta \sin \alpha + \frac{GI_{\oplus}}{c^2 R^3} (2 \cos \theta \cos \alpha + \sin \theta \sin \alpha)] \quad (10)$$

The ring laser has been assumed to be contained in a plane; A is the area contoured by the light beams; for simplicity the perpendicular to the plane of the loop has been assumed to lay in the meridian plane; α is the angle between the local radial direction and the perpendicular to the loop; θ is the colatitude of the site.

6 *Angelo Tartaglia*

Eq. 10 may be recast in vector notation as:

$$\delta f = 4 \frac{A}{\lambda P} [\boldsymbol{\Omega}_{\oplus} - 2 \frac{\mu}{R} \Omega_{\oplus} \sin \theta \hat{\mathbf{u}}_{\theta} + \frac{G J_{\oplus}}{c^2 R^3} (2 \cos \theta \hat{\mathbf{u}}_R + \sin \theta \hat{\mathbf{u}}_{\theta})] \cdot \hat{\mathbf{u}}_n \quad (11)$$

$\hat{\mathbf{u}}_n$ is the unit vector along the normal to the plane of the ring; $\hat{\mathbf{u}}_R$ is the radial unit vector; $\hat{\mathbf{u}}_{\theta}$ is the unit vector along the local meridian (towards increasing colatitudes); R is the radius of the earth or, to say better, the radial distance of the laboratory from the center of the earth.

In practice we recognize that the expected beat frequency is given by the product of a scale factor $S = 4 \frac{A}{\lambda P}$ times the projection onto the normal to the ring of a vector made of three terms, having the dimensions of angular velocities. The first one, which is the angular velocity of the earth $\boldsymbol{\Omega}_{\oplus}$, does not contain any reference to the mass or the angular momentum of the earth and gives rise to the purely kinematical Sagnac effect; the second term, $\boldsymbol{\Omega}_G = -2 \frac{\mu}{R} \Omega_{\oplus} \sin \theta \hat{\mathbf{u}}_{\theta}$, has various names (Schiff term, de Sitter term, geodetic term) and represents a relativistic effect due to the coupling of the rotation of the instrument with the gravito-electric or Newtonian potential; the last term, $\boldsymbol{\Omega}_B = \frac{G J_{\oplus}}{c^2 R^3} (2 \cos \theta \hat{\mathbf{u}}_R + \sin \theta \hat{\mathbf{u}}_{\theta})$, contains the coupling to the angular momentum of the earth and can properly be qualified as gravitomagnetic contribution or Lense-Thirring term.

Considering the orders of magnitude we see that:

$$\begin{aligned} \Omega_{\oplus} &\simeq 7.2 \times 10^{-5} \text{ s}^{-1} \\ \Omega_G \sim \Omega_B &\approx 10^{-9} \times \Omega_{\oplus} \approx 10^{-13} \text{ s}^{-1} \end{aligned} \quad (12)$$

These numbers set the goal to be attained in order to measure the properly general relativistic effects, i.e. the $\boldsymbol{\Omega}_G$ and $\boldsymbol{\Omega}_B$ "precession rates".

4. Existing instruments

Actual ring lasers exist in various sizes and for different purposes. In general these instruments are good rotation sensors. A practical application is precisely to replace mechanical gyroscopes in order to measure angular velocities of planes and other vehicles. The commercial device in these cases has more or less the size of a hand and the loop is realized by means of a coil of optical fiber. The scale factor S on which the sensitivity of the gyrolaser depends is proportional to the area of the loop and the latter is increased as much as possible increasing the number of windings of the coil. Coming to the instruments for research purposes I quote three examples. One is called G-Pisa, was developed as a rotation sensor to be used at the Virgo site and is now located in a laboratory of the Italian INFN in San Piero a Grado near Pisa. It is a square with a side of 1.35 m length, mounted on a granite table (see Fig. 3); the active element is a He-Ne laser; the sensitivity is in the order of 10^{-9} rad/s/ \sqrt{Hz} . G-Pisa will be used as a technology and measurement techniques testing apparatus in view of the coming G-GranSasso.

Another set of high sensitivity ringlasers has been built at the Cashmere Cavern site near Christchurch in New Zealand, by the Westminster University. Some de-

vices arrived up to a side of 20 m; the corresponding high value of the scale factor was however partly compensated by mechanical instabilities due to the length and reduced rigidity of the configuration.

The best research ringlaser of the moment is G located in the Geodätisches Observatorium Wettzell, in Bavaria. It is a square loop with a side 4 m long, fixed to a zerodur support (see Fig. 4), in order to minimize the effects of mechanical deformations and thermal drift. The laboratory is built under an artificial mound and is isolated from the surrounding environment, in order to eliminate the influence of the changes in air pressure and temperature, surface mechanical noise, wind pressure, etc. The sensitivity of G is $4.5 \times 10^{-12} \text{ rad/s}/\sqrt{\text{Hz}}$.

The ring lasers in Wettzell and in Christchurch are mostly devoted to precision geophysics and geodesy experiments. Fig. 5 shows an example of the signal from G, after subtraction of known geophysical contributions and disturbances. The values are in Hz; the bulk value corresponds to the Sagnac frequency of the earth, Ω_S ; the peaks represent the diurnal polar motion of the axis of the earth. The sensitivity is in the order of $10^{-8} \div 10^{-9}$ of the Sagnac signal, i.e. within one order of magnitude of what would be needed to see the general relativistic contributions.

5. G-GranSasso

The proposal named G-GranSasso is to build a set of ring lasers (not less than three) in a three-dimensional array, with a high enough sensitivity to reveal the general

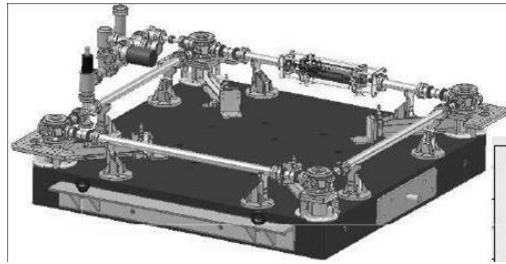

Fig. 3. The G-Pisa ring laser mounted on a granite table; the side is 1.35 m long.

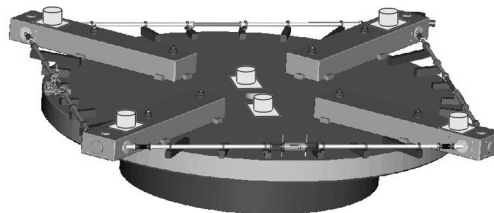

Fig. 4. The G ring laser in Wettzell on its zerodur support; the side is 4 m long, the laser power is 20 nW.

8 *Angelo Tartaglia*

relativistic contributions and especially the LT effect. Two possible configurations are under analysis, as seen in Fig. 6. The three-dimensional array is due to the fact that the quantities to be measured are indeed three-vectors, furthermore the geodetic term, Ω_G , and the gravitomagnetic term Ω_B have different orientations in space with respect to the Sagnac term. The experimental apparatus consists essentially of lasers and mirrors attached to a rigid support (the "monument"). In the case of the cube the ring lasers would be six, with a redundancy factor 2; the octahedral configuration has only three loops but lends the possibility to better control the geometry using resonating cavities (Fabry-Perot interferometers) along the main diagonals.

In any case the side of the square loops would be 6 m long, giving a scale factor S 50% higher than for G; the power of the laser should be 200 nW; the quality factor of the resonating cavities would be $Q = 3 \times 10^{12}$. The whole instrument would

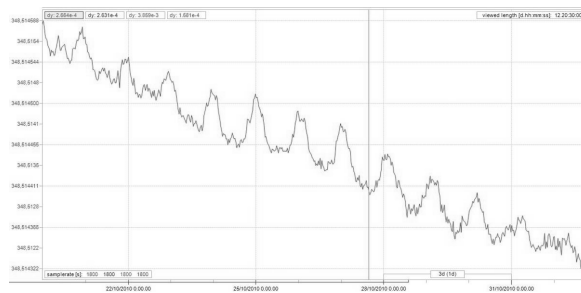

Fig. 5. Frequency reading of G, after subtraction of the main geophysical contributions. The time span is a couple of weeks. The frequency decrease with time is due to a thermal drift ($\sim 1 \times 10^{-8}$ /day). The bulk frequency, 348.51445 Hz, is the Sagnac signal of the earth; the peaks are due to the diurnal polar motion of the terrestrial axis, with an amplitude of the order of 50×10^{-6} Hz.

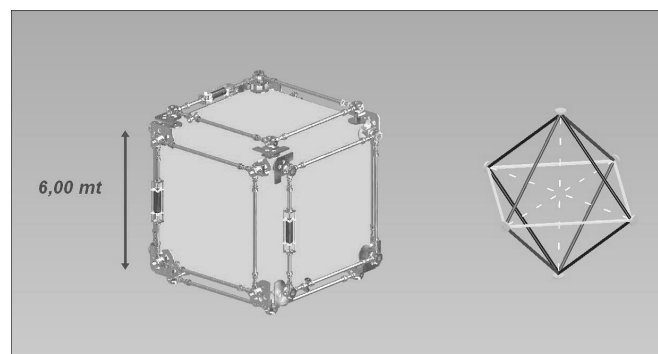

Fig. 6. Two possible choices for the configuration of G-GranSasso. On the left one has a cubic monument carrying six gyrolasers with a factor 2 redundancy; on the right an octahedral array is shown.

be located deeply under ground in the Gran Sasso National Laboratories in Italy; the reason of the underground laboratory choice is the screening from the surface mechanical noise. The objective is to measure the general relativistic "precession" with an accuracy of the order of $\sim 1\%$.

First analyzes and evaluations show that the LT effect could be revealed with the desired accuracy after several months long integration time ⁸.

6. Conclusion

I have presented the proposal of a new experiment named G-GranSasso aimed at measuring the geodetic and the Lense-Thirring precessions, due to the rotational part of the gravitational field of the earth, in a terrestrial laboratory. The probe to be used for the purpose is light and the measuring device is a three-dimensional array of ring lasers. The sought for precessions correspond to signals in the ring-laser approximately 10^{-9} times the kinematical Sagnac term due to the rotation of the planet, but with peculiar orientations in space, differing from each other and from the one of the Sagnac precession. The existing best technologies in ring laser rotation sensing, which correspond to the G instrument located in Wettzell, allow for sensitivities within more or less one order of magnitude from the figures needed for the purpose of the new experiment. A new apparatus, specifically designed for the purpose and built at the top of the available technologies in the next few years, is expected to be able to reveal the general relativistic rotation effects of the gravitational field of the earth with an accuracy in the order of 1% with integration times of months. In order to minimize all disturbances coming from the noisy surface of the planet, the new laboratory is planned underground, most likely at the "Laboratori Nazionali del Gran Sasso" facility in Italy. The proposal is putting together the best existing expertise in the field, being based on a collaboration between various Italian groups and Ulrich Schreiber's group in Munich (responsible of G in Wettzell), and being in correspondence with Jon Paul Wells's team in Christchurch (see in the Appendix the list of people contributing to the present proposal). G-GranSasso has been approved and supported for Research and Development activity by the Italian INFN and is under consideration for technology tests and implementation, then finally for the actual building of the laboratory. An independent measurement of the LT effect realized on earth in parallel to the new LARES mission in space and using light instead of mechanical gyroscopes will represent an important complement to the traditional approach to the sensing of gravito-magnetic effects. Last but not least, a terrestrial experiment based on the ring lasers technology is far less expensive than the experiments in space.

Appendix A. The collaboration

People so far contributing to the G-GranSasso proposal have been:

- F. Bosi, G. Cella, A. Di Virgilio from the INFN-Pisa, Italy

10 *Angelo Tartaglia*

- M Allegrini, J. Belfi, N. Beverini, G. Carelli, I. Ferrante, A. Fioretti, E. Maccioni, F. Stefani from the University of Pisa and CNISM, Italy
- F. Sorrentino from the University of Florence, Italy
- A. Porzio and S. Solimeno from the University of Naples Federico II and CNISM, Italy
- M. Cerdonio, A. Ortolan, J. P. Zendri from the University of Padua and INFN-LNL, Italy
- M.L. Ruggiero and A. Tartaglia from Politecnico di Torino and INFN-Torino, Italy
- Ulrich Schreiber and collaborators from the Technische Universität München- Fundamentalstation Wettzell and Forschungseinrichtung Satellitengeodäsie , Germany
- Jon-Paul Wells and collaborators from the University of Canterbury, Christchurch, New Zealand

References

1. J. Lense, H. Thirring, *Phys. Z.* **19**, 156-163 (1918)
2. H. Thirring, *Phys. Z.* **19**, 33 (1918)
3. I. Ciufolini, E. Pavlis, *Nature* **431**, 958 (2004); I. Ciufolini et al., *Space Sci Rev* **148**, 71-104 (2009).
4. I. Ciufolini, *Class. Quantum Grav.* **17**, 2369 (2000).
5. G. E. Pugh, *WSEG Research Memo* **11** (1959), reprinted in *Nonlinear Gravitodynamics, The Lense Thirring Effect, a documentary introduction to current research*, Editors R. Ruffini and C. Sigismondi, (World Scientific Pub., Singapore, 2002).
6. L. I. Schiff, *Phys. Rev. Lett.* **4**, 215 (1960).
7. C.W.F. Everitt *et al.*, *Phys. Rev. Lett.* **106**, 221101 (2011).
8. F. Bosi *et al.*, *Phys. Rev. D* **84**, 122002 (2011).