

Redundant hydraulic secondary flight control systems behavior in failure conditions

Original

Redundant hydraulic secondary flight control systems behavior in failure conditions / Borello, Lorenzo; Villero, Giuseppe; DALLA VEDOVA, MATTEO DAVIDE LORENZO. - In: JOURNAL OF MECHANICS ENGINEERING AND AUTOMATION. - ISSN 2159-5275. - 03:08(2013), pp. 499-506.

Availability:

This version is available at: 11583/2518939 since:

Publisher:

David Publishing Company

Published

DOI:

Terms of use:

This article is made available under terms and conditions as specified in the corresponding bibliographic description in the repository

Publisher copyright

(Article begins on next page)

Redundant Hydraulic Secondary Flight Control Systems Behavior in Failure Conditions

Lorenzo Borello, Giuseppe Villero and Matteo Davide Lorenzo Dalla Vedova

Department of Mechanical and Aerospace Engineering, Politecnico di Torino, Torino 10129, Italy

Received: February 10, 2013 / Accepted: March 12, 2013 / Published: August 25, 2013.

Abstract: The flight control systems, designed in order to assure the necessary safety level even in failure conditions, are generally characterized by a proper redundant layout. The redundancies must be designed in order to assure an adequate system behavior when some failures are present; in fact an incorrect layout may cause serious shortcomings concerning the response when some component is not operational. Therefore the usual correct design activities request the complete analysis of the system behavior in failure condition. The work analyses the response of a redundant secondary flight control hydraulic servo-mechanism equipped with some proper equalization devices, when some of the most probable and representative failures are present. It must be noted that the redundancy layout, designed in order to assure the necessary safety level even in failure conditions, may behave improperly during normal operations, if the system architecture is unsuitable, when manufacturing defects are present. The improper behavior, generally consisting of force fighting or speed fighting caused by different offsets or asymmetries between the two sections of the system, may be usually overcome by means of a suitable equalization device. Therefore, the system behavior during and following the failure transient greatly depends on both its redundancy architecture and related equalization device. The above mentioned problems have been studied by means of an appropriate physical-mathematical model of a typical electro-hydraulic servo-mechanism prepared to the purpose, performing a certain number of simulations of representative actuations in which different types of failures are accurately modeled. In the opinion of the authors, this paper concerns a topic quite neglected but important in the technical literature. At the best of the authors' knowledge, no specific scientific work in this field is available, excepting some industrial technical reports.

Key words: Flap controls, redundancy, dynamic simulation, failure.

Nomenclature

Cil	Hydraulic motor displacement (each) (m^3)	GP	Valve pressure gain (Pa/m)
CM	Motor viscous damping coefficient (each) ($N \cdot s/rad$)	GPS1, 2	Valves 1, 2 secant pressure gain (Pa/m)
Com	Command (rad)	GQ	Valve flow gain (m^2/s)
Cor1, 2	Valves 1, 2 input electric current (A)	GS	Speed loop gain (A/rad/s)
CorM	Cor max absolute value (A)	GV	Global control valve position gain (m/A)
D2ThM	Hydraulic motors acceleration (torque sum) (rad/s^2)	JM	Hydraulic motor and connected elements mass (each) ($kg \cdot m^2$)
DeCor	Equalization differential current (A)	Offset1, 2	Valves 1, 2 offset equivalent current (A)
DePC1, 2	Valves 1, 2 commanded pressure (Pa)	QM1, 2	Flow through hydraulic motors 1, 2 (m^3/s)
DePHS	Supply max differential pressure (Pa)	ThM	Hydraulic motors angular position (torque sum) (rad)
DThM	Hydraulic motors angular rate (torque sum) (rad/s)	ThS	Moving surface position (rad)
Err	Position error (rad)	TR	Load acting on the moving surface (N)
GC	Proportional gain of the position loop and servovalv amplifier (A/rad)	XS1, 2	Valves 1, 2 second stage position (m)
Geq _{ap}	Pressure equalization device static gain (A/Pa)	XSM	Max XS value (m)
Geq _{xs}	Valve position equalization device static gain (A/m)	ZM	Surface/motor gear ratio
		τ	Equalization device time constant

Corresponding author: Matteo Davide Lorenzo Dalla Vedova, Ph.D., research assistant, research fields: applied mechanics, onboard systems, servomechanism, prognostics, and numerical simulation. E-mail: matteo.dallavedova@polito.it

1. Introduction and Aims of Work

The flight control systems may be affected by several types of failures according to their specific layout. Generally each failure may produce an

operational condition involving some safety criticality. As a consequence, in order to assure the necessary safety level in failure conditions, the flight controls must be conceived according to an appropriately redundant design. Indeed the system must operate even when one or more failures occur with no or partial loss of performance and dynamic qualities. It must be noted that failures can be of the passive or active type. In the former case, the remaining portion of the servo-mechanism does not lose its operability, in the latter case the situation is opposite. Therefore, while the passive failures do not need specific corrective actions, the active ones must be detected by an appropriate monitoring device able to shut off the failed hydraulic unit. It must be pointed out that, when manufacturing defects are present without any type of failure, the redundancy may produce some improper behavior not caused by a single component failure, but only due to an unsuitable system design concerning the redundancy architecture, generally falling into two categories, torque-summed and speed-summed systems. In particular, the present work concerns a typical electro-hydraulic torque-summed redundant servo-mechanism in which the servovalve is generally considered the most critical element, as a consequence of its complex architecture. The abovementioned defects generally consist of asymmetrical overlap of the servovalve control passageways, asymmetrical geometry of the feedback spring or of the first stage spring, undesired magnetic field in the first stage torque motor, etc. All these defects develop effects considered as “null position servovalve errors” and are generally modeled as an offset current affecting the input of the servovalve coils. Different offsets or asymmetries between the two sections of the system may cause the above mentioned improper behavior, generally consisting of force fighting (speed fighting for speed-summed systems), which may be usually overcome by means of a suitable equalization device.

This work analyses the response of the abovementioned servo-mechanism equipped with some proper equalization devices when some failure modes are present. According to the servovalve arrangement (flapper-nozzle or jet-pipe), the examined failure modes are

- (1) torque-motor coil interruption (flapper-nozzle and jet-pipe);
- (2) first stage filter contamination (flapper-nozzle and jet-pipe);
- (3) jet pipe contamination (jet-pipe);
- (4) spool seizure in centered position (flapper-nozzle and jet-pipe);
- (5) electrical connections disengagement (flapper-nozzle and jet-pipe);
- (6) fixed orifices or nozzles contamination (flapper-nozzle);
- (7) spool seizure in maximum displacement (flapper-nozzle and jet-pipe);
- (8) electrical amplifier polarization (flapper-nozzle and jet-pipe).

The failure modes above listed as numbers (1) to (5) give rise to a failure behavior known as “null position failure” because their consequence is the inability to perform and maintain any spool displacement from the centered position; the failure modes above listed as numbers (6) to (8) give rise to a failure behavior known as “hard-over failure” in which the spool reaches one of its ends of travel as a consequence of a control lack. The system behavior during and following the failure transient greatly depends on its redundancy architecture and related equalization device. In fact, the behavior following the failure is particularly dependent on the conception and the software characterizing the equalization device. The present work studies the most commonly used architecture, based on the torque-sum arrangement (Fig. 1). In this case, the torques developed by both the hydraulic motors are summed within the gear reducer connecting the power drive unit with the motion transmission.

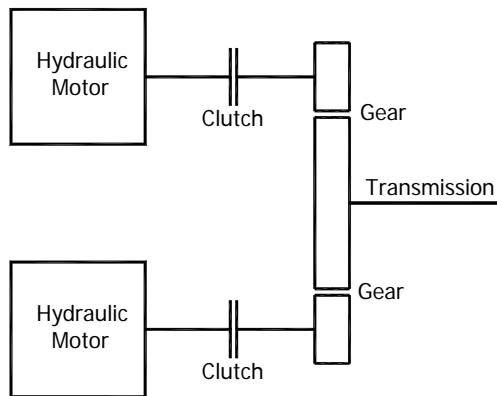

Fig. 1 Torque sum.

Two types of equalization devices are proper to this mechanical arrangement, being based on the following criteria: the former aims to reduce the difference between the differential pressure produced by each servovalve on its coupled hydraulic motor, the latter aims to reduce the difference between the spool displacements of the servovalves itself. In order to evaluate the effects of the failure modes, a physical-mathematical model of the servo-mechanism has been developed, equipped with electro-hydraulic

servovalve, hydraulic motor, position feedback and equalization control law; from this, a computer program has been obtained, by means of which several simulations of the system behavior under different failure mode conditions have been performed.

The paper is organized as follows: Section 2 describes the physical-mathematical models of the considered servo-mechanism; Section 3 illustrates the system behavior analysis; and Section 4 shows the conclusions.

2. Physical-Mathematical Models of a Typical Servo-Mechanism

Figs. 2 and 3 represent the block diagrams employed for the servo-mechanism representation in the above mentioned configurations:

- torque sum, differential pressure equalization (Fig. 2);
- -torque sum, spool displacement equalization (Fig. 3).

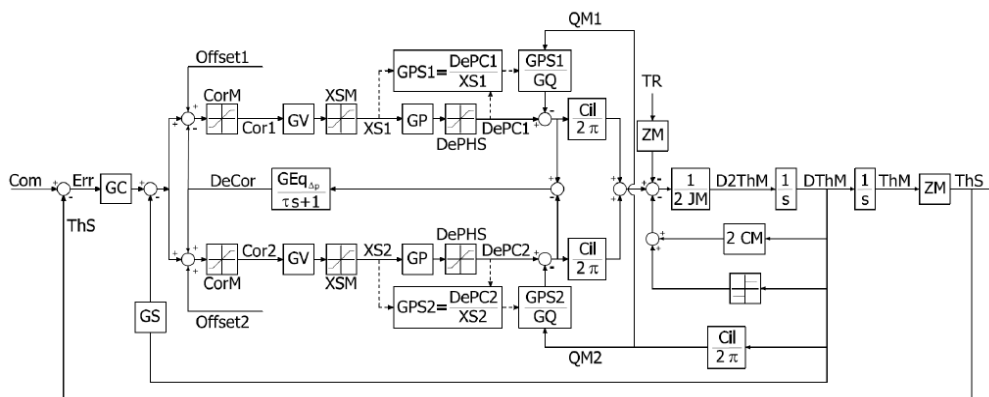

Fig. 2 Block diagram of a torque summed system with differential pressure equalization.

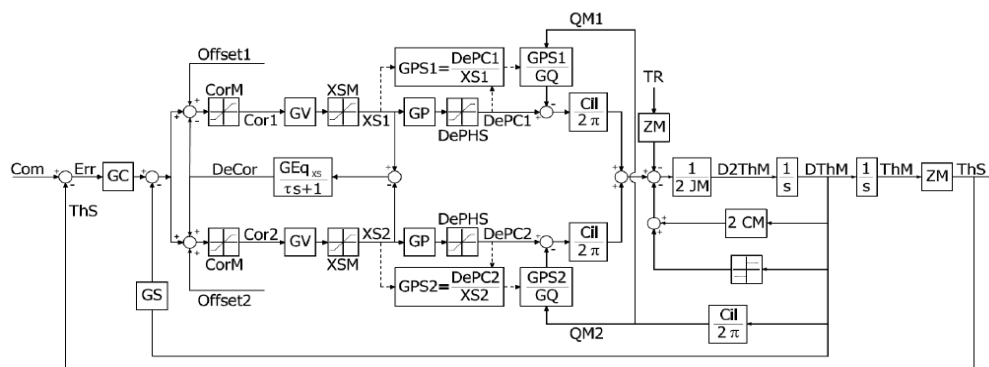

Fig. 3 Block diagram of a torque summed system with spool displacement equalization.

As the figures show, in every system layout, the “error” (Err) arising from the comparison between the commanded (Com) and actual (ThS) positions is computed by means of a proportional position control law (GC) equipped with angular rate loop (GS) in order to obtain the drive current (Cor—saturated CorM) in input to each of the two servovalves; all its manufacturing defects are contained in the “Offset” quantity summed to the drive current and to the equalization current (DeCor) arising from the equalization device. From the resulting current, by means of a model characterized by an instantaneous dynamics (GV), the positions of the valves spools (XS—end of travel XSM) are computed [1]. From these, by means of the valve pressure gain (GP—corrected in order to take into account the effects of the saturation on the differential pressure GPS), the differential pressures (DePM) effectively acting on the motors are obtained (taking into account the pressure losses caused, within the valve passageways, by the flows through the hydraulic motors QM and related to the valve flow gain GQ) [2].

The assumption of the constant dynamics represented by GV is sufficiently realistic because the incorrect behaviors caused by the manufacturing defects are characterized by slow dynamics. Therefore, the use of a more detailed model of the servovalve (characterized by high dynamics) produces no further significant results. In the considered torque sum case the differential pressures, by means of the motor displacements (Cil) and the total moment of inertia of the surface-motors assembly (2 JM), taking into account the total load (TR), the viscous (coefficient CM) and dry friction torques [3], give the assembly acceleration (D2ThM); its integration gives the speed (DThM), affecting the viscous and dry frictions and the motor working flows. The last, summed to the leakage ones, give the above mentioned pressure losses through the valve passageways. The speed integration gives the actual motor position (ThM) and, by the gear ratio (ZM), the position of the moving surface

(ThS—controlled element) which is reported in feedback on the command comparison element.

It must be noted that the optimization of the design parameters is not the specific target of the work. However, the component dataset (servovalve, hydraulic motor, etc.) is assumed according to the characteristics of some actual components made by important firms operating in this field.

Furthermore, the values of the gains adopted in the control (simple but sufficient to the purpose) and equalization laws are settled by means of parametrical analysis, more suitable when the simulation model involves specific mechanical non linearities as dry friction, end of travel, etc.

3. System Behavior Analysis

According to the above mentioned mathematical models, two dynamic simulation programs have been prepared in order to evaluate the system behavior in the different configurations (differential pressure equalization and spool displacement equalization) and operating conditions.

As shown in Figs. 2 and 3, the equalization control laws are considered as proportional type developing a supplementary current proportional to the difference between the two differential pressures (differential pressure equalization) or the two spool displacements (spool displacement equalization).

Figs. 4-10 are referred to a system having an input step command raising from 0 to 0.1 rad in which the failure event occurs at time $t = 0.02$ s and regards only the subsystem 1, retaining the full operability of the subsystem 2.

Figs. 4-7 are referred to a system affected by a null position failure without any type of equalization device (Fig. 4), with a differential pressure (Figs. 5 and 6) or spool position (Fig. 7) equalization device.

Analyzing Fig. 4 it can be noted that when the failure occurs, the valve of the subsystem 1 suddenly returns to the centered position, so performing a strong damping action. On the contrary, the valve of the

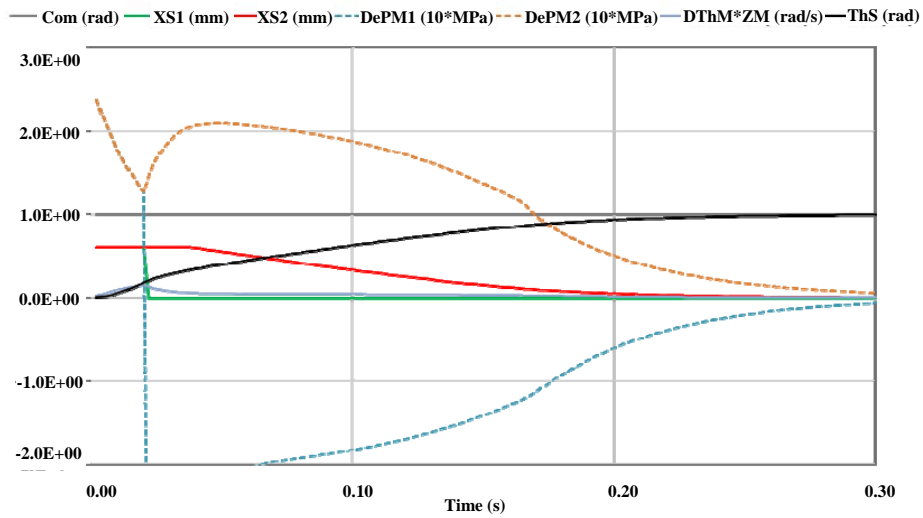

Fig. 4 System affected by a null position failure without any type of equalization device.

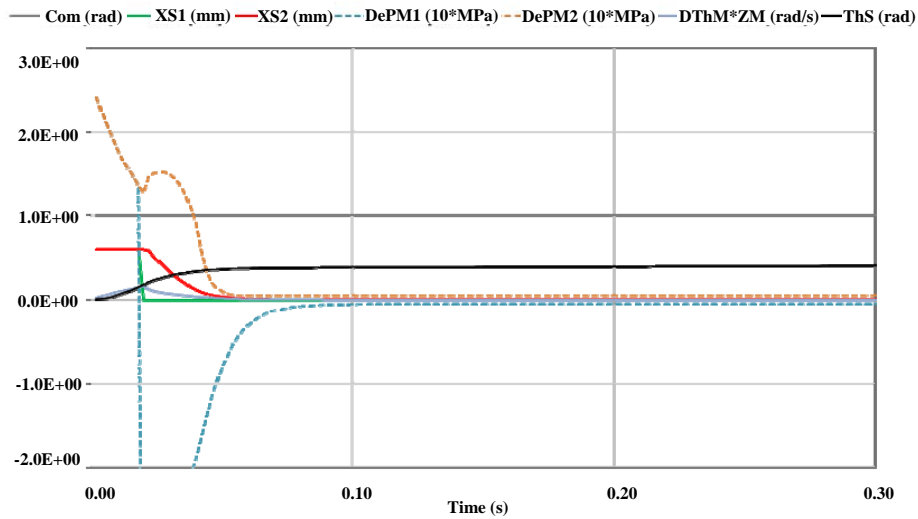

Fig. 5 System affected by a null position failure with differential pressure equalization device.

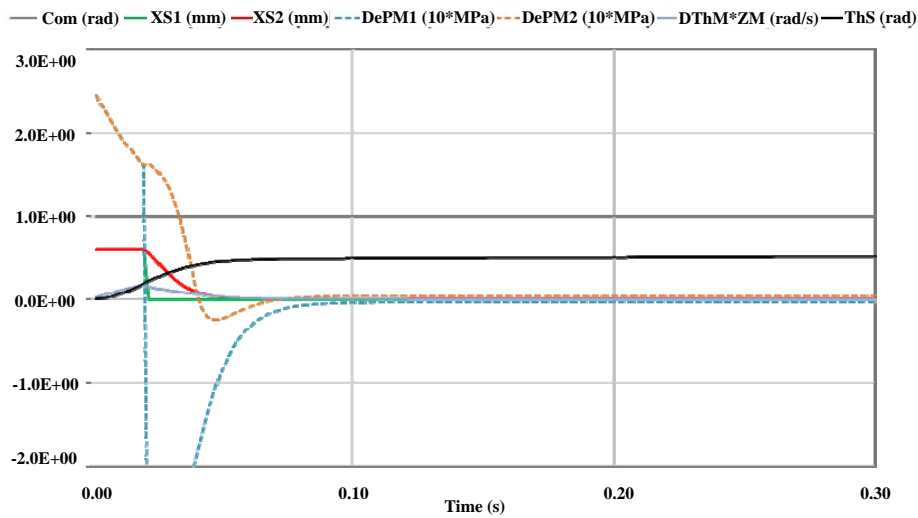

Fig. 6 System affected by a null position failure with differential pressure equalization device (increased GQ).

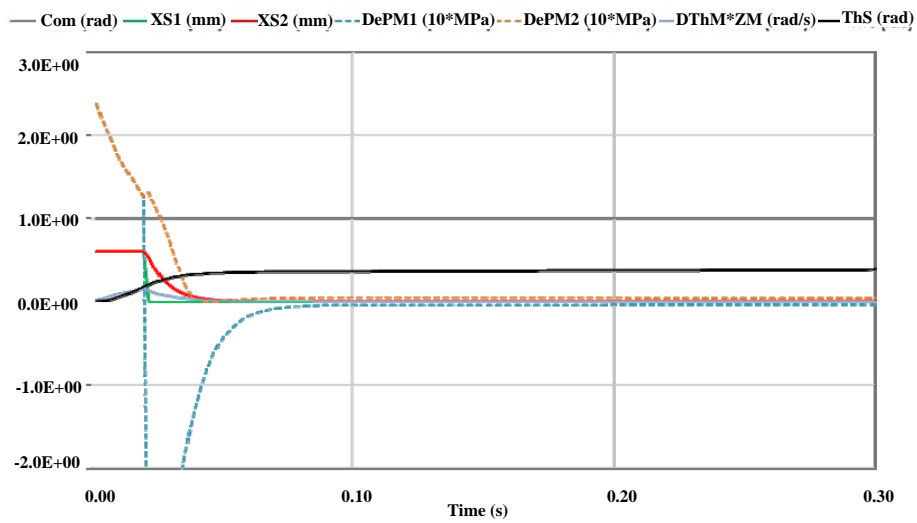

Fig. 7 System affected by a null position failure with spool position equalization device.

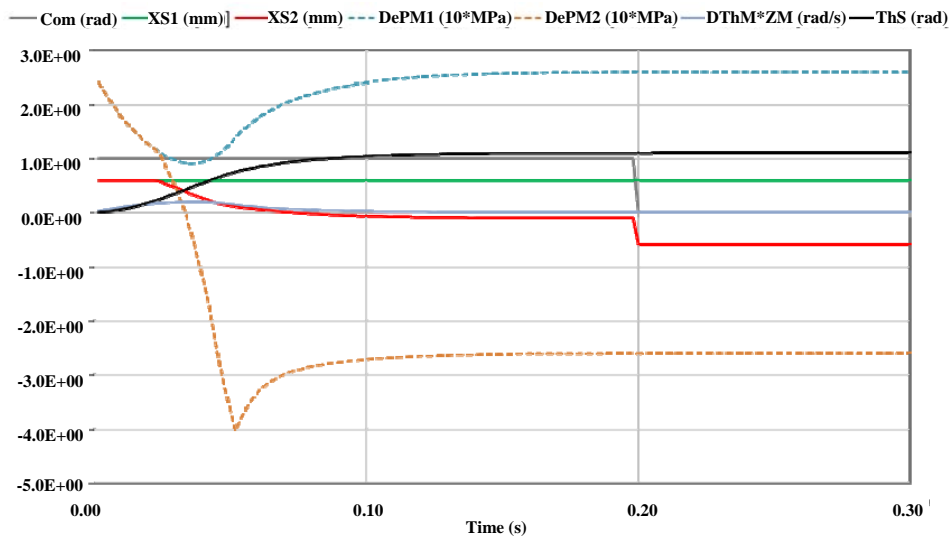

Fig. 8 System affected by a hard over failure without any type of equalization device.

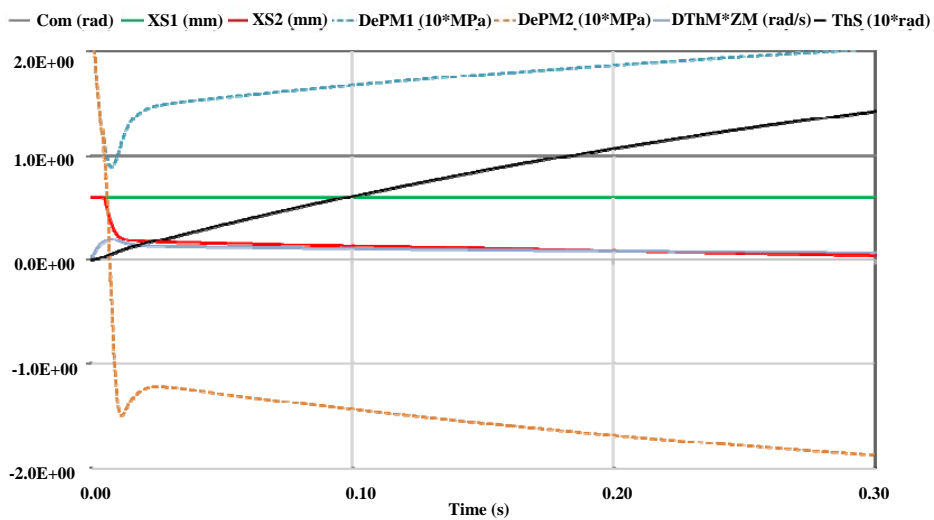

Fig. 9 System affected by a hard over failure with differential pressure equalization device.

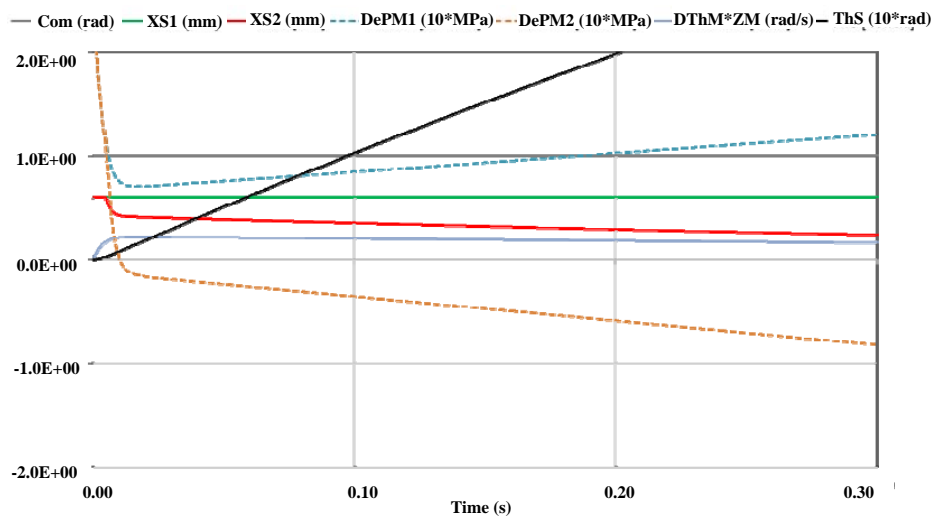

Fig. 10 System affected by a hard over failure with spool position equalization device.

subsystem 2 produces an increased differential pressure as a consequence of the reduced actuation rate; the achievement of the commanded position is asymptotically obtained under the strong damping action. In this case, the fully functional valve (subsystem 2) pursues the reduction of the position error; the failed valve (subsystem 1) develops a strong opposing action due to its centered position.

Fig. 5 shows the effects of a differential pressure equalization device with respect to Fig. 4.

The action of the equalization device leads to a markedly reduced actuation rate and the commanded position is reached much more slowly than in the previous case, because the equalization device produces a reduction of the spool displacement of the operational valve, in order to decrease the difference between the differential pressures.

Fig. 6 shows the servo-mechanism dynamic simulation of the above considered system having a reduced damping action as a consequence of the increased flow gain GQ , both in the failed and in the fully operational subsystem.

Fig. 7 regards the system characterized by a spool position equalization device. The equalization device performs the same reduced actuation rate as in case of Fig. 5, but the corrective action, based on the differential spool position, leads to a faster transient

following the failure.

Figs. 8-10 are referred to a system affected by a hard over failure without any type of equalization device (Fig. 8), with a differential pressure (Fig. 9) or spool position (Fig. 10) equalization device.

In Fig. 8 at time $t = 0.2$ s, the input command is returned to zero. In this case, the operational valve is able to reach any position opposite to the failed valve, so performing the maximum force fighting action.

As a consequence, the position error can not be reduced, but the system is maintained in a standstill condition. When the command is returned to zero, the operational valve spool is fully displaced, without any increased differential pressure, so performing no significant effect. In this conditions, the only positive actuation rate is performed; in case of negative actuation rate, the command is not developed, if no monitoring device and corrective action is available.

Fig. 9 shows the effects of a differential pressure equalization device with respect to Fig. 8. As a consequence of the equalization device, the fully operational valve is not able to contrast the action of the failed valve because its full opposite displacement is prevented, and the commanded position is widely overcome with consequent lack of control.

Fig. 10 shows the effects of a differential spool position equalization device: the same considerations

reported for the case of Fig. 9 can be done, the only difference concerning the further reduced contrast action performed by the operational valve.

4. Conclusions

The results show the effects of each type of failure related to the corresponding equalization device. Generally, the equalization device makes the situation worse with respect to the absence of the device itself. The reason of this behavior is the consequence of the reduced contrasting action performed by the operational valve against the failed one. A quick disengagement of the equalization device following the failure onset is absolutely necessary, and this operation must be done by a proper monitoring system. Its action is usually completed by the whole disengagement of the failed subsystem, so performing the maximum advantage.

In this work, the simulations are performed without any monitoring device and any type of shutoff action,

which are generally present in the actual redundant systems. The purpose of this approach is the specific analysis of the failure effects, independently on the eventual monitoring corrective actions, because the appropriate analysis of the failure effects leads the designer to the correct decisions about the selection of the proper monitoring device.

References

- [1] G. Jacazio, L. Borello, Mathematical models of electrohydraulic servovalves for fly-by-wire flight control systems, *Mathematical and Computing Modeling* 11 (1988) 563-569.
- [2] L. Borello, G. Villero, Comparison between control valves simplified models, in: XI A.I.D.A.A. National Congress, Forli, Oct. 14-18, 1991.
- [3] L. Borello, G. Villero, Flap control systems actuators: Mathematical and computational model for dynamic simulation, in: *European Congress on Computational Methods in Applied Sciences and Engineering (ECCOMAS 2000)*, Barcelona, Sept. 11-14, 2000.