

Performance of GMSK for telemetry and PN ranging under realistic conditions

Original

Performance of GMSK for telemetry and PN ranging under realistic conditions / Sessler, G.; Vassallo, E.; Visintin, Monica. - ELETTRONICO. - (2013), pp. 1-8. (Intervento presentato al convegno TTC 2013, 6th ESA International Workshop on Tracking, Telemetry and Command Systems for Space Applications tenutosi a Darmstadt, Germany nel 10-13 Sept. 2013).

Availability:

This version is available at: 11583/2514291 since:

Publisher:

ESA

Published

DOI:

Terms of use:

This article is made available under terms and conditions as specified in the corresponding bibliographic description in the repository

Publisher copyright

(Article begins on next page)

PERFORMANCE OF GMSK FOR TELEMETRY AND PN RANGING UNDER REALISTIC CONDITIONS

Gunther Sessler¹, Enrico Vassallo², Monica Visintin³

¹ *ESA/ESOC, Robert-Bosch-Str 5, Darmstadt, Germany, Gunther.Sessler@esa.int.*

² *ESA/ESOC, Robert-Bosch-Str 5, Darmstadt, Germany, Enrico.Vassallo@esa.int.*

³ *Dipartimento di Elettronica e Telecomunicazioni, Politecnico di Torino, Corso Duca degli Abruzzi 24, Torino, Italy, monica.visintin@polito.it*

I. INTRODUCTION

In the frame of CCSDS (Consultative Committee for Space Data Systems) activities, a system capable of simultaneously transmitting high rate telemetry and ranging has been studied in the last years. In this system the telemetry is transmitted through a GMSK (Gaussian Minimum Shift Keying) [1] modulator with the PN (Pseudo Noise) ranging sequence [2] included as an additional phase shift. The receiver first estimates the transmitted telemetry bits, regenerates and removes the estimated GMSK signal from the received signal, and then estimates the ranging chips and, through a bank of correlators, the round trip delay of the received ranging signal. Ranging is an interfering signal which degrades the performance of the telemetry subsystem, while errors in the estimation of telemetry bits compromise the correct detection of the ranging chips. The first simulation results obtained by ESA were presented in [3] and were limited to ideal synchronization and to the case of a telemetry bit rate equal to the ranging chip rate.

In this paper we describe additional results [4] obtained from the simulation of the complete system, including realistic synchronization, and for telemetry bit rates equal or almost equal to the chip rate. The paper organisation is as follows. Section II considers the effects of the receiver telemetry clock jitter on the regenerated GMSK signal and on the subsequent ranging receiver; it is shown that regeneration through the Laurent OQPSK approximation [5] or through a look-up table, which directly stores the GMSK phase for each combination of input bits, achieves good performance with low complexity. Section III discusses the effects of perfect synchronization between the transmitted telemetry and ranging signals: in this case, depending on the relative delay between the two signals, the recovered ranging clock may suffer from a bias, which corresponds to an error in the range estimation (lack of accuracy). Section IV provides the estimation of the system losses when the telemetry and ranging signals are synchronized or unsynchronized. Section V provides the estimation of the losses due to phase noise. The conclusions are drawn in Section VI.

II. EFFECTS OF THE RECEIVER TELEMETRY CLOCK JITTER

The analysis is limited to the case of pre-coded GMSK with $BT_b=0.5$ [1] and the Tausworthe PN ranging code T2B [2], which is the suggested scheme for deep space missions with demanding acquisition time requirements. The composite transmitted signal can be expressed as

$$x(t) = \sqrt{2P_T} \cos[2\pi f_c t + \varphi_{TM}(t - \tau_{TM}) + \varphi_{RG}(t - \tau_{RG})] \quad (1)$$

where $\varphi_{TM}(t)$ is the phase of the GMSK signal with bit interval $T_b=1/R_{TM}$, while

$$\varphi_{RG}(t) = h \frac{\pi}{2} \sum_k c_k h_{\sin}(t - kT_c) \quad (2)$$

is the ranging contribution, being h the modulation index (with analyzed values 0.05, 0.1, 0.2 and 0.3), c_k the k -th chip of the PN sequence, $T_c=1/R_{RG}$ the chip interval, $h_{\sin}(t) = \sqrt{2} \sin(\pi t/T_c)$ for t in $[0, T_c]$ and $h_{\sin}(t)=0$ elsewhere. The two delays τ_{TM} and τ_{RG} are used to introduce relative delays between the two components and in some cases are simulated as linearly time increasing delays, to model imperfect bit and chip rate synchronization.

The block diagram of the telemetry receiver is depicted in Fig. 1: it is assumed that the receiver signal complex envelope is present at the output of the mixer and the RX filter has impulse response $C_0(t)$ (the first pulse in the Laurent's decomposition of the GMSK signal [5]); the blue part of the scheme is the clock synchroniser, the green part is the carrier phase synchroniser; no channel encoder is simulated and the zero-threshold detectors are used to estimate the value of the transmitted telemetry bits. Since the ranging component is transmitted as a small phase shift of the GMSK signal, it is necessary to first remove the estimated telemetry signal from the received signal and then use the ranging receiver. If $\tilde{y}(t)$ is the complex envelope of the received

signal and \hat{b}_n is the estimated level ± 1 corresponding to the n -th telemetry bit, then the estimated telemetry component is obtained as [5]

$$\hat{w}(t) = \sum_n \hat{b}_{2n} C_0(t - 2nT_b) + j \sum_n \hat{b}_{2n+1} C_0(t - 2nT_b - T_b) \approx \exp[j\varphi_{TM}(t)] \quad (3)$$

so that it is possible to generate signal

$$\hat{z}(t) = \tilde{y}(t - \tau) \hat{w}^*(t) \approx \exp[j\varphi_{RG}(t - \tau)], \quad (4)$$

being τ the processing delay in the telemetry receiver. In (3), the GMSK signal is generated according to the Laurent's decomposition (truncated to the first term) as a filtered OQPSK signal, but other pre-coded GMSK modulator schemes can be used. If there is no noise, so that the telemetry bit error rate is zero, then $\hat{z}(t)$ is almost equal to $\sqrt{2P_r} \exp[j\varphi_{RG}(t - \tau)]$, and it is possible to make a decision on the value of c_k by taking the imaginary part of $\hat{z}(t)$ and using a filter with impulse response $h_{sin}(t)$ followed by a zero-threshold detector. The structure of the ranging receiver is shown in Fig. 2: the ranging sink includes 77 parallel correlators and 7 detectors that first estimate the phases of the 7 sub-codes that form code T2B, and then the overall phase of the received PN sequence. An approximate relation exists between (a) the probability of error in the estimation of the phase of the received PN sequence and (b) the chip error rate (CER); therefore, in the simulations, the ranging sink is substituted with a simple zero-threshold detector.

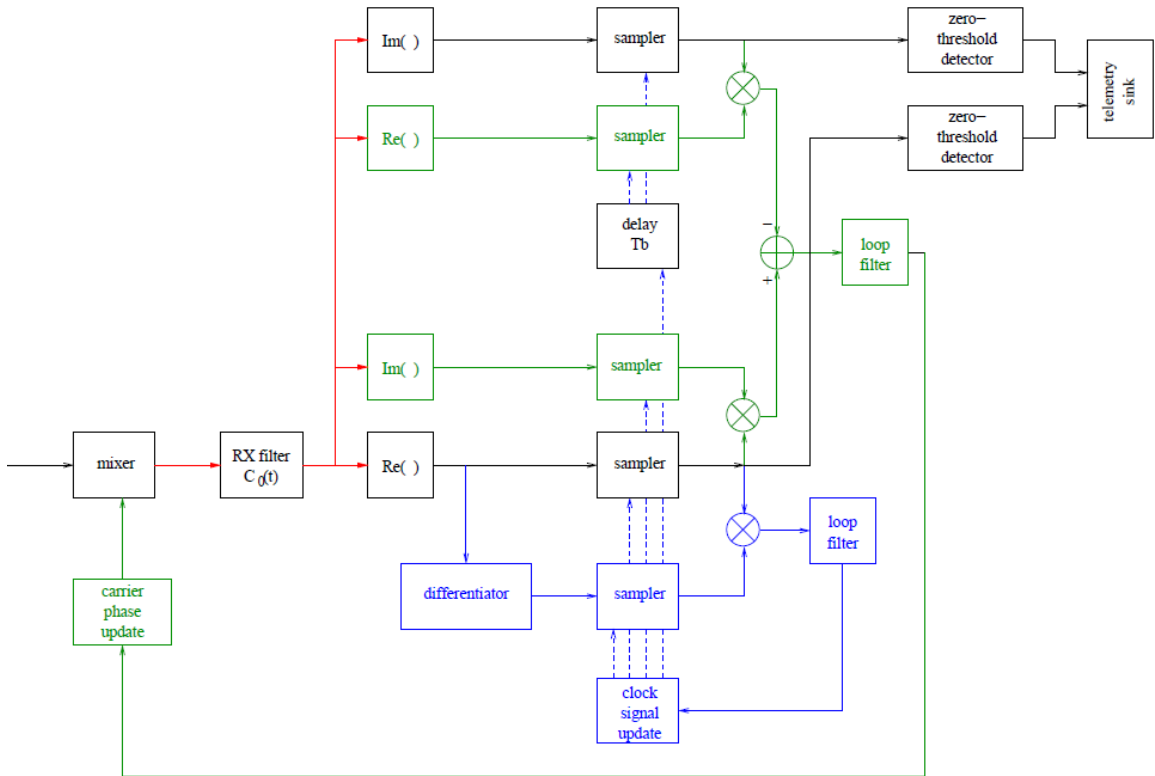

Fig. 1. Scheme of the telemetry receiver

In a realistic scenario, the performance of the ranging receiver is worsened by several impairments. The Gaussian additive noise not only directly affects the chip zero-threshold detectors, but causes a non-null telemetry bit error rate, so that the estimated telemetry component $\hat{w}(t)$ is wrong,

$$\hat{z}(t) \approx \sqrt{2P_r} \exp[2j\varphi_{TM}(t - \tau) + j\varphi_{RG}(t - \tau)], \quad (5)$$

and the estimated chip values are consequently wrong. Moreover, noise also causes jitter in the telemetry clock synchroniser, which means that the estimated telemetry bits \hat{b}_n are not generated at constant rate. In practice a more correct expression for the regenerated telemetry signal is

$$\hat{w}(t) = \sum_n \hat{b}_{2n} C_0(t - 2nT_b - \varepsilon_n) + j \sum_n \hat{b}_{2n+1} C_0(t - 2nT_b - T_b - \varepsilon_n) \quad (6)$$

where ε_n is a random variable with mean value equal to zero. If the Laurent's truncated expansion is used to regenerate the telemetry component, then the effect of clock jitter is some inter-symbol interference in $\hat{w}(t)$, and a small misalignment between the received and regenerated GMSK signal, which causes a small loss. If, on the contrary, the pre-coded GMSK signal is regenerated using a Gaussian filter followed by an integrator and a phase modulator (or directly a frequency modulator), then the effects are more severe. Due to clock jitter, (a) the duration of the estimated level \hat{b}_n is not equal to T_b , but $T_b + \varepsilon_n$; (b) also the duration of the pre-coded level \hat{e}_n is not equal to T_b , but $T_b + \varepsilon_n$; (c) the integral of signal $h_n(t)$, convolution between the rectangular pulse of duration $T_b + \varepsilon_n$ and the Gaussian impulse response of the filter, instead of being equal to $1/2$ is equal to $1/2 + \varepsilon_n/(2T_b)$; (d) level \hat{e}_n , instead of generating an asymptotic phase shift equal to $\pm\pi/2$, generates a phase shift equal to $\pm\pi/2 + \pi \varepsilon_n/(2T_b)$; (e) the phase of the regenerated GMSK signal is $\pi \sum_n \hat{e}_n h_n(t - nT_b - \varepsilon_n)$; (f) at a given time t this phase is the result of the time-varying contribution of recent levels and the asymptotic contribution of older levels; this last term should be equal to $N\pi/2$ (N integer), but it is equal to $N\pi/2 + \sum_n \pi \varepsilon_n/(2T_b)$. Therefore, the regenerated GMSK signal appears to be affected by a phase noise with a strong wandering component induced by the telemetry clock synchroniser jitter. If an all-digital receiver is used, with a small number of samples N_b per telemetry bit, then the duration of level \hat{e}_n becomes equal to an integer multiple of T_b/N_b (as if ε_n were quantized to an integer multiple of T_b/N_b) and (a) the resulting phase noise and wandering component become the dominating impairment, (b) the estimated telemetry component is completely different from the received one, even if the telemetry BER is equal to zero, and (c) the chip error rate tends to 0.5. The final comment is that the structure of the telemetry regenerator must be carefully designed, because it can prevent the correct working of the system. The simulation results given in Sect. IV were obtained using (3), but simulations were run to test a GMSK phase modulator, based on a look-up table which stores the phases $\varphi_{TM}(t)$ associated with a given sequence of bits [6], obtaining the same results.

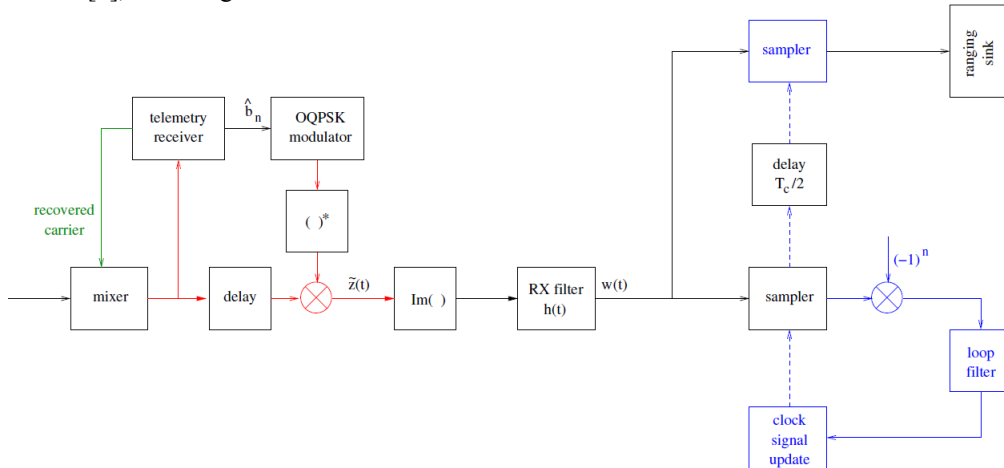

Fig. 2. Scheme of the ranging receiver

III. EFFECTS OF PERFECT SYNCHRONIZATION OF THE TWO COMPONENTS

Here it is assumed that $R_{RG} = R_{TM}$, that $\tau_{RG} = 0$ and $\tau_{TM} = \tau_0$ is fixed. Fig.3 shows the eye patterns of the signal at the output of the ranging Rx filter in the case in which (a) there is no noise (otherwise the eye patterns would be unreadable), but (b) the telemetry BER is forced equal to 0.1 (by XORing the detected bit sequence with a random sequence of zeros and ones in which bit one has probability 0.1). The BER value equal to 0.1 was chosen considering that, in the presence of channel encoding, the telemetry bit rate (before the decoder) is around 0.1 (while after the decoder it is 10^{-6} or lower). Due to the reciprocal interference between telemetry and ranging components, the synchronisers have non-negligible jitters.

Fig. 3 shows the eye patterns of signal $w(t)$ for some values of τ_{TM} . In the case of telemetry BER=0, the eye patterns would be all equal and only the part which oscillates between -0.2 and 0.2 would be present. The ranging chip synchronizer has the task to find the times of maximum aperture of the eye pattern, but it is evident that the maximum eye aperture occurs at times that depend on the value of τ_{TM} . In particular, it is anticipated when $\tau_{TM} = T_b/4$ and delayed when $\tau_{TM} = 3T_b/4$. This means that an offset is present between the true round-trip delay and its value estimated through the analysis of the received ranging signal; the offset depends on the random variable τ_{TM} . Moreover, with $\tau_{TM} = 0$, when a telemetry error occurs, the chip synchroniser is cheated by the more powerful telemetry spurious component and generates a clock signal that tries to track the telemetry component (in the picture maximum eye aperture at $t \approx T_c$), and then, when the estimated telemetry bit is correct, goes back to tracking the ranging component (in the picture maximum eye aperture at $t \approx T_c/2$). It is

clear that, when $\tau_{TM}=0$, the chip synchroniser jitter variance is much greater than when $\tau_{TM}=T_b/2$, since in this last case the maximum eye apertures of the telemetry and ranging components are time-aligned. These considerations are confirmed in the measured jitter standard deviations (see Fig. 4). When the modulation index h is large (for example equal to 0.3), then also the telemetry clock synchroniser is affected by the interfering ranging signal and the mean value and variance of the jitter depends on τ_{TM} .

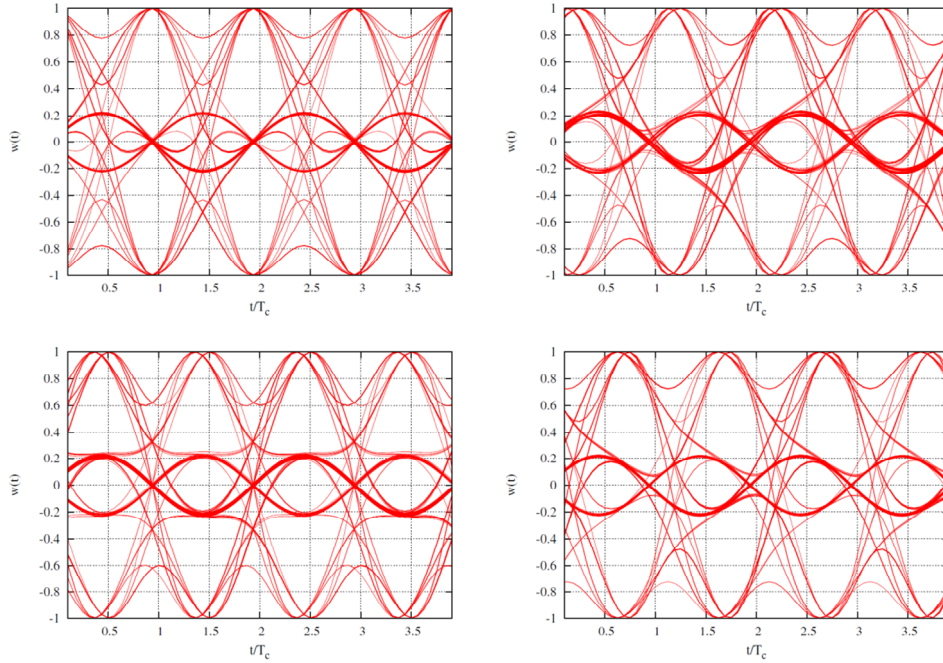

Fig. 3. Eye patterns of signal $w(t)$ for $\tau_{TM}=0, T_b/4, T_b/2, 3T_b/4$ (from left to right, top to bottom), case of T2B chip sequence, artificially included telemetry bit errors with BER= 0.1, $R_{TM}=R_{RG}$.

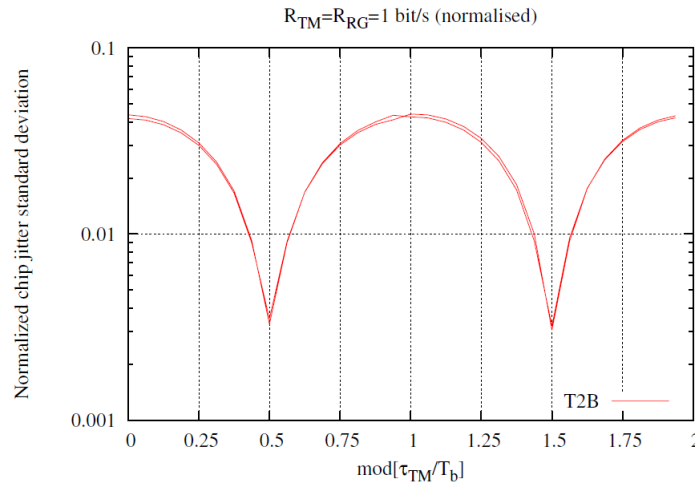

Fig. 4. Ranging chip jitter normalized standard deviation; no noise but with artificially included telemetry bit errors with BER=0.1; τ_{TM} was varied from 0 to $4T_b$ and the range $[2T_b, 4T_b]$ is shown superimposed to the range $[0, 2T_b]$ to emphasize the periodicity of the standard deviation.

IV. SYSTEM LOSSES

Simulations were run using the following parameters: nominal telemetry and chip rates normalized to 1 bps/cps, normalised loop noise equivalent bandwidths $B_L T_b = B_L T_c = 10^{-4}$ for all the synchronizers, second order loops, $\tau_{TM}(t) = \alpha t = 10^{-3} t$ and $\tau_{RG}(t) = 10^{-6} t$ (so that the real values of the rates are $R_{TM} = 1 \cdot 10^{-3}$ and $R_{RG} = 1 \cdot 10^{-6}$ to get unsynchronised signals) or $\tau_{RG} = 0$ and $\tau_{TM} = \tau_0$ from 0 to $2T_b$ (frequency synchronised signals, $R_{TM} = R_{RG} = 1$), number of simulated chips/bits equal to 10^6 plus an initial transient to allow for synchronization acquisition. A simple additive white Gaussian noise channel was considered with different values of power spectral density N_0 . Three target telemetry BER values were considered: 0.3 (case of turbo-codes with coding rate 1/6), 0.1 (case

of concatenated RS and convolutional encoding with rate 1/2), 10^{-2} (case of concatenated encoder with some signal to noise margin). Four values of modulation index h were considered: 0.05 (almost no interference on the telemetry component), 0.1, 0.2, 0.3 (very strong interference). For each h , the value of $E_{TM}/N_0 = P_T T_b / N_0$ was determined to obtain the desired telemetry BER value (see Tab. 1). The two different simulations (linearly time varying delays or fixed delays) provided the same results up to the second decimal digit for $h=0.05$ and 0.1, while E_{TM}/N_0 is slightly larger for the case of fixed delays for $h=0.2$ and 0.3 (the maximum difference being 0.1 dB for $h=0.3$ and BER=0.01). Tables 1-11 give the results for the case of time varying delays unless otherwise specified. The second column of Table 1 gives the values of E_{TM}/N_0 for the case of ideal 4PSK with no ranging signal ($h=0$). Tab. 2 gives the telemetry loss, i.e. the difference between the E_{TM}/N_0 value in dB for a given h and the E_{TM}/N_0 value in dB for ideal 4PSK. It can be seen that such loss varies between 0.03 and 2.03 dB.

Tab. 3 gives the normalised jitter standard deviation for the telemetry clock synchroniser at the values of E_{TM}/N_0 of Tab. 1 (the jitter standard deviation in seconds is obtained by multiplying the numbers of Tab. 3 by $2T_b$): for a given telemetry target BER the jitter standard deviation is practically independent of h .

Table 1. E_{TM}/N_0 (dB) that provides the target telemetry BER for each value of h .

Target BER	$h=0$ (4PSK)	$h=0.05$	$h=0.1$	$h=0.2$	$h=0.3$
0.3	-8.62	-8.53	-8.44	-8.12	-7.55
0.1	-0.86	-0.83	-0.73	-0.32	0.41
0.01	4.32	4.38	4.54	5.18	6.35

Table 2. Telemetry losses (dB)

Target BER	$h=0.05$	$h=0.1$	$h=0.2$	$h=0.3$
0.3	0.09	0.18	0.50	1.07
0.1	0.03	0.13	0.54	1.27
0.01	0.06	0.22	0.86	2.03

Table 3. Normalized standard deviation of the telemetry clock synchroniser jitter.

Target BER	$h=0.05$	$h=0.1$	$h=0.2$	$h=0.3$
0.3	0.0246	0.0244	0.0243	0.0241
0.1	0.0059	0.0059	0.0060	0.0061
0.01	0.0027	0.0028	0.0029	0.0033

The chip error rates at the values of E_{TM}/N_0 of Tab. 1 are listed in Tab. 4: the CER values decrease as h increases and the target BER decreases, when BER=0.3 the chip error rate is almost equal to 0.5. Tab. 4 gives CERs for the case of time varying delay, which are slightly larger than the CERs measured for the case of fixed delay, the difference being of the order of 10^{-3} . Tab. 5 lists the ratio E_{RG}/N_0 corresponding to the signal to noise ratio E_{TM}/N_0 of Tab. 1, being E_{RG} the energy per chip:

$$E_{RG} = (P_T T_c / 2) \left(1 - J_0 \left(\pi h \sqrt{2} \right) \right) \quad (7)$$

where $J_0(x)$ is the Bessel function of the first kind and order zero. The standard deviations σ_j of the normalized jitter $j(kT_c)$ for the chip synchroniser at the target BERs are given in Tabs. 6 (for the case of time-varying delay) and 7 (for fixed delays). The standard deviation in seconds σ_e is obtained by multiplying the values σ_j by the chip interval T_c . There is a slight difference between the results obtained with the two simulations, with smaller values in the case of fixed delays; the synchronizer does not lock when the target BER is 0.3 and $h=0.05$ or 0.1.

Table 4. CER at target BER (chip synchronizer bandwidth $B_L T_c = 10^{-4}$).

Target BER	$h=0.05$	$h=0.1$	$h=0.2$	$h=0.3$
0.3	0.49807	0.49529	0.48290	0.46777
0.1	0.47935	0.44486	0.38094	0.31818
0.01	0.43379	0.36182	0.22790	0.11062

Table 5. Values of E_{RG}/N_0 (dB) corresponding to the values of E_{TM}/N_0 of Tab. 1

Target BER	$h=0.05$	$h=0.1$	$h=0.2$	$h=0.3$
0.3	-30.64	-24.57	-18.39	-14.56
0.1	-22.94	-16.86	-10.58	-6.60
0.01	-17.72	-11.58	-5.09	-0.67

Table 6. Normalized standard deviation σ_j of the chip synchronizer jitter (time-varying delay), $B_L T_c = 10^{-4}$.

Target BER	$h=0.05$	$h=0.1$	$h=0.2$	$h=0.3$
0.3	-	-	1.17e-1	7.33e-2
0.1	1.39e-1	6.44e-2	3.11e-2	1.98e-2
0.01	5.93e-2	2.87e-2	1.36e-2	8.19e-3

Table 7. Normalized standard deviation σ_j of the chip synchronizer jitter (fixed delay), $B_L T_c = 10^{-4}$.

Target BER	$h=0.05$	$h=0.1$	$h=0.2$	$h=0.3$
0.3	-	-	1.15e-1	7.25e-2
0.1	1.27e-1	6.14e-2	2.96e-2	1.85e-2
0.01	5.71e-2	2.81e-2	1.33e-2	8.01e-3

By reducing the normalized loop noise equivalent bandwidth of the chip synchronizer $B_L T_c$ to 10^{-5} (and using 10 million chips for the measurements) the chip synchronizer is able to lock also for $h \leq 0.1$ (but with a very large jitter at BER=0.3 with $h=0.05$), as shown in Tab. 8. The rightmost 4 columns of Tab. 8 give the values of standard deviation for the case of no telemetry and same signal to noise ratio E_{RG}/N_0 ¹: apart from the case BER=0.3 with $h=0.05$, the telemetry interference increases the ranging standard deviation approximately by a factor 1.8 for BER=0.3, 1.17 for BER=0.1 and 1.05 for BER=0.01, with an equivalent ranging loss of 5.1 dB, 1.4 dB and 0.4 dB. Since the bandwidth is reduced by a factor 10, then the standard deviations in Tab. 6 should be equal to $\sqrt{10} = 3.16$ the values of Tab. 8: Tab. 9 therefore gives the values of Tab. 8 multiplied by $\sqrt{10}$, so that it is possible to appreciate the alignment between the standard deviations obtained with the two different bandwidths. When $B_L T_c = 10^{-5}$, CER is reduced, and the values are listed in Tab. 10.

Table 8. Normalized standard deviation of the chip synchronizer jitter (time-varying delay), $B_L T_c = 10^{-5}$.

Target BER	with telemetry				no telemetry, same E_{RG}/N_0			
	$h=0.05$	$h=0.1$	$h=0.2$	$h=0.3$	$h=0.05$	$h=0.1$	$h=0.2$	$h=0.3$
0.3	2.23e-1	7.72e-2	3.64e-2	2.34e-2	8.32e-02	4.07e-02	2.00e-02	1.28e-02
0.1	4.05e-2	2.03e-2	9.52e-3	5.96e-3	3.36e-02	1.67e-02	8.15e-03	5.16e-03
0.01	1.96e-2	1.04e-2	4.53e-3	2.73e-3	1.85e-02	9.15e-03	4.34e-03	2.60e-03

Table 9. Values of normalized stand. dev. of jitter of Tab. 8 multiplied by $\sqrt{10}$

Target BER	$h=0.05$	$h=0.1$	$h=0.2$	$h=0.3$
0.3	7.05e-1	2.44e-1	1.15e-1	7.40e-2
0.1	1.28e-1	6.43e-2	3.01e-2	1.88e-2
0.01	6.20e-2	3.30e-2	1.43e-2	8.63e-3

Table 10. CER at target BER (chip synchronizer bandwidth $B_L T_c = 10^{-5}$, time-varying delay).

Target BER	$h=0.05$	$h=0.1$	$h=0.2$	$h=0.3$
0.3	0.49619	0.48992	0.47720	0.46393
0.1	0.47107	0.44098	0.38041	0.31778
0.01	0.43081	0.36181	0.22841	0.11077

If ε (seconds) is the error of the chip synchroniser, then the error (meters) in the range estimation is $e = \varepsilon c/2$, being c the speed of light in vacuum. The standard deviation of the range estimation is $\sigma_e = \sigma_\varepsilon c/2 = \sigma_j T_c c/2$. Assuming, for example, that $R_{RG} = 1$ Mcps, $\sigma_\varepsilon \approx 150 \sigma_j$; assuming a normalized loop bandwidth 10^{-5} , then σ_e varies approximately from 33 m ($h=0.05$ and BER=0.3) to 0.4 m ($h=0.3$ and BER=0.01). The formula that approximately relates the acquisition time and CER is [2]

$$t_{acq} = L_{acq} T_c, \quad 10 \log_{10} L_{acq} \approx 24.17 - 20 \log_{10} \left(\text{erf}^{-1}(1 - 2 \text{CER}) \right) \quad (8)$$

where the coefficient 24.17 allows to obtain a probability of error in the estimation of the phase of the received T2B sequence equal to 10^{-3} . For the case $R_{RG} = 1$ Mcps and $B_L T_c = 10^{-5}$, the acquisition times are listed in Tab. 11, which also shows the acquisition times in the case of no telemetry and same E_{RG}/N_0 , so that the loss due to the telemetry interference can be appreciated. Apart from the cases BER=0.3 with $h=0.05$ and 0.1 for which a

¹ For example, the target BER=0.1 is obtained with $h=0.1$ at $E_{TM}/N_0 = -0.83$ dB, which corresponds to a value $E_{RG}/N_0 = -16.86$ dB; a simulation is run where only ranging is transmitted with $h=0.1$ and $E_{RG}/N_0 = -16.86$ dB, and the chip synchronizer jitter standard deviation is again measured.

narrower bandwidth should be used, telemetry increases the acquisition time by a factor approximately equal to 8.5 for BER=0.3, 1.9 for BER=0.1 and 1.1 for BER=0.01 equivalent to a ranging signal to noise ratio loss of about 9.3 dB, 2.8 dB and 0.4 dB.

Table 11. Acquisition time (s) (chip synchronizer bandwidth $B_L T_c = 10^{-5}$, $R_{RG} = 1$ Mcps).

Target BER	with telemetry				no telemetry, same E_{RG}/N_0			
	$h=0.05$	$h=0.1$	$h=0.2$	$h=0.3$	$h=0.05$	$h=0.1$	$h=0.2$	$h=0.3$
0.3	5.73	8.17e-1	1.60e-1	6.37e-2	3.91e-01	7.65e-02	1.81e-02	7.50e-03
0.1	9.91e-2	2.37e-2	5.64e-3	2.33e-3	5.19e-02	1.26e-02	2.99e-03	1.19e-03
0.01	1.72e-2	4.18e-3	9.43e-4	3.50e-4	1.55e-02	3.77e-03	8.46e-04	3.04e-04

In Tab. 7 each value of σ_j is obtained by averaging the values $\sigma_j(\tau_0)$ obtained at the end of each simulation with a given value of fixed delay τ_0 . Fig. 5 shows on the left $\sigma_j(\tau_0, E_{RG}/N_0)$ and it is possible to see the periodic dependency of jitter on τ_0 , especially at low signal to noise ratios, when BER is high, as already noticed in Sect. III. Fig. 5 shows on the right the mean value $E_j(\tau_0, E_{RG}/N_0)$ of the normalized jitter $j(k)$: again, the periodic dependency on τ_0 is clearly visible: a systematic error is present in the range estimation. The maximum error depends on the random relative delay τ_0 between the two synchronous telemetry and ranging components, on the target BER value and on the value of h . For $h=0.3$ the maximum value of $E_j(\tau_0, E_{RG}/N_0)$ is 0.05 for BER=0.3, 0.024 for BER=0.1 and 0.004 for BER=0.01; for $h=0.2$ the maximum value of $E_j(\tau_0, E_{RG}/N_0)$ is 0.05 for BER=0.3, 0.025 for BER=0.1 and 0.005 for BER=0.01; for $h=0.1$ the maximum value of $E_j(\tau_0, E_{RG}/N_0)$ is 0.03 for BER=0.1 and 0.006 for BER=0.01. It is apparent then that the maximum value of $E_j(\tau_0, E_{RG}/N_0)$ practically depends only on the value of BER and it can be reduced only by reducing the BER value. In the case of time-varying delay (non synchronous telemetry and ranging signals), the mean value of the jitter $j(kT_c)$ is null, but a periodic component appears in it, with period T_p such that $T_p = N_b T_b = N_c T_c$ with $|N_b - N_c| = 2$, N_b and N_c integer. This periodicity can be removed by choosing the chip synchronizer loop bandwidth B_L smaller than $f_p = 1/T_p = |R_{TM} - R_{RG}|/2$. In the current example, it is sufficient that the bandwidth is smaller than $5 \cdot 10^{-4}$ (and we have used 10^{-4} and 10^{-5}).

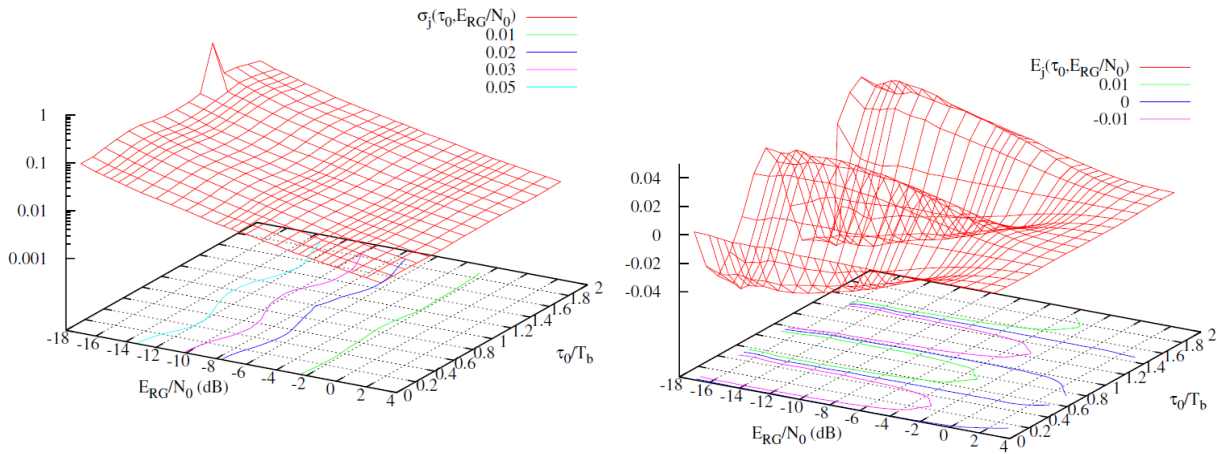

Fig. 5. Jitter standard deviation $\sigma_j(\tau_0, E_{RG}/N_0)$ and mean value $E_j(\tau_0, E_{RG}/N_0)$, case of fixed delay τ_0 , $h=0.3$, $B_L T_c = 10^{-4}$

V. EFFECTS OF PHASE NOISE

The considered phase noise mask is given in Tab. 12 and the ranging chip rate was set equal to 1 Mcps in the simulations. With the parameters of Tab. 12, the phase noise standard deviation σ_{φ_n} is equal to 1.51 degrees; a multiplying coefficient was used to change the standard deviation to 5, 10, 15 degrees. Phase synchronisation is performed by the telemetry receiver: if the phase synchroniser is too slow in tracking the phase noise, then the untracked phase could seriously impact the system performance, and particularly the ranging subsystem, since $\varphi_{RG}(t)$ takes very small values. Simulations were performed only for the target telemetry BER equal to 0.1. The telemetry loss (in terms of signal to noise ratio E_{TM}/N_0 or, equivalently power to noise ratio $C/N_0 = P_T/N_0$) due to phase noise amounts to 0.04 dB when $\sigma_{\varphi_n} = 5$ deg, 0.14 dB when $\sigma_{\varphi_n} = 10$ deg and 0.3 dB when $\sigma_{\varphi_n} = 15$ deg. The

increased value of C/N_0 is sufficient to keep the ranging chip error probability constant: if, in the absence of phase noise, a given (C/N_0) is necessary to have BER=0.1 and CER=0.444 for $h=0.1$, then, in the presence of phase noise, it is necessary to increase the signal to noise ratio to $(C/N_0)' > (C/N_0)$ to get BER= 0.1, but the resulting CER is again equal to 0.444.

Table 12. Spectrum of the phase noise variance

Freq. From f_0 (Hz)	10^1	10^2	10^3	10^4	10^5	10^6
$G(f)$ (dB rad ²)	-50	-70	-80	-90	-100	-100

VI. CONCLUSIONS

This paper shows that the telemetry signal regenerator prior to the ranging receiver should not be implemented using an integrator (direct FM modulation or integrator followed by PM modulation), and suggests that a simple I/Q modulator, or the look-up table based system described in [6] is used. In the simultaneous transmission of telemetry and ranging using the GMSK/PN scheme with bit rate equal to chip rate

- the parameter h must be chosen in order to balance the telemetry loss, the ranging acquisition time and chip synchronizer jitter;
- if R_{TM} and R_{RG} are exactly equal (perfect synchronization) an offset is present in the chip synchroniser, which depends on the random relative delay between the two signals;
- if R_{TM} and R_{RG} are nominally equal but actually different (non-synchronous), then a periodic component is present in the chip synchroniser jitter unless the loop bandwidth B_L is chosen less than $|R_{TM} - R_{RG}|/2$; the amplitude of this periodic component, in any case, depends on the telemetry BER (larger amplitude for larger BER values); also the telemetry clock synchronizer has a periodic component in the jitter, whose power increases with the modulation index h ;
- phase noise requires an increased signal to noise ratio to allow for a given desired telemetry BER, but no further increase is required by the ranging subsystem.

Since the ranging signal is generated by the ground station, while the telemetry signal is generated onboard the spacecraft, the case of perfectly equal rates $R_{TM}=R_{RG}$ is unlikely to happen, but care must be taken when setting the bandwidth of the chip synchronizer, so that the periodic component can be effectively removed from the jitter. In these conditions, if the ranging modulation index h is chosen appropriately with the target telemetry BER, the mutual losses can be reasonably small (less than 0.5 dB in terms of telemetry BER, 1.5 dB in terms of ranging jitter and 3 dB in terms of ranging acquisition time.)

Simulations run with $R_{RG} \approx 3R_{TM}$ showed that the acquisition times are close² to those listed in Tab. 11 but, for a given normalized loop noise equivalent bandwidth $B_L T_c$, the chip synchronizer jitter standard deviations are larger³ than those listed in Tab. 8 and locking is not achieved for $h=0.05$ with BER=0.3 even for $B_L T_c = 10^{-5}$. Moreover, the chip synchronizer jitter standard deviation and mean value are almost independent of τ_{TM} , since the telemetry interference is more effectively averaged out.

VII. REFERENCES

- [1] CCSDS Green Book 413.0-G-2, *Bandwidth-Efficient Modulations, Summary of Definition, Implementation and Performance*, October 2009
- [2] CCSDS Blue Book 414.1-B-1, *Pseudo-Noise (PN) Ranging Systems*, Issue 1, March 2009
- [3] E. Vassallo, M. Visintin *Analysis of GMSK for Simultaneous Transmission of Ranging and Telemetry*, TTC 2010
- [4] M. Visintin, *Synchronisation Analysis for GMSK/PN*, Final Report of ESA/ESOC P.O. 5001002756,
- [5] P.A. Laurent, *Exact and approximate construction of digital phase modulations by superposition of amplitude modulated pulse*, IEEE Trans. Commun., Vol. COM-34, pp.150-160, 1986.
- [6] G. M. A. Sessler, R. Abello, N. James, R. Maddè, E. Vassallo, *GMSK Demodulator Implementation for ESA Deep-Space Missions*, Proceedings of the IEEE, Vol. 95, No. 11, November 2007, pp. 2132-2141
- [7] G. Boscagli, P. Holsters, E. Vassallo, M. Visintin, *PN Regenerative Ranging and Its Compatibility With Telecommand and Telemetry Signals*, Proceedings of the IEEE, Vol. 95, No. 11, November 2007, pp. 2224-2234

² Theoretically, the acquisition times do not depend on the chip rate [7].

³ The loop signal to noise ratio is decreased by a factor $10 \log_{10}(3)$ due to the reduced chip energy.