

A Prevention through Design Approach for the
Environmental S&H Conditions and the Ventilation System

Original

A Prevention through Design Approach for the Environmental S&H Conditions and the Ventilation System at an Italian Underground Quarry / Borchiellini, Romano; Cardu, Marilena; Colella, Francesco; Labagnara, Davide; Martinetti, Alberto; Patrucco, Mario; Sandrin, D.; Verda, Vittorio. - STAMPA. - 32:(2013), pp. 181-186. ((Intervento presentato al convegno 11th International Conference on Chemical & Process Engineering tenutosi a Milano nel 2-5 giugno 2013 [10.3303/CET1332031]).

Availability:

This version is available at: 11583/2513870 since:

Publisher:

AIDIC - The Italian Association of Chemical Engineering

Published

DOI:10.3303/CET1332031

Terms of use:

openAccess

This article is made available under terms and conditions as specified in the corresponding bibliographic description in the repository

Publisher copyright

(Article begins on next page)

A Prevention through Design Approach for the Environmental S&H Conditions and the Ventilation System at an Italian Underground Quarry

Romano Borchiellini^a, Marilena Cardu^b, Francesco Colella^c, Davide Labagnara^{*b}, Alberto Martinetti^b, Mario Patrucco^b, Davide Sandrin^d, Vittorio Verda^a

^aDepartment of Energy - DENERG - Politecnico di Torino, Corso duca degli Abruzzi 24, 10129, Torino

^bDepartment of Environment, Land and Infrastructures Engineering - DIATI - Politecnico di Torino, Corso duca degli Abruzzi 24, 10129, Torino, Italy

^cExponent, 149 Commonwealth Drive Menlo Park, CA 94025, U.S.A.

^dGruppo Minerali Industriali S.p.A., Piazza Martiri della Libertà 4, 28100, Novara, Italy
davide.labagnara@polito.it

Even if the number of the Italian quarrying operations in underground is steadily growing, in many cases the safety criticalities are somehow underestimated, in spite of the regulations D.Lgs. 81/08 and D.Lgs. 624/96, Italian enforcements of the European Directives.

Ventilation system is conceived to face very simplified requirements, whilst critical pollutants or emergency situations are not taken in due considerations. Besides, the ventilation system fault and availability analysis is seldom included in the project.

The paper deals with the results of a research work started some years ago at an underground quarry exploited through drift sublevel based on drill and blast technique, to identify criteria suitable to grant effective safety and health -S&H- conditions for the workers operating in the underground in the Prevention through Design approach.

Taken into account that the phases for an effective approach to the S&H problems in underground must follow a hierarchic method in which the risk management should be faced from an effective hazard reduction to a minimum at the sources, and the ventilation should be considered only as a 4th level solution, the possibilities of control at the main pollution sources, i.e. the emission of pollutants due to the rock winning and mucking operations, have been examined.

The residual risk was then faced with both the original underground and airways layout definition for a new exploitation development, based on technical and efficiency considerations, and on fire emergency computer simulations.

Finally, the paper summarizes the results of an availability analysis of the ventilation system for the normal operating conditions and the emergencies management, on the basis of the results of Hazard Evaluation techniques, in particular Hazard and Operability Analysis and Fault Tree Analysis.

1. The Method

The control of the underground environment involves the adjustment, modification, alteration, or correction of an existing or incipient undesirable situation in order to attain or maintain safe working conditions (Bersano et al., 2010).

In order to carefully identify all the possible situations, the general underground layout in an Italian quarry was analysed with the use of simulation software fed with directly collected input data, and some modifications introduced, on the basis of the assumption that an upward flow has to be granted in any situation, and both the flow reversal risk and the presence of workers in the fumes polluted areas should be avoided at the very first stage of the ventilation layout and fittings design (with special reference to the

possible presence of workers in areas polluted by fire fumes, the residual risk not directly eliminated by the underground layout design must be managed in terms of organization, and, if necessary, with the introduction of rescue chambers).

The first step was the direct measurement of pressure (in terms of pressure difference along the airways) and flow-rate (from velocity and airway cross section) in 17 representative stations along the main airways¹: a series of measurement campaigns carried out in different seasonal conditions made available the different values of the aforesaid parameters due to the different natural draft, and to the thermal contribution of the machineries, often sufficient to overcome the head losses. It must be underlined that the latter statement involves the possibility of natural descending ventilation, with the possibility of flow reversal in case of fire: such a situation can be managed only by the adoption of a mechanized ventilation system including a fan located at the higher level (1,530 m) to grant a constant ascending flow from the clean air entrance (1,490 m) in all seasonal, weather and underground situation.

2. The Numerical Simulation

The simulation analysis was carried out through combined application of two different approaches: 1) 1D simulation of the entire quarry to evaluate the airflows on the basis of the data acquired through the measurement campaigns (Figure 1), and to identify the best layout and ventilation hardware (fan, monitoring and regulation devices, etc.). 2) Computational Fluid Dynamics (CFD) in different areas of the underground using the results of the 1D model as the boundary conditions to obtain local distributions of velocity, temperature, smoke, etc. Different fire emergency scenarios corresponding with 10 MW fire have been considered. The 1D simulations have been conducted using a software developed at Politecnico di Torino (Borchiellini et al., 2011), while CFD simulations have been conducted using the software FDS (Baum et al., 2007 and NIST, 2010).

Finally, to optimize and simplify the layout of the airways, and properly simulate the possible interventions necessary for the management of the natural draft, the boundary condition of total closure of a shaft connecting the 1,518 m level to abandoned underground exploitations at higher levels was assumed (so avoiding obvious short circuits in the general ventilation net).

The results of the computer analyses can be summarized as follows:

- a) The most critical situation corresponds to a fire located in the node "N20" at 1,490 m level (Figure 2), which represents the main point of distribution of the fresh air to the whole underground, so that further detailed analysis appeared advisable;
- b) The 1D analysis put in evidence the risk of convective movements of polluted air: in particular in a hypothetical scenario of fire in the node "N20", it was possible to verify such a situation between the already exploited rooms "N", "P", "Q" and "R". This phenomenon can only worsen the conditions during an emergency, substantially contributing to the rapid pollution of the whole interested levels (Figure 3). It should be moreover emphasized that also a saturation of the available air volumes can occur, leading to incomplete combustion and production of under-oxidised gases. Some modifications in the ventilation layout were then hypothesized, in particular with the exclusion from the ventilation net of all the already exploited rooms located at the 1,490 m level together with the "R24", "R47" and "R48" branches: the proposed modified layout grants a substantial reduction of uncontrolled -and unnecessary- air movements, and appeared to be suitable for a well-defined analysis and management of the underground ventilation in both normal and critical conditions.



Figure 1, 2: Measurement of the air flow in underground by means of anemometer at node "N20"

¹ The spot data resulting from the campaigns were confirmed by routine simplified measurements systematically carried out by the underground supervisors.

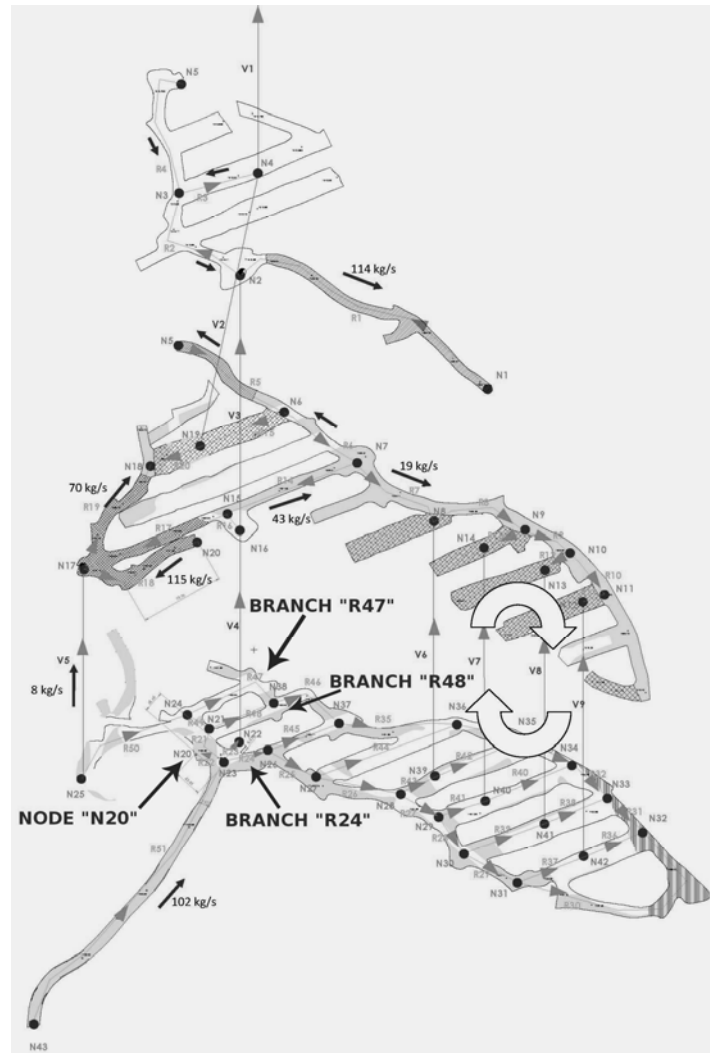

Figure 3: Underground levels scheme adopted in the simulations carried out with a 1D nodal points software

c) The CFD analysis applied in the node "N20" confirmed, as shown in Figures 4 and 5, the criticality of this particular node, and provided detailed information of the possible development -step by step along the time- of a 10 MW fire In terms of air temperature and velocity.

From the aforesaid results the ventilation layout was confirmed, and it was possible to define the most suitable characteristics of the fan to be introduced.

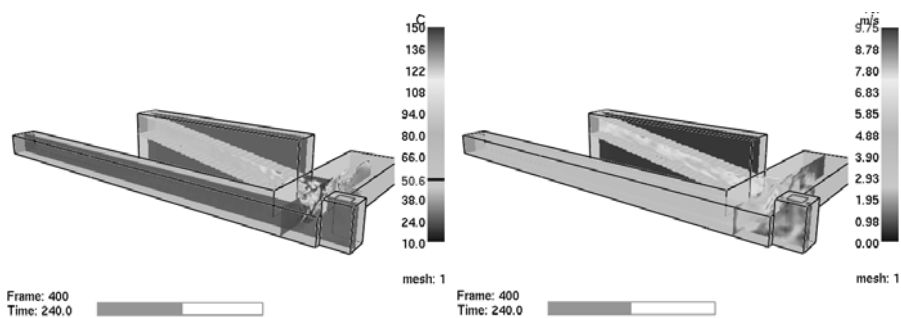

Figure 4, 5: temperature and velocity at 240 seconds during a 10 MW power fire at node "N20"

3. The definition of the characteristics of the main Fan

The main fan to be located at 1530 m level was dimensioned to fulfil the following requirements:

- The management of the seasonal variations of the natural draft, so that an upward air flow is in any case granted, taken into account that the computer simulations suggested a maximum value of the possible downward natural flow movement of $\approx 80,000 \text{ m}^3/\text{h}$;
- The capability of an effective management of the diesel fumes emitted by the mining equipment (the fire load is preliminarily minimized, and exclusively approved diesel machines are allowed into the underground): basically the trucks used for the mineral transportation at the 1,490 m base level (see Table 1);
- the regulations on the minimum/maximum (0.1 m/s - 6 m/s) air velocity in the underground according to the Italian regulation D.P.R. 128/59, art. 261.

Such an approach was considered acceptable, provided that a) no exploitation areas are ventilated in series, b) the fresh air intake way is different from the mined ore transportation way, c) a special risk assessment and management is carried out to grant safe conditions on the basis of organization, and, if necessary, of rescue chambers for the fire emergency situations.

In conclusion, through a comparison with the suggested Limit Values -Tables 1 and 2-, and taken into account the possible seasonal situations of downward natural draft, a suitable fan should be characterized by prevalence values in the range $1,000 \div 3,000 \text{ Pa}$, and a flow value of at least $250,000 \text{ m}^3/\text{h}$.

Table 1: Threshold Limit Values in a 8 hours Time Weighted Average (TLV-TWA) (American Conference of Governmental Industrial Hygienist, 2012)

substance [n CAS] (publishing date)	TLV-TWA
Carbon Dioxide [124-38-9] (1983)	5,000 ppm
Carbon Monoxide [630-08-0] (1989)	1 ppm
Nitrogen Oxide [10102-43-9] (1992)	25 ppm
Particulate Matter (provided that no substances with an applicable TLV are present (²))	10 mg/m ³ (inhalable) 3 mg/m ³ (respirable)

Table 2: Permissible Exposure Level (PEL) in a 8 hours time weighted average for Diesel Particulate Matter in underground mining operations (Mine Safety and Health Administration, 2008)

substance	PEL
Total Carbon (D ₅₀ = 0,2 µm)	160 µg/m ³

In the hypothesis that a special risk analysis and management is carried out to grant safe conditions of the workers on the basis of organization and where necessary of rescue chambers, such a fan can be considered suitable to manage also the emergency situations. Obviously, taken into account the important seasonal variations in the natural draft, special care should be devoted to the underground environment automatic monitoring and fan regulation, both to save energy and to grant a correct response also in case of emergency.

4. The Hazard Identification Technique Selected to evaluate the Availability of the system

According to the results of research work carried out by the Authors (Bersano et al., 2011), the Hazard and Operability Analysis -HAZOP- and the Fault Tree Analysis -FTA- techniques have been employed in combination to identify and analyze the criticality of ventilation systems in underground operations.

4.1 HAZOP – Hazard and Operability Analysis

The first step of the Hazard Identification was the implementation of a systematic analysis HAZOP on the complex ventilation - detection, to highlight the possible deviations, put in evidence the unwanted events (Top Events) and draft a hierarchical order of the criticalities.

The more critical event identified was *the rapid filling of smoke of some areas of the underground* due to a fire not correctly managed by the ventilation system (Table 3).

² The presence of crystalline silica is systematically monitored by the quarry technicians, and the Author were informed that it is play a critical role in the ventilation flow rate definition, in comparison with the diesel fumes.

Table 3: HAZOP analysis

	Process	Parameter	Deviation	Cause	Effects (worst credible case)
	Ventilation V	Q clean air 1	No	Improper response of the ventilation to an emergency alarm	Rapid filling of smoke not faced by the ventilation system
			Less	Improper response of the ventilation to an emergency alarm	Filling of smoke not completely contrasted by the ventilation
			More	Improper response of the ventilation to an emergency alarm	A not particularly critical situation, provided that correct organization and, if necessary, rescue chambers are available

4.2 FTA – Fault Tree analysis

To analyze the qualitative interactions among the identified initiator Events, the FTA technique was used. The Top Event the being a rapid filling of smoke in some underground areas (Figure 6).

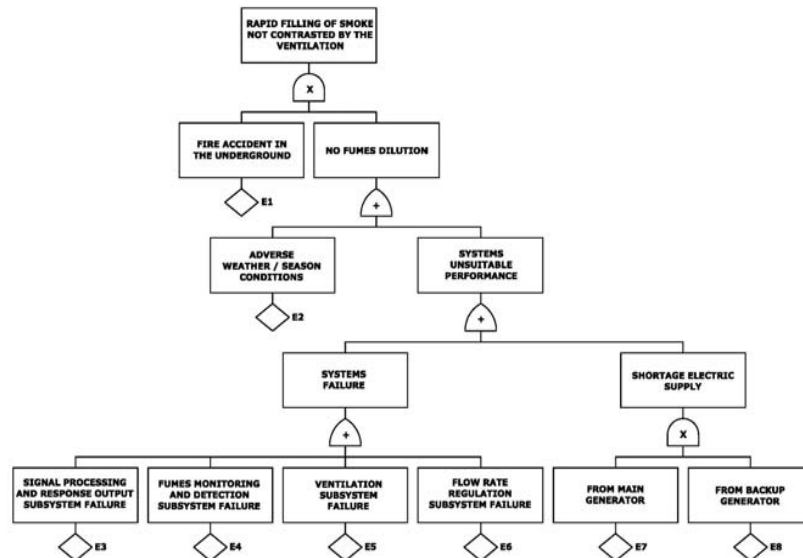

Figure 6: Qualitative Fault Tree Analysis of the ventilation system

The qualitative FTA confirmed the importance of maintenance, management strategies, indispensable in any sector and without which the analysis of the availability of mechanical components becomes useless.

5. Analysis of the fumes resulting from the blasting operations

The fumes of an explosion are certainly unbeatable for the very low or nil oxygen content, but there is also concern of their toxicity, in particular in underground, where the renewal of air is not so rapid and complete as in open pit quarrying (some underestimated problems can arise, as discussed in Berry et al. (1993)). The analysis of fumes produced by detonating explosives can be helpful to control the environmental condition in underground mining. Ideally, the detonation products of explosives could be water (H₂O),

carbon dioxide (CO₂) and nitrogen (N₂); but, due to the kinetics of the chemical reaction, also toxic fumes, such as nitrogen dioxide (NO₂), nitric oxide (NO), carbon monoxide (CO) and in relation to the type of explosive, sulphur dioxide (SO₂), ammonia (NH₃) and others, are produced.

The quantity of oxygen leads the explosives to a positive or negative balance: an excess of oxygen increases the production NO_x, while a deficiency facilitates the CO production.

Moreover, it was observed that the confinement of a charge considerably influences the production of NO_x and CO; this is due to the oxidation of NO to NO₂, that depends mainly on the initial concentration of NO in the environment. A reduced confinement, on the contrary, allows the gases to propagate immediately after the blast at a very high temperature, due to the little work they have done: to limit this effect it is advisable to leave a 10 diameters length of uncharged hole.

The formation of CO, even if in some way influenced by confinement, depends on the oxygen balance.

In order to evaluate the actual risk of exposure of the operators, the performance of the explosive and the physico-chemical characteristics of the gases, on-site sampling of gases was performed. The measurements of concentration of pollutants was focused in particular in the mucks and in the abandoned branches before blasting, and three hours after the smoke cleaning in four identified points with a Drager detector. These measures were carried out to, especially in the case of loading, where the operation requires the staff to stay close to the source of pollutant.

The explosive used in the quarry is a waterproof dynamite (GD) with an amount of harmful gases released less than 22.7 l/kg of explosive in order to quickly re-establish the proper conditions after the detonation.

The measurements showed that the concentrations of pollutants were maintained below the limits of sensitivity of the instrument: only nitrogen oxides (NO_x) and carbon dioxide (CO₂) reached concentrations sufficient to be detected, although systematically lower than TLV-TWA values.

6. Conclusion

The present study results confirm the actual possibility of an effective new approach for the improvement of the environmental Safety and Health conditions both in normal and emergency conditions.

In particular the numerical simulations of a fire accident proved to be quite precious to define both the new underground layout and the fan characteristics, whilst the HAZOP and FTA analysis provided useful suggestions for the ventilation system design.

The analysis of the blasting operations led to effectiveness improvement and to a pollutant reduction.

References

- American Conference of Governmental Industrial Hygienist, 2012, Threshold limit values for chemical substances an physical agents and biological exposure indices, Signature Publications, Cincinnati, Ohio.
- Baum H., Floyd J., Hostikka S., McGrattan K., Rehm R., 2007,. Fire Dynamics Simulator (Version 5), Technical Reference Guide, National Institute of standards and Technology.
- Berry P., DeVirgilio F, Patrucco M., Sammarco O., 1993, The emission of fumes from blasted rock in underground mines: a case study in Italy, proceeding for International Conference Minesafe 1993, Perth, Australia, 47-52.
- Bersano D., Cigna C., Patrucco M., Pession J.M., Ariano P.F., Prato S., Romano R., Scioldo G., 2010, Extractive activities start up and management: a computer assisted specially developed "Prevention through Design" approach, International Journal of Mining, Reclamation and Environment, 24 Issue 2, 124-137, DOI: 10.1080/17480930903003680.
- Bersano D., Labagnara D., Patrucco M., Pellegrino V., 2011, Reliability: the "Cinderella" during the planning phase of the tunnelling ventilation system (in Italian), GEAM - Geingegneria ambientale e mineraria, XLVIII 133, 17-26.
- Borchiellini R., Colella F., Rein G., Verda V., 2011, One-dimensional and multi-scale modelling of tunnel ventilation and fires, Handbook of Tunnel Fire Safety, Second Edition, Beard and CarvelEditors.
- Italian Regulation, 1959, Decreto Presidente della Repubblica 128 concerning the mine activities.
- Italian Regulation, 1996, Decreto Legislativo 624 concerning the safety and health at extractive activities.
- Italian Regulation, 2008, Decreto Legislativo 81 concerning the safety and health at work places.
- Mine Safety and Health Administration (MSHA), 2008, Diesel Particulate Matter Exposure of Underground Metal and Nonmetal Miners <www.msha.gov/30cfr/57.5060.htm>, accessed 05.02.2013.
- National Institute of Standards and Technology (NIST), 2010, FDS and Smokeview <www.nist.gov/el/fire_research/fds_smokeview.cfm>, accessed 05.02.2013.