

Lightning protection of PV systems

Original

Lightning protection of PV systems / Pons, Enrico; Tommasini, Riccardo. - ELETTRONICO. - (2013). (Intervento presentato al convegno 4th International Youth Conference on energy tenutosi a Siofok, Hungary nel 6-8 June 2013) [10.1109/IYCE.2013.6604209].

Availability:

This version is available at: 11583/2513842 since: 2016-11-21T19:20:58Z

Publisher:

IEEE

Published

DOI:10.1109/IYCE.2013.6604209

Terms of use:

This article is made available under terms and conditions as specified in the corresponding bibliographic description in the repository

Publisher copyright

(Article begins on next page)

Lightning Protection of PV Systems

Enrico Pons and Riccardo Tommasini

Abstract--Lightning strikes can affect photovoltaic (PV) generators and their installations, involving also the inverter's electronics. It is therefore necessary to evaluate the risk connected to lightning strikes in order to adopt the correct protective measures for the system. The Standard IEC (EN) 62305-2 reports the procedures for the risk calculation and for the choice of proper lightning protection systems. Usually the technical guidelines suggest protecting with SPDs (surge protective devices) both DC and AC sides of the PV installation.

The paper estimates overvoltages due to lightning discharges and evaluates the actual need of lightning protection measures on the basis of the results of the risk analysis and of the protection costs. The paper in the first part presents the procedure for the evaluation of the risk connected to lightning strikes according to the Standard IEC EN 62305-2; then it applies the procedure to typical PV installations, analyzing risks and risk components which have to be kept into account. In the second part the paper studies the surge overcurrents to be expected on LV systems, induced voltages caused by direct flashes and by flashes near the PV installation. Approximated equations for the calculation of induced voltages and currents are given for different types of LPS (lightning protection systems) and lightning flashes. In the last part of the paper the methodology is applied as an example to a practical case and some conclusions are given.

Index Terms--Lightning protection, photovoltaic systems, risk analysis, SPD, surges.

I. ACRONYMS

AC	Alternating Current
DC	Direct Current
LEMP	Lightning Electro-Magnetic Pulse
LPL	Lightning Protection Level
LPS	Lightning Protection System
LV	Low Voltage
PV	Photovoltaic
SPD	Surge Protective Device
SPP	Solar Power Plant

II. INTRODUCTION

PHOTOVOLTAIC systems are becoming widespread thanks to the reduction of the installation costs and the incentives that in many countries are being provided.

Not only private households are installing PV systems on their roofs but also private operating companies are making more and more investments in shared systems, which are built

on large-surface roofs, on traffic structures, or unused open areas.

Because of the large surface occupied by photovoltaic generators, they are especially threatened by lightning strikes during thunderstorms [1].

The installation of PV modules on buildings does not increase the risk of a lightning strike itself, but there may be an increased damage for the electric installation of the building in the event of a strike. This is based on the fact that, due to the wiring of the PV lines inside the building (in existing risers and cable runs) strong conducted and radiated interferences may result from lightning currents.

The aim of the designer should be to protect both the building and the PV system against damage caused by fire (direct lightning strike), and the electrical and electronic systems (inverters, remote diagnostics system, generator main line) against the effects of lightning electromagnetic pulses (LEMP).

The problem of the protection of PV Installations has been studied in the past from the point of view of preventing direct lightning strikes by building external LPSs [2],[3]. The problem, however, is more complicated; in fact also in case of lightning strike near the PV system the installations could be damaged due to overvoltages and overcurrents. Previous studies have showed that overvoltages could reach important values [4] and therefore the installation of overvoltage protection is important on both sides of the power electronic devices (e.g. charge controllers and inverters) [5].

The correct approach is a risk assessment performed according to the Standard IEC EN 62305 series [6],[7],[8],[9] as described also in [10] and [11].

In this paper the general procedure for risk assessment is summarized and it is then adapted to the case of a PV system. Particular insight is given to the problem of surge overcurrents and induced voltages and approximated equations are given for their calculation for different types of LPSs.

III. RISK EVALUATION ACCORDING TO IEC EN 62305-2

According to Standard IEC EN 62305-2 [7] a risk evaluation has to be performed in order to determine whether a structure should be protected against lightning flashes.

In this paragraph the general evaluation procedure is described. It will then be applied to the particular situation in which the structure to be protected is a PV system.

Four different sources of damage are recognized by the Standard, which are:

- S_1 – flashes to the structure;
- S_2 – flashes near the structure;

E. Pons is with Politecnico di Torino - Dipartimento Energia, C.so Duca degli Abruzzi 24, 10129 Torino, ITALY (e-mail: enrico.pons@polito.it).

R. Tommasini is with Politecnico di Torino - Dipartimento Energia, C.so Duca degli Abruzzi 24, 10129 Torino, ITALY (e-mail: riccardo.tommasini@polito.it).

- S₃ – flashes to a service;
 S₄ – flashes near a service.

Three basic types of damage which can appear as the consequence of lightning flashes are also distinguished:

- D₁ – injury to living beings;
 D₂ – physical damage;
 D₃ – failure of electrical and electronic systems.

Each type of damage, alone or in combination with others, may produce the following types of losses, that have to be considered:

- L₁ – loss of human life;
 L₂ – loss of service to the public;
 L₃ – loss of cultural heritage;
 L₄ – loss of economic value.

For each type of loss, the relevant risk shall be evaluated (the risk is the value of the probable average annual loss); the risks to be evaluated in a structure are therefore the following:

- R₁ – risk of loss of human life;
 R₂ – risk of loss of service to the public;
 R₃ – risk of loss of cultural heritage;
 R₄ – risk of loss of economic value;

Each risk is the sum of different risk components, which may be grouped according to the source of damage and the type of damage.

A. Risk components for a structure due to flashes to the structure itself

- R_A – component related to injury to living beings caused by touch and step voltages;
 R_B – component related to physical damage caused by sparking inside the structure triggering fire or explosion;
 R_C – component related to failure of internal systems caused by LEMP (lightning electromagnetic impulse).

B. Risk component for a structure due to flashes near the structure:

- R_M – component related to failure of internal systems caused by LEMP.

C. Risk components for a structure due to flashes to a service connected to the structure:

- R_U – component related to injury to living beings caused by touch voltage inside the structure, due to lightning current injected in a line entering the structure;
 R_V – component related to physical damage (fire or explosion triggered by sparking between external installation and metallic parts) due to lightning current transmitted through or along incoming services;
 R_W – component related to failure of internal systems caused by overvoltages induced on incoming lines and transmitted to the structure.

D. Risk component for a structure due to flashes near a service connected to the structure:

- R_Z – component related to failure of internal systems caused by overvoltages induced on incoming lines

and transmitted to the structure.

According to IEC EN 62305-2, the following risk management procedure shall be followed:

- identification of the object to be protected and its characteristics;
- identification of all the types of losses in the object and the relevant corresponding risk R (R₁ to R₄);
- evaluation of risk R for each type of loss (R₁ to R₄);
- evaluation of the need of protection, by comparison of risk R₁, R₂ and R₃ for the structure with the tolerable risk R_T;
- evaluation of the cost effectiveness of the protection by comparison of the costs of total loss with and without protection measures. In this case, the assessment of all the components of risk R₄ for a structure shall be performed in order to evaluate such costs. Another approach is to compare the risk R₄ with a tolerable risk defined by the owner of the PV system.

IEC EN 62305-2 reports representative values of the tolerable risk R_T for loss of human life and loss of social or cultural values (TABLE 1).

TABLE 1
 TYPICAL VALUES OF TOLERABLE RISK R_T

Types of loss	R _T [Years ⁻¹]
Loss of human life or permanent injuries	10 ⁻⁵
Loss of service to the public	10 ⁻³
Loss of cultural heritage	10 ⁻⁴

If protection measures are required (R > R_T), they shall be selected according to the share of each risk component in the total risk R.

Each risk component can be evaluated by mean of an expression similar to the following:

$$R_x = N_x \times P_x \times L_x \quad (1)$$

where:

- N_x is the number of dangerous events per year;
 P_x is the probability of damage to the structure;
 L_x is the consequent loss.

In order to characterize the protection measures, IEC EN 62305-1 defines the Lightning Protection Levels (LPL)¹. Each Protection Level is related to a defined set of lightning current parameters and to the probability of a lightning strike being included in these parameters and therefore in the protection.

Four LPLs are defined, from LPL I (the most severe: the probability of occurrence of lightning with minimum or maximum current parameters outside the range of values defined for LPL I is less than 2 %) to LPL IV (the less severe).

IV. RISK EVALUATION FOR A PV SYSTEM

The general procedure described in the previous paragraph will now be adapted to the case of a PV System.

¹ The definition of IEC EN 62305-1 for LPL is: “number related to a set of lightning current parameters values relevant to the probability that the associated maximum and minimum design values will not be exceeded in naturally occurring lightning. Lightning protection level is used to design protection measures according to the relevant set of lightning current parameters.

The risk of loss of human life (Risk R_1) generally is not relevant for PV systems both in the case of PV modules on buildings and in the case of solar power plants (SPP). Fire hazard is in fact negligible (the PV structure is substantially incombustible), in solar power plants there is not presence of persons and PV modules on roofs are usually installed on small buildings (with low risk of direct flashes).

The risk of loss of service to the public (Risk R_2) is not considered because, generally, the out of service of a SPP doesn't influence the public service.

The only risk to be considered is therefore the loss of economic value (Risk R_4) with its risk components R_B , R_C , R_V , R_W , R_M and R_Z .

The risk components for PV modules on buildings are summarized in Fig. 1.

In this case the most relevant risk components are R_W , R_M and R_Z . To reduce the risk R_4 to a tolerable level the following protections could be adopted:

- a coordinated SPD system on the LV line entering the structure to reduce the components R_W and R_Z ;
- a coordinated SPD system on the DC line of the PV installation to reduce the component R_M .

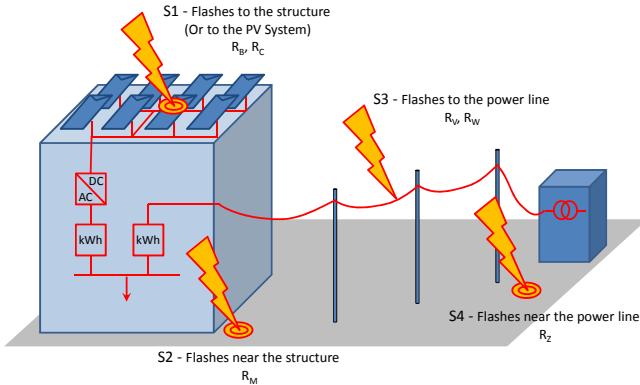

Fig. 1. Risk components for PV modules on buildings

Fig. 2 shows the risk components for a solar power plant. In this case, in addition to the above mentioned protection methods, an external LPS could be installed.

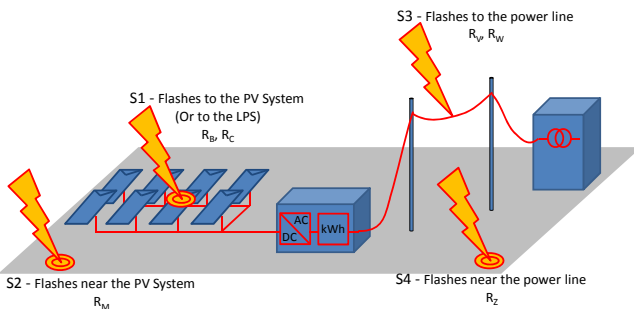

Fig. 2. Risk components for a solar power plant

V. SURGE OVERCURRENTS ON AC LINES

For direct and indirect lightning flashes to connected power lines, the surge overcurrents, according with IEC 62305-1, are given in TABLE 2 as a function of the lightning protection level (LPL) and the source of damage.

TABLE 2
EXPECTED SURGE OVERCURRENTS DUE TO LIGHTNING FLASHES ON LOW-VOLTAGE SYSTEMS

LPL	Direct and indirect flashes to the service		Flash near the structure
	Source of damage S3 (direct flash) Current shape 10/350 μ s [kA]	Source of damage S4 (indirect flash) Current shape 8/20 μ s [kA]	Source of damage S2 (induced current) Current shape 8/20 μ s [kA]
I	10	5	0.2
II	7.5	3.75	0.15
III-IV	5	2.5	0.1

On the basis of the values in TABLE 2 the correct SPDs can be chosen for installation.

VI. VOLTAGES INDUCED BY DIRECT FLASHES

In the case of direct flashes, the induced voltage U_{ip} can be calculated with the following approximated equation for a structure without shielding:

$$U_{ip} = k_c \times L_M \times \frac{di}{dt} \quad (2)$$

where:

k_c is the repartition coefficient of the lightning current amongst the air-termination/down conductors ($k_c = 1$ for one down conductor, $k_c = 0.5$ for two down conductors and $k_c = 0.44$ for 3 or more down conductors);

di/dt is the steepness of the subsequent stroke lightning current (200, 150 and 100 kA/ μ s as a function of the LPL), which is the worst case for the open circuit voltage in the induced loop;

L_M is the mutual inductance between the lightning current along the down conductor and the induced loop.

The mutual inductance can be calculated with equation (3) for flashes on an external isolated LPS:

$$L_M = 0.2 \times m \times \sin \alpha \times \ln \frac{f+b+1}{f+b} \quad (3)$$

where "m" is the width of the loop, to be equal to "e" for the differential mode calculation or to "e+d" for the common mode calculation. The reference configuration is showed in Fig. 3.

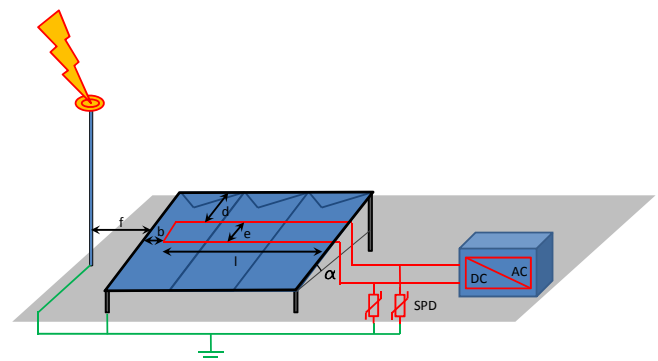

Fig. 3. Induced voltage for flashes to an isolated LPS

Considering an external LPS integrated into the PV metallic structure (natural LPS, Fig. 4), the lightning current is divided in three paths along the structure.

The higher induced voltage value is due to the current I_1 flowing near the longer side of the loop.

In this latter case, the mutual inductance is calculated with equation (4):

$$L_M = 0.2 \times l \times \ln \frac{d+e+r}{d+r} \quad (4)$$

where “r” is the equivalent radius of the metallic support of the PV system.

The short circuit current flowing in the loop, in the worst case, is the current associated to the first short stroke of the lightning current (200, 150 or 100 kA, depending on the considered LPL). The short circuit current can be calculated with equation (5), according to IEC 62305.

$$I_{sc} = k_c \times I \times \frac{L_M}{L_S} \quad (5)$$

Where L_S is the self-inductance of the loop, that can be calculated through equation (6):

$$L_S = 0.8 \cdot \sqrt{l^2 + e^2} - 0.8 \cdot (l + e) + 0.4 \cdot l \cdot \ln \left[\frac{\frac{2e}{r}}{1 + \sqrt{1 + \left(\frac{e}{l}\right)^2}} \right] + 0.4 \cdot e \cdot \ln \left[\frac{\left(\frac{2l}{r}\right)}{1 + \sqrt{1 + \left(\frac{l}{e}\right)^2}} \right] \cdot 10^{-6} \quad (6)$$

Under these assumptions, the calculated values of the induced voltage U_{ip} and of the short circuit current I_{sc} are reported in TABLE 3 for an unshielded loop with area of 50 m² and considering $k_c = 1$.

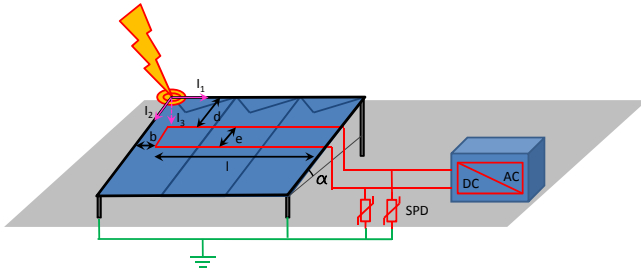

Fig. 4. Induced voltage for flashes to a natural LPS

Of course, different values could be calculated with different assumptions. However, the values in TABLE 3 are representative of the expected induced voltages on PV loops due to direct flashes to the structure. Moreover the induced voltage can be disregarded when the loop conductors are routed in the same cable and are twisted or are shielded.

TABLE 3
INDUCED VOLTAGE VALUES FOR UNIT LENGTH OF THE LOOP AND SHORT CIRCUIT CURRENT AS FUNCTION OF THE LPL

LPL	Induced voltage per unit length [kV/m]	Short circuit current (10/350 μs) [kA]
I	4	5
II	3	3.75
III-IV	2	2.5

VII. FLASHES NEAR THE PV SYSTEM

In the case of flashes near the PV system (source of damage S₂), the induced voltage U_{ip} , required by the risk component R_M , can be calculated using equation (2), with $k_c = 1$. The mutual inductance can be calculated with the following approximate equation:

$$L_M = 0.2 \times \frac{A}{s} \quad (7)$$

where A is the induced loop area and s is the distance between the point of strike and the center of the structure. The distance s can be calculated as a function of the rolling sphere radius R_{sp} and the structure dimensions:

$$s = (2 \times R_{sp} \times H - H^2)^{0.5} + \frac{L}{2} \quad \text{for } H < R_{sp} \quad (8)$$

$$s = R_{sp} + \frac{L}{2} \quad \text{for } H > R_{sp} \quad (9)$$

where H and L are the height and the width of the structure, respectively.

For this source of damage, the surge overcurrents, according with IEC 62305-1, are given in TABLE 1, column S2, as a function of the lightning protection level (LPL).

VIII. CONCLUSIONS

In the paper the procedures of risk assessment of the IEC 62305 series Standards are applied to PV systems to calculate the surge overcurrents for the different sources of damage.

The paper estimates overvoltages due to lightning discharges in the cases of direct flashes on the PV structure (source of damage S1) and flashes near the PV system (source of damage S2).

The criteria for SPD selection in the cases of direct and indirect lightning flashes to connected power lines (source of damage S3 and S4) are also showed.

The actual need of lightning protection measures has to be evaluated on the basis of the results of the risk analysis and of the protection costs.

In any case a good practice, as in all cases the induced overvoltages and overcurrents are related to the area of the loop, is to route the conductors in the same conduit or twist them together.

IX. REFERENCES

- [1] E. Collins, M. Dvorack, J. Mahn, M. Mundt, M. Quintana, “Reliability and availability analysis of a fielded photovoltaic system”, in *Proc. 34th IEEE Photovoltaic Specialists Conference (PVSC)*, 7-12 June 2009, pp. 2316 – 2321.
- [2] C. B. Rogers, “The protection of photovoltaic power systems from lightning”, in *Proc. 15th IEEE Photovoltaic Specialists Conf.*, May 1981, pp. 761–766.
- [3] D. C. Carmichael and G. T. Noel, “Development of low-cost modular designs for photovoltaic array fields”, *IEEE Trans. Power App. Syst.*, vol. PAS-104, no. 5, pp. 1005–1011, May 1985.
- [4] C. Zhang, J. Hu, Y. Tu, W. Sun, H. Jun Li and S. Wang, “Study of induced overvoltage on solar arrays”, in *Proc. 7th Asia-Pacific International Conference on Lightning (APL)*, 2011, pp. 852 – 857.

- [5] P. Vangala, M. Ropp, K. Haggerty, K. Lynn, W. Wilson, "Field measurements of lightning-induced voltage transients in PV arrays", in *Proc. 33rd IEEE Photovoltaic Specialists Conf.*, 2008, pp. 1 - 4.
- [6] *IEC Protection against lightning - Part 1: General principles*, IEC Standard 62305-1 Ed. 2.0, Dec. 2010.
- [7] *IEC Protection against lightning - Part 2: Risk management*, IEC Standard 62305-2 Ed. 2.0, Dec. 2010.
- [8] *IEC Protection against lightning - Part 3: Physical damage to structures and life hazard*, IEC Standard 62305-3 Ed. 2.0, Dec. 2010.
- [9] *IEC Protection against lightning - Part 4: Electrical and electronic systems within structures*, IEC Standard 62305-4 Ed. 2.0, Dec. 2010.
- [10] G.L. Amicucci, F. Fiamingo and T. Kisielewicz, "Risk assessment of photovoltaic installations, due to lightning, according to IEC 62305 - 2nd Edition", in *Proc. Lightning Protection (ICLP) 2012 International Conf.*, pp. 1-6.
- [11] J.C. Hernandez, P.G. Vidal and F. Jurado, "Lightning and Surge Protection in Photovoltaic Installations", *IEEE Trans. on Power Delivery*, vol. 23, no. 4, pp. 1961 - 1971, Oct. 2008.
- [12] C. Mirra, A. Porrino, A. Ardito and C. A. Nucci, "Lightning overvoltages in low voltage networks", in *Proc. 1997 CIGRE Conf.*, vol.2, pp. 19/1 - 19/6.
- [13] C. F. Barbosa, R. Pomponi and R. Tommasini, "SPD characteristics for equipment protection", in *Proc. 30th International Conference on Lightning Protection (ICLP2010)*, pp. 1041-1 - 1041-8, ISBN: 9788890551901.

X. BIOGRAPHIES



Enrico Pons received the master degree in electrical engineering and the Ph.D. degree in Industrial safety and risk analysis from Politecnico di Torino, Torino, Italy. He is currently a postdoctoral research fellow there. His research activities include power systems and electrical safety.



Riccardo Tommasini received the master degree and the Ph.D. in electrical engineering. He is currently assistant professor at Politecnico di Torino, Italy. His research activities include power systems and electrical safety. He is member of CEI, the Italian Electrotechnical Committee where he is working in the 31 Committee, dealing with the evaluation of hazards due to the risk caused by explosive atmospheres and in committee 81, dealing with the Protection against lightning.