

NanoMagnet Logic: an Architectural Viewpoint

*Original*

NanoMagnet Logic: an Architectural Viewpoint / Vacca, Marco; Graziano, Mariagrazia; Zamboni, Maurizio. -  
ELETTRONICO. - (2013). ( Workshop on Field-Coupled Nanocomputing Tampa, Florida 2013).

*Availability:*

This version is available at: 11583/2510679 since:

*Publisher:*

*Published*

DOI:

*Terms of use:*

This article is made available under terms and conditions as specified in the corresponding bibliographic description in the repository

*Publisher copyright*

(Article begins on next page)

# NanoMagnet Logic: an Architectural Viewpoint

M. Vacca, M. Graziano and M. Zamboni

Department of Electronics and Telecommunications, Politecnico di Torino, Italy

Email: marco.vacca@polito.it, mariagrazia.graziano@polito.it, maurizio.zamboni@polito.it

**Abstract**—Among the possible implementation of Field-Coupled devices NanoMagnet Logic is attractive for its low power consumption and the possibility to combine memory and logic in the same device. However, the nature of these technologies is so different from CMOS transistors that the implications on the circuit architecture must be taken carefully into account.

In this work we analyze the most important issues related to the design of complex circuits using this technology. We discuss how they influence the architectural level. We propose detailed solutions to solve these problems and to improve the overall performance. As a result of this analysis the type of circuits and applications that constitute the best target for this technology are identified. The analysis is performed on NanoMagnet Logic but the results can be applied to any QCA technology.

## I. INTRODUCTION

Field-Coupled devices like Quantum dot Cellular Automata (QCA) are based on a completely different approach with respect to CMOS transistors [1]. In this technology, bistable cells are used to represent the logic values '0' and '1'. Logic computation is obtained through coupling among neighbor cells [2]. NanoMagnet Logic is an implementation of the QCA principle, where single domain nanomagnets with two stable states are used as basic cells [3]. Their main advantage is the low power consumption and the possibility to combine memory and logic in the same device [4]. To switch magnets from one state to the other, a clock mechanism is necessary: Magnets are forced in an intermediate unstable state through an external stimulus, while when this stimulus is removed magnets reorder themselves following the input magnet. Clock can be implemented using a current generated magnetic field [5], through a spin-torque coupling in multilayered structures [6] or applying an electric field on multiferroic nanomagnets [7]. Since the number of magnets that can be cascaded is low [8], a multiphase clock must be used. Three clock signals with a phase difference of 120 degrees (Figure 1.A) are applied to small circuit areas called clock zones. Every zone is composed by a limited number of magnets. In each time step (Figure 1.B) when magnets of a clock zone are switching (SWITCH state), magnets in their left are in the HOLD state and act like an input, while magnets on the right are in the RESET state and have no influence. In this way signals propagate through the circuit without errors [9].

Due to this clock system every group of three consecutive clock zones have a delay of one clock cycle and are therefore equivalent to a CMOS register. This means that a NML wire, composed by many clock zones, has a delay of many clock cycles, leading therefore to an intrinsic pipelined nature. This has a huge impact on the circuit architectures. In this work

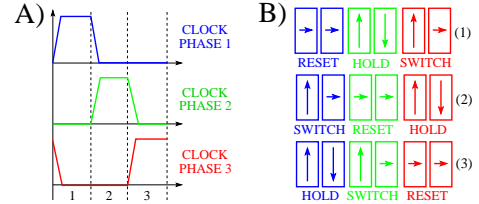

Fig. 1. A) 3-phase clock signals. B) Signal propagation in clock period.

we analyze the consequences of this behavior, the problems that it generates and the way to solve them and to improve circuit performance. On the basis of our conclusions we can understand what kind of circuits and applications are best suited for NanoMagnet Logic and Field-Coupled devices.

## II. PIPELINING AND INTERCONNECTIONS

We refer to Figure 2 to support the discussion in this section. It shows as example a 2 bits Multiply and Accumulate unit (MAC) made by a multiplier and an adder, where the output of the adder is connected to one of its inputs. The MAC is the most important unit of Digital Signal Processors (DSP), and is then worth studying as frequently used in many applications. The pipelined nature of this technology has two main consequences: The so-called “Layout=Timing” problem [10] and the feedback problem [11]. The “Layout=Timing” problem means that, if the input wires of a logic gate have a different length in terms of clock zones, input signals of a logic gate can have a different propagation delay and the logic operation is not correct. This problem is reduced if a regular layout is used. In Figure 2 the layout is obtained considering clock zones made by parallel wires (zones are in the picture separated by the vertical stripes). here we consider this case as it is currently the only layout experimentally verified for NanoMagnet Logic [4]. Using this organization the “Layout=timing” problem is automatically solved, as all signals are affected by the same delay in terms of number of clock zones they traverse. In case another clock zone organization is used, this problem remains and requires careful layout: in case of complicated circuits this comes at the cost of a great area expense.

The feedback problem instead is a problem that exists also in CMOS, for example in Superscalar Microprocessors. Due to the pipelined nature of this technology a new data can be sent every clock cycles. For example every adder in Figure 2 can receive a new input every clock cycle. However the second input of the adder is also its own output. The feedback of output toward input requires many clock cycles to propagate

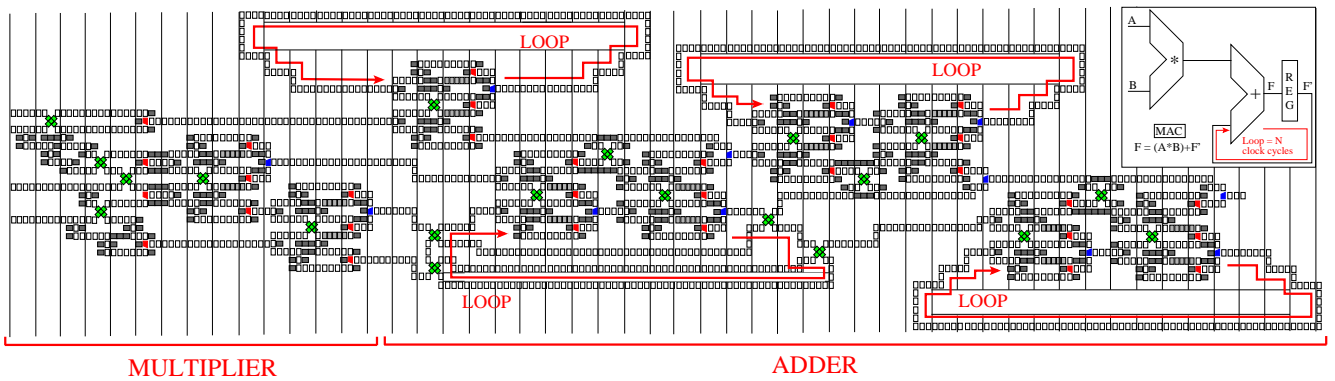

Fig. 2. Circuit example: 2 bits Multiply and Accumulate (MAC) unit.

and this has consequences in terms of performance. When a data is sent to the circuit the result is evaluated and it propagates back to the input of the adder. The signal requires  $N$  clock cycles to propagate through the loop, as  $N$  is the number of clock phases it traverses. As a consequence, if a new data is sent only after one clock cycle, as it would be natural to do, the feedback signal is still propagating through the circuit. The addition is therefore performed in this case between the new data and the results of the addition calculated  $N-1$  clock cycles before and the obtained value is not correct. In order to synchronize signals, inputs must be fed to the circuit every  $N$  clock cycles, where  $N$  is delay of the longest loop of the circuit, and kept frozen in the meantime. The consequences are that circuit throughput is reduced of  $N$  times, severely reducing performance.

To solve this problem one possible solution to exploit interleaving to maximize performance. The MAC unit here described is the key-unit in linear filtering operations for signal analysis, so it is a good example to use to describe the interleaving technique. Running  $N$  linear filtering operations permits to keep the pipeline full. Every linear filtering operation is composed by many “multiply and accumulate” operations. At the first clock cycle the first data of the first linear filtering operation (OPA-1) is sent. At the second clock cycle the first data of the second linear filtering operation (OPB-1) is sent. In this case the operation is correct because data are sent every clock cycle but there is no data dependency between them. After  $N$  clock cycles the second data of the first linear filtering operation (OPA-2) is sent, and so on. The distance among two data that are part of the same linear filtering operation is therefore  $N$  clock cycles, so that signals are correctly synchronized. Running  $N$  operations in parallel and interleaving them allows to keep the pipeline always full and to maximize the throughput.

Another problem is the impact of interconnections. In the circuit in Figure 2 a large part of the area is filled by wires, wasting area and increasing power consumption. To reduce the impact of this problem it is important to design circuit using systolic like architectures [12], that have a regular layout and avoid long interconnections wires.

*Conclusions.* The discussion here presented leads to two

important results. First, the delay of loops can be very high so we need massive interleaving to maximize throughput, and, second, systolic-like architectures are necessary to minimize interconnections. From this two points we can say that Field-Coupled devices are best suited for Massive Data Analysis applications, like Digital Signal Processors, where it is possible to take advantage of a parallel systolic architectures and massive parallelism can be used to maximize the circuit throughput. General purpose applications, like microprocessors, are instead not well suited for this technology because they can suffer from a severe penalty in the performance.

## REFERENCES

- [1] C.S. Lent, P.D. Tougaw, W. Porod, and G.H. Bernstein. Quantum cellular automata. *Nanotechnology*, 4:49–57, 1993.
- [2] A.I. Csurgay, W. Porod, and C.S. Lent. Signal processing with near-neighborcoupled time-varying quantum-dot arrays. *IEEE Transaction On Circuits and Systems*, 47(8):1212–1223, 2000.
- [3] W. Porod. Magnetic Logic Devices Based on Field-Coupled Nanomagnets. *Nano & Giga*, 2007.
- [4] M.T. Niemier, G.H. Bernstein, G. Csaba, A. Dingler, X.S. Hu, S. Kurtz, S. Liu, J. Nahas, W. Porod, M. Siddiq, and E. Varga. Nanomagnet logic: progress toward system-level integration. *J. Phys.: Condens. Matter*, 23:34, November 2011.
- [5] M.T. Niemier, X.S. Hu, M. Alam, G. Bernstein, M. Putney W. Porod, and J. DeAngelis. Clocking Structures and Power Analysis for nanomagnet-Based Logic Devices. In *Int. Symp. on Low Power Electronics and Design*, pages 26–31, Portland-Oregon, USA, 2007. IEEE.
- [6] J. Das, S.M. Alam, and S. Bhanja. Low Power Magnetic Quantum Cellular Automata Realization Using Magnetic Multi-Layer Structures. *J. on Em. Sel. Topics in Circ. and Sys.*, 1(3), September 267-276.
- [7] M. S. Fashami, J. Atulasimha, and S. Bandyopadhyay. Magnetization Dynamics, Throughput and Energy Dissipation in a Universal Multiferoic Nanomagnetic Logic Gate with Fan-in and Fan-out. *Nanotechnology*, 23(10), February 2012.
- [8] G. Csaba and W. Porod. Behavior of Nanomagnet Logic in the Presence of Thermal Noise. In *International Workshop on Computational Electronics*, pages 1–4, Pisa, Italy, 2010. IEEE.
- [9] M. Graziano, M. Vacca, A. Chiolerio, and M. Zamboni. A NCL-HDL Snake-Clock Based Magnetic QCA Architecture. *IEEE Transaction on Nanotechnology*, (10):DOI:10.1109/TNANO.2011.2118229.
- [10] M. Graziano, M. Vacca, D. Blua, and M. Zamboni. Asynchrony in Quantum-Dot Cellular Automata Nanocomputation: Elixir or Poison? *IEEE Design & Test of Computers*, 2011.
- [11] M. Vacca, M. Graziano, and M. Zamboni. Asynchronous Solutions for Nano-Magnetic Logic Circuits. *ACM Journal on Emerging Technologies in Computing Systems*, 7(4), December 2011.
- [12] M. Crocker, M. Niemier, and X.S. Hu. A Reconfigurable PLA Architecture for Nanomagnet Logic. *ACM Journal on Emerging Technologies in Computing Systems*, 8(1), February 2012.