

POLITECNICO DI TORINO
Repository ISTITUZIONALE

Experimental method for investigating air leakage in rodless cylinders.

Original

Experimental method for investigating air leakage in rodless cylinders / Belforte, Guido; Ivanov, Alexandre; MANUELLO BERTETTO, Andrea; Mazza, Luigi. - In: EXPERIMENTAL TECHNIQUES. - ISSN 0732-8818. - STAMPA. - (2013).
[10.1111/ext.12039]

Availability:

This version is available at: 11583/2510129 since: 2016-02-16T16:11:29Z

Publisher:

SEM

Published

DOI:10.1111/ext.12039

Terms of use:

This article is made available under terms and conditions as specified in the corresponding bibliographic description in the repository

Publisher copyright

(Article begins on next page)

EXPERIMENTAL METHOD FOR INVESTIGATING AIR LEAKAGE IN RODLESS CYLINDERS

G. Belforte (*), A. Ivanov (*), A. Manuello Bertetto (**), L. Mazza (*)

(*) Department of Mechanical and Aerospace Engineering

Politecnico di Torino, TORINO, ITALY

(**) Department of Mechanical, Chemical and Materials Engineering

Università degli Studi di Cagliari, CAGLIARI, ITALY

Abstract

The paper presents a test method for evaluating air leakage in rodless cylinders with longitudinal slot and sealing band. To this aim a specific test rig was developed in order to carry out leakage tests under different operating conditions. Specifically, the performance of the sealing system consisting of the band, seal and barrel is analyzed, identifying the critical conditions and factors that influence operation. Particular importance was assigned to selecting band and seal cross-sections in order to minimize leakage and thus limit energy consumption. A final rodless configuration with considerably reduced leakage was proposed.

Keywords: pneumatics, pneumatic cylinders, rodless cylinders, seals

INTRODUCTION

Rodless cylinders are specialized pneumatic components capable of moving slides through strokes that may be as much as several meters long, but feature a more compact design than conventional cylinders such as single and double rod types. While there are a number of possible rodless configurations, including sealing band cylinders with slotted barrel, cable cylinders, magnetically coupled cylinders, recirculating band cylinders, etc., the type with a longitudinal slot on the barrel and a flexible sealing band has been most widely used, chiefly because its robust construction provides reliable operation. The slot along the entire length of the barrel makes it possible to connect the external slide to the piston inside the barrel, transmitting motion to the load to be moved.

These actuators, however, have the disadvantage of being rather complex and costly, as their construction involves a high degree of precision for a number of components. This is true both of the guide bearings for

the piston-slide system, which must be capable of ensuring motion with little machining gap and withstanding fairly sizable bending and torsional moments, and of the members that seal and limit leakage from the cylinder. Of the latter, the sealing mechanism provided by the band-slot and piston-seal system is particularly important.

In general, sealing in pneumatic actuators has always been a major focus for both researchers and manufacturers of actuators and seals. The cylinder's general performance, in fact, hinges on the dynamic seals' operation, in terms of both sealing and friction. Many investigations have thus analyzed the tribological parameters of the seal-barrel interface and the most influential operating conditions, viz., grease and lubrication conditions, seal/counterpart material, seal cross-sectional geometry, and surface finish. Belforte et al.^{1, 2, 3} developed a method for evaluating pneumatic actuator service life and performance, with particular reference to piston and rod seals. Tests demonstrated the importance of lubrication conditions and of seal geometry and materials, while an extensive failure analysis and classification of damage modes made it possible to establish preventative maintenance procedures. Contact and lubrication issues with individual seals were addressed by Muller⁴, Haas⁵, Wangheneim⁶, Belforte et. al⁷, Prati^{8, 9} and Visconte et. al¹⁰: film thickness, leakage, friction and contact pressure were calculated and compared, highlighting the importance of seal ring profile and rheological data. The importance of seal geometry was analyzed in Calvert et al.¹¹ and Belforte et al.¹², who presented methods for redesigning and optimizing seal cross-section geometry to improve tribological performance. Surface finish was analyzed by Etsion et al.¹³ in order to determine the importance that texturing the surface in contact with the elastomer has in reducing friction.

The sealing capacity of rodless actuators is essential to their correct operation, especially in automatic applications that involve continuous positioning. Drukanov et. al¹⁴, Thomas et. al¹⁵ and Fok et. al¹⁶ show that the problem of friction and, in particular, of sealing is fundamental in achieving effective control of rodless pneumatic actuators. Specifically, it was found that leakage significantly influences flow rates in the cylinder chambers, which must be known in determining cylinder performance (position, velocity, force).

This paper presents a test method for evaluating air leakage in rodless cylinders with longitudinal slot and sealing band. In particular, the method analyzes the sealing capacity of the band-seal-barrel system in order to identify the critical conditions and factors that influence operation. For this purpose, an initial series of tests was carried out on commercial cylinders to evaluate the influence that operating conditions (chamber pressure, longitudinal position of the slide along its stroke, load applied to the slide, band tension) have on leakage flow rate. A second series of tests was then conducted with an eye to reducing the leakage flow rate,

and hence energy consumption due to leakage, through appropriate changes in band type, seal cross-section and seal material. Tests were carried out in dry condition in order to enhance leakage effects taking into account that the presence of grease enables better sealing conditions. Of course in the actual use the cylinder will work with grease (lubricated for life cylinder).

CYLINDER UNDER TEST AND COMPONENTS

The cylinder under test is a rodless pneumatic cylinder of the type pictured in Figure 1. The barrel consists of aluminum profiles closed by means of two end caps whereby the actuator is secured and the chambers can be supplied. As shown in the figure, the slide runs lengthwise along the top of the barrel to move the external load. The external slide is connected to the piston inside the barrel by means of a longitudinal slot in the barrel's aluminum body.

Figure 2 shows longitudinal and cross sections through the cylinder under test, depicting the



Figure 1 Rodless pneumatic actuator under test.

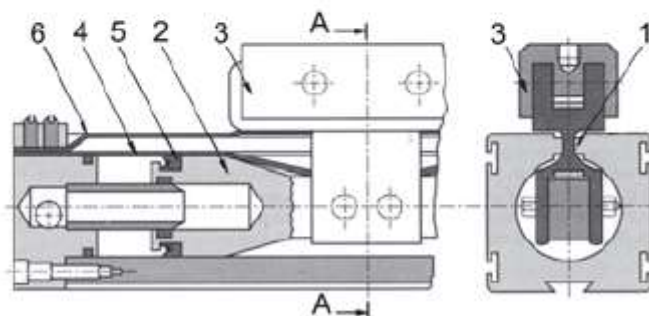

Figure 2 Sections through slotted barrel type rodless pneumatic actuator.

lengthwise slot (1) whereby the piston (2) can be connected to the external slide (3) to which the load will be secured. Sealing is accomplished by means of an internal metal band (4) which closes off the slot in the area which is not engaged by the piston; the band then enters the piston, passing internally. The piston is provided



with two lip seals (5) which isolate the two actuator chambers. These seals also contact the inner surface of the band. As the cylinder moves, the flexible band adapts to the changing positions of the piston and slide. A second, outer band (6) covers the slot to prevent the ingress of impurities and foreign bodies and thus ensure that the actuator can continue to operate correctly.

As can be seen from an examination of this type of construction, the areas of contact between band and barrel and between seals and band are extremely important, as the actuator's sealing effectiveness and thus its ability to limit compressed air leakage to the exterior depend on these areas.

Another far from negligible aspect is that of the friction forces resulting from the interaction between the moving parts (the seals and piston-slide system) and the sealing band.

The test bench and the tests that were carried out were designed to evaluate the actuator's sealing performance under different operating conditions. To

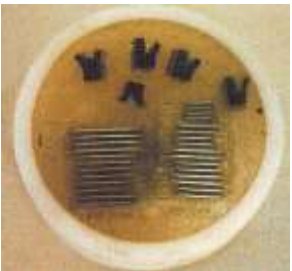
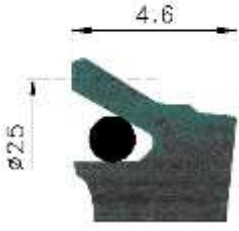
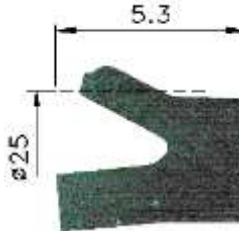
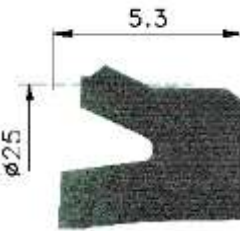
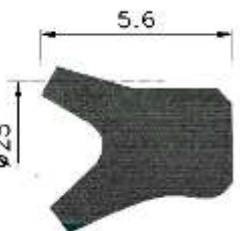
Table 1: Material under test – cylinder, seals and bands

Cylinder bore	 <p>Seals and bands embedded in resin test specimen</p>		
<i>Material:</i> Anodized aluminium			
<i>Roughness:</i> $Ra \approx 0.6 \mu m$			
Piston seals			
$S_{1,OR}$	S_2	S_3	S_4
			
Polyurethane	NBR	NBR	NBR
Band	B_1		B_2
<i>Material:</i> Stainless steel <i>Roughness:</i> $Ra \approx 0.2 \mu m$			

this end, a number of operating parameters were analyzed (working pressure, slide loads, band tension, etc.) along with geometric magnitudes (actuator bore, longitudinal position of the slide) and the different possible configurations for the parts of the actuator which were regarded as fundamental: specifically, two types of sealing band and three types of piston seal were considered.

Table 1 shows the main characteristics of the cylinders under test, the cross-section of the tested seals, band cross-sections and materials. The cylinder bore used as a reference in carrying out tests with different seal and band types was 25 mm.

Images of the seal and band cross-sections were obtained under an optical microscope. For this purpose, a test specimen was prepared by embedding cut sections of seals and bands in a resin block (see Table 1). The test specimen surface was then ground and polished before proceeding with optical measurements; the latter enabled to measure with accuracy geometric dimensions of seals and bands under test.

The seals selected for testing differed in geometry, material and lip configuration, where the lip referred to is the outer sealing lip in contact with the band and barrel. Seal $S_{1,OR}$ consists of polyurethane and features an O-ring energized rounded sealing lip; the material and the internal O-ring ensure good radial stiffness, which guarantees sealing at low pressures. The O-ring is not integrated with the lip seal or supplied as standard, but was added subsequently by the cylinder manufacturer. Seal S_2 also features a rounded lip, though with a larger fillet radius than that of the first seal, and a lower radial stiffness because the NBR material used for this seal is softer than polyurethane. Seals S_3 and S_4 also consist of NBR and feature a sealing lip with sharp edges. In the case of seal S_4 , the thick cross-section and lip result in a higher radial stiffness than seals S_2 and S_3 , though the material is the same.

A characteristic cross-sectional dimension is shown for each seal.

Two types of sealing band were tested, both consisting of the same material with the same surface finish. The geometric characteristic used to identify them is edge thickness, which is 60 μm for band B_1 and 30 μm for band B_2 . Moreover, the thicker band B_1 has a square edge, while the thinner band B_2 has a rounded edge.

The nominal assembly configuration used in the commercial cylinders under test consisted of band B_1 and seal $S_{1,OR}$.

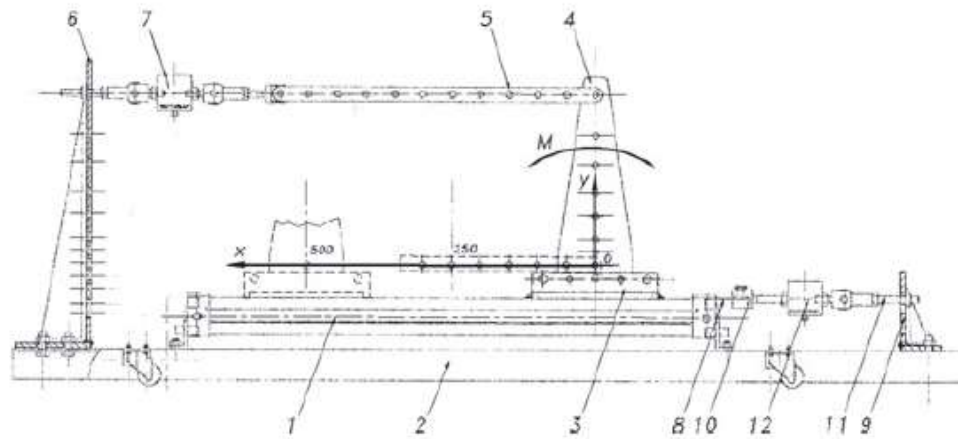

Figure 3 Test bench schematics.

EXPERIMENTAL SET-UP AND TEST CONDITIONS

A test bench was designed and constructed in order to evaluate rodless cylinder performance. The bench makes it possible to determine actuator sealing while varying operating conditions, viz., working pressure, slide load, band tension, actuator bore, longitudinal position of the slide along its stroke, and type of flexible band and piston seal. In particular, the bench was designed for cylinders with a stroke of 500 mm and bores ranging from 25 to 63 mm. The bench features mechanical means for blocking the slide at different positions along its stroke, as well as means for tensioning the sealing band: it was thus possible to establish varying pitch moments on the slide and varying levels of tension on the band.

The bench is shown in Figure 3. Cylinder under test (1) is secured to horizontal base (2). Slide (3) can be blocked along its stroke by means of a system consisting of bracket (4), which is positively connected to the slide, shaft (5), and upright (6), which is positively connected to base (2). Load cell (7) measures the force at the axis of shaft (5), thus making it possible to calculate moment M applied to the slide-piston assembly. A series of holes in bracket (4) and upright (6) can be used to vary the position of shaft (5) along the y axis; by varying the lever arm for any given pressure acting on the cylinder piston, this in turn varies moment M . The shaft in the $y=0$ position is represented with a dashed line in Figure 3; this position was determined in order to produce a moment M on the slide equal to the permissible moment for the cylinder under test when the pressure in the latter is 6 bar. The upper position y , with shaft and load cell represented with a solid line, corresponds to the condition for the permissible moment at a pressure of 2 bar; using the other holes produces intermediate moment conditions. Slide position along the x axis can be varied by means of the holes in shaft (5).

The tension on band (8) is adjusted by means of the loading system installed between the band and angle bracket (9) positively connected to base (2). The end of the band is held in clamp (10), while the force is adjusted by means of screw (11) and measured by load cell (12). The band under test is longer than that commonly used in the actuator to ensure that it protrudes from one end of the cylinder and can thus be clamped.

Figure 4a is a photograph of the test bench, showing the actuator installed on the base with the slide blocked in an intermediate position by means of the bracket and horizontal shaft. Figure 4b shows a detail of the bench's band tensioning system, showing the adjusting screw, the load cell and the band clamp.

The pneumatic circuit used to measure the cylinder's leakage flow rate is shown in Figure 5. Measurements are carried out individually for each of the two cylinder chambers. The circuit consists of a main upstream line and two secondary lines L_A and L_B supplying the cylinder under test (C). The main line contains regulator (R_P) and line gauge (M_L) used to regulate circuit pressure. The 3/2-way shutoff valve (S) isolates the downstream circuit from the upstream line, while uni-directional resistance (R) enables the circuit to be pressurized gradually. Downstream of the resistance (R), the circuit splits into two lines: L_A for supplying the cylinder chamber via float type flowmeter (F) and measuring leakage through the cylinder chamber, and line L_B for supplying the cylinder chamber directly. The latter line makes it possible to carry out actuator setup and adjustment operations without passing through the flowmeter. Valves V_1 and V_2 are used to pressurize or exhaust

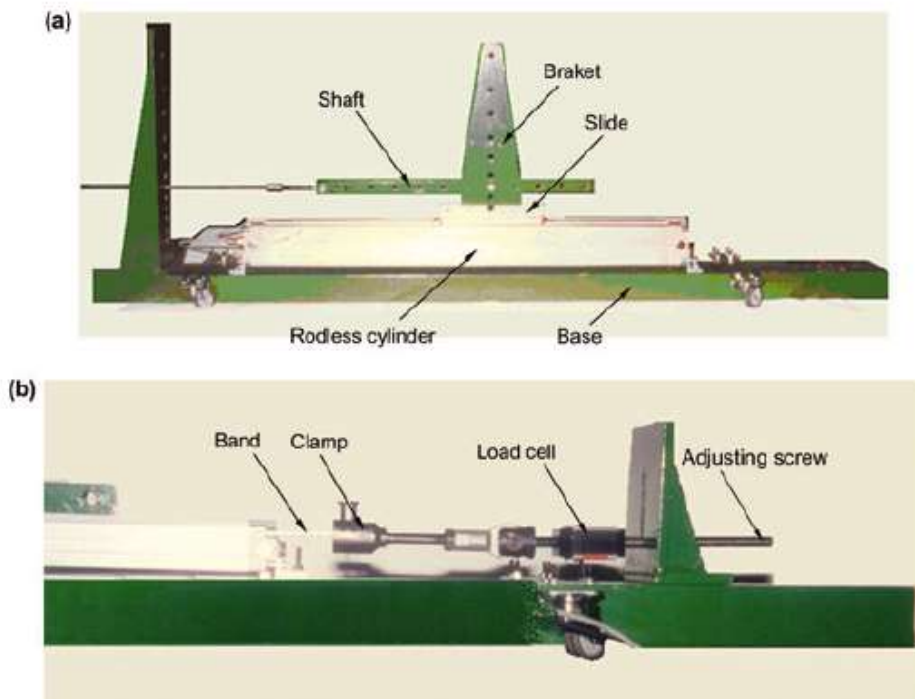

Figure 4 Test bench. (a) Bench assembly and (b) detail of band tensioning system.

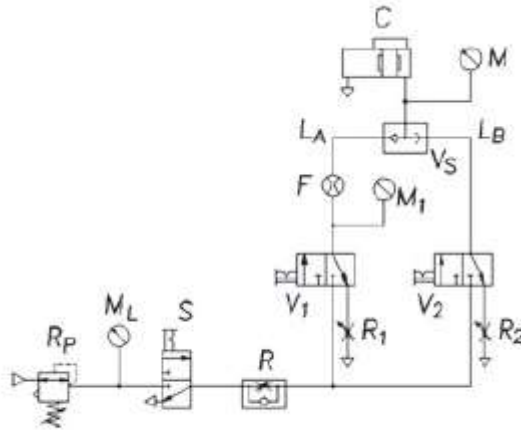

Figure 5 Test bench pneumatic circuit.

the two lines, while pressure can also be exhausted gradually by means of restrictor valves R_1 and R_2 . The circuit is completed by valve V_S and gauges M and M_1 used to read the pressures upstream of the cylinder under test and of the flowmeter respectively.

Leakage flow rate was determined with the slide blocked along its stroke, supplying the two opposing chambers in succession. Tests were conducted at pressures of 2, 4 and 6 bar. The actuators used were all produced by the same manufacturer, and had bores ranging from 25mm to 63mm and a 500mm stroke. Tests were carried out with the slide at different positions x along its stroke, different moments M applied to the slide, and different band tension levels. For the 25mm bore cylinder, tests were performed with several types of piston seal and bands as shown in Table 1. Cylinder are greased for life type. Anyway test were carried out in dry condition in order to avoid any influence of the grease on the sealing behaviour.

EXPERIMENTAL RESULTS

Results are illustrated below for the leakage flow rates determined under actual operating conditions while varying the operating parameters indicated in Table 2. Tests evaluated the effect of each parameter individually and its influence on performance. Leakage flow rate is limited both by the band's capacity to provide a seal against the slot on the barrel, and the piston seal-band system's sealing capacity. The proposed method and tests sought to separate the contributions to sealing made by the band and the piston seal. The results shown are average values for tests carried out on a sample of at least 3 cylinders for each bore dimension. Measurements were repeated 3 times for each of the 5 defined position.

The first results shown (Figures 6-10) are for tests carried out on commercial cylinders (assembly configuration $B_I-S_{I,OR}$ in Table1).

By way of example, Figure 6 shows leakage flow rate versus the slide's position along its stroke at different supply pressures for the 25mm bore actuator. As can be seen, the leakage flow rate increases slightly as the slide is moved farther along its stroke: this is

Table 2: Operating parameters under test

Cylinder dimensions	$\phi = 25, 40, 50, 63$ mm bore 500 mm stroke		
Slide position along the stroke	$x = 0, 100, 200, 300, 400, 500$ mm		
Test pressure	$p = 2, 4, 6$ bar		
Moments (applied to the cylinder slide)		$\phi 25$	$\phi 50$
	M_X	4 Nm	122 Nm
	M_{MIN}	4.1 Nm	40.7 Nm
Band tension	$T = 0, 5, 10, 15$ N		

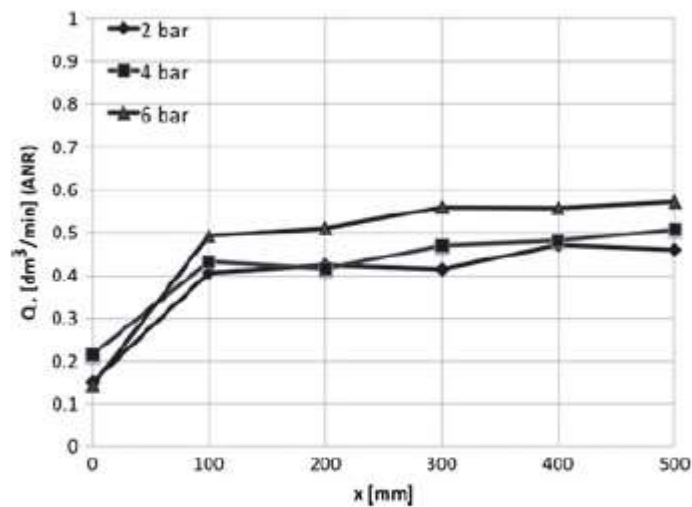

Figure 6 Leakage flow rate versus slide position.

because a longer length of the internal sealing band is thus exposed to pressurized fluid in the cylinder chamber; the increase in the portion of the band that is not engaged by the piston thus has a negative effect on leakage flow rate. As can also be seen, leakage flow rate increases along with the pressure in the chamber (upstream of the leak section). This increase, however, is less than proportional to the ratio of two consecutive upstream pressures. This indicates that the ability of the band and seals to close off the leak area has a compensating effect as pressure increases.

The effect of actuator size on leakage flow rate was evaluated by testing actuators with different bores at varying supply pressures. Test results are shown in the graph in Figure 7 the shown results are an average of the leakage values measured with the slide at the 5 defined positions along the stroke, for each cylinder size and pressure. As regards the increase in leakage flow rate with pressure, the considerations made above continue to apply. Bore has a significant effect: for small bores, the leakage flow rate is far greater than that found for larger bores. This is

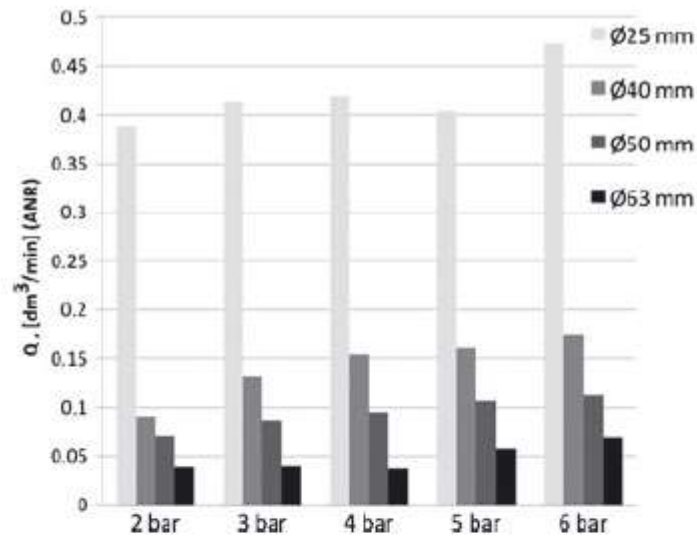

Figure 7 Leakage flow rate versus supply pressure.

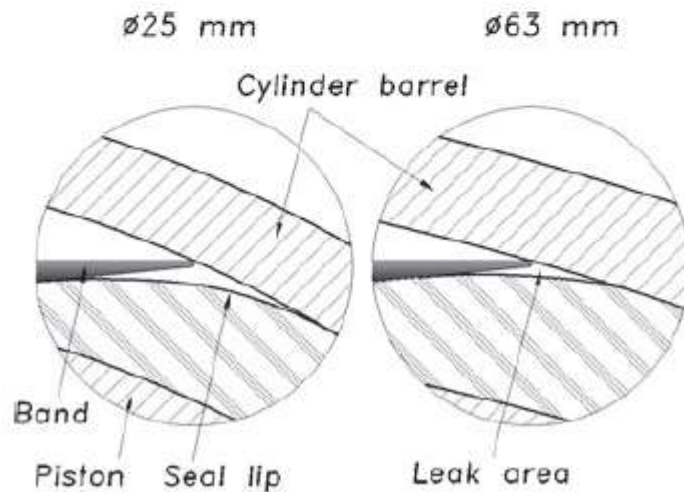

Figure 8 Leak area for different actuator bores.

attributed to the cylinder's radius of curvature and the fact that with smaller bores the piston seal is less able to conform to the band and the barrel. The sketch in Figure 8 illustrates this behavior for 25mm and 63mm bore cylinders: as band thickness is constant, the leak area between seal and barrel is larger for the smaller bore.

In order to evaluate the influence on leakage flow rate, of both external load and moment, a series of tests were carried out on 25mm and 50mm actuators. Maximum applied moment M_{MAX} was the maximum permissible value declared by the manufacturer for the cylinders in question, i.e., 12.4 Nm for the 25mm bore cylinders and 122 Nm for the 50mm bore cylinders. The minimum applied moment was: $M_{MIN} = \frac{1}{3} M_{MAX}$.

Figure 9 shows leakage flow rate for different slide positions x along the stroke for the two applied moments M_{MAX} and M_{MIN} during tests

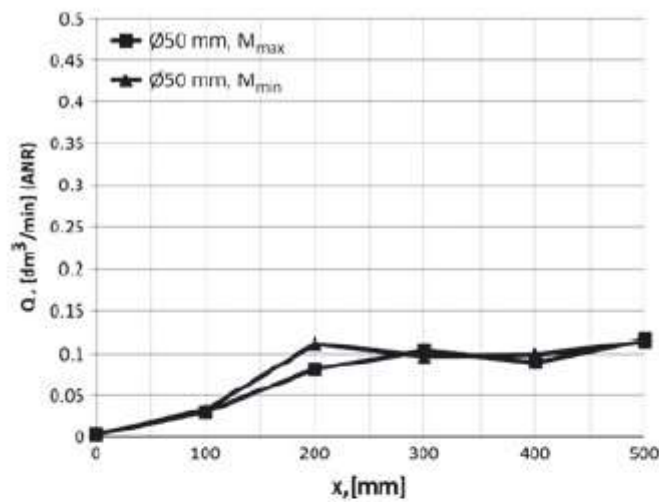

Figure 9 Leakage flow rate with moment applied to cylinder slide.

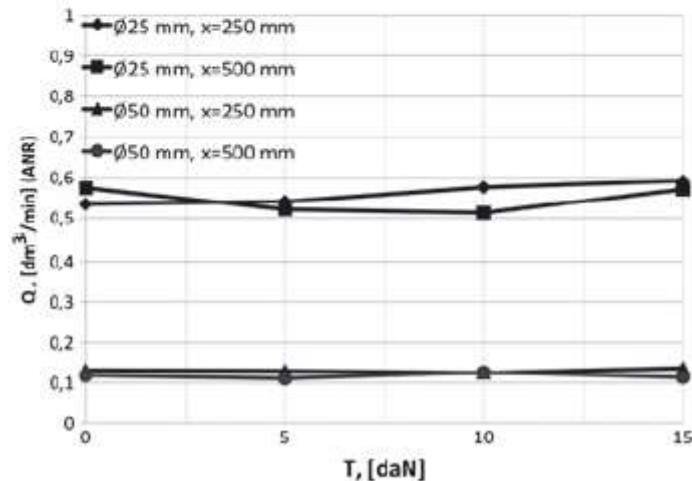

Figure 10 Leakage flow rate versus sealing band tension.

on 50mm bore actuators. As can be seen, applying moment M does not cause a significant variation in the system's sealing capacity. The piston-slide unit's guide system is thus sufficiently stiff and its amount of

machining gap is small enough not to influence the air leak area at the seal-band-barrel interface when an external load is applied.

To evaluate the effect of band tension, tests were carried out with a tensile load on the band ranging from 0 to 15 daN. Leakage flow rates were measured in two slide positions, viz., $x=250, 500$ mm on 25 mm and 50 mm bore cylinders with a working pressure of 6 bar. As Figure 10 shows, this parameter also has no significant influence on sealing capacity. By contrast, band tension has a negative influence on actuator friction. Because of the way the actuator is manufactured, the band crosses the piston and rests on the latter's seals: an increase in tension results in greater piston seal compression. By means

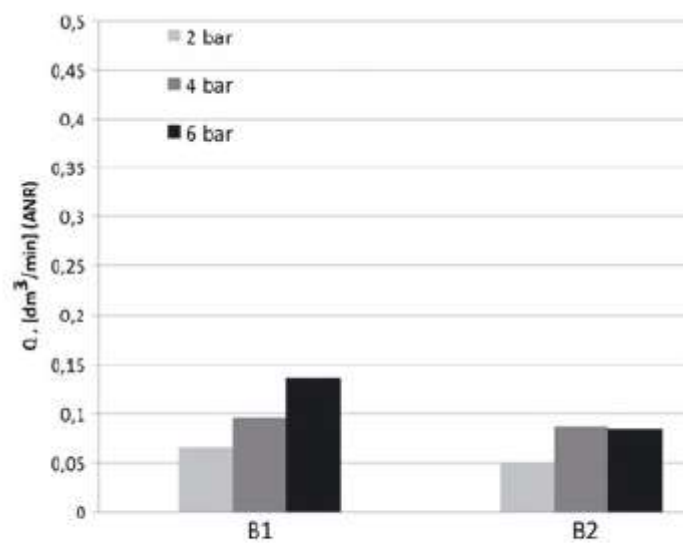

Figure 11 Leakage flow rate of pneumatic actuator without piston (band alone).

of the test bench, it was possible to evaluate piston breakaway pressure as a function of band tension, finding that breakaway pressure increased by an average of 30% as band tension rose from 0 N to 15 N. It is this entirely reasonable to use a minimum tension such as that which can be achieved by installing the band manually.

The tests conducted up to this point evaluated the performance of commercial cylinders while varying a number of operating parameters. Analysis and interpretation of results made it possible to advance a hypothesis regarding the location of the leak area at the seal-band interface. A series of specific tests were thus carried out with an eye to reducing this leak area and, consequently, limiting air leakage losses. The different band types, seal cross-sections and seal material indicated in Table 1 were used in these tests.

In the first tests, the cylinders' internal piston-slide assemblies were removed from the 25 mm bore commercial barrels used in the previous tests in order to evaluate the sealing capacity of the band alone.

Figure 11 shows leakage flow rate at different supply pressures with bands B_1 and B_2 . The type of band can be seen to have an influence that depends chiefly on the thickness and shape of the band's edge. With its thin, rounded edge, band B_2 ensures less leakage than band B_1 ; this can be attributed to the fact that band B_2 is more flexible and better able to conform to the barrel and slot surface. For both bands, the leakage flow rate increases along with pressure, but does so more noticeably than it did for the complete cylinder tested earlier: this indicates that the band is less effective at closing off the leak area than the seal.

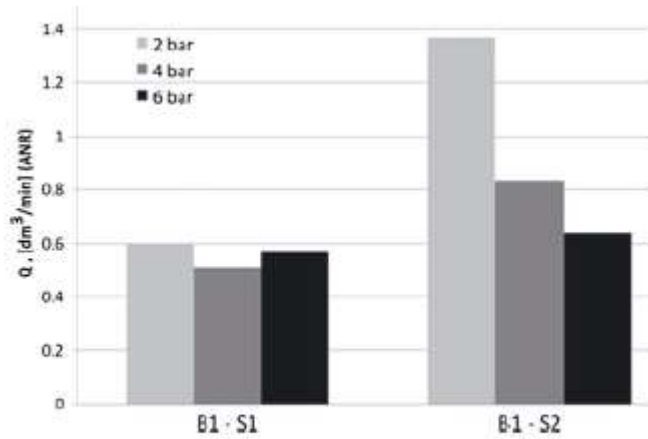

Figure 12 Leakage flow rate with seals S_1 and S_2 and thick-edged band B_1 .

The flow rate measured with the band alone can be regarded as a minimum value beneath which air leakage cannot be limited. Installing the piston and the seals will undoubtedly introduce a leakage flow rate which will be added to that associated with the band alone.

Following, tests were then carried out to evaluate the effects of each seal type with any given band. Seal $S_{1,OR}$ was used without O-ring (S_1) for uniformity of comparison with the other lip seals. Tests were performed using commercial 25 mm bore barrels at different cylinder pressures. The results shown are the average leakage flow rates measured with the -slide at the 5 defined positions along the stroke as specified in Table 2. Figure 12 compares sealing capacity with band B_1 and seals S_1 and S_2 . With the same band, better leak containment is achieved with seal S_1 ; the shape of the lip is clearly decisive in determining the size of the leak area at the seal-band-barrel interface (see Figure 8). Seal S_1 has a thinner lip and smaller radius than S_2 , characteristics that have a significant influence on the seal's ability to reduce the leak area at the interface with the band and barrel. By contrast with the results obtained with the band alone, leakage flow rate dropped as working pressure increased during tests with a seal (an effect that was more pronounced in the case of seal

S_2). This can be attributed to the seal lip's ability to be energized by pressure and thus reduce the leak area. This compensation effect is more evident for seal S_2 , as its NBR material is softer than polyurethane. Similar behavior was found when using the same seals with band B_2 : once again, seal S_1 performed better (Figure 13). In this case, leakage was lower than it was with the thicker band B_1 , reinforcing the hypothesis regarding the leak area illustrated in Fig. 8.

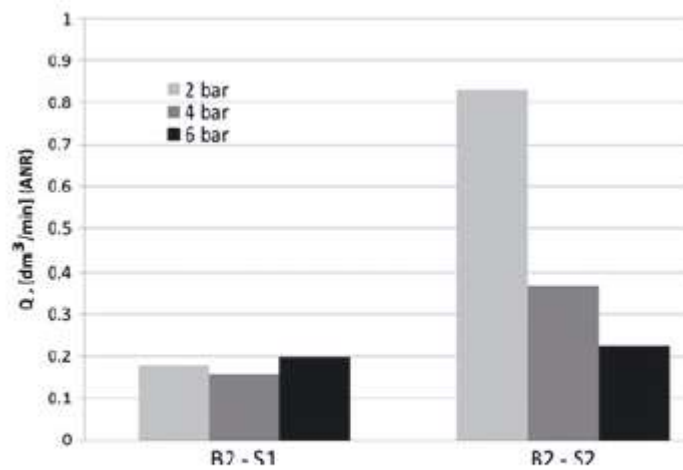

Figure 13 Leakage flow rate with seals S_1 and S_2 and thin-edged band B_2 .

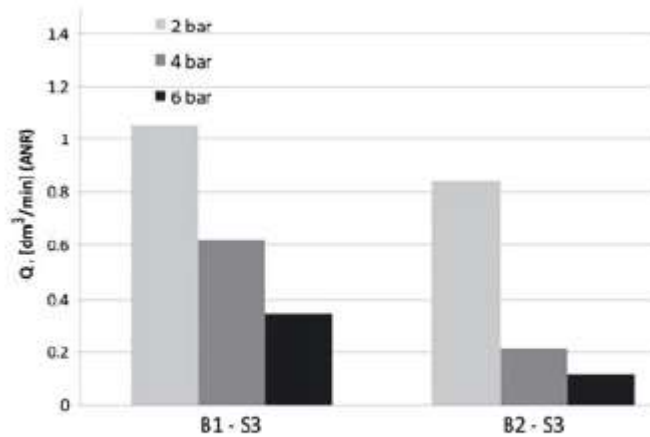

Figure 14 Leakage flow rate with seal S_3 and bands B_1 (thick) and B_2 (thin).

Results for tests using bands B_1 and B_2 with seal S_3 are shown in Figure 14. As in the previous cases, these tests confirmed the leakage reduction provided by the thin-edged band B_2 and that the leakage drops as pressure increases, the latter effect being due to the elastomer seals. As can be seen from a comparison of the results shown in Figures 13 and Figure 14 for tests with seals S_2 and S_3 and the same type B_2 band, the leakage flow rate is lower with seal S_3 than with seal S_2 . As these seals differ mainly in the configuration of

the sealing lip (both consist of NBR, and their general dimensions and cross-sectional shape are similar), the thin sharp-edged lip on seal S_3 , is decisive in limiting air leaks. This finding confirms the lesser effectiveness of a rounded lip with large radius (seal S_2) apparent from the comparison between seals S_1 and S_2 , which indicated that seal S_1 with its smaller radius lip provides better sealing performance.

A comparison between seals S_3 and S_1 tested with both the thick band B_1 and the thin band B_2 (Figures 14, 13 and 12) indicates a difference in performance with varying working pressures. In particular, seal S_1 shows lower average leakage at all working pressures than seal S_3 , indicating that seal S_1 , because of its lip configuration, closes off the leak area more precisely than seal S_3 . The influence of working pressure also differs: in the case of seal S_1 , leakage drops slightly as pressure rises, by contrast with S_3 which is much more sensitive to pressure increases. The stiffness of the seal material contributes to this behavior: the softer NBR is significantly influenced by variations in working pressure, independently of seal shape (as witnessed by the results for seals S_2 and S_3 consisting of the same material). In both cases, however, the seal is capable of compensating for the increased leakage flow rate associated with higher pressures by closing off the leak area. Seal S_3 does so more effectively, as it shows a lower leakage flow rate at 6 bar than seal S_1 .

Figure 15 shows an overall comparison of the results obtained with the 25 mm bore cylinder for each seal type and band. B_1 and B_2 refer to leakage test performed with the band alone; given that band B_2 provides a better performance than B_1 comparison considers only band B_2 with any given seal (B_2-S_1 , B_2-S_2 , ...). The assembly $B_1-S_{1,OR}$ refers to the commercial configuration. It can be pointed out that the most important parameter on leakage flow rate is the seal shape. The histogram also includes results for the tests on seal S_4 used together with band B_2 . The results with this configuration are the best obtained in the entire test campaign, confirming the earlier finding and in particular that a thin lip is better able to limit leakage. With regard to seal S_4 this is achieved thanks to an optimal combination of seal shape and material: the wide opening between the lips and the thick shape provide the structural stiffness needed to make the most of the local deformability ensured by the thin lip and NBR material. These deformability properties are essential in compensating for the discontinuity produced in the seal-band-barrel contact area and thus closing off the leak area (Figure 8). As can also be seen, the leakage values in this case are slightly higher than the limit values obtained with band B_2 alone. The final solution B_2-S_4 proposed herein reduced leakage by around 1/5 compared to the original commercial assembly $B_1-S_{1,OR}$, with major repercussions on energy consumption.

CONCLUSIONS

The paper presented a test method for rodless pneumatic actuators capable of evaluating their sealing capacity. Tests made it possible to identify

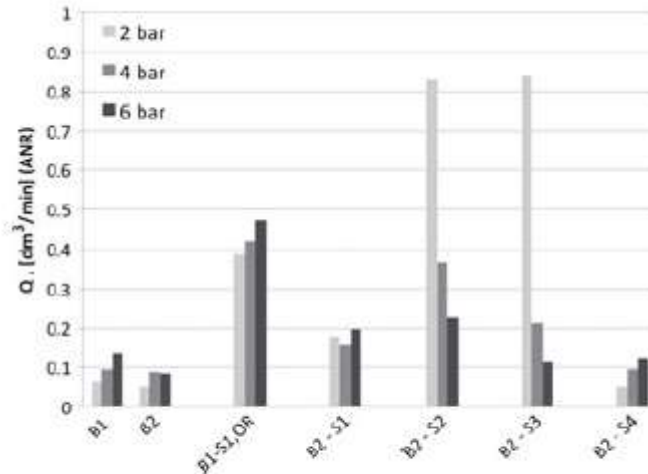

Figure 15 Leakage flow rate: comparison between the best tested solutions.

the factors that have the greatest influence on this capacity, including the geometry of the sealing band inside the barrel and the material and cross-sectional shape of the seals. Particular attention must be devoted to the construction of the band, especially as regards its edge configuration, while the type of piston seals that have the most significant effect on limiting leakage flow rate are those with sharp-edged lip. Band tension and the external load applied to the slide were not found to have an influence on leakage flow rate.

REFERENCES

1. Belforte, G., Raparelli, T., Mazza, L., Analysis of Typical Component Failure Situations for Pneumatic Cylinders Under Load. *Lubr. Eng.* 1992, 11, 840-845.
2. Belforte G., Raparelli T., Mazza L., Life Tests on Elastomeric Lip Seals for Pneumatic Cylinders. *Tribotest Journal*, 1997, 3, 251-266.
3. Manuello, A., Mazza, L., Orrù, P., Contact pressure distribution in guide bearings for pneumatic actuators. *Experimental Techniques* (accepted for publication, January 2013).
4. Prokop, H. J., Muller, H.K., Film thickness, contact pressure and friction of PTFE rod seals. In *Proceedings of the 12th International Conference on Fluid Sealing*, Brighton, UK, 1989, pp.147-163.
5. Horl, L., Haas, W., Nisler, U., A comparison of test methods for hydraulic rod seals. *Sealing Tech.*, 2009, 12, 8-13.

6. Wangenheim, M., Kozma, M., Mate, L., Gronefeld, P., Friction behaviour of grease lubricated seals. In Proceedings of the 15th International Sealing Conference, Stuttgart, Germany, 2008, pp. 265-280.
7. Belforte, G., Conte, M., Manuello Bertetto, A., Mazza, L., Visconte, C., Experimental and numerical evaluation of contact pressure in pneumatic seals. *Trib. Int.*, 2009, 42, 169-175.
8. Silvestri, M., Prati, E., Tasora, A., A theoretical study of elastohydrodynamic lubrication in elastomeric lip seals. In Proceedings of the 2nd European Conference on Tribology, Pisa, Italy, 2009, pp. 585-590.
9. Tasora, A., Prati, E., Marin, T., A method for the characterization of static elastomeric lip seal deformation. *Trib. Int.*, 2013, 60, 119-126.
10. Visconte, C., Conte, M., Mattone, M. C., Analysis of the leakage path in an air-lubricated seal. *Trib. Int.*, 2009, 6, 844-848.
11. Calvert, C., Tirovic, M. and Stolarski, T., Design and Development of an Elastomer-based Pneumatic Seal using Finite Element Analysis. *Proc. IMechE, Part J: J. Engineering Tribology*, 2002, 216(J3), 127-138.
12. Belforte, G., Manuello Bertetto, A. and Mazza, L., Optimization of the Cross-Section of an Elastomeric Seal for Pneumatic Cylinders. *J. Tribol.*, 2006, 128, 406-413.
13. Shinkarenko, A., Kligerman, Y., Etsion, I., The effect of surface texturing in soft elastohydrodynamic lubrication. *Trib. Int.*, 2009, 42, 284-292.
14. Drakunov, S., Hanchin, G.D., Su, W.C. and Ozguner, U., Nonlinear control of a rodless pneumatic servoactuator, or sliding mode versus Coulomb friction. *Automatica*, 1997, 7, pp. 1401-1408.
15. Fok, S.C., Ong, E.K., Position control and repeatability of a pneumatic rodless cylinder system for continuous positioning. *Robotics and Computer Integrated Manufacturing*, 1999, 15, 365-371.
16. Thomas, M., B., Maul, G., P., Jayawiyanto, E., A novel low-cost pneumatic position system. *Journal of Manufacturing Systems*, 2005, 4, 377-387.