

Design Of a Spar Buoy for Offshore Wind Turbines

Original

Design Of a Spar Buoy for Offshore Wind Turbines / Romano', Carlo; Giorcelli, Ermanno; Mattiazzo, Giuliana; Raffero, Mattia. - In: WIND ENGINEERING. - ISSN 0309-524X. - STAMPA. - 37:3(2013), pp. 213-217. [10.1260/0309-524X.37.3.213]

Availability:

This version is available at: 11583/2508540 since:

Publisher:

Multi Science Publishing

Published

DOI:10.1260/0309-524X.37.3.213

Terms of use:

This article is made available under terms and conditions as specified in the corresponding bibliographic description in the repository

Publisher copyright

default_article_editorial [DA NON USARE]

-

(Article begins on next page)

Design of a Spar Buoy for Offshore Wind Turbines

C. Romano¹, E. Giorcelli², G. Mattiazzo³ and M. Raffero⁴

¹*Dipartimento di Ingegneria Meccanica e Aerospaziale, 'Polito' University, Corso Einaudi 40, 10129 Torino, Italy, carlo.romano@polito.it*

²*Dipartimento di Ingegneria Meccanica e Aerospaziale, 'Polito' University, Corso Einaudi 40, 10129 Torino, Italy, ermanno.giorcelli@polito.it*

³*Dipartimento di Ingegneria Meccanica e Aerospaziale, 'Polito' University, Corso Einaudi 40, 10129 Torino, Italy, giuliana.mattiazzo@polito.it*

⁴*Dipartimento di Ingegneria Meccanica e Aerospaziale, 'Polito' University, Corso Einaudi 40, 10129 Torino, Italy, mattia.raffero@polito.it*

ABSTRACT

Offshore wind Energy demonstrated to be one of the most promising technologies for growing electric energy demand worldwide. The main objective of this research was to conceive a floating offshore structure for supporting wind turbines. The Mediterranean Sea is characterized by deep water, especially in the western area, from Italy towards Spain, and this makes floating support structures desirable, since in deep water they are cheaper than bottom fixed piles [1]. An aerodynamic, electric and mechanic model was developed and tested against experimental results of laboratory and wind tunnel tests on a small scale wind turbine, demonstrating its reliability, so it was used to determine actions on the floater and a first concept design was performed using commercial software for marine structures analysis. Further steps in this process will include integration of the turbine model with hydrodynamic calculations, as well flume, tank and open sea tests for the designed floater.

I. INTRODUCTION

Interest in renewable energy has been continuously growing during the latter years, even more after acceptance of Kyoto protocol by the most developed states, and due to an increasing sensibility of people in environmental matters. Wind energy demonstrated to be one of the most promising technologies in this field, since it's the closest to reach the so called "grid parity", that means that the cost per kilowatt produced by wind is closer and closer to the cost of the same energy produced by traditional fossil fuels. [1] The research in wind energy field has lead to continuous improvements in turbines performance, cost lowering and safety of the systems. One of the main problems of wind turbines is their size, that causes a strong visual impact, and for this reason often people unwillingly accept, or firmly oppose, wind parks where they live. One possible solution is to set wind farms in open sea, which is also a valuable solution for production efficiency, since in that environment the wind is more constant and stronger respect to land [2]. In northern Europe many offshore wind farms are working nowadays, and this confirms offshore wind power as a good technical solution for renewable energy harvesting. Up to now the offshore wind option for the Mediterranean countries has not been fully considered even though about 2000 MW offshore wind power plants have been installed in North European Countries in water depth up to 30 m on gravity and monopile foundations. The offshore wind data indicate that the

Mediterranean offshore wind energy could be in the same range of onshore wind, 165 TWh/year (5 % of 2030 forecast Mediterranean electric energy demand) of which 80 TWh/year at water depth below 30 m and 85 TWh/year at water depth from 30 up to 200 m. [3] Placing wind turbines in open sea nevertheless implies serious difficulties in design and manufacturing of wind turbines themselves, and also for supporting structures, that must be safe and lasting in a challenging environment. Waves loading and salinity are only two examples of the issues that have to be faced when designing a support structure for an offshore wind turbine. The Mediterranean Sea is characterized by deep water, especially in the western area, from Italy towards Spain [4], and this makes floating support structures desirable, since in deep water they are cheaper than bottom-fixed structures. [5]

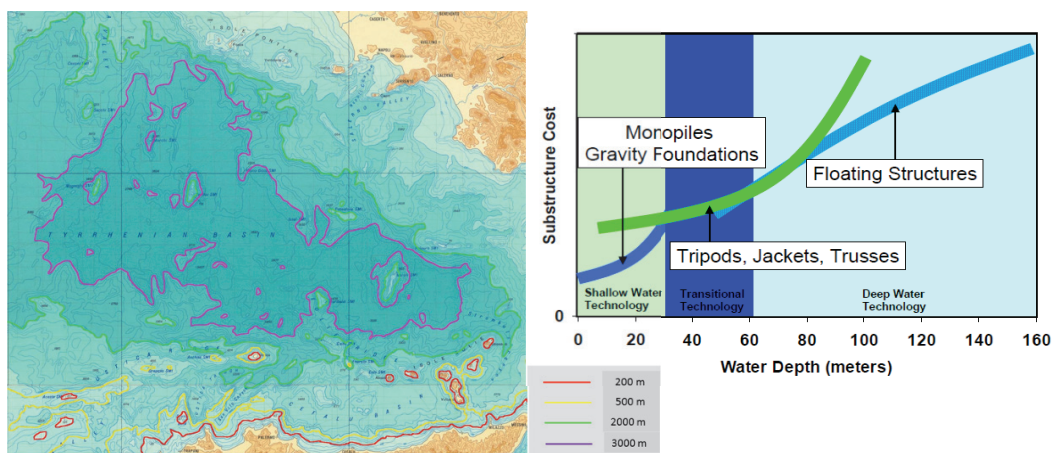

Figure 1 western Italy coast bathymetric map and cost analysis for offshore structures [5]

2. NOMENCLATURE

V	Voltage
I	current
R_s	stator resistance
L_{eq}	equivalent inductance
Z_{eq}	equivalent impedance
λ_m	magnetic flux
ω	electric frequency
R_{est}	Resistive load
E	electro motive force
ψ	permanent magnet flux
ϑ	angle between magnetic flux and real axis of electric system
φ	phase angle between current and voltage
ρ	mass density of fluid
g	gravitational acceleration
m	mass of body
D_v	displaced volume

3. METHOD OF APPROACH

The physics of a floating win turbine is complex, and involves aerodynamics, hydrodynamics, mechanics, soil mechanics, wave-structure interaction and electric power generation, just to list some. A multi physics approach is desirable to define which phenomena are coupled to other, and to give a first description of the problem. The main objective is to limit the floater’s motions, in order to let the turbine work properly: in fact even small pitching motions give the rotor a strong variation of apparent incident wind speed, especially in the case of large offshore turbines. The main problem is to determine which forces act on the floater, due to the wind turbine operation: To gather this information, an aerodynamic, electric and mechanic model was developed and tested against experimental laboratory results and wind tunnel tests on a small scale wind turbine, demonstrating its reliability, so it was used to determine actions on the floater and a first concept design was accomplished.

4. COUPLED MODEL

A coupled aerodynamic and electrical model, suitable to simulate wind power generators regardless of their dimensions, was developed, and its general layout is presented in Figure 2 . Since a small wind turbine was available for an experimental test, [6] the model was set to simulate this particular device, and a test campaign on the real device was performed to verify model predictions. Wind conditions are requested as an input, and the system gives voltage, electric current, shaft torque, axial force and rotational speed of blades as an output. This model has a multi-disciplinary basis like many other codes developed in the last years [7], [8] but was intentionally kept simple in order to have a quick and easy tool for preliminary design, that is a different purpose if compared to literature high-complexity codes [9] [10] [11]. A more complex model could be used, if necessary, in a second step of the design process, in order to achieve more detailed results and more information about the system’s behavior.

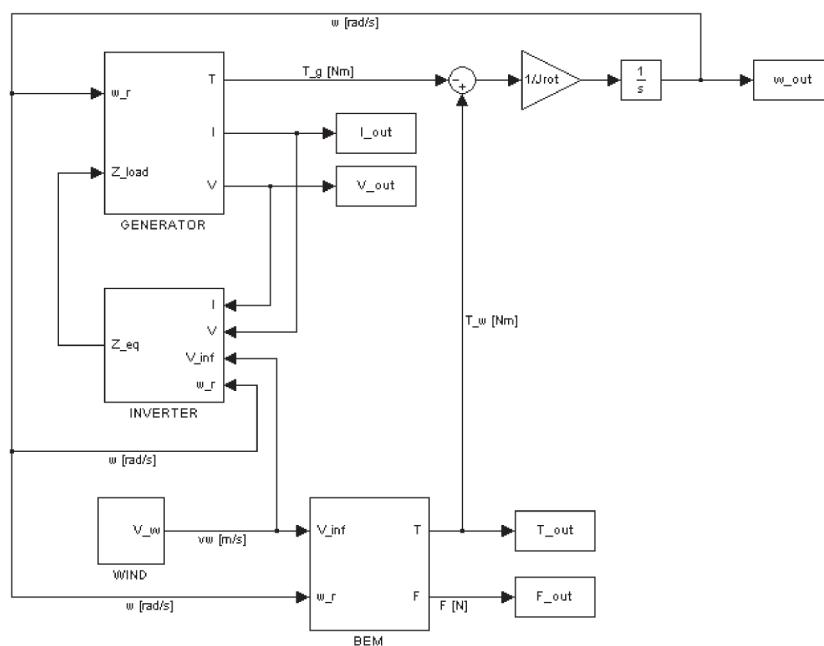

Figure 2 Model Layout

The aerodynamics module is based on classical Blade Element Momentum theory (BEM), with Glauert and Prandtl corrections, while the electrical module is based on a simple electric representation of the generator. The two modules run at the same time, exchanging data thus taking into account interactions between electric phenomena, aerodynamic and mechanical behavior. The electric part of the wind power system is made of an electric generator, a diode bridge and an inverter, that connects the generator to the grid and fits the output power to grid requirements. In order to simulate a system of this kind with high accuracy, complex and time-consuming models of components and control laws are necessary, and for a gross evaluation of system performances this does not lead to appreciable improvement in results. If we suppose a fast electric dynamics, if compared to aerodynamic and mechanical ones, we can neglect high order electric effects, thus extremely simplifying calculations.

4.1 Electric model

The electric model is intended to take into account the effects of the generator and its load in regime conditions. To avoid excessive computational resources, a simplified approach was chosen. The electric generator is modeled as an equivalent circuit [12], [13], [14]; a variable resistive load was also implemented in the model. Since the electrical system is supposed to be balanced, only one phase quantities are computed, then the output power will be three times the one computed by the algorithm. This model, coupled with the aerodynamic one, was run to forecast the turbine's behavior during regime wind tunnel tests.

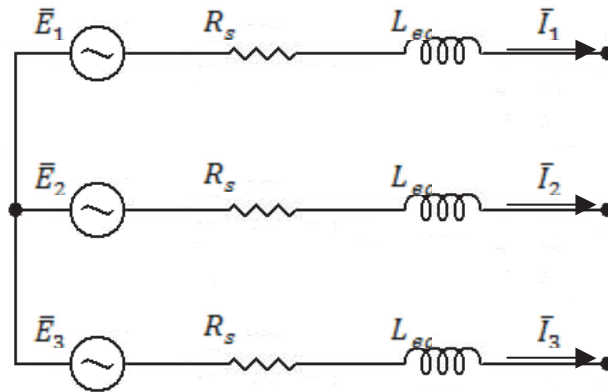

Figure 3 generator equivalent circuit

Let the system parameters be

$$\begin{cases} L_{tot} = L_{eq} + L_{load} \\ C_{tot} = C_{PFC} + C_{load} \\ R_{tot} = R_s + R_{load} \end{cases}$$

Hence the circulating current per phase in the equivalent circuit can be expressed as follows

$$\bar{I} = \frac{\bar{E}}{\bar{Z}_{tot}} = \frac{\bar{E}}{R_{tot} + i \left(\omega L_{tot} - \frac{1}{\omega C_{tot}} \right)} \quad (1)$$

Where the electro motive force (emf) is due to the permanent magnets flux ψ

$$\bar{E} = i\omega\bar{\psi} = i\omega e^{\vartheta} \quad (2)$$

With ϑ indicating the angle between magnetic flux and real axis of electrical system, calculated as integral of the angular velocity. The voltage applied on the external load can be obtained by the formula

$$\bar{V} = \bar{I} \bar{Z}_{load} \quad (3)$$

Where

$$\bar{Z}_{load} = R_{load} + i \left(\omega L_{load} - \frac{1}{\omega C_{load}} \right) \quad (4)$$

Since we suppose a pure resistive load, the terms L_{load} and C_{load} can be neglected, as the power factor correction capacity of the electric machine can be. The electric power output of the generator, in case of pure resistive load, is expressed by the formula:

$$P_e = 3VI \quad (5)$$

The mechanical input power, coming from the blades, is higher, and the difference can be ascribed mainly to friction, Joule losses and core losses.

$$P_m = 3EI \cos \varphi + C_0(\omega)\omega \quad (7)$$

The total output power dispersed above the resistive load will be considered equal to the power given by the generator. The generator parameters given by the documentation of the constructor were verified with tests in the laboratory.

4.2 Aerodynamic model

The aerodynamic model is based on the classical Blade Element Momentum theory (BEM), with Prandtl tip and hub loss factors and Buhl correction for axial induction factor [15],[16]. The Blade Element Momentum method couples the momentum theory with the local events taking place at the blades. A stream tube enclosing the rotor is discretized into annular elements of height dr , as shown in Figure 4. The lateral boundary of these elements consists of streamlines; in other words there is no flow across the elements. The different control volumes are assumed to be independent, hence each strip can be treated separately and the solution at one radius can be computed before solving for another radius. At the end of the process the weighted contribution of each section is assembled, in order to provide mechanical power produced by the turbine, thrust force and shaft torque.

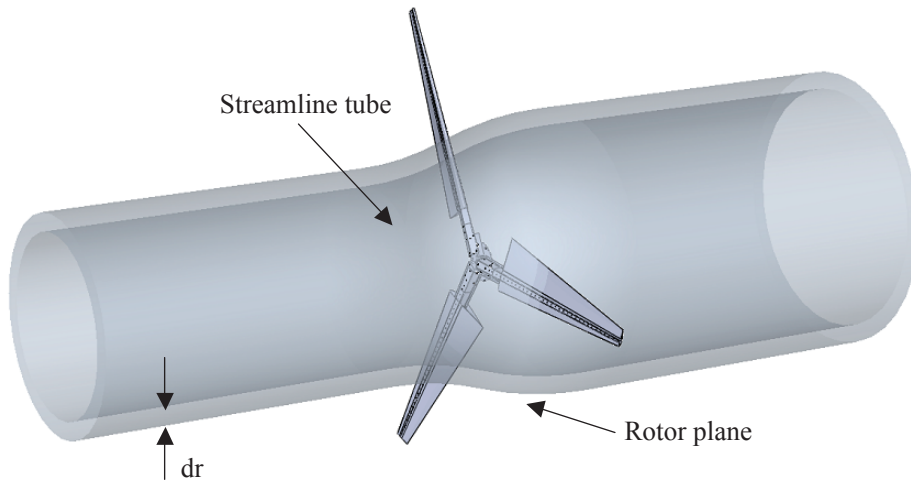

Figure 4 streamlines tube in Blade Element Momentum theory

In each blade section aerodynamic forces are due to the relative velocity between blade and air: with respect to the wing case, the wind turbine blade is rotating, thus the relative velocity is the combination of wind velocity vector, rotational velocity vector, and in case tower velocity. The wake downstream the turbine is characterized by rotation, hence the velocity triangle at the trailing edge is different from the one at the leading edge; moreover, the velocity field behind the turbine is different from the incoming velocity field. Two coefficients a , axial induction factor, and a' , tip loss factor, were defined [15], [16], to take into account the wake effect. The practical consequence is that rotational velocity and incoming wind speed are modified by these factors, thus changing local angles on the blade. This artifice permits to treat the problem like an ideal rotating wing inside a potential flow field. With these assumptions, aerodynamic lift and drag is calculated for each section of the blades. The algorithm implemented can be summarized as the flow chart in Figure 5 shows

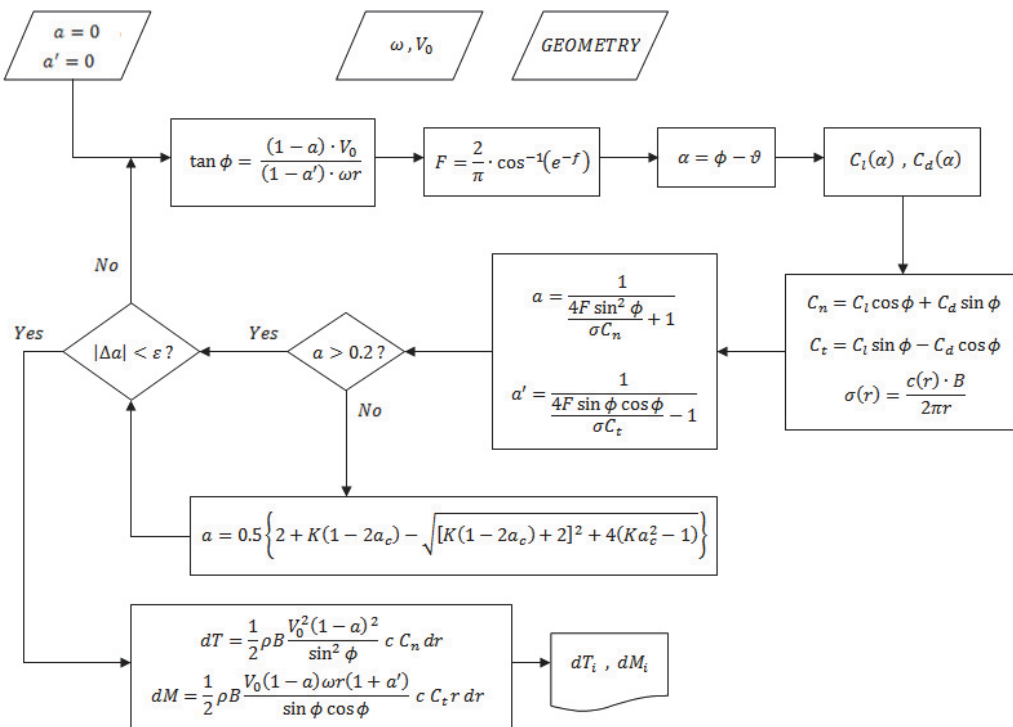

Figure 5 BEM algorithm flowchart

In the developed model, rotational speed is given by the electrical-mechanical module. The major limit of the BEM based models is that they are useful if aerodynamic coefficients of blades are well known, but for a first draft of a wind turbine, generally there is no need to design the airfoil from scratch. On the contrary these kind of models require few computational resources if compared to more complex systems, like CFD's. In the code presented here, the Prandtl and Glauert corrections are active even in post-stall conditions, since this strategy demonstrated to be more reliable in predictive calculations. [17].

5 EXPERIMENTAL TESTS

The authors had a small scale wind turbine disposable for testing [18], so the model was run with these system parameters, and some predictive calculations were performed. A test rig was built inside the laboratory and the electric generator was characterized. The test rig layout is shown in Figure 6.

The prime mover is a three phase, 4 kW electric motor, speed controlled by an inverter. A torque meter plus a phonic wheel are the instrument for mechanical parameters measurements. The generator can be loaded with a pure resistive variable load or a grid connected inverter. For early tests, and later for wind tunnel tests, it was chosen to apply a pure resistive variable load, since the main objective of the study is the mechanism to convert flow kinetic energy to electric; and not to satisfy grid requirements, the inverter behavior is not of interest in this particular case, while the regulation of the resistive load is easier. Analog control of the prime mover and data acquisition were realized a National Instruments card connected to a PC. Controls and acquisition interface are located far from the rig, in order to keep the user safe in case of malfunctioning. Figure 6 shows the realized test rig.

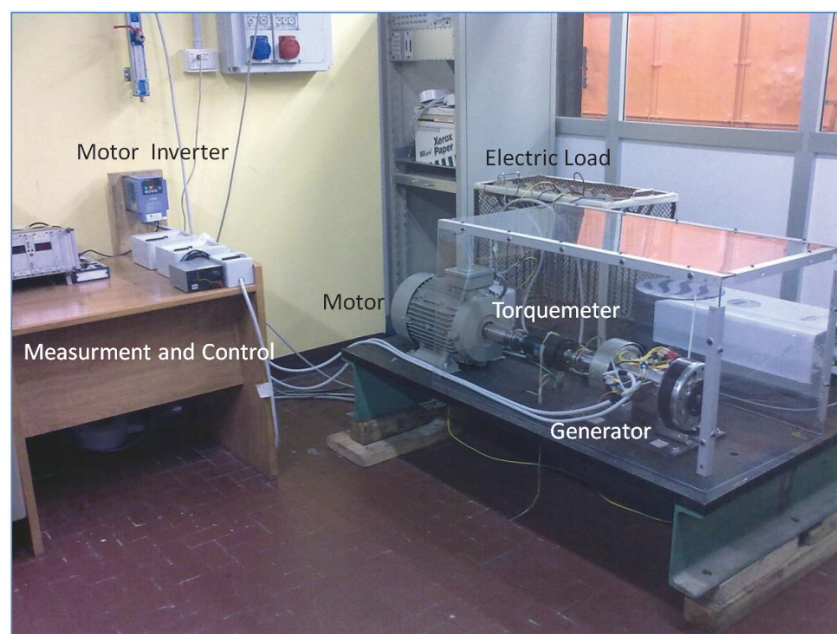

Figure 6 Test rig

Afterwards a series of experimental tests was performed in order to evaluate the model reliability. These tests were divided in two different sets: a first test of the electric part of the turbine on a test rig at Politecnico di Torino, and a series of tests in the wind tunnel of Centro Ricerche FIAT.

Figure 7 and Figure 8 summarize the laboratory test results, and show a comparison between the results of experimental and numerical characterization of the electric generator.

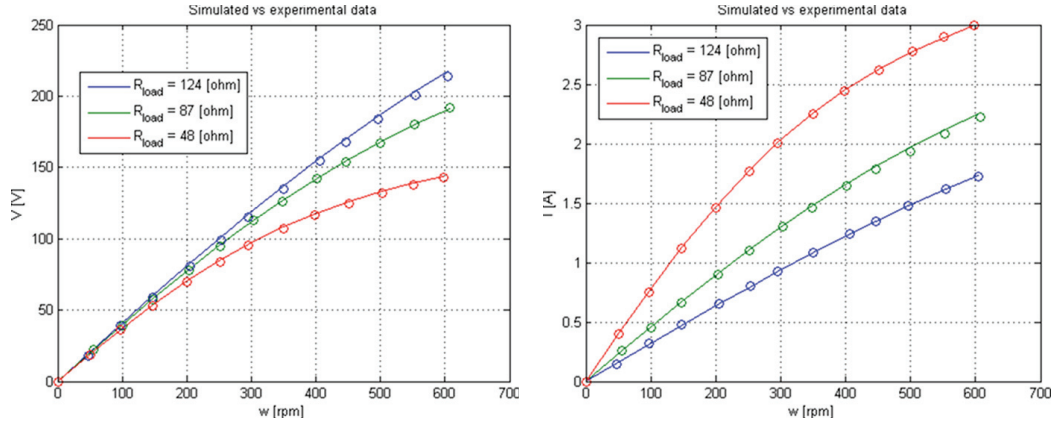

Figure 7 Voltage and current comparison, model vs experimental data

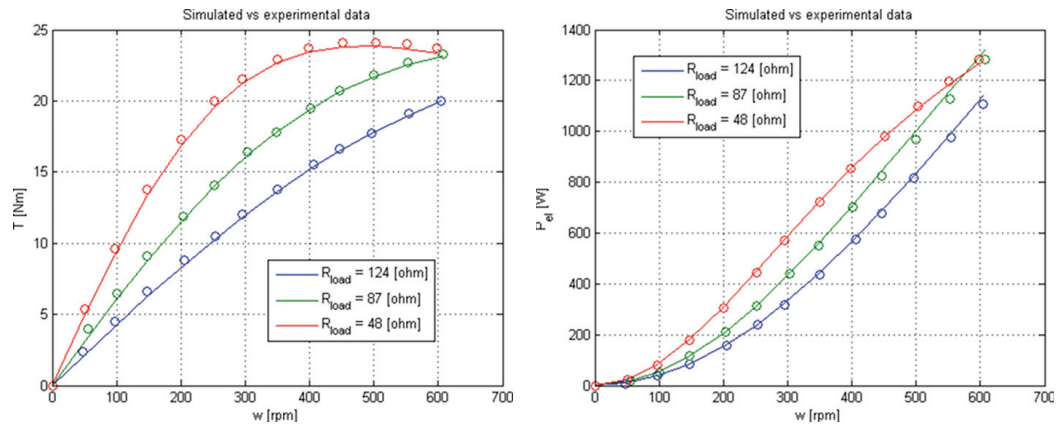

Figure 8 Torque and Power comparison, model vs experimental data

Experimental and simulation data are in very good agreement both varying angular speed of the rotor and the load resistance.

In the Wind tunnel the complete system was tested at different wind speeds; the electric load consisted in a variable array of resistors, plus a fixed resistor of about 30 Ohms, capable to dissipate the whole power generated by the wind Turbine. Electric quantities were measured with shunt resistors and a couple of load cells gave axial force and torque acting on the turbine as an output.

After the system was completely known, the forces acting on the tower completely determined, and the aero-electro-mechanical model validated, the desired inputs for the floater design were available.

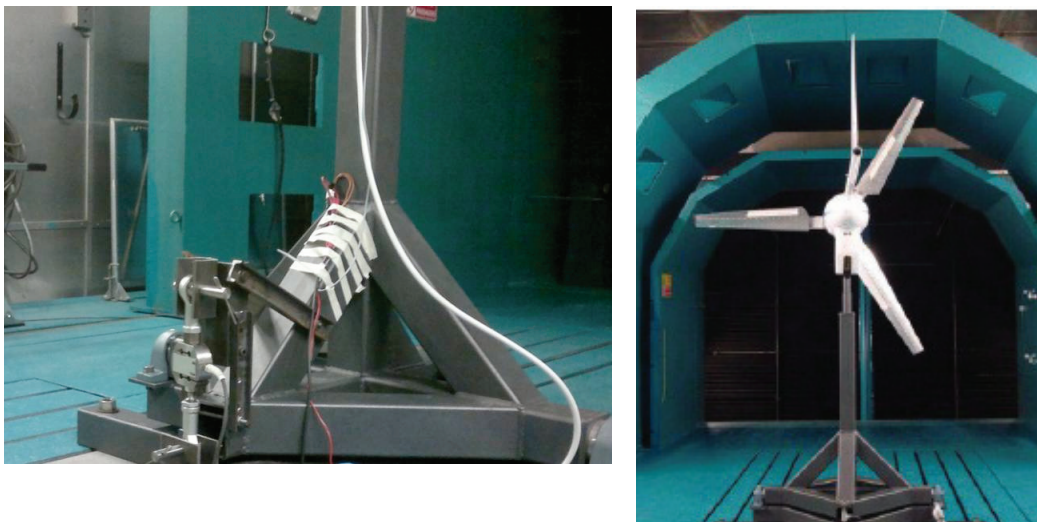

Figure 9 Wind Tunnel tests, from left to right the axial force measurement load cell and the system inside the wind tunnel

Figure 10 shows the comparison between experimental results in wind tunnel tests and the calculation outputs of the coupled model. Both thrust and torque show a good agreement with experimental data; only thrust is slightly over estimated, and this could be due to the fact that the blades aerodynamic profile, is close to a NACA 2412, but is not exactly the mentioned one; because of the construction technique. This fact leads to some differences in torque and thrust coefficients. The error in estimation is anyway acceptable, and solvable with wind tunnel airfoil characterization.

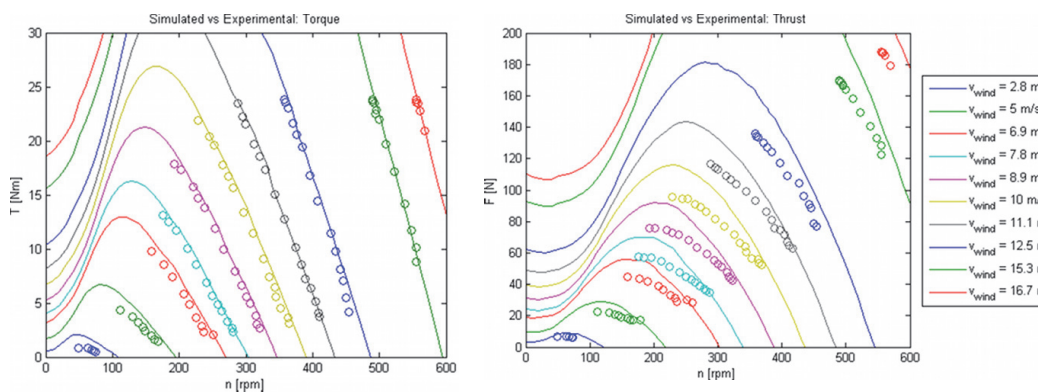

Figure 10 Experimental vs modeling results (aerodynamic-electric model)

Finally, a power curve was built, both with calculated and experimental data. The comparison is shown in Figure 11. BEM indicates mechanical power available at generator’s shaft, SIM the simulated mechanical power, including torque saturation, and EXP is the experimental curve obtained with wind tunnel tests. Adding coupling with electro-mechanical model contributes to improve experimental data fitting in simulations.

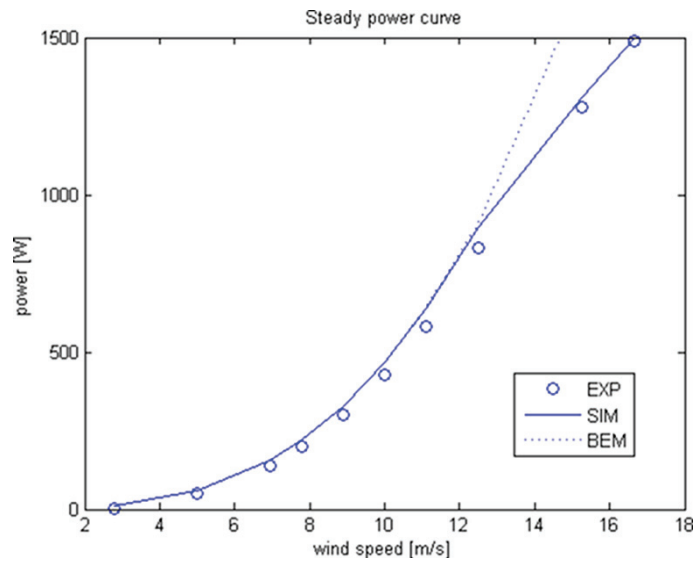

Figure 11 Steady power curve comparison, experimental and simulated

6 FLOATER DESIGN METHOD

In order to design a suitable floater for a given wind turbine, using data coming from the model that estimate forces acting on the basement, a method involving hydrostatics, hydrodynamics and coupled modeling has to be used (see Figure 12) .

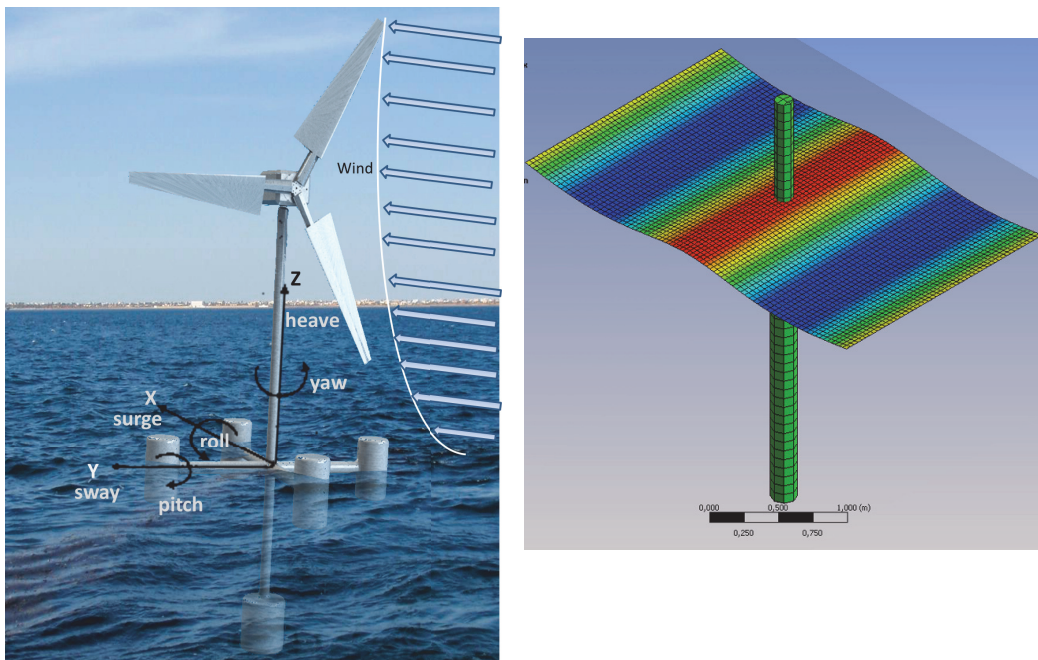

Figure 12 Problem schematics and concept solution

There are three main principles of stabilization in floaters design: buoyancy, mooring lines and ballast. [19] None of these principles can exist alone in a floater, and none of them has nowadays demonstrated superiority above the others from both economic, feasibility and reliability point

of view. The authors decided to implement the design of a spar buoy, which has its main stabilization effect in the ballast, and seems to be the most technologically reliable, despite a slightly higher cost with respect to the tension leg platform, that appears to be a highly cost-effective floater concept for wind turbines. A good proof of reliability of spar buoy concept is the Hywind project. [20] The design process is based on defining a suitable floater for a 3 kW rated power turbine. The result can be used as proof of concept and up scaled to define floaters for bigger turbines [21].

First of all, a static floating stability calculation has to be performed, in order to obtain righting moments on the floater, and then a dynamic analysis can be performed to estimate the system's behavior in waves.

For static floating stability the spar floater can be assumed as slender cylinder in water, then the main motions that should be analyzed are heave, pitch and roll (see Figure 13). Since the floater is axial symmetric, only one rotational equilibrium will be examined.

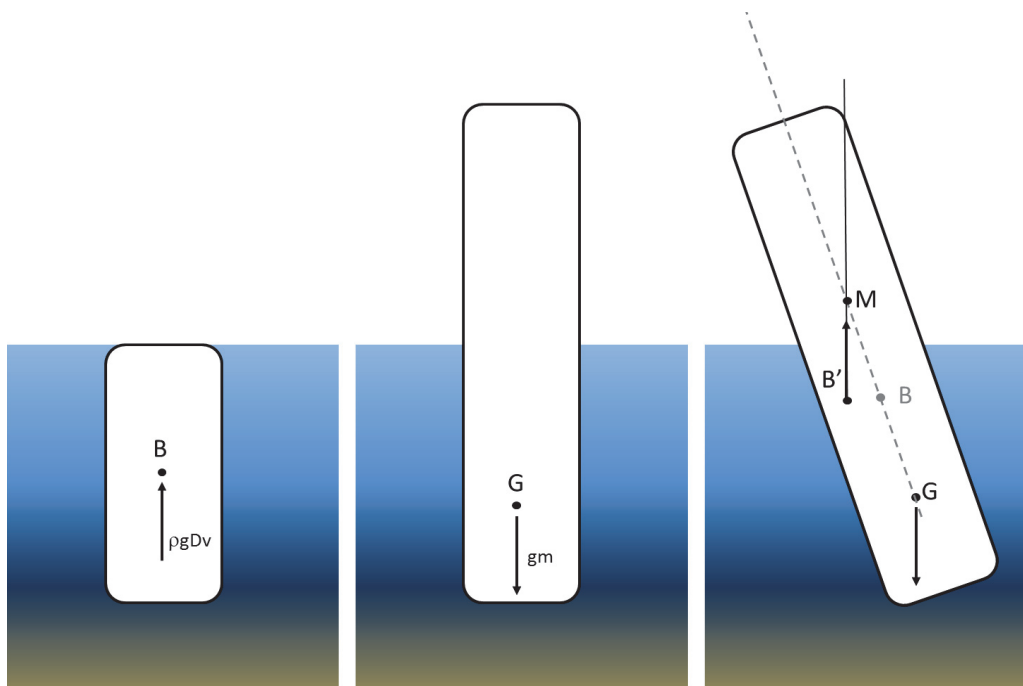

Figure 13 Static floating stability

The vertical equilibrium is granted by buoyancy force, that is the vertical up thrust that the structure experiences due to the displacement of the fluid [22] Archimedes principle states the vertical equilibrium between buoyancy and gravity forces

$$\rho g D_v = gm \quad (8)$$

Where ρ is the mass density of fluid, g is gravitational acceleration, m the total mass of body and D_v the displaced volume. Let metacenter be the point of intersection between the lines through the buoyant forces at zero heel angle and at a small heel angle. It is known from theory that to have stable equilibrium the metacenter should be above the center of mass: in this case it will

follow that the structure naturally tends to the initial position in case of disturbance of its rest conditions. A static stability curve can thus be calculated for each floater, thus identifying the maximum angle for which the structure will naturally tend to reposition in the undisturbed position in case of external forcing, like wind on the turbine. External forcing in this case is given by thrust force on the wind turbine.

From a dynamics point of view, body motions in waves in the frequency domain are of great interest, since they gave a quick idea of body response to wave input. Usually the first harmonics of motion are of interest. Frequency domain response is also useful to perform time domain simulation using the convolution technique [23], [24]. As shown in Figure 14, the linearized problem of a body moving in waves can be solved by superposition of two phenomena: free oscillation of the cylinder in still water and body restrained in waves [22].

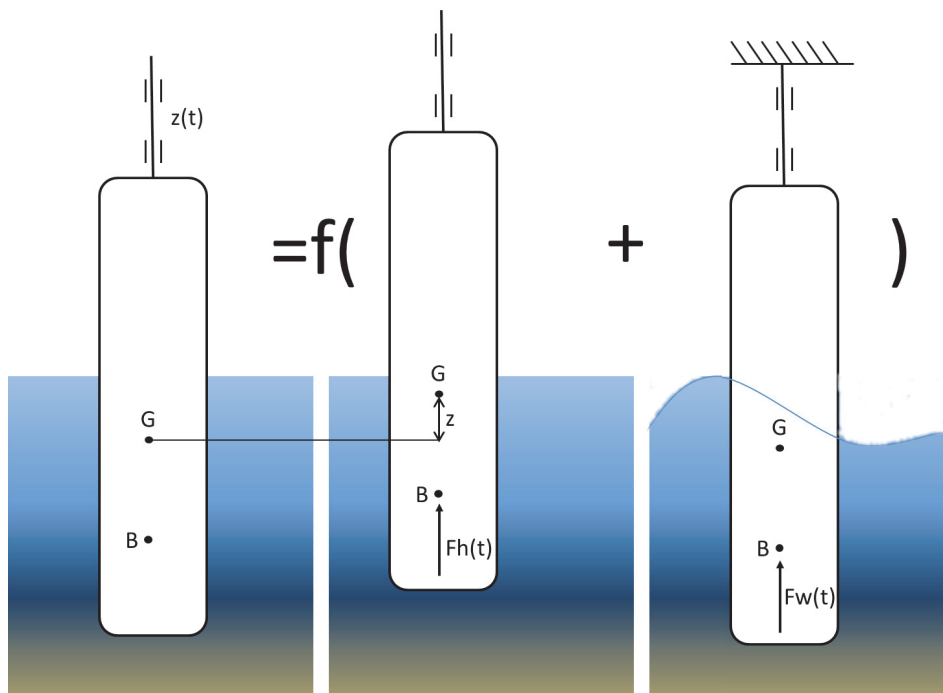

Figure 14 heaving cylinder in waves as superposition of forces due to free decay and restrained body in waves

The equation of motion will assume the form

$$(M + A)\ddot{X} + BX + KX = F_h + F_w \quad (9)$$

Where M is the mass matrix of the body, A the added mass matrix, B the damping matrix and K the equivalent stiffness matrix, that is obtained from static floating stability calculations. The term F_h represent hydro mechanical loading, induced by oscillations of the rigid body moving in still water, and F_w represent wave loading, due to the waves acting on the restrained cylinder. The amplitude response of the floater motion is called RAO, or Response Amplitude operator. Some literature good practice suggests, when starting from scratch, to use the following empirical proportions to design a floater for the wind turbine [25] [26]:

$$\left\{ \begin{array}{l} draft = \frac{3}{2} tower\ height \\ tower\ height = \frac{3}{2} rotor\ diameter \\ ballast\ mass \cong 10to20 * nacelle\ mass \end{array} \right.$$

With these assumptions, some preliminary calculations have to be performed, in order to achieve a first dimensioning of mass distribution and floater displacement:

The first dimensioning is performed in order to establish a mass distribution that allows the floater to bear the wind turbine and the tower, and to have the center of gravity in a position that grants static stability in water, then a frequency response analysis has to be performed in order to forecast a mass distribution that allows also dynamic stability. This information will drive the design of the shape of the floater. A concept design of a floater for a 3kW wind turbine (shown in Figure 12) was performed :

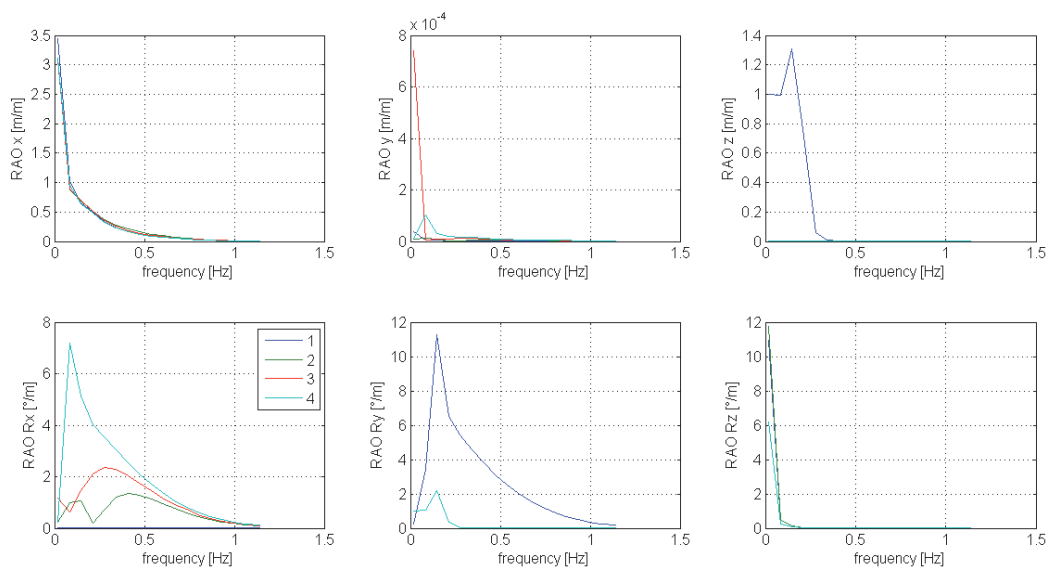

Figure 15 Dynamic response of the floater

Frequency domain calculations indicate that in most degrees of freedom the floater has a natural frequency below 0,15 Hz, the wave frequency representative of the selected reference site (Pantelleria Island, representative wave is 6,7s peak period and 1,1m significant wave height), hence different mass distribution and center of gravity positioning were compared (Figure 15).

As expected, the heave and pitch motions are the most solicited by wave loading. From these first results, it comes out that solution number 2 is the best among the analyzed cases (Figure 16). A more detailed study of this solution has hence to be done: first of all a sensitivity analysis to the whole wave spectra of reference site will be performed; consequently a series of time domain coupled simulations is needed: in this step effects of wave loading and forces coming from the tower, gyroscopic effects due to the pitching motion coupled to rotor motion and mooring lines effects have to be evaluated all together, in order to have a realistic forecast of the systems

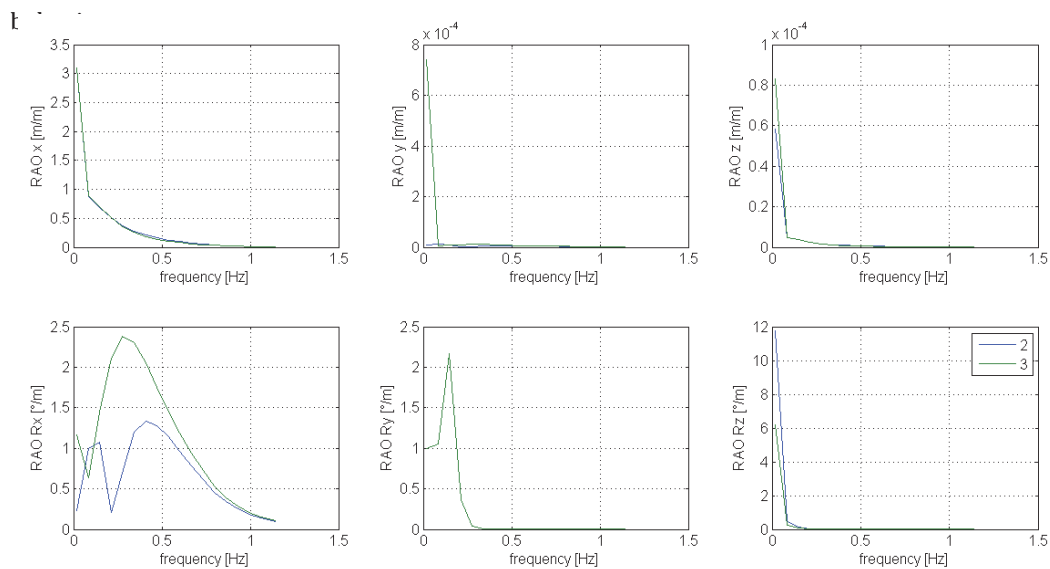

Figure 16 Most suitable floater choice

DISCUSSION AND CONCLUSIONS

An aerodynamic, electric and mechanic model was developed and tested against experimental results of laboratory and wind tunnel tests on a small scale wind turbine. Experimental activity demonstrated that the mathematical model is reliable, since results of calculation matched well with experimental data, both in laboratory and wind tunnel tests. The developed model was used to determine expected maximum actions on the floater and a first concept design was performed using commercial software for marine structures analysis.

Outputs of the design are encouraging; in fact the conceived floater is suitable for the reference site sea conditions. Further steps in this process will include integration of the turbine model with hydrodynamic calculations, as well flume, tank and open sea tests for the designed floater.

REFERENCES

1. C.Romanò et al. Experimental Methodologies for the measurement of wind turbines performance, *Proceedings of the ASME 2010 10th Biennial Conference on Engineering Systems Design and Analysis*, ESDA2010 July 12-14, 2010, Istanbul, Turkey
2. Randi A. Arinaga, Kwok Fai Cheung. Atlas of global wave energy from 10 years of reanalysis and hindcast data *Renewable Energy* 39, 49-64, 2012.
3. Gaetano Gaudiosi and Claudio Borri. Offshore wind energy in the mediterranean countries, *Revue des Energies Renouvelables SMEE'10* Bou Ismail Tipaza, 173 – 188, 2010.
4. <http://www.naturamediterraneo.com> accessed on February 2012
5. W.Musial, S. Butterfield and B. Ram Energy from Offshore wind *Offshore Technology Conference Houston texas* May 1-1 2006
6. www.deltatronic.it accessed on November 11, 2011
7. J. Jonkman et al. "Offshore Code Comparison Collaboration within IEA Wind Task 23: Phase IV Results Regarding Floating Wind Turbine Modeling", NREL, April 2010.

8. J.G. Schepers "Verification of European Wind Turbines Design Codes", EU-JOULE Project Final Report, May 2002.
9. Jason M. Jonkman, Marshall L. Buhl Jr. "Fast User's Guide", technical report, NREL , 2005
10. <http://www.gl-garradhassan.com> accessed on October 12, 2011.
11. Torben Juul Larsen, Anders Melchior Hansen "How 2 HAWC2, the user's manual", technical report, 2007.
12. Olivieri, L., Ravelli E. "Principi ed applicazioni dell'Elettrotecnica", vol II Cedam Padova ISBN: 8813191243, 1990.
13. Ferraris, L. "Macchine Elettriche", Torino, ISBN 88-7992-179-7, 2003.
14. Krause, P. C. Analysis of Electric Machinery. New York: McGraw-Hill, 1994
15. Martin O. L. Hansen "Aerodynamics of Wind Turbines", Earthscan, ISBN 978-1-84407-438-9, 2008.
16. Glauert, H. "Airplane propellers", in W. F. Durand (ed) Aerodynamic Theory, vol 4, Division L, Julius Springer, Berlin, 1935.
17. Tangler, J. , Kocurek, J. D. "Wind Turbine Post-Stall Airfoil Performance Characteristics Guidelines for Blade-Element Momentum Methods", proceedings of the the 43rd AIAA Aerospace Sciences Meeting and Exhibit Reno, Nevada January 10–13, 2005
18. Deltatronic International, "Dtwind 1.5 technical report", technical report, 2008
19. Butterfield, S.; Musial, W.; Laxson, A. Feasibility of Floating Platform Systems for Wind Turbines,. *Global Windpower 2004 Conference Proceedings* (CD-ROM), 28-31 March Chicago, Illinois. Washington, DC: American Wind Energy Association; Omni Press; NREL Report No. PO-500-36049, 2004.
20. www.statoil.com accessed on January 2012
21. R.P.L. Nijssen et al. The Application of scaling rules in up-scaling and marinisation of a wind turbine *European Wind Energy Conference and Exhibition (EWEC)*, Copenhagen, Denmark, July 2001
22. J.M.J. Journèe and W.W. Massie. Introduction in Offshore Hydromechanics *Delft University of Technology* March 2001
23. J.M. Jonkman and P.D. Sclavonious. Development of Fully Coupled Aeroelastic and Hydrodynamic Models for Offshore Wind Turbines *Proceedings of the ASME Wind Energy Symposium, Reno, Nevada* January 10-12 2006
24. J.M Jonkman and M.L. Buhl. Development and Verification of a Fully Coupled Simulator for Offshore Wind Turbines. *Proceedings of the 45th AIAA Aerospace Sciences meeting and Exhibit, Wind Energy Symposium*, January 8-11 2007
25. Sclavounos, P., Tracy, C., and Lee, S. . Floating offshore wind turbines: Responses in a seastate pareto optimal designs and economic assessment. *Department of Mechanical Engineering Massachusetts Institute of Technology*. 2007
26. Matha, D. Model development and loads analysis of an offshore wind turbine on a tension leg platform, with a comparison to other floating turbine concepts. *Technical report, NREL*. 2010

