

Non-dimensional design approach for electrodynamic bearings

Original

Non-dimensional design approach for electrodynamic bearings / Impinna, Fabrizio; GIRARDELLO DETONI, Joaquim; Amati, Nicola; Tonoli, Andrea. - STAMPA. - 13:(2012), pp. 1-15. (The 13th International Symposium on Magnetic Bearings Arlington, Virginia, USA August, 6-9, 2012).

Availability:

This version is available at: 11583/2504556 since:

Publisher:

Published

DOI:

Terms of use:

This article is made available under terms and conditions as specified in the corresponding bibliographic description in the repository

Publisher copyright

(Article begins on next page)

Non-dimensional design approach for Electrodynamic Bearings

F. Impinna*

Department of Mechanical and
Aerospace Engineering,
Politecnico di Torino
Torino, Italy

J. Detoni

Department of Mechanical and
Aerospace Engineering,
Politecnico di Torino
Torino, Italy

N. Amati

Department of Mechanical and
Aerospace Engineering,
Politecnico di Torino
Torino, Italy

A. Tonoli

Department of Mechanical and
Aerospace Engineering,
Politecnico di Torino
Torino, Italy

Abstract

Electrodynamic bearings (EDBs) are passive magnetic bearings that exploit the interaction between eddy currents developed in a rotating conductor and a static magnetic field to generate forces. Similar to other types of magnetic suspensions, EDBs provide contactless support, thus avoiding problems with lubrication, friction and wear. The most interesting aspect of EDBs is that levitation can be obtained by passive means, hence, no electronic equipment, such as power electronics or sensors, are necessary.

Despite their promising characteristics, rotors running on EDBs are still lacking a design procedure; furthermore, at present the static behavior of a bearing can only be defined by means of finite element analyses. The aim of the present paper is to present a methodology that allows performing a first approximation design without resorting to detailed FE analyses. The methodology is based on the use of non-dimensional parameters, similar to the analysis of fluid bearings (Sommerfeld number). The non-dimensional quantities are derived using dimensional analysis, and contain the main geometrical and physical parameters determining the EDBs' performance. The relation between the non-dimensional quantities characterizing the static performance of the EDB is derived using FE simulations and is presented in the form of graphs.

1 Introduction

Electrodynamically stabilized levitation for high speed rotors is now reaching the borderline between academic interest and industrial application [12, 13]. The working principle of EDBs relies on exploiting the relative motion between a nonmagnetic conductor and a constant magnetic field to generate electromagnetic forces and achieve levitation.

Prior results of research on electrodynamic bearings (EDB) for high speed rotors have pointed out their unique characteristic of producing positive stiffness by passive means [1]. Among the most interesting features of EDBs is the possibility of obtaining stable levitation using standard conductive materials at room temperature and in absence of control systems, power electronics and sensors. Relative to active magnetic bearings, their passive nature implies several advantages, for example, reduced complexity, improved reliability, and smaller size and cost [2, 3, 15, 17]. However, EDBs have also drawbacks, such as the difficulty in ensuring stable levitation in a wide speed range, requiring a proper stabilization system in order to operate safely beyond a threshold speed. Moreover, because EDBs are not provided with a control system, a very accurate design phase is needed. Differently from active magnetic bearings, the parameters of the bearing cannot be varied during operation. The characteristics of an EDB cannot be modified after the construction as they are strictly related to the geometry and the materials employed. Therefore a prediction of the dynamic behavior of rotating systems equipped with EDBs is needed to guarantee the desired performance.

Despite their promising characteristics, rotors running on EDBs are still lacking a design procedure; furthermore, at present the static behavior of a bearing can only be defined by means of finite element (FE) analyses [16]. Since the static behavior of EDBs depends on geometrical and physical parameters, the FE analyses are carried out following

*Contact Author Information: fabrizio.impinna@polito.it, C.so Duca degli Abruzzi 24, TO, CAP 10129, Italy,
Phone: +39 0110906240, Fax: +39 0110907963

a trial and error approach until the requirements are satisfied. This process is time consuming, and a long time may be necessary to carry out a simple feasibility analysis.

The present paper aims at presenting a methodology that allows performing a first approximation design without resorting to detailed FE analyses. The methodology is based on the use of non-dimensional parameters, similar to the analysis of fluid bearings (Sommerfeld number).

Initially, a reference geometrical configuration is defined and the geometrical and physical parameters influencing the EDB's properties are identified. Given the complete set of parameters, the non-dimensional quantities are associated to the dynamic model of the EDB and are derived using dimensional analysis. The relation between the non-dimensional quantities characterizing the performance of the EDB is derived using FE simulations and is presented in the form of graphs.

These graphs obtained can then be used to define the electromechanical properties and geometrical parameters of an electrodynamic bearing for a certain application. This allows simplifying the dimensioning phase since geometrical and physical parameters of the bearing can be obtained from the requirements of a given application in terms of load capacity, stiffness and geometrical constraints.

2 Axial flux EDBs

The radial electrodynamic bearing in the axial flux configuration is composed by a rotating conductor, for example, a copper disc, immersed in a constant magnetic field as shown in Figure 1.

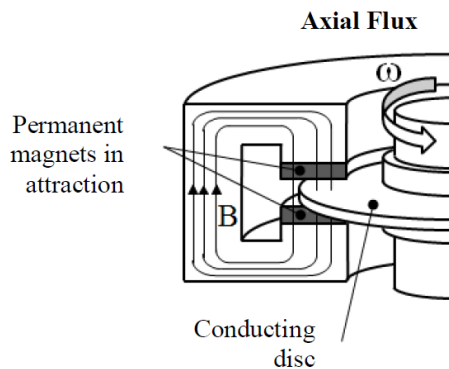

Figure 1: Radial EDB – Axial Flux Configuration.

The magnetic circuit is composed by two concentric, axially polarized, permanent magnet rings oriented in attraction and a toroidal shaped iron yoke for enclosing the magnetic flux. The conductor disc is located between the permanent magnets and is free to move radially while its motion along the axial direction is constrained. If the rotor spins around the symmetry axis of the magnetic field (centered position), an electric field takes place in the conductor, but due to the axial symmetry of the distribution, no eddy currents are induced and, consequently, no force is generated by the bearing. If the rotation occurs at an off centered position, the nonsymmetrical electric field in the conductor induces eddy currents with the consequent force generation.

In general, the performance of an EDB is strongly related to its geometry and to the physical parameters of the materials employed. To perform the analysis we consider the reference geometry shown in Figure 2. The list of all parameters taken into account is given in Table 1. It can be noticed that a relatively large number of parameters influence the EDB's properties. The extremely large number of possible configurations implies that, if the estimation of the bearing's properties is performed by FE analysis, then many analyses are necessary even during a preliminary feasibility analysis or initial dimensioning phase.

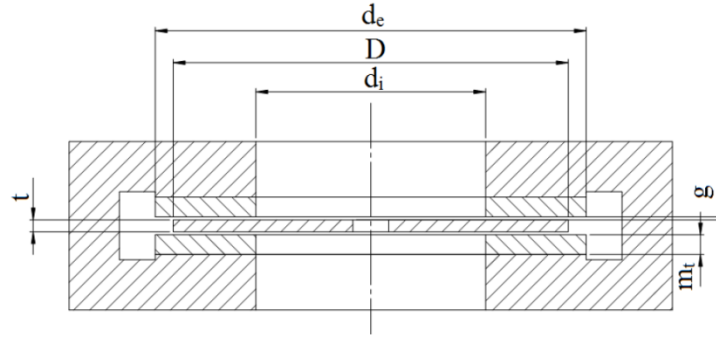

Figure 2: Axial EDBs geometric parameters

Parameter	Description
d_e	Magnetic circuit external diameter
d_i	Magnetic circuit internal diameter
m_t	Permanent magnet thickness
D	Conductor external diameter
t	Conductor thickness
g	Axial air gap
σ	Electric conductivity of the conductor
μ_o	Magnetic permeability of vacuum
B_r	Permanent magnet residual induction

Table 1: Axial Flux EDBs parameters

2.1 Modeling and design

The analytical modeling of an EDB is based on the mechanical equivalent representation of a rotating conductor in motion inside a constant magnetic field. A simplified scheme of the rotating conductor immersed in the magnetic field is presented in Figure 3a. The magnetic field is defined as going towards the reader. O and C are the geometrical centers of the magnetic field and the rotating conductor, respectively. Axes (O, x, y) are an inertial reference frame fixed to the magnetic field. Axes (O, ξ, η) constitute a rotating reference frame fixed to the conductor which rotates with angular speed Ω .

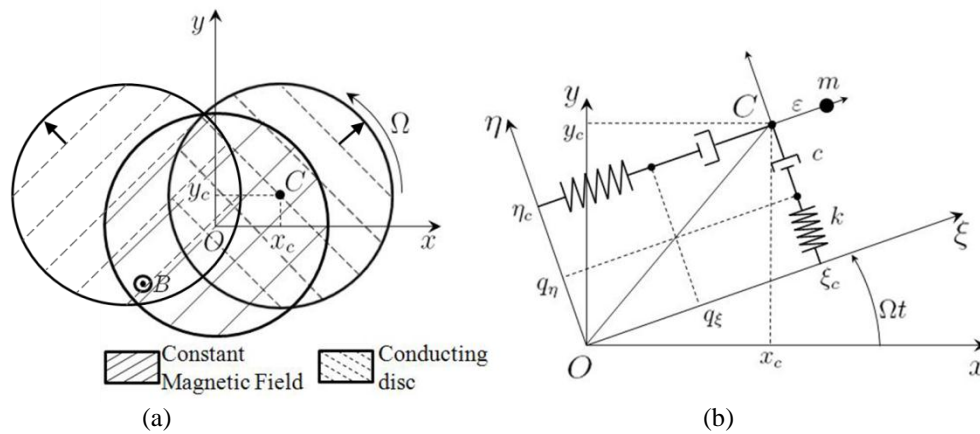

Figure 3: a) Schematic representation of a conductor rotating in a magnetic field. b) Mechanical equivalent representation of an electrodynamic bearing supporting a Jeffcott rotor.

Figure 3b shows the mechanical equivalent representation of the EDB. Considering this equivalent representation it is possible to write the state and output equations describing the dynamic behavior of the EDB. The complete derivation of the model's equations is described by the Authors in [4] and will not be developed here; instead a brief overview on the model's properties is given. The equations describing the EDB's dynamics can be written as:

$$\begin{aligned}\dot{q}_z &= (\dot{z}_c - jz_c) + (-\omega_{RL} + j\Omega)q_c \\ F_z &= kq_z.\end{aligned}\quad (1)$$

This equation is written in terms of the complex quantities where $q_z = q_x + jq_y$ represents the elongation of the spring, $z = x + jy$ is the displacement of the point C (rotation axis) relative to point O (symmetry axis of the magnetic field) and $F_z = F_x + jF_y$ is the reaction force provided by the EDB. In Eq. (1) all the quantities are defined with respect to the fixed reference frame (O, x, y). The parameter ω_{RL} is the electric pole frequency of the eddy currents inside the conductor. The developed model describes both quasi-static and dynamic behavior of an EDB. According to this model, the parameters characterizing the EDB are the mechanical equivalent stiffness k , the damping c and the electric pole frequency ω_{RL} . The electric pole frequency can be interpreted in terms of the mechanical equivalent quantities as:

$$\omega_{RL} = \frac{k}{c} = \frac{R}{L}, \quad (2)$$

where R and L are respectively the resistance and inductance of the conductor.

$$F_z = \frac{k}{1 + \left(\frac{\omega_{RL}}{\Omega}\right)^2} z_0 - j \frac{c\Omega}{1 + \left(\frac{\omega_{RL}}{\Omega}\right)^2} z_0 = F_{\parallel} + jF_{\perp}. \quad (3)$$

Where F_{\parallel} and F_{\perp} are the components of the force parallel and perpendicular to the eccentricity, respectively.

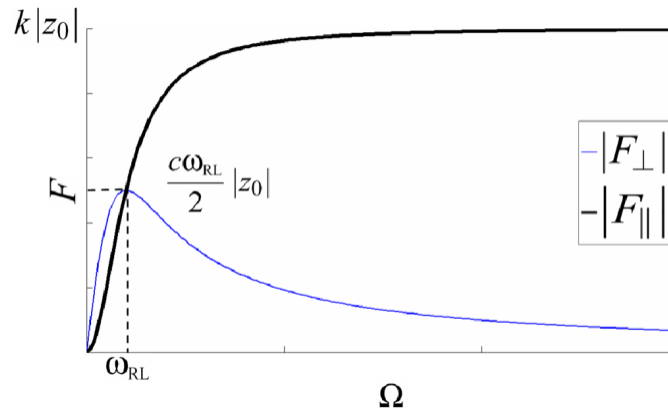

Figure 4: Forces generated by the electrodynamic bearing F_{\parallel} and F_{\perp} are respectively parallel and perpendicular to the constant eccentricity.

The plot of both forces under quasi-static conditions, presented in Figure 4, allows identifying the electric pole frequency ω_{RL} , the stiffness k and the damping c characterizing the EDB's behavior. Given the values of stiffness and electric pole frequency, the dynamics of the EDB is fully defined. Therefore these two quantities are the parameters of reference that must be defined during the design phase.

Since the characteristics of an EDB are strictly related to the properties of the materials, to the geometry and to the configuration of bearing, FE modeling represents the main tool to find out the EDB's quasi-static characteristic and

consequently to determine the values of stiffness and electric pole frequency. They can be identified performing a nonlinear curve fitting of Eq. (3) to the points obtained from the FE analysis. The result of this procedure is evidenced in Figure 5.

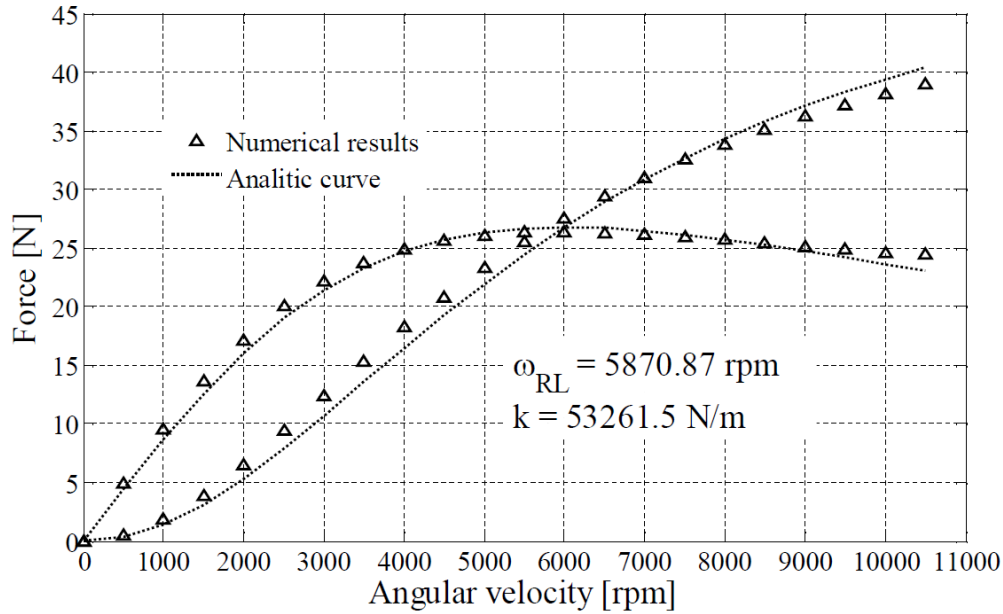

Figure 5: Curve fitting of equation with results from the numerical model [7].

3 Non-dimensional number definition

The large amount of parameters affecting the EDB's performance renders the dimensioning of this component very difficult.

Since there are many parameters affecting the EDB's performance, several FE analysis are required even during the preliminary design of the bearing in order to study the feasibility of this innovative technology to a specific application. For this reason a new approach to the problem is proposed.

This is the reason why a design methodology that allows avoiding the FE analyses at first design stage making possible to obtain immediately a first approximation value of the equivalent mechanical stiffness and electric pole frequency is needed.

The objective is to derive non-dimensional parameters that characterize the EDB, like the Sommerfeld or Ocvirk number for hydrodynamic bearings [10], and to use these parameters to predict the performance of a generic configuration. This parameter must take into account the geometry and the physical quantities involved, and must be able to describe the behavior of the system in terms of stiffness k and electric pole ω_{RL} . As for hydrodynamic bearings there are plots of non-dimensional quantities related to the four k and c coefficients as function of a non-dimensional number (Sommerfeld number or Ocvirk number), the aim of the present study is to determine a proper non-dimensional parameter and obtain diagrams of non-dimensional quantities related to the mechanical equivalent k and the electric pole frequency ω_{RL} as function of the non-dimensional number that characterizes the EDB bearing. Since at present for EDBs there are no analytical expressions that involve simultaneously geometrical and physical parameters it is necessary to identify the non-dimensional parameters that characterize the bearing (such as S or O for hydrodynamic bearings) and resort to numerical experimentation performing FEM analyses. Dimensional analysis is a powerful method that allows reducing the complexity of physical problems, in order to obtain a simpler form of the problem. The base of dimensional analysis is the Buckingham's theorem that allows reducing the number of independent variables in the problem resulting in an easier experimentation. The theorem itself only states the number of non-dimensional parameters needed to completely describe the phenomenon, but the dimensional analysis also provides a method to compute those parameters [9].

3.1 Dimensional analysis

In order to identify a correct set of physical quantities it is first necessary to define the quantities of interest in the problem (the dependent variables). The stiffness k and the electric pole frequency ω_{RL} define the behavior of the bearing [4] and therefore can be selected as the dependent variable of the analysis. The independent variables can be defined as the quantities influencing the value of k and ω_{RL} .

Considering the parameters of Table 1, it is evident, as reported in [7] that the diameter D , the thickness of the conductor t , the internal diameter of the permanent magnets d_i influence both k and ω_{RL} . Consequently all of them must be considered as independent physical quantities in this analysis. The electrical conductivity of the conductor material σ is another relevant quantity as well, because it is linked to the resistance of the conductor, that influences the eddy currents generation. The sensitivity analysis presented in [7] points out that, for what concerns the magnetic circuit the internal diameter d_i is a relevant parameter, while the external diameter d_e of the magnet does not affect the EDB's behavior provided that it is larger than the conductor D . Apart from the distribution of the magnetic flux density in the conductor, also the maximum value of the magnetic flux is essential, since the magnitude of the Lorentz force generated depends on it, therefore the thickness m_i of permanent magnets, the air gap g and the permanent magnet residual induction B_r are crucial quantities for the bearing performance.

In conclusion the physical quantities selected as characterizing parameters of the bearing (dependent variable) are: 1) the mechanical stiffness k ; 2) the electric pole frequency ω_{RL} . The independent variables are: 1) conductor diameter D ; 2) conductor thickness t ; 3) conductor electric conductivity σ ; 4) internal diameter of the permanent magnets d_i ; residual induction of the magnets B_r ; 5) permanent magnets thickness m_i ; 6) axial air gap between magnet and conductor g ; 7) magnetic permeability of vacuum μ_0 .

The procedure to compute the non-dimensional parameters is based on the definition of two generic functions respectively for k and ω_{RL} .

$$\begin{aligned} k &= \phi(D, t, \sigma, d_i, B_r, m_i, g, \mu_0) \\ \omega_{RL} &= \psi(D, t, \sigma, d_i, B_r, m_i, g, \mu_0). \end{aligned} \quad (4)$$

Since there are two quantities of interest in the problem, k and ω_{RL} , two separate studies must be performed.

The EDB system involves 9 physical quantities (dependent and independent variables) as shown by Eq. (4) and 4 units (kg, m, s, A). Therefore according to the theorem, the system can be described as a function of 5 non-dimensional parameters that must be computed by choosing a subset of 4 dimensionally independent quantities (B_r, σ, μ_0, d_i). Note that it is necessary to compute a non-dimensional parameter for each dependent variable (k and ω_{RL}). In order to perform this computation it is necessary to select from the set of physically independent variables ($D, t, \sigma, d_i, B_r, m_i, g, \mu_0$), by a trial and error process, a complete and dimensionally independent subset (B_r, σ, μ_0, d_i), and express the dimension of each of the remaining independent variables (D, t, m_i, g) and the dependent variables k and ω_{RL} as a product of powers of (B_r, σ, μ_0, d_i). The same set of independent variables can be selected for both the dependent variables k and ω_{RL} . Considering that all physical quantities have dimensions which can be expressed as products of powers of the set of reference units of measure, the condition of dimensional independence can be formalized expressing the set of independent variable as powers of the fundamental units.

$$\begin{aligned} [B_r] &= kg^1 m^0 s^{-2} A^{-1} \\ [\sigma] &= kg^{-1} m^{-3} s^3 A^2 \\ [\mu_0] &= kg^1 m^1 s^{-2} A^{-2} \\ [d_i] &= kg^0 m^1 s^0 A^0. \end{aligned} \quad (5)$$

Computing the determinant the matrix A, Eq. (6), obtained putting on each row the exponents of the measuring units of Eq. (5), it is possible to state that the linear system can be solved. Therefore the selected subset of variables is dimensionally independent and can be used to express the dimension of the remaining physical quantities.

$$A = \begin{bmatrix} 1 & 0 & -2 & 1 \\ -1 & -3 & 3 & 2 \\ 1 & 1 & -2 & -2 \\ 0 & 1 & 0 & 0 \end{bmatrix}. \quad (6)$$

Identified a set of variables (B_r , σ , μ_0 , d_i) and verified that it is complete and independent by means of equations (5) and (6), it is possible to compute the non-dimensional variables related to the remaining independent variables of the system (D , t , m_t , g):

$$\begin{aligned} \Pi_1 &= \frac{D}{d_i} \\ \Pi_2 &= \frac{t}{d_i} \\ \Pi_3 &= \frac{m_t}{d_i} \\ \Pi_4 &= \frac{g}{d_i}. \end{aligned} \quad (7)$$

The exponents of the denominator are determined imposing the non-dimensionality of the fractions. The computation of the non-dimensional parameters related to the dependent variables k and ω_{RL} described by Eq. (4) leads to:

$$\begin{aligned} \Pi_0 &= \frac{k}{\frac{B_r^2 d_i}{\mu_0}} = k^* \\ \Pi_0' &= \frac{\omega_{RL}}{\frac{1}{\sigma \mu_0 d_i^2}} = \omega_{RL}^*. \end{aligned} \quad (8)$$

As in the case of the non-dimensional number of Eq. (7), the exponents of the denominator are determined imposing the non-dimensionality of the fractions. From the Buckingham's theorem, the non-dimensional parameters Π_0 and Π_0' respectively related to the dependent variable k and ω_{RL} are expressed as function of the other non-dimensional numbers:

$$\begin{aligned} k^* &= \phi'(\Pi_1, \Pi_2, \Pi_3, \Pi_4) \\ \omega_{RL}^* &= \psi'(\Pi_1, \Pi_2, \Pi_3, \Pi_4). \end{aligned} \quad (9)$$

Buckingham's theorem and dimensional analysis can provide the number of non-dimensional parameters required to describe the behavior of a system and also a method to compute these parameters. The functions ϕ' and ψ' that governs the physical system, instead, cannot be obtained with dimensional analysis, and must be determined in another way, either from analytical models or experimentation.

3.2 Non-dimensional parameters for EDB's design

Focusing on the parameter k^* and considering Eq. (9), it is evident that if all the geometry ratios described by non-dimensional numbers of Eq. (7) are constant also k^* is constant as well. The same consideration can be done for the parameter ω_{RL}^* and therefore the functional parameters of the EDB (k and ω_{RL}) can be expressed by:

$$k = \frac{B_r^2 d_i}{\mu_0} k^*$$

$$\omega_{RL} = \frac{1_i}{\sigma \mu_0 d_i^2} \omega_{RL}^* \quad (10)$$

Since k^* and ω_{RL}^* are constant, Eq.(10) shows that the stiffness k is proportional to B_r^2 while the electric pole frequency ω_{RL} does not depend on it. This is physically reasonable and in agreement with results presented in literature [11].

Notice that, since all the geometric quantities present in the non-dimensional numbers in Eq. (7) depend on the Magnetic circuit internal diameter (d_i), it can be considered as a scale factor parameter.

Consistently with what presented in [7] Eq. (10) points out that the stiffness k is a linear function of the scale factor d_i , while the electric pole frequency ω_{RL} is inversely proportional to d_i^2 .

The reliability of the results of the dimensional analysis is checked performing different tests on a numerical model. The tests consist in performing FE analyses on a model with variable parameters to obtain the quasi-static behavior of the EDB, extracting the values of k and ω_{RL} from the quasi-static plot and computing the non-dimensional numbers k^* and ω_{RL}^* . The procedure is repeated introducing some variations in the geometrical and physical parameters of the bearing, and checking the consistency between the numerical results obtained from FE analysis and what expected from the non-dimensional representation. The geometrical and physical parameters characterizing the EDB used as reference for the tests are listed in Table 2.

Parameter	Value	Unit
d_i	64	[m]
m_t	5.5	[m]
D	100	[m]
t	3	[m]
g	1	[m]
σ	$5.998 \cdot 10^7$	[S/m]
B_r	1.4	[T]

Table 2: Geometrical and physical parameters of the EDB used for the test

Starting from the EDB whose characteristics are described in Table 2, different tests were performed changing the independent parameters one at a time. The operating conditions of the tests are summarized in Table 3.

	B_r	σ	d_i	k^*	ω_{RL}^*	k	ω_{RL}
Reference case	1.4 T	$5.998 \cdot 10^7$ S/m	64 mm	0.3426	178.95	34200	579.66
Test 1	0.7 T	$5.998 \cdot 10^7$ S/m	64 mm	0.3425	178.79	8547.2	579.11
Test 2	1.4 T	$2.999 \cdot 10^7$ S/m	64 mm	0.3426	178.95	34195	1158.0
Test 3	1.4 T	$5.998 \cdot 10^7$ S/m	128 mm	0.3431	179.00	68509	145.06
Test 4	1.4 T	$5.998 \cdot 10^7$ S/m	32 mm	0.3431	179.53	17140	2326.0

Table 3: Non-dimensional representation validation tests

The results of the tests listed in Table 3 point out that, since for all the tests the geometry ratios of Eq. (7) are constant and unchanged respect to the reference model, the non-dimensional parameters k^* and ω_{RL}^* remain constant accordingly to Eq. (9). The last two columns of Table 3 highlights that even if the non-dimensional parameter k^* and ω_{RL}^* are constant, the stiffness k and the electric pole frequency ω_{RL} have different values according to the physics of the system and consistently with Eq. (8). This demonstrates the correctness of the parameters chosen for the dimensional analysis.

The non-dimensional parameters obtained are able to describe the performance of EDBs properly, and therefore they can be used to create a non-dimensional map describing EDBs performance as an alternative to FE analyses for the preliminary design of an EDB application.

3.3 Shape factors definition

The number of independent parameters (D , t , m , g) implies to perform a 5-dimensional analysis, that would be complex and impossible to be graphically represented. A possible solution to simplify the problem consists in defining a correlation between the independent parameters in order to end up with only one parameter, as it is for hydrodynamic bearings. It seems difficult to achieve this condition, because differently from hydrodynamic bearings, there are no analytical equations describing the dependency between geometric or physical parameters and EDBs' behavior.

An alternative solution is to reduce the number of independent parameters making a set of assumptions to constrain some degrees of freedom. A proper method to reduce the complexity of the problem is to assume constant values for

the ratios $\left(\frac{D}{d_i}, \frac{t}{d_i}, \frac{m_i}{d_i}, \frac{g}{d_i}\right)$, provided that the chosen values represent meaningful values. Since only geometric

parameters are involved in the non-dimensional numbers of Eq. (7), the definition of constant values can be considered as the identification of the shape factors of the bearing. Therefore the definition of the optimal shape factor results in the simplification of the problem. The optimization of the shape factor is based on the evaluation of the stiffness k and the electric pole frequency ω_{RL} considering that the lower the ω_{RL} the easier is the stabilization of the system and the higher the stiffness the larger is the supportable load.

The non-dimensional number $\frac{D}{d_i}$ affects the performance of the bearing, since the distribution of the magnetic flux density in the conductor strongly depends on the ratio between the conductor diameter and the magnet inner diameter [7]. If $\frac{D}{d_i} \ll 1$ then there are no forces as the conductor rotates immersed in a constant magnetic flux. On

the other hand, if $\frac{D}{d_i} \gg 1$ the force is also null as the rotor spins in free space.

Considering the non-dimensional parameter $\frac{m_i}{d_i}$, the thickness of the permanent magnets affects the magnetic flux

density in the conductor: at constant air gap, thicker magnets correspond to a higher magnetic flux in the conductor and therefore an increased stiffness k , while ω_{RL} keeps constant. The trend of the magnetic flux in the conductor as function of the permanent magnets thickness has a horizontal asymptote (see Figure 6) therefore the thicker the magnets the higher the stiffness. Nevertheless the optimal value of this parameter can be identified considering that permanent magnets contribute to the weight of the bearing affecting the stability of the system [5]. Since the influence of the mass on the dynamic behavior of the EDB levitating system is not trivial, it must be the lower as possible. Therefore an optimal value of the thickness can be found on the first part of the curve of Figure 6 where the slope is maximized ($\frac{B}{B_r} \leq 0.7$).

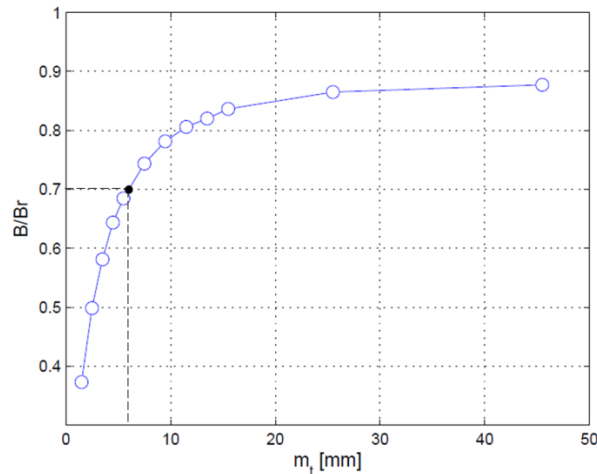

Figure 6: Percentage of magnetic flux density in the conductor as function of m_i ; $d_i = 64$ mm and $g = 1$ mm.

The non-dimensional parameter $\frac{g}{d_i}$ mainly affects the value of the magnetic flux in the conductor and consequently the stiffness k , while the ω_{RL} is not affected. According to magnetic levitation system requirements the range of interest for the air gap can be $g = 0.5 - 1.5$ mm.

For what concerns the non-dimensional parameter $\frac{t}{d_i}$ it is not possible to identify an optimal condition, as the lowest value of ω_{RL} corresponds to the lowest value of k as shown in Figure 7.

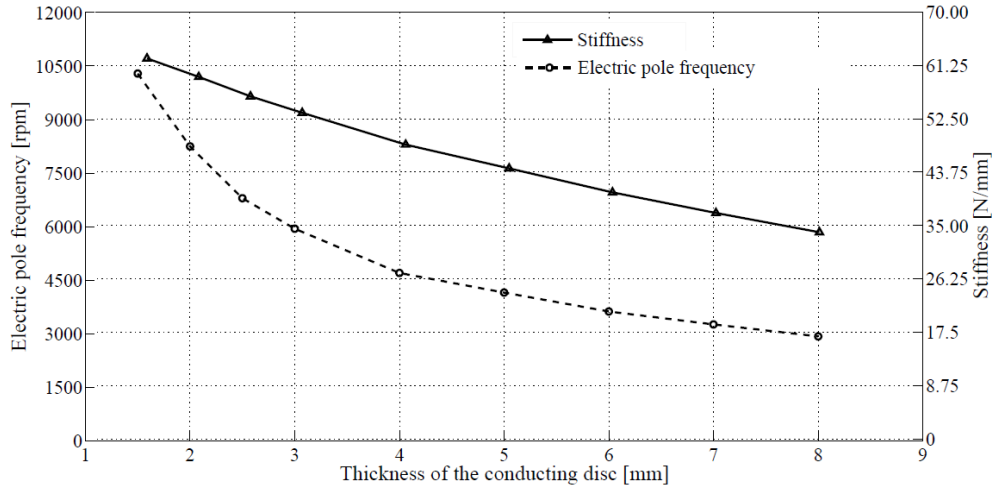

Figure 7: EDB's behavior as function of the conductor thickness t

The optimal value obtained for the shape factors are listed in Table 4.

Shape Factor	Description	Value
$\frac{D}{d_i}$	Permanent magnet outer diameter	1.72
$\frac{m_t}{d_i}$	Permanent magnet thickness	0.0859
$\frac{g}{d_i}$	Axial air gap	$\frac{1}{32}, \frac{1}{64}, \frac{1}{128}$

Table 4: Shape factors

The considerations about the EDB's shape factors allow constraining three independent variables $\left(\frac{D}{d_i}, \frac{m_t}{d_i}, \frac{g}{d_i}\right)$ resulting in a simplification of the problem. In conclusion the remaining independent variable is $\frac{t}{d_i}$ and the non-dimensional parameters of Eq. (9) become:

$$\begin{aligned}
 k^* &= \phi'(\Pi_2) = \phi'\left(\frac{t}{d_i}\right) \\
 \omega_{RL}^* &= \psi'(\Pi_2) = \psi'\left(\frac{t}{d_i}\right).
 \end{aligned} \tag{11}$$

3.4 Non-dimensional maps

The non-dimensional map describing the performance of EDBs can be determined performing tests on the numerical model. The finite element analysis allows computing the values of k and ω_{RL} for different values of $\frac{t}{d_i}$. The values of k^* and ω_{RL}^* can be computed by means of Eq. (8) considering the geometrical and physical parameters of the EDB. The non-dimensional map is the diagram describing the behavior of k^* and ω_{RL}^* as function of $\frac{t}{d_i}$.

The geometry of the bearing is the same for all the simulations performed. Only the thickness of the conductor t varies to introduce a changing in the non-dimensional parameter $\frac{t}{d_i}$. All the other non-dimensional parameters $\left(\frac{D}{d_i}, \frac{m_t}{d_i}, \frac{g}{d_i}\right)$ representing the defined shape factors are kept constant. The parameters of the EDB's model are listed in the table.

Parameter	FE Analysis 1	FE Analysis 2	FE Analysis 3
d_i [mm]	64	64	64
d_e [mm]	120	120	120
D [mm]	110	110	110
m_t [mm]	5.5	5.5	5.5
g [mm]	2	2	2
t	variable	variable	variable
$\frac{D}{d_i}$	1.72	1.72	1.72
$\frac{t}{d_i}$	variable	variable	variable
$\frac{m_t}{d_i}$	0.0859	0.0859	0.0859
$\frac{g}{d_i}$	$\frac{1}{32}$	$\frac{1}{64}$	$\frac{1}{128}$
B_r [T]	1.22	1.22	1.22
σ [S/m]	$5.998 \cdot 10^7$	$5.998 \cdot 10^7$	$5.998 \cdot 10^7$

Table 5: FE model parameters

The non-dimensional maps, obtained for three different values of the parameter $\frac{g}{d_i}$ are shown in Figure 8.

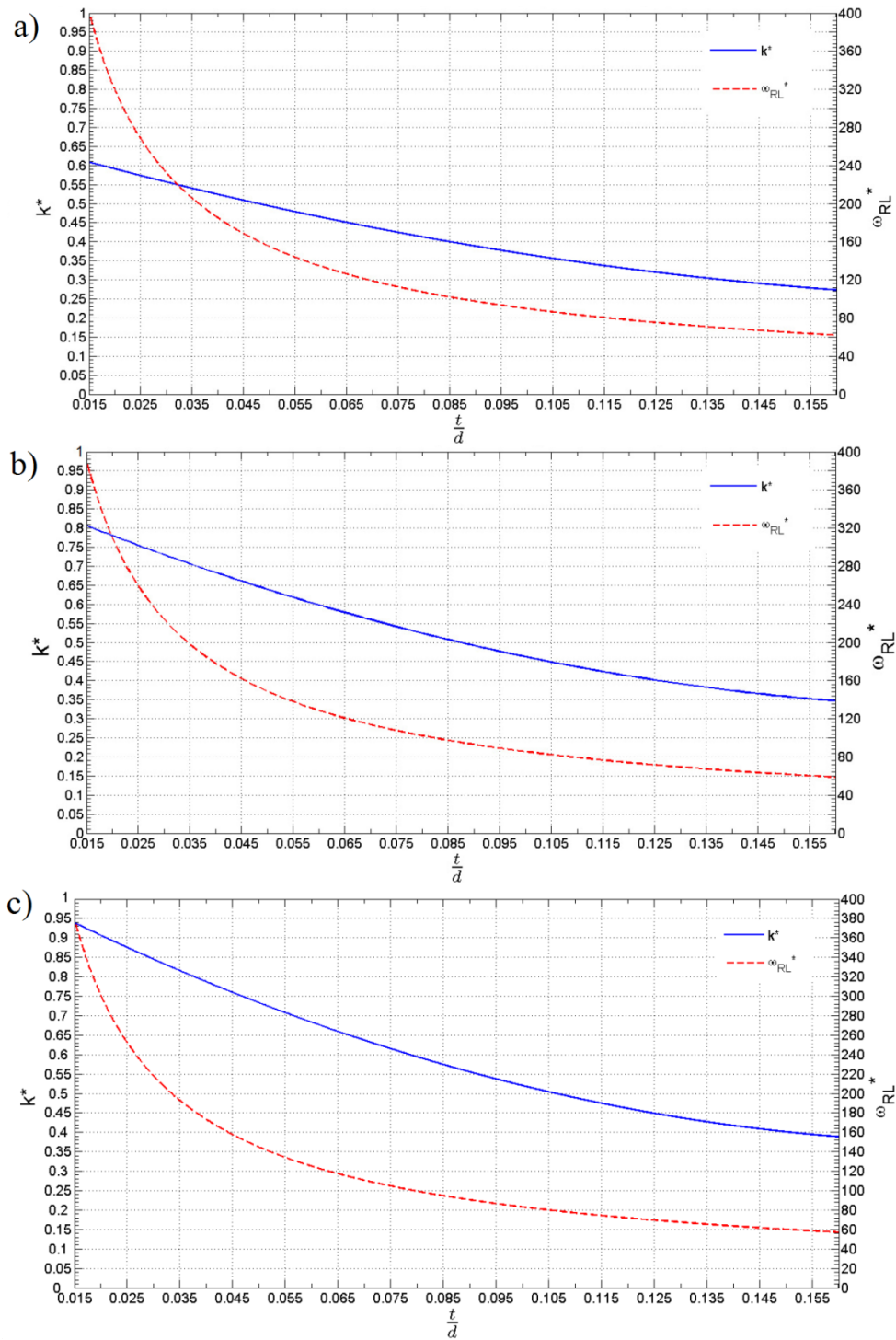

Figure 8: Non-dimensional maps considering the shape factors of Table 4 with different air gaps: a) large axial clearance $\frac{g}{d_i} = \frac{1}{32}$; b) medium axial clearance $\frac{g}{d_i} = \frac{1}{64}$; c) small axial clearance $\frac{g}{d_i} = \frac{1}{128}$.

4 Design procedure

The non-dimensional maps of Figure 8 can be used for the preliminary design of EDBs. These diagrams represent the performance of a bearing in non-dimensional form as function of a non-dimensional parameter $\frac{t}{d_i}$ and allow

the designer to determine the values of k and ω_{RL} for a given geometry (with some assumptions and constraints), avoiding to resort to finite element analyses. The maps represent the only one tool to predict the bearing behavior starting from the geometry and physical characteristics of the bearing without performing FE analysis. Therefore, defined a set of specifications, it is possible to follow a design procedure exploiting the non-dimensional maps to determine the geometry and the material of the EDB. After studying the feasibility of the EDBs employment to a specific application it is possible to perform the detailed design of the EDB starting from the geometry defined in the preliminary phase and making the optimization of the bearing's performance by means of FE analyses.

Considering the set of specifications of a specific application it is possible to use the non-dimensional maps to define the geometry of the EDB.

The suggested design procedure allows performing a feasibility analysis of the application of EDB to a certain rotating machine. An example of a preliminary design based on non-dimensional maps is described in the following steps.

- 1 Definition of the specifications of the application:
 - a. operating rotational speed: $\omega_{op} = 2000$ rad/s;
 - b. maximum radial displacement of the rotor: $z_{max} = 0.1$ mm;
 - c. mass of the rotor $m_r = 0.7$ kg;
 - d. maximum length of one EDB: $L_{EDB} = 20$ m;
 - e. shaft diameter: $D_{shaft} = 20$ m;
 - f. maximum outer diameter of EDBs: $D_{EDB} = 100$ mm.
- 2 The electric pole frequency ω_{RL} is expected to be lower than half of ω_{op} : $\omega_{RL} = \frac{\omega_{op}}{2} = 1000$ rad/s.
- 3 The bearing minimum radial stiffness k is computed as $k = \frac{0.5m_r g}{z_{max}} = 41200$ N/m.
- 4 The value of the internal diameter of the magnet d_i must be chosen according to the geometrical constraints of the application. The specification on the shaft diameter D_{shaft} introduce a direct bound on the lower value of d_i , while the maximum outer diameter D_{EDB} give a constrain on the maximum value of d_i , according to shape factor $\frac{D}{d_i}$ of Table 4. Considering the geometric constraints of the application it is possible to choose a value within the range: $20 \leq d_i \leq 53$ mm.
- 5 Considering $d_i = 0.05$ m, $B_r = 1.3$ T and applying Eq. (8) it is possible to obtain: $k_{req}^* = 0.61$.
- 6 One non-dimensional map $\left(\frac{g}{d_i} = \frac{1}{128}, \frac{1}{64}, \frac{1}{32}\right)$ must be selected. The choice must take into account the geometric constraints of the application and that the lower the axial air gap g the higher the stiffness of the bearing with equal geometry. For the present application, considering the diameter d_i and the map with $\frac{g}{d_i} = \frac{1}{128}$, the air gap is $g = 0.39$ mm.
- 7 The point P respecting the condition $k_P^* = k_{req}^*$ can be identified in the map as shown in Figure 9.
- 8 From the map it is possible to extract the value of ω_{RL}^* for the point P: $\omega_{RL}^* = 100$ (see Figure 9).
- 9 According to Eq. (8) the computation of the electric pole frequency is possible: $\omega_{RL} = 534$ rad/s.
- 10 Since the condition described at point 2 is respected, the geometric parameters of the bearing (D , t , m_t , g) can be determined according to the ratios defined by the shape factors of Table 4. For the present case the EDB respecting the requirements of the application is characterized by the values shown in Table 6.

Parameter	EDB value	Application Requirements
k	41200 N/m	>34300 N/m
ω_{RL}	534 rad/s	<1000 rad/s
d_e	93.4 mm	<100 mm
d_i	50 mm	>20 mm
D	93.4 mm	<100 mm
m_t	4.3 mm	-
t	3.8 mm	-
g	0.4 mm	-
L_{EDB}	13.2 mm	<20 mm
σ	1.22 T	-
B_r	$5.998 \cdot 10^7$ S/m	-

Table 6: EDB's parameter obtained following the design procedure for the application example.

If the condition described at point 2 was not respected an iterative process from point 4 using a larger d_i is needed. The same iteration must be done even if the condition is satisfied but an optimization process is requested. In this case the diameter d_i can also be reduced.

If after the iterative process considering the largest d_i defined at point 4 the condition described at point 2 is not respected, then it can be concluded that axial flux EDBs are not suitable for that specific application.

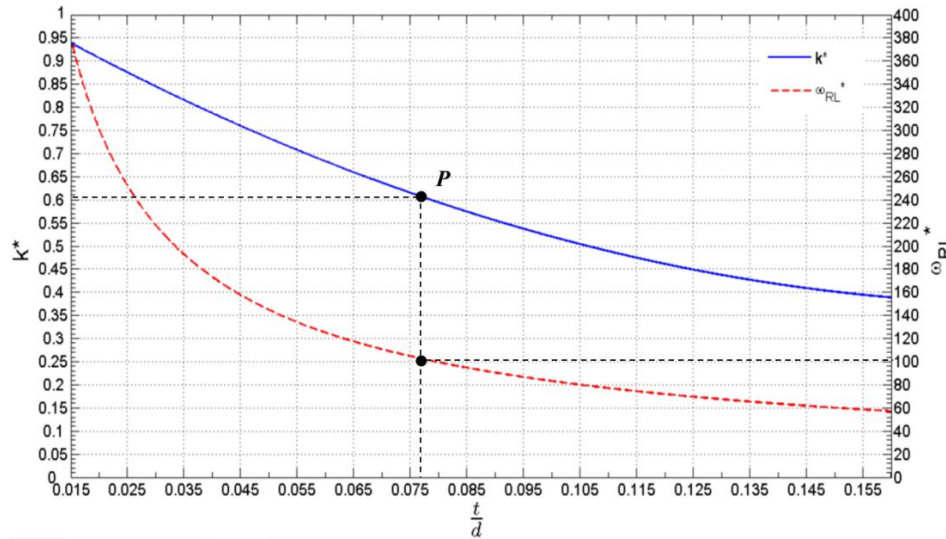

Figure 9: Non-dimensional map used for the example application.

The design flow presented allows making a preliminary design of an electrodynamic bearing able to satisfy the application requirements in terms of working frequency range and radial stiffness reading the non-dimensional maps without resorting to FE analysis. Once the feasibility analysis gives a positive result, FE modeling tool will be used for the detailed design of the system.

6 Conclusions

Electrodynamic bearings are an attractive alternative to active magnetic bearing for high speed industrial application but they are still lacking a clear design procedure to be followed. Furthermore, so far the EDB's behavior could only be defined by means of finite element analyses applying a trial and error approach resulting in a time consuming procedure not compatible with industrial needs.

Non-dimensional maps allowing the definition of the EDB's performance for a given application have been presented in the present paper. The dimensional analysis was used to compute non-dimensional parameters describing the behavior of EDBs properly. Non-dimensional maps describing the bearing's behavior have been defined performing a set of FE analysis. The non-dimensional maps can be considered as a design tool for the preliminary design of EDBs levitating systems. An important contribution of the present work is the reduction of the time needed to decide geometrical and physical parameters of the bearing starting from the requirements of a given application such as load capacity, stiffness and geometrical constraints. The FE analysis can be avoided during the preliminary design, but are still necessary for the detailed design of the system.

The non-dimensional representation obtained can be a support in understanding how each parameter of the bearing affect the final performance of the device. The insight provided by the non-dimensional description on the influence of the scaling, the residual induction of the permanent magnets and the electric conductivity of the conducting disc clarifies which direction can be followed for future improvements.

References

- [1] P. A. Basore. Passive stabilization of flywheel magnetic bearings. Master's Thesis, Massachusetts Institute of Technology, Cambridge, USA, 1980.
- [2] R. F. Post and D. D. Ryutov. The inductrack: a simpler approach to magnetic levitation. *IEEE Transactions on Applied Superconductivity*, 10 (1) 901-904, 2000.
- [3] R. D. Thornton and M. T. Thompson. Magnetically based ride quality control for an electrodynamic maglev suspension. *Proceedings of the 4th International Symposium on Magnetic Suspension Technology*, Gifu city, Japan, pp 303-311, October 1997.
- [4] N. Amati, X. De Lépine and A. Tonoli. Modeling of electrodynamic Bearings. *ASME Journal of Vibration and Acoustics*, 130, 2008.
- [5] A. Tonoli, N. Amati, F. Impinna and J. G. Detoni. A solution for the Stabilization of Electrodynamic Bearings: Modeling and Experimental Validation. *ASME Journal of Vibration and Acoustics*, 133, 2011.
- [6] D. Rodger, H. C. Lai and P. J. Leonard. A Comparison of Finite-Element Models for 3-D Rotating Conductors. *IEEE Transactions on Magnetics*, 38(2), 2002.
- [7] N. Amati, A. Tonoli, E. Zenerino, J. Detoni, J. F. Impinna. Design methodology of electrodynamic bearings. *AIAS - Associazione Italiana per l'Analisi delle Sollecitazioni XXXVIII Convegno Nazionale*, 9-11, Politecnico di Torino, 2009.
- [8] G. Genta, X. De Lepine, F. Impinna, J. Girardello, N. Amati, A. Tonoli. Sensitivity analysis of the design parameters of electrodynamic bearings. *Proceedings of IUTAM Symposium on Emerging Trends in Rotor Dynamics*, New Delhi, India 23-26 March 2009, pp.1-10.
- [9] Robert W. Fox, Alan T. McDonald, Philip J. Pritchard. *Introduction to Fluid Mechanics*. John Wiley & Sons, New Jersey, 2003.
- [10] G. Genta. *Dynamics of Rotating Systems*. Springer, New York, 2006.
- [11] A. Canova and B. Vusini. Design of Axial Eddy-Current Couplers. *IEEE Transaction on Industry Applications*, 39 (3) 725-733, 2003.
- [12] A. Filatov and, E. H. Maslen. Passive Magnetic Bearing for Flywheel Energy Storage Systems. *IEEE Trans. Magn.*, 37, pp. 3913-3924, 2001.
- [13] A. Filatov. Flywheel energy storage system with homopolar electrodynamic magnetic bearing. *Proceedings of the tenth international symposium on magnetic bearings*, Martigny, Switzerland, 2006.
- [14] J. Sandtner and, H. Bleuler. Electrodynamic Passive Magnetic Bearing With Planar Halbach Arrays. *Proceedings of the Ninth International Symposium on Magnetic Bearings*, Lexington, KY, Aug. 3-6, 2004.
- [15] R. F. Post and D. D. Ryutov. Ambient-Temperature Passive Magnetic Bearings: Theory and Design Equations. *Proceedings of the Sixth International Symposium on Magnetic Bearings*, Massachusetts Institute of Technology, Cambridge, MA, Aug. 5--7, pp. 109—122, 1998.
- [16] T. A. Lembke. 3D-FEM Analysis of a Low Loss Homopolar Induction Bearing. *Proceedings of the Ninth International Symposium on Magnetic Bearings*, Lexington, KY, Aug. 3-6, 2004.
- [17] D. A. Bender and R. F. Post. Ambient-Temperature Passive Magnetic Bearings for Flywheel Energy Storage Systems. *Proceedings of the Seventh International Symposium on Magnetic Bearings*, ETH Zurich, Switzerland, pp. 153-158, Aug. 23-25, 2000.