

Evaluation of sorption and storage characteristics of oxidation catalysts with dynamic experiments

Original

Evaluation of sorption and storage characteristics of oxidation catalysts with dynamic experiments / Barresi, Antonello; Cittadini, Marco; Baldi, Giancarlo. - STAMPA. - 1:(1997), pp. 421-424. (Intervento presentato al convegno First European Congress on Chemical Engineering, ECCE1 tenutosi a Firenze (Italy) nel 4-7 May 1997, in occasion of ICHeaP-3, the Third Italian Conference on Chemical and Process Engineering).

Availability:

This version is available at: 11583/2501980 since: 2017-09-19T15:07:00Z

Publisher:

AIDIC

Published

DOI:

Terms of use:

This article is made available under terms and conditions as specified in the corresponding bibliographic description in the repository

Publisher copyright

(Article begins on next page)

A.A. Barresi, M. Cittadini and G. Baldi

421-424

The First European Congress on Chemical Engineering

in occasion of **ICheaP-3**
The third Italian Conference
on Chemical and Process Engineering



Florence, Italy May 4-7, 1997



Promoted by EFCE:
The European Federation of Chemical Engineering
Event Number 601

Organised by: AIDIC:
The Italian Association of Chemical Engineering

Proceedings
Vol. 1

The First European Congress on Chemical Engineering is promoted by the
European Federation of Chemical Engineering (EFCE).

It is organized by the Italian Association of Chemical Engineering (**AIDIC**) with the participation
of the Italian Chemical Society (SCI).

The Congress is sponsored by:

Snamprogetti



Tecnimont



Amersham



European Community (DGXII-B2)



CIIC Politecnico di Milano



Volume 1 Content

CHEMICAL REACTION ENGINEERING
POLYMER REACTION ENGINEERING
NEW CATALYTIC ROUTES AND TECHNOLOGIES FOR THE PRODUCTION OF SYNTHESIS GAS
INNOVATIVE CHEMICAL ENGINEERING DEVELOPMENTS IN ENVIRONMENTAL CATALYSIS
AIR POLLUTION CONTROL
SOIL BIOREMEDIATION & TREATMENT OF INDUSTRIAL WASTES
A SYSTEM ENGINEERING APPROACH FOR ENVIRONMENTAL BENEFIT
SAFETY

Volume 2 Content

COMMINUTION AND CLASSIFICATION
MIXING AND PREVENTING DE-MIXING OF PARTICULATE SOLIDS
PARTICLE CHARACTERIZATION
DRYING
MEMBRANE TECHNOLOGY
DISTILLATION / SEPARATION
HIGH PRESSURE TECHNOLOGY
CRYSTALLIZATION
THERMODYNAMICS AND INTERFACIAL PHENOMENA

Volume 3 Content

FLUID MECHANICS
COMPUTER AIDED PROCESS ENGINEERING
PRODUCTION DESIGN AND PROPERTIES OF MATERIALS
PROCESS ENGINEERING AND INDUSTRIES

Volume 4 Content

EDUCATION
YOUNG RESEARCHERS FORUM
BIOTECHNOLOGY
FOOD
CLEANER PRODUCTION
ADSORPTION
ELECTROCHEMICAL
FRACTALS
KINETICS
EXTRACTION
ENERGY SAVING
Author Index

In order to make this volume available as economically and as rapidly as possible, the typescript has been reproduced in its original form. This method unfortunately has its typographical limitations but it is hoped that they in no way distract the reader.

AIDICservizi S.r.l. Milano Italy

International Honorary Committee

H. Hofmann (EFCE President, Germany)
R. Alessandrello (AIDIC President, Italy)
M. Ghezzi (Congress President, Italy)
J. Aittamaa (Finland)
G. Astarita (Italy)
E.J. Bavister (Great Britain)
W. Berger (Switzerland)
D. Bricknell (CEFIC)
O. Erga (Norway)
A. Fredenslund (Denmark) †
P. Glavic' (Slovenia)
A.M. Kutepov (Russia)
Z. Leszczynski (Poland)
G. Marton (Hungary)
J. Malagelada (Spain)
R. Mormont (Belgium)
J. Novosad (Czech Rep.)
P.A. Pilavachi (EC)
P. Trambouze (France)
D. Tsahalis (Greece)
R.M. Voncken (The Netherlands)
A. Zaussinger (Austria)

Organizing Committee

Chairman G. Poli (AIDIC)
Vice Chairman G. Bozzano (Italy)

Congress Secretariat

AIDIC Secretariat c/o AMBRA POLI
Via Ludovico Muratori, 29
20135 Milano, Italy

Phone +39-2-55191025
Fax +39-2-55190952
e-mail: aidic@ipmch8.chin.polimi.it

International Scientific Committee

Co-Chairmen S. Pierucci (I)
J. Villermaux (F) †
P. Andreussi (I)
G. Baldi (I)
P. Berbenni (I)
G. Biardi (I)
L. Bogle (UK)
A. Brambilla (I)
S. Carrà (I)
P. Centola (I)
A. Chianese (I)
W.J. Coumans (NL)
S.R. de Silva (N)
B. Delmon (B)
M. Dente (I)
S. Di Cave (I)
G. Donati (I)
V. Dovì (I)
E. Drioli (I)
G. Eigenberger (D)
B. Fabiano (I)
I. Farkas (H)
E. Forssberg (S)
P. Forzatti (I)
T. Hahn (D)
I. Kikic (I)
T. Koloini (SLO)
K. Leschonski (D)
F. Magelli (I)
F. Marechal (B)
G.B. Marin (NL)
G. Marrucci (I)
B. McKenna (UK)
M. Moresi (I)
G. Nencetti (I)
H.J. Pasman (NL)
I. Pasquon (I)
A. Pavan (I)
F. Pla (F)
K. Porter (UK)
J.L. Py (F)
M. Rovaglio (I)
S. Sicardi (I)
V. Specchia (I)
J. Tracez (F)
F. Trifirò (I)
G. Vetter (D)
M. Weijnen (NL)
S. Zanelli (I)
B. Zanoni (I)

EVALUATION OF SORPTION AND STORAGE CHARACTERISTICS OF OXIDATION CATALYSTS WITH DYNAMIC EXPERIMENTS

Antonello A. Barresi, Marco Cittadini and G. Baldi

Dip. Scienza dei Materiali e Ingegneria Chimica, Politecnico di Torino
Corso Duca degli Abruzzi 24, 10129 Torino, Italy; e-mail: barresi@polchi1.polito.it

Abstract - The use of dynamic experiments is useful not only for the investigation of the intrinsic kinetics, but also for the evaluation of the sorption characteristics of the catalysts, and for their quick evaluation and comparison, especially for nonsteady-state applications. In this work the method will be applied to a catalyst for complete oxidation of VOCs, using a step change in the feed concentration of combustible and oxygen.

Introduction

The catalytic oxidation of organic compounds is nowadays a very important technology for the control of industrial emissions: in comparison with the thermal oxidation, it offers lower operating costs and a smaller environmental impact. For the treatment of very lean emissions, the employment of forced nonstationary burners with regenerative heat recovery sections is very promising, because by this way it is possible to treat autothermally also waste gases for which the adiabatic temperature rise is only 10-30 K (Eigenberger and Nieken, 1994; Matros, 1985; Matros and Bunimovich, 1996).

For the design and optimisation of this type of devices (burners with periodical flow reversal, network of burners with variable feed position) in some cases may be important to know the kinetic expression in nonstationary condition; certainly it is always necessary to evaluate the sorption characteristics of the catalyst, both for a screening or a comparison of the catalysts that have to be employed and for an optimisation of the operative conditions.

Another application where it is important to evaluate quickly and simply the sorption characteristics of the catalyst is the treatment of the automotive exhausts: in fact, in this case the composition of the gases that have to be treated changes with an high frequency.

A technique based on the continuous monitoring of the response of the catalytic burner to a step change in the concentration either of the organic pollutants or of the oxygen has been recently set up at Politecnico di Torino, and has been applied to the complete oxidation of VOCs over commercial catalysts.

In recent years a similar technique has been employed to investigate the intrinsic kinetics of deep oxidation reactions, and has been shown to be able to evidence cases of self-inhibition and changes in the apparent kinetic law (Barresi *et al.*, 1995; 1996).

In this work the complete oxidation of different aromatic compounds will be considered as an example of application, measuring the sorption capacity of a platinum based catalyst for oxygen and organic compounds in different conditions of concentration and temperature. It will be shown that by this way it is possible to obtain also some information on the nature of the adsorbed layer (reversible or irreversible adsorption).

Experimental apparatus

The bench scale reactor is shown in Figure 1. The inlet gas can be air, nitrogen or a synthetic mixture of nitrogen and oxygen: it is also possible to switch from one gas to the other by means of a valve. The inlet flow (air, N_2 , or N_2/O_2) is divided into two branches having the same flow rate: in one of them the hydrocarbon is vaporised at a controlled rate. The two branches converge to a four-way valve, through which it is possible to create a step in the concentration of the VOC just before the reactor. A Pt-based catalyst supported over a monolith (VOC Catalyst, by Engelhard) has been adopted. The temperature of the inlet flow is controlled, using a thermocouple as a measuring device; the reactor can be assumed adiabatic.

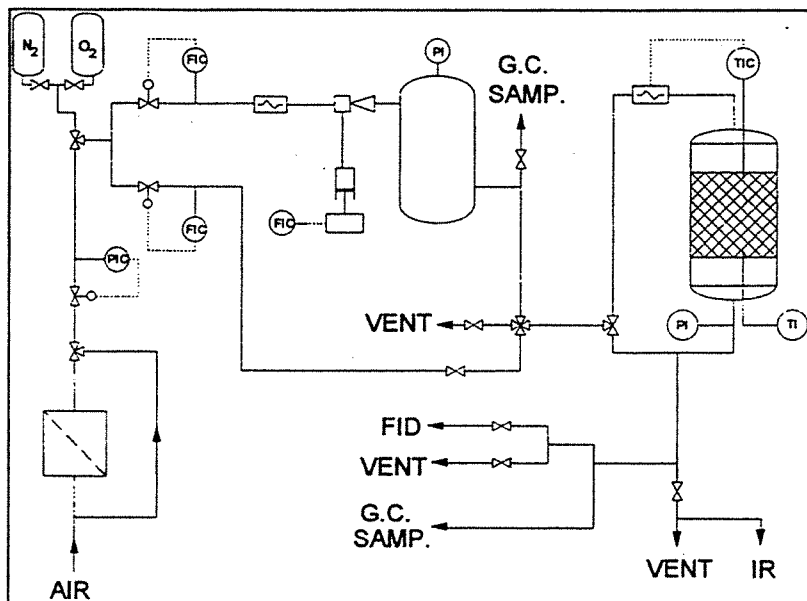

Figure 1. Experimental apparatus.

The VOCs investigated are toluene, ethylbenzene, xylene and styrene.

The reactor outlet is analysed on line using an infrared photometer (IR) and a flame ionisation detector (FID) for the measure of the concentration of CO_2 and hydrocarbon respectively. The outlet signal is sampled with a 4 Hz frequency and the data are stored using a PC; the transfer function of the photometer has been evaluated, and the measured CO_2 response has been deconvolved to obtain the real instantaneous value. A

gaschromatograph is used for the measurement of the steady-state concentration.

The different types of dynamic experiments performed are summarised in Table 1. The symbol " \Rightarrow " indicates the step change from the flow on the left to the one on the right. Both direct and reverse step were tested; the response to a reverse step resulted in more reliable results. Through these tests, it is possible to determine the sorption capacity of the catalyst in reactive and not reactive conditions, the irreversible component of the sorption, the importance of self-inhibition effects, and other interesting data.

Table 1 - Summary of dynamic experiments performed.

I	$N_2 + VOC \Leftrightarrow N_2$
II	$Air + VOC \Leftrightarrow Air$
III	$N_2 + VOC \Rightarrow N_2 \Rightarrow Air$
IV	$Air + VOC \Leftrightarrow N_2$
V	$N_2 + VOC \Leftrightarrow Air$

Results and discussion

Type I experiments allow to evaluate the amount of hydrocarbon that is adsorbed in non-reactive conditions. In Figure 2 the desorption curves observed after a stop in the hydrocarbon feed are shown. The curves are made dimensionless by dividing the outlet concentration by the

steady state concentration in the feed before the stop: in the range investigated (200 - 3000 ppm) the adsorption is linear with the gas phase concentration. The blank response, obtained with a non-adsorbable species (CO_2), is also shown; it differs from a perfect step due to dispersion effects in the line and non ideality of the inlet signal. In a reverse step experiment the quantity of hydrocarbon reversibly adsorbed can be evaluated from the area between the hydrocarbon response curve and the blank curve. The values are shown in Figure 3: the data have been divided by the inlet VOC concentration to take into account small variations in the initial concentration.

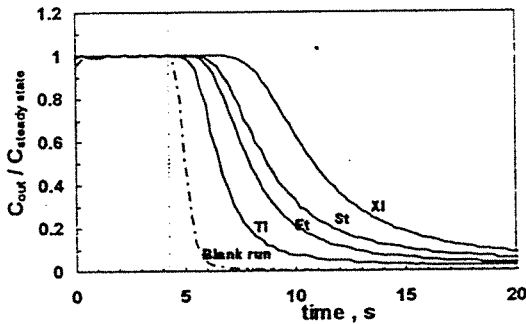

Figure 2. Dimensionless response curves for a stop in the VOC concentration; C_{ss} about 500 ppm (Tl = toluene, Et = ethylbenzene; St = styrene, XI = *o*-xylene). Detector FID.

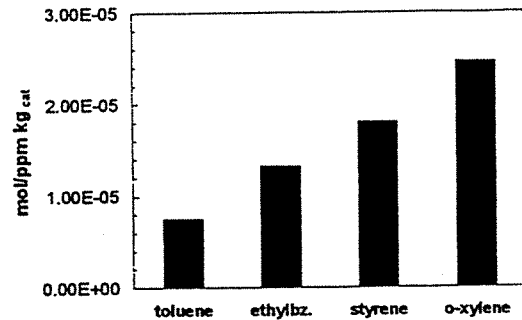

Figure 3. Comparison of the (reversible) sorption capacity for the tested VOCs.

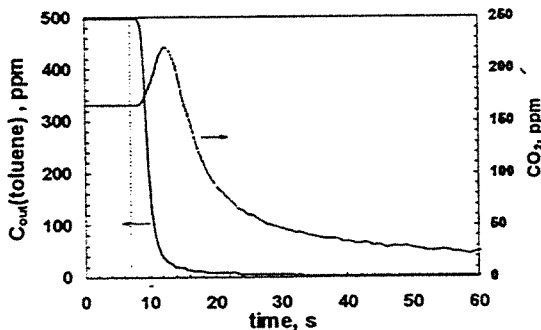

Figure 4. Comparison between the curve of desorption of the hydrocarbon and the curve of formation of CO_2 .

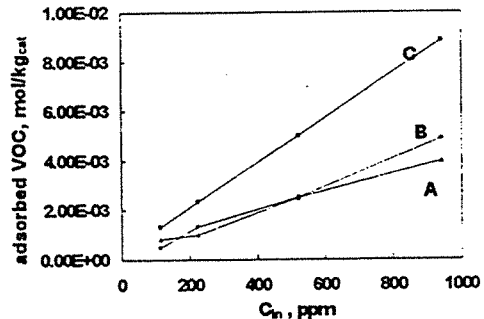

Figure 5. Adsorption of toluene in reactive conditions (II). A: adsorbed hydrocarbon that reacts; B: adsorbed hydrocarbon that desorbs; C: total adsorbed hydrocarbon.

The amount of VOC irreversibly adsorbed can be easily estimated with the type III experiments (introduction of air after the desorption of the VOC reversibly adsorbed is complete), by integrating the curve of CO_2 formation.

The tests in reactive conditions are similar, but it is necessary to record both the desorption of the VOC (FID) and the formation of CO_2 (IR) after the step. An example of the type II experiments is shown in Figure 4. The evolution of CO_2 indicates a strong self-inhibition effect. By this way it is possible to estimate the total amount of VOC adsorbed, as the sum of the amount that reacts and that desorbs: Figure 5 shows the values obtained for toluene. It is important to point out that the total amount evaluated in this way is equal to the sum of the amount reversibly adsorbed in non reactive condition and of that irreversibly adsorbed (evaluated from type I and type III experiments).

The direct measurement of the oxygen evolution would require the use of a mass spectrometer on-line; but with the type IV and V experiments it is possible to indirectly estimate the amount of oxygen adsorbed; the shape of the response curve can also give information on the competitive adsorption of VOC and oxygen. For the catalyst considered in this work the quantity of adsorbed O₂ is strongly lower than that of hydrocarbon; with type IV experiments the oxygen adsorbed (less the amount that desorbs before reaction) can be evaluated from the CO₂ evolution curve.

Conclusions

Our work proposes a simple and rapid method to evaluate the characteristics of commercial oxidation catalysts. Through dynamic experiments, that takes just few minutes each, there is the possibility to measure sorption capacities, strength and reversibility of bonds, possible self-inhibition effects. In this way, a sample of catalyst can be tested for many compounds in several different conditions, in a relatively short time. These data will be very useful to predict the performances of the catalyst in an unsteady-state reactor.

Acknowledgements - This work has been financially supported by the Italian National Research Council (C.N.R. - Progetto Strategico).

References

- Barresi A., Pommereul J., Pelissero M. and Baldi G., 1995, Catalytic combustion of aromatic solvents over Pt catalyst. Steady state and dynamic behaviour. *Abstracts Second Italian Conference on Chemical and Process Engineering, ICheaP-2 (AIDIC)*, Firenze, Italy, 15-17 May 1995, 324-328.
- Barresi A.A., Pommereul J., Pelissero M. and Baldi G., 1996, A transient kinetic study of VOC complete oxidation over a noble metal catalyst. *Odours&VOC's J.* 1, 407-413.
- Eigenberger G. and Nieken U., 1994, Catalytic cleaning of polluted air: reaction engineering problems and new solutions. *Int. Chem. Eng.* 34, 4-16.
- Matros Y.Sh., 1985, *Unsteady processes in catalytic reactors*. Elsevier, Amsterdam.
- Matros Y.Sh. and Bunimovich G.A., 1996, Reverse flow operation in fixed bed catalytic reactors. *Catal. Rev.-Sci. Eng.* 38, 1-68.

Finito di stampare nel mese di Aprile 1997
da La Elio Ticinese snc - Via Venosa, 4 - 20137 Milano